

VENDOR CONTRACT

Between _____ and
(Company Name)

THE INTERLOCAL PURCHASING SYSTEM (TIPS)
For
SECURITY/SURVEILLANCE SYSTEMS AND SERVICES
#06042315

General Information

The vendor contract shall include the contract, the terms and conditions, special terms and conditions, any agreed upon amendments, as well as all of the sections of the solicitation and the awarded vendor's proposal. Once signed, if an awarded vendor's proposal varies or is unclear in any way from the TIPS contract, TIPS, at its sole discretion, will decide which provision will prevail. Other documents to be included are the awarded vendor's proposals, task orders, purchase orders and any adjustments which have been issued.

The following pages will constitute the contract between the successful vendors(s) and TIPS. Bidders shall state, in a separate writing, and include with their proposal response, any required exceptions or deviations from these terms, conditions, and specifications. If agreed to by TIPS, they will be incorporated into the final contract.

The Vendor Contract ("Contract") made and entered into by and between The Interlocal Purchasing System (hereinafter referred to as "TIPS" respectfully) a government cooperative purchasing program authorized by the Region VIII Education Service Center, having its principal place of business at 4845 US Hwy 271 North, Pittsburg, Texas 75686. This contract consists of the provisions set forth below, including provisions of all Attachments referenced herein. In the event of a conflict between the provisions set forth below and those contained in any Attachment, the provisions set forth shall control.

Definitions

PURCHASE ORDER is the TIPS member's approval providing the authority to proceed with the negotiated delivery order under the contract. Special terms and conditions as agreed to between the vendor and TIPS member will be added as addendums to the PO. Items such as certificate of insurance, bonding requirements, small or disadvantaged business goals are some of the addendums possible.

PREMIUM HOURS are defined as those hours not included in regular hours or recognized holidays. Premium hours are to be approved by the TIPS member for each delivery order and noted in the delivery order proposal as a line item during negotiations.

REGULAR HOURS are defined as those hours between the hours of 7 AM and 6 PM Monday thru Friday.

Terms and Conditions

Freight

All deliveries shall be freight prepaid, F.O.B. destination and shall be included in all pricing offered unless otherwise clearly stated in writing.

Warranty Conditions

All supplies equipment and services shall include manufacturer's minimum standard warranty unless otherwise agreed to in writing. Vendor shall be an authorized dealer, distributor or manufacturer for all products. All equipment proposed shall be new unless clearly stated in writing.

Customer Support

The Vendor shall provide timely and accurate customer support to TIPS members. Vendors shall respond to such requests within one (1) working day after receipt of the request. Vendor shall provide training regarding products and services supplied by the Vendor unless otherwise clearly stated in writing at the time of purchase. (Unless training is a line item sold or packaged and must be purchased with product.)

Contracts

All contracts and agreements between Vendors and TIPS Members shall strictly adhere to the statutes that are set forth in the Uniform Commercial Code as most recently revised.

Contracts for purchase will normally be put into effect by means of a purchase order(s) executed by authorized agents of the participating government entities.

Davis Bacon Act requirements will be met when Federal Funds are used for construction and/or repair of buildings.

Tax exempt status

A taxable item sold, leased, rented to, stored, used, or consumed by any of the following governmental entities is exempted from the taxes imposed by this chapter:(1) the United States; (2) an unincorporated instrumentality of the United States; (3) a corporation that is an agency or instrumentality of the United States and is wholly owned by the United States or by another corporation wholly owned by the United States;(4) the State of Texas; (5) a Texas county, city, special district, or other political subdivision; or (6) a state, or a governmental unit of a state that borders Texas, but only to the extent that the other state or governmental unit

exempts or does not impose a tax on similar sales of items to this state or a political subdivision of this state. Texas Tax Code § 151.309.

Assignments of contracts

No assignment of contract may be made without the prior written approval of TIPS. Payment can only be made to the awarded Vendor or vendor assigned dealer.

Disclosures

1. Vendor affirms that he/she has not given, offered to give, nor intends to give at any time hereafter any economic opportunity, future employment, gift, loan, gratuity, special discount, trip, favor or service to a public servant in connection with this contract.
2. Vendor shall attach, in writing, a complete description of any and all relationships that might be considered a conflict of interest in doing business with participants in the TIPS program.
3. The vendor affirms that, to the best of his/her knowledge, the offer has been arrived at independently, and is submitted without collusion with anyone to obtain information or gain any favoritism that would in any way limit competition or give an unfair advantage over other vendors in the award of this contract.

Renewal of Contracts

The SECURITY/SURVEILLANCE SYSTEMS AND SERVICES contract is for one (1) year with an option for renewal for 2 consecutive years. Total term of contract can be up to 3 years if sales are reported through the contract and both parties agree.

Shipments

The Vendor shall ship ordered products within five (5) working days after the receipt of the order. If a product cannot be shipped within that time, the Vendor shall notify TIPS and the requesting entity as to why the product has not shipped and shall provide an estimated shipping date, if applicable. TIPS or the requesting entity may cancel the order if estimated shipping time is not acceptable.

Invoices

The Vendor or vendor assigned dealer shall submit invoices, to the TIPS participant. Each invoice shall include the TIPS participant's purchase order number. The shipment tracking number or pertinent information for verification of TIPS participant receipt shall be made available upon request. The Vendor or vendor assigned dealer shall not invoice for partial shipments unless agreed to in writing in advance by TIPS and the TIPS participant.

Payments

The TIPS participant will make payments directly to the Vendor or vendor assigned dealer at net 30 days after receiving invoice.

Pricing

The Vendor contracts to provide pricing to TIPS and its participating governmental entities that is the lowest pricing available to like cooperative purchasing customers and the pricing shall remain so throughout the duration of the contract.

The Vendor agrees to promptly lower the cost of any product purchased through TIPS following a reduction in the manufacturer or publisher's direct cost to the Vendor. Price increases will be honored. However, the Vendor shall honor previous prices for thirty (30) days after written notification to TIPS of an increase.

All pricing submitted to TIPS shall include the Two Percent (2%) participation fee to be remitted to TIPS by the Vendor. Vendor will not show adding the 2% to the invoice presented to customer.

Participation Fees

Vendor or vendor assigned dealer contracts to pay 2% of all sales to TIPS on a monthly scheduled report. TIPS will email a Monthly Submission Report to each vendor. The Vendor or vendor assigned dealer is responsible for keeping record of all sales that go through the TIPS contract. Report may be sent to TIPS electronically while check for 2% is mailed. Failure to pay 2% participation fee will result in termination of contract.

Indemnity

- 1. Indemnity for Personality Contracts.** Vendor agrees to indemnify and hold harmless and defend TIPS, TIPS member(s), officers and employees, from and against all claims and suits for damages, injuries to persons (including death), property damages, losses, and expenses including court costs and attorney's fees, arising out of, or resulting from, Vendor's performance of this contract, including all such causes of action based upon common, constitutional, or statutory law, or based in whole or in part, upon allegations of negligent or intentional acts on the part of the Vendor, its officers, employees, agents, subcontractors, licensees, invitees, whether or not such claims are based in whole or in part upon the negligent acts or omissions of the TIPS, TIPS member(s), officers, employees, or agents.
- 2. Indemnity for Performance Contracts.** The Vendor agrees to indemnify and hold harmless and defend TIPS, TIPS member(s), officers and employees from and against all claims and suits for damages, injuries to persons (including death), property damages, losses, and expenses including court costs and attorney's fees, arising out of, or resulting from, Vendor's work under this contract, including all such causes of action based upon common, constitutional, or statutory law, or based in whole or in part, upon allegations

of negligent or intentional acts on the part of the Vendor, its officers, employees, agents, subcontractors, licensees, or invitees. Vendor further agrees to indemnify and hold harmless and defend TIPS, TIPS member(s), officers and employees, from and against all claims and suits for injuries (including death) to an officer, employee, agent, subcontractor, supplier or equipment lessee of the Vendor, arising out of, or resulting from, Vendor's work under this contract whether or not such claims are based in whole or in part upon the negligent acts or omissions of the TIPS, TIPS member(s), officers, employees, or agents.

Attorney's Fees--Texas Local Government Code § 271.159 is expressly referenced.

Pursuant to §271.159, TEXAS LOC. GOV'T CODE, in the event that any one of the Parties is required to obtain the services of an attorney to enforce this Agreement, the prevailing party, in addition to other remedies available, shall be entitled to recover reasonable attorney's fees and costs of court.

Multiple Vendor Awards

TIPS reserves the right to award multiple vendor contracts for categories when deemed in the best interest of the TIPS membership. Bidders scoring 80% or above will be considered for an award. Categories are established at the discretion of TIPS.

State of Texas Franchise Tax

By signature hereon, the bidder hereby certifies that he/she is not currently delinquent in the payment of any franchise taxes owed the State of Texas under Chapter 171, Tax Code.

Miscellaneous

The Vendor acknowledges and agrees that continued participation in TIPS is subject to TIPS sole discretion and that any Vendor may be removed from the participation in the Program at any time with or without cause. Nothing in the contract or in any other communication between TIPS and the Vendor may be construed as a guarantee that TIPS participants will submit any orders at any time. TIPS reserves the right to request additional proposals for items already on contract at any time.

Purchase Order Pricing/Product Deviation

If a deviation of pricing/product on a purchase order occurs, TIPS is to be notified within 24 hours of receipt of order.

Cancellation for non-performance or contract deficiency

TIPS may terminate any contract if TIPS Members have not used the contract, or if purchase volume is determined to be "low volume" in any 12-month period. TIPS reserves the right to cancel the whole or any part of this contract due to failure by awarded vendor to carry out any

obligation, term or condition of the contract. TIPS may issue a written deficiency notice to awarded vendor for acting or failing to act in any of the following:

- Providing material that does not meet the specifications of the contract;
- Providing work and/or material that was not awarded under the contract;
- Failing to adequately perform the services set forth in the scope of work and specifications;
- Failing to complete required work or furnish required materials within a reasonable amount of time;
- Failing to make progress in performance of the contract and/or giving TIPS reason to believe that awarded vendor will not or cannot perform the requirements of the contract; and/or
- Performing work or providing services under the contract prior to receiving a TIPS reviewed purchase order for such work.

Upon receipt of the written deficiency, awarded vendor shall have ten (10) days to provide a satisfactory response to TIPS. Failure to adequately address all issues of concern may result in contract cancellation. Upon cancellation under this paragraph, all goods, materials, work, documents, data and reports prepared by awarded vendor under this contract shall become the property of the TIPS Member on demand.

TIPS Member Purchasing Procedures

Purchase orders are issued by participating TIPS member to the awarded vendor indicating on the PO "Contract Number 06042315". Purchase Order is emailed to TIPS at tipspo@tips-usa.com.

- Awarded vendor delivers goods/services directly to the participating member.
- Awarded vendor invoices the participating TIPS member directly.
- Awarded vendor receives payment directly from the participating member.
- Awarded vendor reports sales monthly to TIPS (unless prior arrangements have been made with TIPS to report monthly).

Form of Contract

The form of contract for this solicitation shall be the Request for Proposal, the awarded proposal(s) and best and final offer(s), and properly issued and reviewed purchase orders referencing the requirements of the Request for Proposals. If a vendor submitting an offer requires TIPS and/or TIPS Member to sign an additional agreement, a copy of the proposed agreement must be included with the proposal.

Vendor contract documents: TIPS will review proposed vendor contract documents. Vendor's contract document shall not become part of TIPS's contract with vendor unless and until an authorized representative of TIPS reviews and approves it.

Licenses

Awarded vendor shall maintain in current status all federal, state and local licenses, bonds and permits required for the operation of the business conducted by awarded vendor. Awarded vendor shall remain fully informed of and in compliance with all ordinances and regulations pertaining to the lawful provision of services under the contract. TIPS reserves the right to stop work and/or cancel contract of any awarded vendor whose license(s) expire, lapse, are suspended or terminated.

Novation

If awarded vendor sells or transfers all assets or the entire portion of the assets used to perform this contract, a successor in interest must guarantee to perform all obligations under this contract. TIPS reserves the right to accept or reject any new party. A simple change of name agreement will not change the contractual obligations of awarded vendor.

Site Requirements (when applicable to service or job)

Cleanup: Awarded vendor shall clean up and remove all debris and rubbish resulting from their work as required or directed by TIPS Member. Upon completion of work, the premises shall be left in good repair and an orderly, neat, clean and unobstructed condition.

Preparation: Awarded vendor shall not begin a project for which TIPS Member has not prepared the site, unless awarded vendor does the preparation work at no cost, or until TIPS Member includes the cost of site preparation in a purchase order.

Site preparation includes, but is not limited to: moving furniture, installing wiring for networks or power, and similar pre-installation requirements.

Registered sex offender restrictions: For work to be performed at schools, awarded vendor agrees that no employee of a sub-contractor who has been adjudicated to be a registered sex offender will perform work at any time when students are or reasonably expected to be present. Awarded vendor agrees that a violation of this condition shall be considered a material breach and may result in the cancellation of the purchase order at the TIPS Member's discretion.

Awarded vendor must identify any additional costs associated with compliance of this term. If no costs are specified, compliance with this term will be provided at no additional charge.

Safety measures: Awarded vendor shall take all reasonable precautions for the safety of employees on the worksite, and shall erect and properly maintain all necessary safeguards for protection of workers and the public. Awarded vendor shall post warning signs against all hazards created by the operation and work in progress. Proper precautions shall be taken pursuant to state law and standard practices to protect workers, general public and existing structures from injury or damage.

Smoking

Persons working under contract shall adhere to local smoking policies. Smoking will only be permitted in posted areas or off premises.

Invoices

The awarded vendor shall submit invoices to the participating entity clearly stating “Per TIPS Contract”. The shipment tracking number or pertinent information for verification shall be made available upon request.

Marketing

Awarded vendor agrees to allow TIPS to use their name and logo within website, marketing materials and advertisement. Any use of TIPS name and logo or any form of publicity, inclusive of press release, regarding this contract by awarded vendor must have prior approval from TIPS.

Supplemental agreements

The entity participating in the TIPS contract and awarded vendor may enter into a separate supplemental agreement to further define the level of service requirements over and above the minimum defined in this contract i.e. invoice requirements, ordering requirements, specialized delivery, etc. Any supplemental agreement developed as a result of this contract is exclusively between the participating entity and awarded vendor. TIPS, its agents, TIPS members and employees shall not be made party to any claim for breach of such agreement.

Legal obligations

It is the responding vendor’s responsibility to be aware of and comply with all local, state and federal laws governing the sale of products/services identified in this RFP and any awarded contract thereof. Applicable laws and regulations must be followed even if not specifically identified herein.

Audit rights

Awarded Vendor shall, at their sole expense, maintain appropriate due diligence of all purchases made by TIPS Member that utilizes this Contract. TIPS and Region 8 ESC each reserve the right to audit the accounting for a period of three (3) years from the time such purchases are made. This audit right shall survive termination of this Agreement for a period of one (1) year from the effective date of termination. TIPS shall have authority to conduct random audits of Awarded Vendor’s pricing that is offered to TIPS Members. Notwithstanding the foregoing, in the event that TIPS is made aware of any pricing being offered to eligible entities that is materially inconsistent with the pricing under this agreement, TIPS shall have the ability to conduct the audit internally or may engage a third-party auditing firm. In the event of an audit, the requested materials shall be provided in the format and at the location designated by Region 8 ESC or TIPS.

Force Majeure

If by reason of Force Majeure, either party hereto shall be rendered unable wholly or in part to carry out its obligations under this Agreement then such party shall give notice and fully particulars of Force Majeure in writing to the other party within a reasonable time after

occurrence of the event or cause relied upon, and the obligation of the party giving such notice, so far as it is affected by such Force Majeure, shall be suspended during the continuance of the inability then claimed, except as hereinafter provided, but for no longer period, and such party shall endeavor to remove or overcome such inability with all reasonable dispatch.

Services

When applicable, performance bonds will be required on construction or labor required jobs over \$100,000 and payment bonds on jobs over \$25,000 or awarded vendor will meet the TIPS member's local and state purchasing requirements. Awarded vendors may need to provide additional capacity as jobs increase. Bonds will not require that a fee be paid to TIPS. The actual cost of the bond will be a pass through to the TIPS member and added to the purchase order.

Scope of Services

The specific scope of work for each job shall be determined in advance and in writing between TIPS Member and Awarded vendor. It is okay if the TIPS member provides a general scope, but the awarded vendor should provide a written scope of work to the TIPS member as part of the proposal. Once the scope of the job is agreed to, the TIPS member will issue a PO with the estimate referenced as an attachment along with bond and any other special provisions agreed to for the TIPS member. If special terms and conditions other than those covered within this solicitation and awarded contracts are required, they will be attached to the PO and shall take precedence over those in the base contract.

Project Delivery Order Procedures

The TIPS member having approved and signed an interlocal agreement, or other TIPS membership document, may make a request of the awarded vendor under this contract when the TIPS member has services that need to be undertaken. Notification may occur via phone, the web, email, fax, or in person.

Upon notification of a pending request, the awarded vendor shall make contact with the TIPS member as soon as possible, but must make contact with the TIPS member within two working days.

Scheduling of Projects

Scheduling of projects (if applicable) will be accomplished when the TIPS member issues a purchase order that will serve as "the notice to proceed". The period for the delivery order will include the mobilization, materials purchase, installation and delivery, design, weather, and site cleanup and inspection. No additional claims may be made for delays as a result of these items. When the tasks have been completed the awarded vendor shall notify the client and have the TIPS member inspect the work for acceptance under the scope and terms in the PO. The TIPS member will issue in writing any corrective actions that are required. Upon completion of these items, the TIPS member will issue a completion notice and final payment will be issued.

Support Requirements

If there is a dispute between the awarded vendor and TIPS member, TIPS or its representatives will assist in conflict resolution or third party (mandatory mediation), if requested by either party. TIPS, or its representatives, reserves the right to inspect any project and audit the awarded vendors TIPS project files, documentation and correspondence.

Special Terms and Conditions

It is the intent of TIPS to contract with a reliable, high performance vendor to supply products and services to government and educational agencies. It is the experience of TIPS that the following procedures provide TIPS, the Vendor, and the participating agency the necessary support to facilitate a mutually beneficial relationship. The specific procedures will be negotiated with the successful vendor.

- **Contracts:** All vendor purchase orders must be emailed to TIPS at tipspo@tips-usa.com. Should an agency send an order direct to vendor, it is the vendor's responsibility to forward the order to TIPS at the email above within 24 business hours and confirm its receipt with TIPS.
 - **Promotion of Contract:** It is agreed that Vendor will encourage all eligible entities to purchase from the TIPS Program. Encouraging entities to purchase directly from the Vendor and not through TIPS contract is not acceptable to the terms and conditions of this contract and will result in removal of Vendor from Program. Vendor is expected to use marketing funds for the marketing and promotion of this contract.
 - **Daily Order Confirmation:** All contract purchase orders will be approved daily by TIPS and sent to vendor. The vendor must confirm receipt of orders to the TIPS member (customer) within 24 business hours.
 - **Vendor custom website for TIPS:** If Vendor is hosting a custom TIPS website, then updated pricing must be posted by 1st of each month.
 - **Back Ordered Products:** If product is not expected to ship within 3 business days, customer is to be notified within 24 hours and appropriate action taken based on customer request.
-

Check one of the following responses to the General Terms and Special Terms and Conditions:

() We take no exceptions/deviations to the general and/or special terms and conditions.

(Note: If none are listed below, it is understood that no exceptions/deviations are taken.)

() We take the following exceptions/deviations to the general and/or special terms and conditions. All exceptions/deviations must be clearly explained. Reference the corresponding general or special terms and conditions that you are taking exceptions/deviations to. The proposer must clearly state if you are adding additional terms and conditions to the general or special terms and conditions. Provide details on your exceptions/deviations below:

The Interlocal Purchasing System (TIPS Cooperative) Supplier Response

Bid Information		Contact Information		Ship to Information
Bid Creator	Mr. David Mabe National Coordinator	Address	Region VIII Education Service Center 4845 US Highway 271 North Pittsburg, TX 75686	Address
Email	david.mabe@tips-usa.com	Contact	Mrs. Kim Thompson Coordinator of Office Operations	Contact
Phone	+1 (903) 243-4759	Department		Department
Fax	+1 (866) 749-6674	Building		Building
Bid Number	06042315	Floor/Room		Floor/Room
Title	Security/Surveillance Systems and Services	Telephone	+1 (866) 839-8477	Telephone
Bid Type	RFP	Fax	+1 (866) 929-4402	Fax
Issue Date	02/02/2015	Email	bids@tips-usa.com	Email
Close Date	3/12/2015 3:00:00 PM CT			
Need by Date				

Supplier Information

Company Video Insight, Inc.
 Address 3 Riverway, Ste 700
 Houston, TX 77056

Contact
 Department
 Building
 Floor/Room

Telephone 1 (713) 6219779
 Fax 1 (713) 6217281
 Email

Submitted 2/27/2015 4:23:25 PM CT
 Total \$0.00

Signature Robert Shaw

Email olegt@video-insight.com

Supplier Notes

Bid Notes

Bid Activities

Bid Messages

Date	Subject	Message
02/02/15	PDF Files	<p>All PDF files are Fillable PDF Forms. You have to download the file to your computer, fill out the form, save the form, and upload the form to the "response attachments" section.</p> <p>If a signature is required you have to fill out the form, print the form, sign the form, scan the form, and upload the form to the "response attachments" section.</p>

Please review the following and respond where necessary

#	Name	Note	Response
1	Yes - No	Disadvantaged/Minority/Women Business Enterprise - D/M/WBE (Required by some participating governmental entities) Vendor certifies that their firm is a D/M/WBE? Vendor must upload proof of certification to the "Response Attachments" D/M/WBE CERTIFICATES section.	No
2	Yes - No	Highly Underutilized Business - HUB (Required by some participating governmental entities) Vendor certifies that their firm is a HUB? Vendor must upload proof of certification to the "Response Attachments" HUB CERTIFICATES section.	No
3	Yes - No	Certification of Residency (Required by the State of Texas) Company submitting bid is a Texas resident bidder?	Yes
4	Company Residence (City)	Vendor's principal place of business is in the city of?	Houston
5	Company Residence (State)	Vendor's principal place of business is in the state of?	Texas
6	Felony Conviction Notice:	(Required by the State of Texas) My firm is, as outlined on PAGE 5 in the Instructions to Bidders document: (Questions 7 - 9)	(No Response Required)
7	Yes - No	A publicly held corporation; therefore, this reporting requirement is not applicable?	No
8	Yes - No	Is not owned or operated by anyone who has been convicted of a felony?	Yes
9	Yes - No	Is owned or operated by individual(s) who has/have been convicted of a felony? If answer is YES, a detailed explanation of the name(s) and conviction(s) must be uploaded to the "Response Attachments" FELONY CONVICTION section.	No
10	Pricing Information:	Pricing information section. (Questions 11 - 14)	(No Response Required)
11	Yes - No	In addition to the typical unit pricing furnished herein, the Vendor agrees to furnish all current and future products at prices that are proportionate to Dealer Pricing. If answer is NO, include a statement detailing how pricing for TIPS participants would be calculated in the PRICING document that is uploaded to the "Response Attachments" PRICING section.	Yes
12	Yes - No	Pricing submitted includes the 2% TIPS participation fee?	No
13	Yes - No	Vendor agrees to remit to TIPS the required 2% participation fee?	Yes
14	Yes - No	Additional discounts to TIPS members for bulk quantities or scope of work?	No

15	Start Time	Average start time after receipt of customer order is ____ working days?	1
16	Years Experience	Company years experience in this category?	13
17	Yes - No	The Vendor can provide services and/or products to all 50 US States?	Yes
18	States Served:	If answer is NO to question #17, please list which states can be served. (Example: AR, OK, TX)	
19	Company and/or Product Description:	This information will appear on the TIPS website in the company profile section, if awarded a TIPS contract. (Limit 750 characters.)	Video Insight is a premiere provider of video surveillance software to 25,000 schools, universities, hospitals, government facilities and businesses across the nation. Video Insight offers an intelligent, user friendly, and state-of-the-art IP video surveillance solution that supports 2,200 camera models from 100 manufacturers.
20	Resellers:	Does the vendor have resellers that it will name under this contract? (If applicable, vendor should download the Reseller/Dealers spreadsheet from the Attachments section, fill out the form and submit the document in the "Response Attachments" RESELLERS section.	No
21	Primary Contact Name	Primary Contact Name	Linda Richardson
22	Primary Contact Title	Primary Contact Title	Director
23	Primary Contact Email	Primary Contact Email	lrichardson@video-insight.com
24	Primary Contact Phone	Primary Contact Phone - Format (xxx) xxx-xxxx	(713) 621-9779
25	Primary Contact Fax	Primary Contact Fax - Format (xxx) xxx-xxxx	(713) 621-7281
26	Primary Contact Mobile	Primary Contact Mobile- Format (xxx) xxx-xxxx	
27	Secondary Contact Name	Secondary Contact Name	Oleg Tsubulskiy
28	Secondary Contact Title	Secondary Contact Title	Operations
29	Secondary Contact Email	Secondary Contact Email	olegt@video-insight.com
30	Secondary Contact Phone	Secondary Contact Phone - Format (xxx) xxx-xxxx	(713) 621-9779
31	Secondary Contact Fax	Secondary Contact Fax - Format (xxx) xxx-xxxx	(713) 621-7281
32	Secondary Contact Mobile	Secondary Contact Mobile - Format (xxx) xxx-xxxx	
33	2% Contact Name	2% Contact Name	Linda Richardson
34	2% Contact Email	2% Contact Email	lrichardson@video-insight.com
35	2% Contact Phone	2% Contact Phone - Format (xxx) xxx-xxxx	(713) 621-9779
36	Purchase Order Contact:	This person is responsible for receiving Purchase Orders from TIPS. (Questions 37 - 39)	(No Response Required)
37	Purchase Order Contact Name	Purchase Order Contact Name	Ali Haroon
38	Purchase Order Contact Email	Purchase Order Contact Email	aharoon@video-insight.com
39	Purchase Order Contact Phone	Purchase Order Contact Phone - Format (xxx) xxx-xxxx	(713) 621-9779

40	Company Website	Company Website	www.video-insight.com
41	Federal ID Number:	Federal ID Number also known as the Employer Identification Number.	
42	Primary Address	Primary Address	3 Riverway Ste 700
43	Primary Address City	Primary Address City	Houston
44	Primary Address State	Primary Address State	Texas
45	Primary Address Zip	Primary Address Zip	77056
46	Search Words:	Please list search words to be posted in the TIPS database about your company that TIPS website users might search. Words may be product names, manufacturers, or other words associated with the category of award. YOU MAY NOT LIST NON-CATEGORY ITEMS. (Limit 500 words) (Format: product, paper, construction, manufacturer name, etc.)	video surveillance, IP camera, IP video, security camera, surveillance system, security system, access control, security surveillance, surveillance equipment, video system
47	Yes - No	Do you wish to be eligible to participate in a TIPS contract in which a TIPS member utilizes federal funds on contracts exceeding \$100,000? (Non-Construction) (If YES, vendor should download the Federal Funds Over \$100,000 Certification document from the Attachments section, fill out the form and submit the document in the "Response Attachments" FEDERAL FUNDS section.) (Vendor must also download the Suspension or Debarment Certificate document from the Attachments section, fill out the form and submit the document in the "Response Attachments" SUSPENSION OR DEBARMENT section.)	Yes

Line Items

Response Total: \$0.00

Provisions for purchase with federal funds for contracts exceeding \$100,000
These forms are for non-construction contracts

Many TIPS members (grantees and sub-grantees) purchase goods and services with federal funds. When a member engages a contract exceeding \$100,000 and paid with federal funds, provisions are triggered by various Code of Federal Regulations requirements. Primarily 34 CFR 80.36 from the Department of Education and 7 CFR 3015 & 3016 from the Department of Agriculture for School Lunch Program. There may be other Federal programs from time to time that are not enumerated above that may fund certain projects using outside vendors. These are not optional for the contracting entity and in order to spend the federal funds certain provision and certifications must be in place to ensure legal compliance.

If your company wishes to be eligible to participate in a TIPS contract in which a member utilizes federal funds on contracts exceeding \$100,000, you must complete the following forms can provide the certifications as required on the subsequent pages.

Do you wish to be eligible to participate in a TIPS contract in which a member utilizes federal funds on contracts exceeding \$100,000?

Check your response?

YES NO



2/23/2015

Signature of Authorized Company Official

Date

Robert Shaw

Printed Name of Authorized Company Official

Video Insight, inc.

Company Name

Attach to this page a current W-9 form

Please complete the forms below

Legal Compliance

It is the proposing company's duty and responsibility to have knowledge of and be responsible for the compliance with all applicable laws, rules and regulations as they apply to this procurement process and any subsequent award. The vendor agrees to comply, in all relevant respects, with all Federal, State, and Local laws, rules and regulations related to the performance of services or supply of goods to TIPS or TIPS members?

Does vendor agree? YES ^{RS} _____ Initial of Authorized Company Official

Non-Collusive Bidding Certificate

By submitting a proposal in response to a Request for Proposals or other procurement device containing this clause, you certify that you are authorized to certify to the following:

- 1) This bid or proposal has been independently arrived at without collusion with any other Bidder or with any Competitor;
- 2) This bid or proposal has not been knowingly disclosed and will not be knowingly disclosed, prior to the opening of bids, or proposals for this project, to any other Bidder, Competitor or potential competitor;
- 3) No attempt has been or will be made to induce any other person, partnership or corporation to submit or not to submit a bid or proposal;
- 4) The person signing this bid or proposal certifies that he has fully informed himself regarding the accuracy of the statements contained in this certification, and under the penalties being applicable to the Bidder as well as to the person signing in its behalf.

The vendor complied with #1 through 4 above? YES ^{RS} _____ Initial of Authorized Company Official

SUSPENSION OR DEBARMENT CERTIFICATE

Non-Federal entities are prohibited from contracting with or making sub-awards under covered transactions to parties that are suspended or debarred or whose principals are suspended or debarred. Covered transactions include procurement for goods or services equal to or in excess of \$100,000.00. Contractors receiving individual awards for \$25,000.00 or more and all sub-recipients must certify that the organization and its principals are not suspended or debarred.

You certify that no suspension or disbarment is in place, which would preclude receiving a federally funded contract under the Federal OMB, A-102, common rules

The vendor has not been debarred? YES ^{RS} _____ Initial of Authorized Company Official

Certification Regarding Lobbying

**Applicable to Grants, Subgrants, Cooperative Agreements, and Contracts Exceeding
\$100,000 in Federal Funds**

Submission of this certification is a prerequisite for making or entering into this transaction and is imposed by section 1352, Title 31, U.S. Code. This certification is a material representation of fact upon which reliance was placed when this transaction was made or entered into. Any person who fails to file the required certification shall be subject to a civil penalty of not less than

\$10,000 and not more than \$100,000 for each such failure.

The undersigned certifies, to the best of his or her knowledge and belief, that:

(1) No Federal appropriated funds have been paid or will be paid by or on behalf of the undersigned, to any person for influencing or attempting to influence an officer or employee of any agency, a Member of Congress, an officer or employee of congress, or an employee of a Member of Congress in connection with the awarding of a Federal contract, the making of a Federal grant, the making of a Federal loan, the entering into a cooperative agreement, and the extension, continuation, renewal, amendment, or modification of a Federal contract, grant, loan, or cooperative agreement.

(2) If any funds other than Federal appropriated funds have been paid or will be paid to any person for influencing or attempting to influence an officer or employee of any agency, a Member of Congress, an officer or employee of congress, or an employee of a Member of Congress in connection with this Federal grant or cooperative agreement, the undersigned shall complete and submit Standard Form-LLL, "disclosure Form to Report Lobbing," in accordance with its instructions.

(3) The undersigned shall require that the language of this certification be included in the award documents for all covered subawards exceeding \$100,000 in Federal funds at all appropriate tiers and that all subrecipients shall certify and disclose accordingly.

Video Insight, Inc.

Name of Organization

3 Riverway Ste 700 Houston, TX 77056

Address of Organization

Robert Shaw / COO

Name / Title of Submitting Official

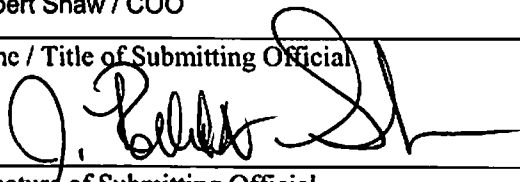

Signature of Submitting Official

2-23-2015

Signature Date

Provisions for purchase with federal funds for contracts exceeding \$100,000

Federal Rule (1) Administrative, contractual, or legal remedies in instances where contractors violate or breach contract terms, and provide for such sanctions and penalties as may be appropriate. (Contracts more than the simplified acquisition threshold)

Notice: Pursuant to Federal Rule (1) above, when federal funds are expended by TIPS Member, TIPS Member reserves all rights and privileges under the applicable laws and regulations with respect to this procurement in the event of breach of contract by either party.

Does vendor agree? YES ^{RS} _____ Initial of Authorized Company Official

Federal Rule (2) Termination for cause and for convenience by the grantee or subgrantee including the manner by which it will be effected and the basis for settlement. (All contracts in excess of \$10,000)

Pursuant to Federal Rule (2) above, when federal funds are expended by TIPS Member, TIPS Member reserves the right to terminate any agreement in excess of \$10,000 resulting from this procurement process for cause after giving the vendor an appropriate opportunity and up to 30 days, to cure the causal breach of terms and conditions. TIPS Member reserves the right to terminate any agreement in excess of \$10,000 resulting from this procurement process for convenience with 30 days notice in writing to the awarded vendor. Any award under this procurement process is not exclusive and the District reserves the right to purchase goods and services from other vendors when it is in the best interest of the District.

Does vendor agree? YES ^{RF} _____ Initial of Authorized Company Official

Federal Rule (7) Notice of awarding agency requirements and regulations pertaining to reporting.

Pursuant to Federal Rule (7) above, when federal funds are expended by TIPS Member, TIPS Member requires that the proposer certify that during the term of an award by the TIPS Member resulting from this procurement process the vendor will provide reports and documentation required by all applicable law and state and federal regulations upon request by the TIPS Member or any relevant state of federal agency.

Does vendor agree? YES ^{RS} _____ Initial of Authorized Company Official

Federal Rule (8) Notice of awarding agency requirements and regulations pertaining to patent rights with respect to any discovery or invention which arises or is developed in the course of or under such contract.

Provisions for purchase with federal funds for contracts exceeding \$100,000

Pursuant to Federal Rule (8) above, when federal funds are expended by TIPS Member, TIPS Member shall address any requirements and regulations pertaining to patent rights with respect to any discovery or invention which arises or is developed in the course of or under such contract in the contract document and absent language to the contrary or if the contract silent on the subject, the District retains all rights thereto.

Does vendor agree? YES ^{RS} _____ Initial of Authorized Company Official

Federal Rule (9) Awarding agency requirements and regulations pertaining to copyrights and rights in data.

Pursuant to Federal Rule (9) above, when federal funds are expended by TIPS Member, TIPS Member requires the proposer certify that during the term of an award by the TIPS Member resulting for this procurement process the vendor will surrender upon request any copyrighted materials owned by the TIPS Member but used in the awarded contract performance unless otherwise agreed in a written document by the parties. TIPS Member reserves the rights to all data created or provided to the vendor for the purpose of contract performance resulting for this procurement process and the vendor will surrender such data upon request unless otherwise agreed in a written document by the parties. If the contract is silent or not dispositive on the subject matter data or copyrights TIPS Member retains all rights in the data developed or gathered during the contract term.

Does vendor agree? YES ^{RS} _____ Initial of Authorized Company Official

Federal Rule (10) Access by the grantee, the subgrantee, the Federal grantor agency, the Comptroller General of the United States, or any of their duly authorized representatives to any books, documents, papers, and records of the contractor which are directly pertinent to that specific contract for the purpose of making audit, examination, excerpts, and transcriptions.

Pursuant to Federal Rule (9) above, when federal funds are expended by TIPS Member, TIPS Member requires the proposer certify that during the term and after the awarded term of an award by the TIPS Member resulting for this procurement process the vendor will grant access by the grantee, the subgrantee, the Federal grantor agency, the Comptroller General of the United States, or any of their duly authorized representatives to any books, documents, papers, and records of the contractor which are directly pertinent to that specific contract for the purpose of making audit, examination, excerpts, and transcriptions.

Does vendor agree? YES ^{RS} _____ Initial of Authorized Company Official

Provisions for purchase with federal funds for contracts exceeding \$100,000

Federal Rule (11) Retention of all required records for three years after grantees or subgrantees make final payments and all other pending matters are closed.

Pursuant to Federal Rule (11) above, when federal funds are expended by TIPS Member, TIPS Member requires the proposer certify that the awarded vendor retain of all required records for three years after grantees or subgrantees make final payments and all other pending matters are closed.

Does vendor agree? YES ^{RS} _____ Initial of Authorized Company Official

Federal Rule (12) Compliance with all applicable standards, orders, or requirements issued under section 306 of the Clean Air Act (42 U.S.C. 1857(h)), section 508 of the Clean Water Act (33 U.S.C. 1368), Executive Order 11738, and Environmental Protection Agency regulations (40 CFR part 15). (Contracts, subcontracts, and subgrants of amounts in excess of \$100,000)

Pursuant to Federal Rule (12) above, when federal funds are expended by TIPS Member, TIPS Member requires the proposer certify that in performance of the contracts, subcontracts, and subgrants of amounts in excess of \$100,000, the vendor will be in compliance with all applicable standards, orders, or requirements issued under section 306 of the Clean Air Act (42 U.S.C. 1857(h)), section 508 of the Clean Water Act (33 U.S.C. 1368), Executive Order 11738, and Environmental Protection Agency regulations (40 CFR part 15).

Does vendor agree? YES ^{RS} _____ Initial of Authorized Company Official

Federal Rule (13) Mandatory standards and policies relating to energy efficiency which are contained in the state energy conservation plan issued in compliance with the Energy Policy and Conservation Act (Pub. L. 94-163, 89 Stat. 871).

Pursuant to Federal Rule (13) above, when federal funds are expended by TIPS Member, TIPS Member requires proposer certify that during the term of an award by the TIPS Member resulting for this procurement process the vendor will be in compliance with mandatory standards and policies relating to energy efficiency which are contained in the state energy conservation plan issued in compliance with the Energy Policy and Conservation Act (Pub. L. 94-163, 89 Stat. 871).

Does vendor agree? YES ^{RS} _____ Initial of Authorized Company Official

SUSPENSION OR DEBARMENT CERTIFICATE

Non-Federal entities are prohibited from contracting with or making sub-awards under covered transactions to parties that are suspended or debarred or whose principals are suspended or debarred. Covered transactions include procurement for goods or services equal to or in excess of \$100,000.00. Contractors receiving individual awards for \$25,000.00 or more and all sub-recipients must certify that the organization and its principals are not suspended or debarred.

You certify that no suspension or disbarment is in place, which would preclude receiving a federally funded contract under the Federal OMB, A-102, common rules

Information may be found at <https://www.sam.gov/index.html>

Has the vendor been debarred form participation in Federal funds contracts?

NO ____ Initial of Authorized Company Official

YES ____ Initial of Authorized Company Official

Company Official: _____



Company: _____

CONTRACT Signature Form

The undersigned hereby proposes and agrees to furnish goods and/or services in compliance with the terms, specifications and conditions at the prices quoted unless noted in writing. The undersigned further certifies that he or she is an authorized agent of the company and has authority to negotiate and contract for the company named below.

Company Name: Video Insight, Inc.
Mailing Address: 3 Riverway Ste 700
City: Houston
State: TX
Zip: 77056
Telephone Number: (713) 621-9779
Fax Number: (713) 621-7281
Email Address: Irichardson@video-insight.com
Authorized Signature: 
Printed Name: Robert Shaw
Position: COO

This contract is for a total TERM of one year with the option of two additional years. Vendors shall honor the participation fee for any sales made based on the TIPS contract. Failure to pay the fee will be grounds for termination of contract and will affect the award of future contracts.

 4-23-15
TIPS Authorized Signature Date
 4-23-15
Approved by Region VIII ESC Date

References

**** Must have at least 3 References. References must be School, City, County, University, State Agency or Other Government.**

Organization	City	State	Contact Name	Contact Phone
Klein ISD	Klein	TX	Randall Davidson	832-249-4427
Temple ISD	Temple	TX	Vance Willis	254-721-2837
Austin ISD	Austin	TX	Wayne Berry	512-414-2215
Pasadena ISD	Pasadena	TX	Barrie Cudmore	713-740-0154
Pearland ISD	Pearland	TX	Gary Mcleod	281-484-3202
Judson ISD	Live Oak	TX	Steve Young	210-945-5562

VIDEOINSIGHT

Product and Services Warranty

Product Warranty

What Does This Warranty Cover?

Video Insight, Inc. (the “Company”) warrants to the Original Purchaser that the Company’s hardware is free from defects in workmanship or material under normal user and service. This warranty commences on the date of delivery of the hardware to the Original Purchaser.

What are the Company’s Obligations Under this Warranty?

During the warranty period, the Company agrees to repair or replace, at its sole option, without charge to Original Purchaser, any defective component part of the hardware. To obtain service, Original Purchaser must return the hardware to the Company in an adequate container for shipping. All defective products must be returned to the Company within thirty (30) days of failure. Products must be returned with a description of the failure and Return Merchandise Authorization (RMA) number supplied by the Company. To receive a RMA number and obtain assistance on where to deliver the hardware, call 713-621-9779. The postage, shipping, and insurance charges incurred in shipping to the Company will be paid by Original Purchaser, and all risk for the hardware shall remain with the Original Purchaser until such time as Company takes receipt of the hardware. Upon receipt, the Company will promptly repair or replace the defective unit, and then return said unit to Original Purchaser, postage and shipping prepaid. The Company may use reconditioned or like-new parts or units, at its sole option, when repairing any hardware. Repaired products shall carry the same amount of outstanding warranty as from original purchase, or ninety (90) days, whichever is greater. Any claim under the warranty must include dated proof of purchase or invoice. In any event, the Company’s liability for defective hardware is limited to repairing or replacing the hardware.

What Does This Warranty Not Cover?

This warranty is contingent upon proper use of the hardware by Original Purchaser and does not cover: if damage is due to accident; unusual physical, electrical, or electromechanical stress; modifications; neglect; misuse; failure of electric power, air conditioning, or humidity control; transportation; operation with media not approved by the Company; or tampering with or altering of the hardware.

What is the Length of the Warranty?

The warranties given herein, together with any implied warranties covering the hardware, including any warranties of merchantability or fitness for a particular purpose, are limited in duration to **three years** from the date of delivery to Original Purchaser. Jurisdictions vary with regard to the enforceability of warranty limitations, and you should check the provisions of your local jurisdiction to find out whether the above limitation applies to you.

Services Warranty

Video Insight, Inc. (the “Company”) warrants to the Original Purchaser that all labor services performed by the Company will be done in a professional manner and in accordance with industry standards. The service warranty commences on the date of service delivery to the Original Purchaser and will be in effect for one year.

What are the Limits of the Company’s Liability?

The Company shall not be liable to you for loss of data, loss of profits, lost savings, special, incidental, consequential, indirect or other similar damages arising from breach of warranty, breach of contract, negligence or other legal action even if the Company or its agent has been advised of the possibility of such damages, or for any claim brought against you by another party. Jurisdictions vary with regard to the enforceability of provisions excluding or limiting liability for incidental or consequential damages. You should check the provisions of your local jurisdiction to find out whether the above exclusion applies to you.

This warranty allocates risks of product failure between Original Purchaser and the Company. The Company’s hardware pricing reflects this allocation of risk and the limitations of liability contained in this warranty. The warranty set forth above is in lieu of all other express warranties, whether oral or written. The agents, employees, distributors, and dealers of the Company are not authorized to make modification to this warranty or additional warranties binding on the Company. Accordingly, additional statements such as dealer advertising or presentations, whether oral or written, do not constitute warranties by the Company and should not be relied upon.

This warranty gives you specific legal rights. You may also have other rights which vary from one jurisdiction to another.



Recorded

- Intuitive access to recorded video from any camera in system regardless of location
- Frame-by-Frame or variable playback speeds up to 16X
- View single camera or drag and drop up to 16 cameras for Synchronized Playback
- View groups of cameras via drag and drop
- Slider bar provides quick access to events
- Digital zoom on all recorded video
- Save JPEG or print snapshots
- Synchronized video and audio
- Instant replay of last 30 seconds of recorded video
- Create a clip with use of guides marking time interval
- Save clip to local client or server
- Continuous, motion activated, scheduled, event or trigger based recording
- Record up to 30 FPS or as little as 1 image per second, hour or day
- Record always at 1 FPS and higher frame rate on motion or alarm
- Pre- and Post-motion recording
- Support for camera and server side motion detection
- Create sensitivity zones in Windows client or camera configuration
- Motion Event logs provide quick review of video associated with motion or alarm events
- View recorded video from archived servers
- Graphical timeline highlights motion events
- Smart Search
- Progressive download speeds for slow-speed connection
- Automatically manages files and disk space
- Specify maximum retention by camera
- Panoramic/360 De-warped support
- View full aspect ratio of 16:9 or 4:3
- Predefined layouts stored in the database can pull cameras from multiple servers, restricted by security level
- Camera touring or Layout sequencing
- View full aspect ratio of 16:9 or 4:3
- 180° stitched layouts
- Single, Quad and Panorama views for 360 cameras
- Three PTZ control options including on-screen overlay commands, left navigation control and pop-up menu options
- Cycle PTZ presets, pausing for specified interval
- PTZ control with USB Joysticks
- Option to lock down non-admin users from PTZ controls
- PTZ Prioritization – Users can be ranked to determine who has PTZ operations at a specific time
- Search box allows quick access to any camera or server - search by partial name or IP address
- Save JPEG or print snapshots
- Push live video pop-up windows to other logged in users
- 2Way audio allows operators to interact with video
- Create Covert cameras by removing from navigation
- Pause individual camera for instant investigation
- High Performance option renders video in real time
- Run in Full Screen mode with limited menus
- Connect up to four monitors per PC
- Video Wall app supports up to 64 monitors
- Operators can push video to a Video Wall, cycle layouts or view alarms
- Motion alerts displayed for each camera
- Option to play sound on motion alarm
- Launch clients in full screen mode to predefined layouts
- Panoramic/360 De-warped support
- Public View App displays live images directly from camera without connecting to a server
- Lane Viewer App displays live images along with card holder picture and information to verify identity

Video Export

- Save JPEG or print snapshots
- Clips include visible watermark, server based date/time stamp and camera name
- Option to include MD5 checksum watermark in each clip, use Standalone Player to validate
- Recorded video is saved in cameras native or MJPEG compression in AVI file
- Exported clips include audio
- Synchronized video export of up to 9 video streams in single AVI file
- Standalone Player with Watermark Validation – Review recorded video on any PC while viewing thumbnails and using a scroll bar for precise investigation - includes option to validate a watermark

Live Video

- Full-featured Windows, Web, and Mobile Clients
- iPhone and iPad app available for free on iTunes
- Mobile App supports live and recorded video from any camera, control of PTZs and email images
- Web Client supports IE, Safari, FireFox, Opera and Chrome - Active X is optional
- Macintosh support via Web Client
- Support for other smartphone devices including Blackberry and Windows Phones
- Client applications require little or no end user training
- View live video from any camera across multiple servers
- Quickly navigate between cameras from any server using standard Windows Explorer tree structure
- Unlimited users can view live video
- Digital Zoom on any image with mouse click
- Picture-in-Picture of zoomed area
- Create customized layouts and layout groups
- Drag cameras from left navigation tree into layout

Facility Maps

- Multi-level mapping provides quick access to cameras
- Mouse over Camera icons for live video pop-up
- Zoom into maps or navigate between multiple layers
- Quick access to recorded video from facility maps
- Launch specified facility map on startup
- View maps from Windows or Web Clients
- Mouse over Layout icons to switch live displays to groups of cameras in the area
- Easy setup requires JPEG, BMP or GIF images and drag and drop camera placement of maps, cameras, layouts or doors

Notifications & Automation

- Pop-up live windows of alarmed cameras
- Red outline in camera layout on alarm conditions
- Play audio file on alarm to alert operator
- Pop-up window with detailed instructions for operator
- Alarm actions include changing displays, execute DIO commands, display instant replay, push image to video wall, cycle spot monitor, move PTZ to presets, change recording options and record with audio
- Email or send text message of JPEG or AVI clip
- Alerts can be directed to specific users or groups
- Powerful Rules Wizard allows easy configuration of an unlimited number of automation tasks that allow the system to take actions after an event
- Motion alerts displayed for each camera
- Option to play a sound on motion alarm
- Send JPEG snapshots on an interval or on motion

- Alter operators of camera side Analytic events
- Using Analytic Tripwire, count people entering and exiting facility to keep running total and alert if threshold exceeded

Enterprise Functionality

- Support for unlimited cameras and recording servers
- Distributed login to any server prevents single point of failure
- Support for both centralized and distributed architectures
- Use existing SQL Server infrastructures or included SQL Express
- Centralized Management – all camera configurations for all servers are done from one easy to use setup screen
- Authenticate users with a Video Insight users database or with integration of users and groups from Active Directory, LDAP or Novell eDirectory
- Assign individual camera permissions to users or groups
- All system and user settings are stored in SQL database
- Centralized storage of user layouts and centrally managed
- Automatic Failover
- Health Monitor – comprehensive monitoring and alerting of system status
- Audit Trail of all user logins and configuration changes stored in a SQL database
- Automatic upgrade of client applications
- Automatic system backup
- Complete system performance statistics including - Storage, Bandwidth, Resolution, Format and Frame Rate
- Users only see assigned cameras regardless of number of servers
- Export camera and server information in Excel format
- Camera Maintenance logging and tracking
- .Net-based Software Development Kit

Security

- Enterprise-wide user management
- Multi-level security including restriction of setup, management, live and recorded viewing, PTZ operation, access to layouts, facility maps, rules and clip creation
- Authenticate users with a Video Insight users database or with integration of users and groups from Active Directory, LDAP or Novell eDirectory
- Assign individual camera permissions to users or groups
- Comprehensive log of all changes to system
- Option to restrict users from logging in from multiple locations
- Limit users to a single login per username
- Option for inserting MD5 checksum into all recorded video files to detect any tampering

Camera Support

- Deep integration for *1,800 camera models from 80 manufacturers
*Complete list available at www.video-insight.com
- Universal camera driver provides support for almost all other cameras via ONVIF, RTSP or HTTP
- Advanced camera features from Axis, Panasonic, IQeye, Sony, Sentry 360, Scallop and Immervision
- Single, Quad and Panorama views for 360 cameras
- Resolutions up to 20 Megapixel
- MJPEG, MPEG4, H.264 Compressions
- Multicasting support
- Multistreaming
- Camera or server side motion detection
- Support sensitivity and privacy zones
- Camera auto discovery
- Centralized camera management
- Audio inputs and outputs
- Combine audio and video from two independent sources
- Send live video to Axis Decoders
- Trigger Digital Inputs and Outputs

Technology

- Pure 64-bit Server and Client
- Takes advantage of all available memory
- Optimized for centralization
- Robust scalable design
- Developed in open technologies including Microsoft .Net and SQL Server
- Virtualization support for VMware, Hyper-V and Xen Server
- Automated failover support
- Access live and recorded video or control the server with .NET SDK
- Easy integration with 3rd party application via the well defined SQL tables
- Server Software runs as a Windows Service
- Clients can connect to a single IP address to access the entire system
- Servers are connected to cameras and clients are connected to the servers - Clients do not connect directly to cameras
- Email support for SSL and alternate ports, supporting Gmail and Hotmail
- SSL certificates for secure web client transmissions
- Execute programs or batch files on triggered event

Storage

- Flexible high-speed storage design with no limits
- Support for internal and external storage devices including NAS, SAN and iSCSI
- Support for Pivot3 Cloudbank failover architecture and Dell EqualLogic iSCSI
- Integrator support for Veracity Coldstore
- Intransa Virtual and iSCSI solutions
- Long Term Storage for recorded video file management
- Move recorded video from single or multiple cameras or servers on a schedule basis
- Option to restrict users from logging in from multiple locations

Performance

- 250 two megapixel cameras per operating system
- Deep camera integration technology and storage architecture allow extreme server performance
- Total camera bandwidth of 600 Mbits/sec
- Unrestricted number of clients
- Load balancing
- High Performance live display mode can show up to 36 megapixel images at 30 FPS

Licensing

- Simple per camera licensing available in single camera increments
- No base or server fees
- Individual camera MAC address registration is not required
- No extra licensing costs for client applications
- Virtual cameras require only a single license
- Multi-stream connections only require one license
- Arecont 180° and 360° cameras require only a single license

Support Options

- Lifetime technical support Monday through Saturday
- Unlimited software updates
- Remote control applications for unattended access

Access Control Integration

- Lenel
- IMRON
- S2
- DSX
- RS2
- Blackboard
- Paxton
- AMAG
- HID

WebClient⁵

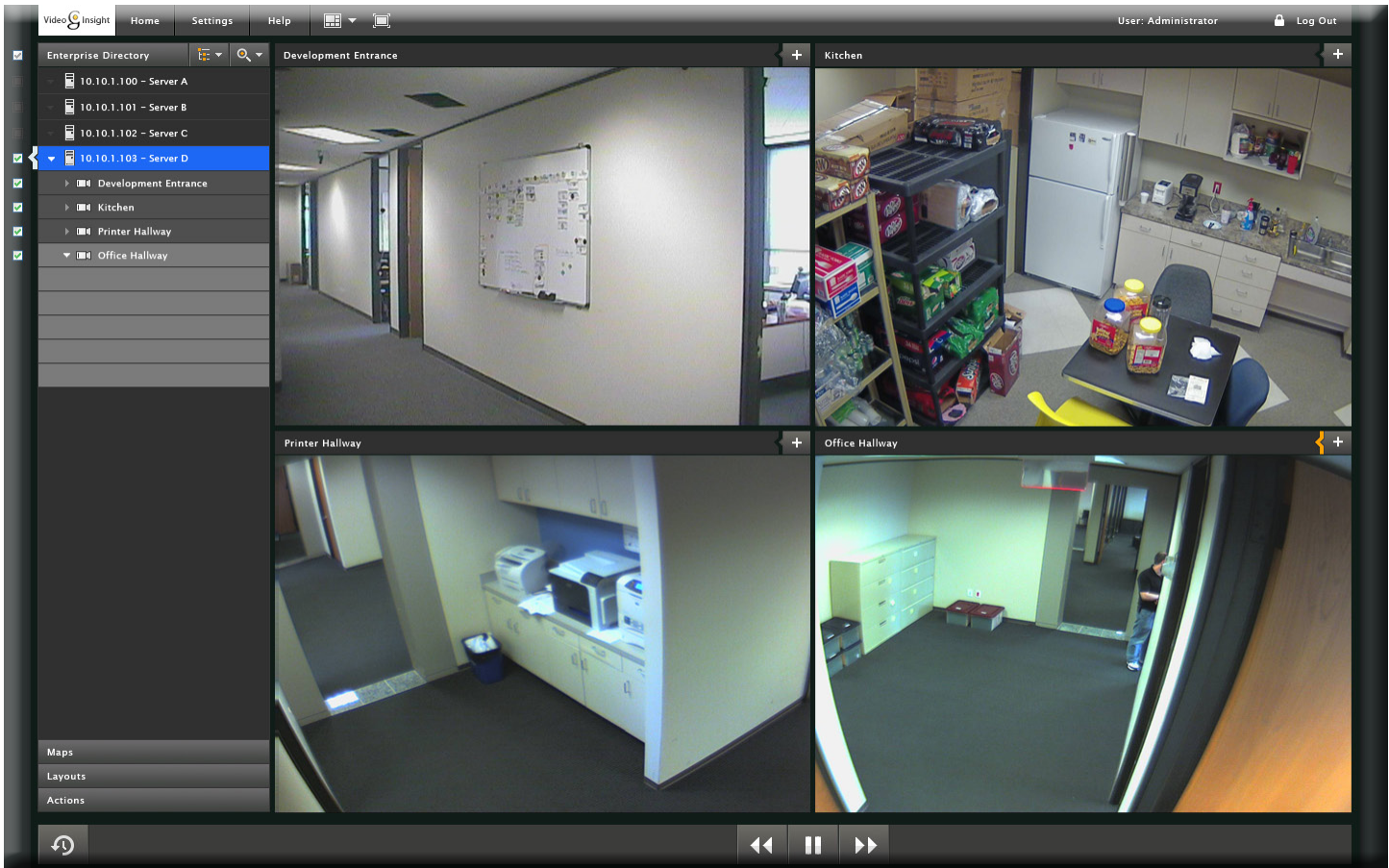

- Easy to use
- Live and recorded video from any server
- Playback integrated with Live control
- Optional ActiveX control
- Any browser
- AD and LDAP authentication
- No per-user licensing
- High performance
- Load balancing
- Quick search
- Maps

VIDEOINSIGHT
Enterprise Video Management Software



Centralize • Simplify • Reduce Cost
www.video-insight.com • 713.621.9779

PreLoaded Network Video Recorder - 1U Rack Server with 2 Drive Bays

- Easy Installation
- IP Licenses Activated
- Tested and Configured
- Superior US-based Technical Support
- 3 Year Hardware Limited Warranty*
- 5 years VMS Software Upgrades Included



Video Insight NVR's come pre-loaded, activated and tested with the full Video Insight Software Suite. The "plug and play" NVRs are ready immediately out of the box for a quick start to record and view your cameras.

MODEL SPECIFICATIONS

Model	Total Storage	RAM	Processor	Power Supply
NVR-R-1-1-1TB	1TB	4GB	Single	Single
NVR-R-1-1-2TB	2TB	4GB	Single	Single
NVR-R-1-1-3TB	3TB	4GB	Single	Single
NVR-R-1-1-4TB	4TB	4GB	Single	Single

SERVER SPECIFICATIONS

	Dell PowerEdge R210 Class Server
Processor	Intel® Xeon® processor E3-1200 product family
Chipset	Intel® C202
Memory	Up to 32GB (4 DIMM slots) 1GB/2GB/4GB/8GB DDR3 up to 1600MT/s
I/O slots	One PCIe x16 G2 slot
Optical Drive	DVD+/-RW
Drive bays	Up to two 3.5" drives
Embedded NIC	Broadcom NetXtreme 5709 Dual Port Gigabit Ethernet NIC, Copper, with TOE PCIe x4
Power supply	Single cabled power supply, 250W (80+ SILVER)
Operating system	Windows 7 Professional 64bit
Accessories	Keyboard and Mouse
Graphics Card	16GB 64-bit DDR PCI Express x1 Graphics Card
Weight	28lbs
Dimensions	1U Rack Mount
Warranty	Standard Dell 3 year next business day on-site service after remote diagnosis

*Monitor not included

Warranty terms and conditions:

3 Year Dell Hardware Limited Warranty includes On Site Next Business Day Service After Telephone Diagnosis. User must contact Video Insight for all warranty claims. End User may not be eligible for Dell On Site Warranty. Contact Video Insight for Storage warranty claims. Some storage may not be covered by Dell On Site Warranty.

Video Insight, Inc.
 3 Riverway, Suite 700
 Houston, TX 77056
 713.621.9779
www.video-insight.com
sales@video-insight.com

PreLoaded Network Video Recorder - 1U Rack Server with 4 Drive Bays

- Easy Installation
- IP Licenses Activated
- Tested and Configured
- Superior US-based Technical Support
- 3 Year Hardware Limited Warranty*
- 5 years VMS Software Upgrades Included



Video Insight NVR's come pre-loaded, activated and tested with the full Video Insight Software Suite. The "plug and play" NVRs are ready immediately out of the box for a quick start to record and view your cameras.

MODEL SPECIFICATIONS

Model	Total Storage	RAID Storage	RAM	Processor	Power Supply
NVR-R-1-1-8TB	8TB	5TB	4GB	Single	Single
NVR-R-1-1-12TB	12TB	8TB	4GB	Single	Single

SERVER SPECIFICATIONS

Dell PowerEdge R320 Class Server	
Processor	Intel® Xeon® processor E5-2400 and E5-2400 v2 product families
Internal interconnect	Intel® DMI 2.0
Chipset	Intel® C600
Memory	Up to 192GB (6 DIMM slots) 2GB/4GB/8GB/16GB/32GB DDR3 up to 1600M T/s
I/O slots	Two PCIe Slots
RAID Controller	PERC H710 Integrated RAID Controller
Optical Drive	DVD+/-RW
Drive bays	Up to four 3.5" drives
Embedded NIC	Broadcom® 5720 Dual Port 1Gb LOM
Power supply	Bronze efficiency, cabled 350W power supply
Operating system	Windows 2008 Server Web R2 64bit
Accessories	Keyboard and Mouse
Graphics Card	1GB 64-bit DDR PCI Express x1 Graphics Card
Weight	42lbs
Dimensions	1U Rack Mount
Warranty	Standard Dell 3 year next business day on-site service after remote diagnosis

*Monitor not included

Warranty terms and conditions:
 3 Year Dell Hardware Limited Warranty includes On Site Next Business Day Service After Telephone Diagnosis.
 User must contact Video Insight for all warranty claims.
 End User may not be eligible for Dell On Site Warranty.
 Contact Video Insight for Storage warranty claims. Some storage may not be covered by Dell On Site Warranty.

PreLoaded Network Video Recorder - 2U Rack Server with 8 Drive Bays

- Easy Installation
- IP Licenses Activated
- Tested and Configured
- Superior US-based Technical Support
- 3 Year Hardware Limited Warranty*
- 5 years VMS Software Upgrades Included



Video Insight NVR's come pre-loaded, activated and tested with the full Video Insight Software Suite. The "plug and play" NVRs are ready immediately out of the box for a quick start to record and view your cameras.

MODEL SPECIFICATIONS

Model	Total Storage	RAID Storage	RAM	Processor	Power Supply
NVR-R-1-1-16TB	16TB	13TB	4GB	Single	Single
NVR-R-2-2-16TB	16TB	13TB	8GB	Dual	Dual
NVR-R-1-1-24TB	24TB	19TB	4GB	Single	Single
NVR-R-2-2-24TB	24TB	19TB	8GB	Dual	Dual

SERVER SPECIFICATIONS

Dell PowerEdge R520 Class Server	
Processor	Intel® Xeon® processor E5-2400 and E5-2400 v2 product families
Internal interconnect	Intel® QuickPath Interconnect (QPI) link: 6.4GT/s; 7.2GT/s; 8.0GT/s
Chipset	Intel® C600
Memory	Up to 384GB (12 DIMM slots): 2GB/4GB/8GB/16GB/32GB DDR3 up to 1600MT/s
I/O slots	4x PCIe slots
RAID Controller	PERC H710 Integrated RAID Controller
Optical Drive	DVD+/-RW
Drive bays	Up to eight 3.5" drives
Embedded NIC	Broadcom 5720 Dual Port 1Gb
Power supply	Platinum efficiency, hot-plug redundant 495W or 750W power supply
Operating system	Windows 2008 Server Web R2 64bit
Accessories	Keyboard and Mouse
Graphics Card	1GB 64-bit DDR PCI Express x1 Graphics Card
Weight	64lbs
Dimensions	2U Rack Mount
Warranty	Standard Dell 3 year next business day on-site service after remote diagnosis

*Monitor not included

Warranty terms and conditions:
 3 Year Dell Hardware Limited Warranty includes On Site Next Business Day Service After Telephone Diagnosis.
 User must contact Video Insight for all warranty claims.
 End User may not be eligible for Dell On Site Warranty.
 Contact Video Insight for Storage warranty claims. Some storage may not be covered by Dell On Site Warranty.

Video Insight, Inc.
 3 Riverway, Suite 700
 Houston, TX 77056
 713.621.9779
www.video-insight.com
sales@video-insight.com

PreLoaded Network Video Recorder - 2U Rack Server with 12 Drive Bays

- Easy Installation
- IP Licenses Activated
- Tested and Configured
- Superior US-based Technical Support
- 3 Year Hardware Limited Warranty*
- 5 years VMS Software Upgrades Included



Video Insight NVR's come pre-loaded, activated and tested with the full Video Insight Software Suite. The "plug and play" NVRs are ready immediately out of the box for a quick start to record and view your cameras.

MODEL SPECIFICATIONS

Model	Total Storage	RAID Storage	RAM	Processor	Power Supply
NVR-R-2-2-36TB	36TB	27TB	8GB	Dual	Dual
NVR-R-2-2-48TB	48TB	37TB	8GB	Dual	Dual

SERVER SPECIFICATIONS

Dell PowerEdge R720xd Class Server	
Processor	Intel® Xeon® processors E5-2600 product family
Internal interconnect	2 x Intel® QuickPath Interconnect (QPI) links; 6.4 GT/s; 7.2 GT/s; 8.0 GT/s
Chipset	Intel® C600
Memory	Up to 768GB (24 DIMM slots) 2GB/4GB/8GB/16GB/32GB DDR3 up to 1866MT/s
I/O slots	6 PCIe slots
RAID Controller	PERC H710 Integrated RAID Controller
Optical Drive	External DVD+/-RW
Drive bays	Up to twelve 3.5" drives and two 2.5" drives (rear**)
Embedded NIC	Broadcom® 5720 quad-port 1GbE Base-T (no TOE or iSCSI offload)
Power supply	Platinum efficiency 495W, 750W or Platinum+ efficiency 1100W power supplies
Operating system	Windows 2008 Server Web R2 64bit
Accessories	Keyboard and Mouse
Graphics Card	1GB 64-bit DDR PCI Express x1 Graphics Card
Weight	79lbs
Dimensions	2U Rack
Warranty	Standard Dell 3 year next business day on-site service after remote diagnosis

*Monitor not included

**Rear drives are special order and requires extra time.

Warranty terms and conditions:

3 Year Dell Hardware Limited Warranty includes On Site Next Business Day Service After Telephone Diagnosis. User must contact Video Insight for all warranty claims. End User may not be eligible for Dell On Site Warranty. Contact Video Insight for Storage warranty claims. Some storage may not be covered by Dell On Site Warranty.

PreLoaded Network Video Recorder - Tower Server with 8 Drive Bays

- Easy Installation
- IP Licenses Activated
- Tested and Configured
- Superior US-based Technical Support
- 3 Year Hardware Limited Warranty*
- 5 years VMS Software Upgrades Included



Video Insight NVR's come pre-loaded, activated and tested with the full Video Insight Software Suite. The "plug and play" NVRs are ready immediately out of the box for a quick start to record and view your cameras.

MODEL SPECIFICATIONS

Model	Total Storage	RAID Storage	RAM	Processor	Power Supply
NVR-T-1-1-8TB	8TB	5TB	4GB	Single	Single
NVR-T-1-1-12TB	12TB	8TB	4GB	Single	Single

SERVER SPECIFICATIONS

Dell PowerEdge T320 Class Server	
Processor	Intel® Xeon® processor E5-2400 and E5-2400 v2 product families
Internal interconnect	Intel® DMI 2.0
Chipset	Intel® C600
Memory	Up to 192GB (6 DIMM slots) 2GB/4GB/8GB/16GB/32GB DDR3 up to 1600M T/s
I/O slots	Five PCIe Slots
RAID Controller	PERC H710 Integrated RAID Controller
Optical Drive	DVD+/-RW
Drive bays	Up to eight 3.5" drives
Embedded NIC	Broadcom® 5720 Dual Port 1Gb LOM
Power supply	Platinum efficiency, hot-plug, 495W or 750W power supply
Operating system	Windows 2008 Server Web R2
Accessories	Keyboard and Mouse
Graphics Card	1GB 64-bit DDR PCI Express x1 Graphics Card
Weight	61lbs
Dimensions	8.75" x 17.5" x 22.25" Tower (5U rackable)
Warranty	Standard Dell 3 year next business day on-site service after remote diagnosis

*Monitor not included

Warranty terms and conditions:
 3 Year Dell Hardware Limited Warranty includes On Site Next Business Day Service After Telephone Diagnosis.
 User must contact Video Insight for all warranty claims.
 End User may not be eligible for Dell On Site Warranty.
 Contact Video Insight for Storage warranty claims. Some storage may not be covered by Dell On Site Warranty.

PreLoaded Network Video Recorder - Tower with 2 Drive Bays

- Easy Installation
- IP Licenses Activated
- Tested and Configured
- Superior US-based Technical Support
- 3 Year Hardware Limited Warranty*
- 5 years VMS Software Upgrades Included



Video Insight NVR's come pre-loaded, activated and tested with the full Video Insight Software Suite. The "plug and play" NVRs are ready immediately out of the box for a quick start to record and view your cameras.

MODEL SPECIFICATIONS

Model	Total Storage	RAM	Processor	Power Supply
NVR-T-1-1-500GB	500GB	4GB	Single	Single
NVR-T-1-1-1TB	1TB	4GB	Single	Single
NVR-T-1-1-2TB	2TB	4GB	Single	Single
NVR-T-1-1-3TB	3TB	4GB	Single	Single
NVR-T-1-1-4TB	4TB	4GB	Single	Single

SERVER SPECIFICATIONS

Dell OptiPlex 7010 Class Server	
Processor	Intel® Core™ i5 Quad Core Processor
Chipset	Intel® Q77 Express Chipset
Memory	Four DIMM slots; Non-ECC dual-channel 1333MHz and 1600MHz DDR3 SDRAM, up to 8GB
I/O slots	4x PCIe slots
Optical Drive	DVD+/-RW
Drive bays	Up to two 3.5" drives
Embedded NIC	Integrated Intel® 82579LM Ethernet LAN 10/100/1000
Power supply	Standard 275W PSU Active PFC or optional 275W up to 90% Efficient PSU (80 PLUS Gold)
Operating system	Windows 7 Professional 64bit
Accessories	Keyboard and Mouse
Weight	28lbs
Dimensions	14.25" x 7.0" x 16.25"
Warranty	Standard Dell 3 year next business day on-site service after remote diagnosis

*Monitor not included

Warranty terms and conditions:

3 Year Dell Hardware Limited Warranty includes On Site Next Business Day Service After Telephone Diagnosis. User must contact Video Insight for all warranty claims. End User may not be eligible for Dell On Site Warranty. Contact Video Insight for Storage warranty claims. Some storage may not be covered by Dell On Site Warranty.

PreLoaded Network Video Recorder - 2U Rack Server with 8 Drive Bays

- Easy Installation
- IP Licenses Activated
- Tested and Configured
- Superior US-based Technical Support
- 3 Year Hardware Limited Warranty*
- 5 years VMS Software Upgrades Included



Video Insight NVR's come pre-loaded, activated and tested with the full Video Insight Software Suite. The "plug and play" NVRs are ready immediately out of the box for a quick start to record and view your cameras.

MODEL SPECIFICATIONS

Model	Total Storage	RAID Storage	RAM	Processor	Power Supply
NVR-T-1-1-16TB	16TB	14TB	4GB	Single	Single
NVR-T-2-2-16TB	16TB	14TB	8GB	Dual	Dual
NVR-T-1-1-24TB	24TB	21TB	4GB	Single	Single
NVR-T-2-2-24TB	24TB	21TB	8GB	Dual	Dual

SERVER SPECIFICATIONS

Dell PowerEdge T620 Class Server	
Processor	Intel® Xeon® E5-2603 1.80GHz, 10M Cache, 6.4GT/s QPI, No Turbo, 4C, 80W
Internal interconnect	Intel DMI 2.0
Chipset	Intel C600
Memory	Up to 192GB (6 DIMM slots): 2GB/4GB/8GB/16GB/32GB DDR3 up to 1600MT/s
I/O slots	5 PCIe slots
RAID Controller	PERC H310 Integrated RAID Controller
Optical Drive	DVD+/-RW
Drive bays	Up to eight 3.5" drives
Embedded NIC	Broadcom® 5720 Dual Port 1GbE BASE-T
Power supply	Platinum efficiency 750W
Operating system	Windows 2008 Server Web R2
Accessories	Keyboard and Mouse
Graphics Card	1GB 64-bit DDR PCI Express x1 Low Profile Video Card
Weight	64.9 lbs
Dimensions	11.98" x 17.45" x 22.77"
Warranty	Standard Dell 3 year next business day on-site service after remote diagnosis

*Monitor not included

Warranty terms and conditions:
 3 Year Dell Hardware Limited Warranty includes On Site Next Business Day Service After Telephone Diagnosis.
 User must contact Video Insight for all warranty claims.
 End User may not be eligible for Dell On Site Warranty.
 Contact Video Insight for Storage warranty claims. Some storage may not be covered by Dell On Site Warranty.

Overview

- 1.3 megapixel high resolution
- PoE (Power over Ethernet)
- Progressive scan CMOS
- Back Light Compensation
- IR Range up to 30m
- Weather Proof Rating: IP66
- Vandal Proof: IK 10 Rated
- Video Insight VMS license included



Technical Specifications

Camera

Image Sensor:	1/3" Progressive Scan CMOS
Min. Illumination:	0.01 lux@F1.2, AGC ON 0.028 lux@F2.0, AGC ON 0 lux with IR
Shutter Time:	1/25s ~ 1/100,000s
Lens:	mm@F2.0
Angle of View:	52°
Lens Mount:	M12
Angle Adjustment:	Pan: 0° ~ 355°, tilt: 0° ~ 90°
Day & Night:	ICR

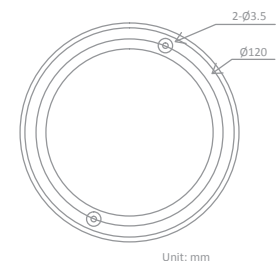
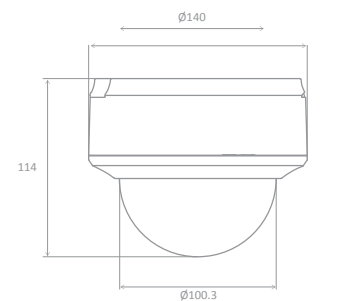

Unit: mm

Compression Standard

Video Compression:	H.264/MJPEG
Bit Rate:	32 Kbps ~ 16 Mbps
Audio Compression:	G.711
Dual Stream:	Yes

Image

Max. Image Resolution:	1280 x 960
Frame Rate:	30 FPS (1280 x 960), 30 FPS (1280 x 720)
Image Setting:	Saturation, Brightness, Contrast adjustable through client software or web browser

Network

Network Storage:	Built-in SD/SDHC slot, up to 32 GB
Alarm Trigger:	Motion detection, tampering alarm, network disconnect, IP address conflict, storage exception
Protocols:	TCP/IP, HTTP, DHCP, DNS, DDNS, RTP, RTSP, PPPoE, SMTP, NTP, SNMP, HTTPS, FTP, 802.1x, Qos (SIP, SRTP, IPv6 optional)
Security:	User authentication, reset button, flickerless, dual stream, heartbeat, mirror, watermark

Interface

Communication Interface:	1 RJ45 10 M/100 M Ethernet interface
--------------------------	--------------------------------------

Technical Specifications

General

Operating Conditions:	14° F – 140° F Humidity 95% or less (non-condensing)
Power Supply:	12 VDC ± 10%, PoE (802.3af)
Power Consumption:	Max. 5.5W
Impact Protection:	IEC60068-275Eh, 50J; EN50102, up to IK10
IR Range:	Up to 60 ft.
Dimensions:	Φ 4.37" × 3.23"
Weight:	1.1 lbs
Software:	WDR

Overview

- Up to 1.3 megapixel resolution
- Standard H.264 video compression with high compression ratio
- Progressive scan CMOS
- Day / Night
- PoE
- IR Range up to 30m
- Weather Proof Rating: IP66
- Video Insight VMS license included



Technical Specifications

Camera

Image Sensor:	1/3" Progressive Scan CMOS
Min. Illumination:	0.01 lux 0.028 lux
Shutter Time:	1/25 s to 1/100,000 s
Lens:	6 mm @ F2.0
Angle of View:	45.3 °
Lense Mount:	M12
Day & Night:	IR cut filter with auto switch

Compression Standard

Video Compression:	H.264 / MJPEG
Bit Rate:	32 Kbps ~ 16 Mbps
Dual Stream:	Yes

Image

Max. Image Resolution:	1280 x 960
Frame Rate:	30 FPS (1280 x 960), 30 FPS (1280 x 720)
Image Settings:	Saturation, Brightness, Contrast adjustable through client software or web browser

Network

Network Storage:	NAS (iSCSI optional)
Alarm Trigger:	Motion detection, tampering alarm, network disconnect, IP address conflict, storage exception
Protocols:	TCP/IP, HTTP, DHCP, DNS, DDNS, RTP, RTSP, PPPoE, SMTP, NTP, SNMP, HTTPS, FTP, 802.1x, Qos (SIP, SRTP, IPv6 optional)
Security:	User Authentication, reset button, flickerless, dual stream, heartbeat, mirror, watermark
System Compatibility:	ONVIF, PSIA, CGI

Technical Specifications

Interface

Communication Interface:	1 RJ45 10M / 100M ethernet port
Reset Button:	Yes

General

Operating Conditions:	14° F – 140° F Humidity 90% or less (non-condensing)
Power Supply:	12 VDC ± 10%, PoE (802.3af)
Power Consumption:	Max. 5.5W (ICR on: Max8.5W)
Software:	WDR
Weather Proof Rating:	IP66
Dimensions:	2.38" × 3.01" × 5.44"
Weight:	0.66LBS

Overview

- 3 mega-pixel high resolution
- PoE (Power over Ethernet)
- Progressive scan CMOS
- WDR
- IR Range up to 30m
- Weather Proof Rating: IP66
- Vandal Proof: IK 10 Rated
- Video Insight VMS license included



Technical Specifications

Camera

Image Sensor:	1/3" Progressive Scan CMOS
Min. Illumination:	0.05Lux 0.15Lux
Shutter Time:	1/25s ~ 1/100,000s
Lens:	4mm
Angle of View:	71°
Lens Mount:	M12
Angle Adjustment:	Pan: 0° ~ 355°, tilt: 0° ~ 90°
Day & Night:	IR cut-filter with auto switch

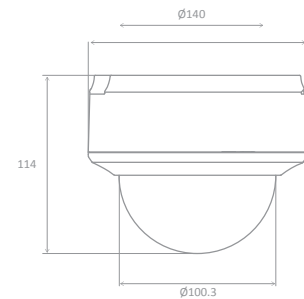

Compression Standard

Video Compression:	H.264/MJPEG
Bit Rate:	32 K bps ~ 16 Mbps
Dual Stream:	Yes

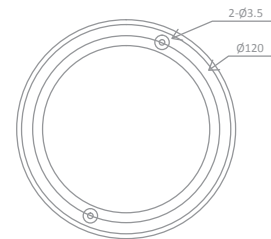

Unit: mm

Image

Max. Image Resolution:	2048 X 1536
Frame Rate:	50Hz: 12.5 FPS(2048 x 1536), FPS(1920 x 1080), FPS(1280 x 720) 60Hz: FPS(2048 x 1536), FPS(1920 x 1080), FPS(1280 x 720)

Image Setting: Saturation, Brightness, Contrast adjustable through client software or web browser

Network

Network Storage:	NAS (iSCSI optional)
Alarm Trigger:	Motion detection, tampering alarm, network disconnect, IP address conflict, storage exception
Protocols:	TCP/IP, HTTP, DHCP, DNS, DDNS, RTP, RTSP, PPPoE, SMTP, NTP, SNMP, HTTPS, FTP, 802.1x, Qos (SIP, SRTP, IPv6 optional)
Security:	User authentication, reset button, flicker-less, dual stream, heartbeat, mirror, watermark
System Compatibility:	ONVIF, PSIA, CGI

Interface

Communication Interface:	1 RJ45 10 M/100 M Ethernet interface
--------------------------	--------------------------------------

Technical Specifications

General

Operating Conditions:	14° F – 140° F Humidity 95% or less (non-condensing)
Power Supply:	12 VDC ± 10%, PoE (802.3af)
Power Consumption:	Max. 5W
Weather Proof Rating:	IP66
IR Range:	Up to 60 ft.
Dimensions:	2.38" × 3.01" × 5.44"
Weight:	0.66 Lbs
DWR:	120db

Overview

- 3 mega-pixel high resolution
- PoE (Power over Ethernet)
- Progressive scan CMOS
- WDR
- IR Range up to 30m
- Weather Proof Rating: IP66
- Vandal Proof: IK 10 Rated
- Video Insight VMS license included



Technical Specifications

Camera

Image Sensor:	1/3" Progressive Scan CMOS
Min. Illumination:	0.05Lux 0.15Lux
Shutter Time:	1/25s ~ 1/100,000s
Lens:	2.8mm
Angle of View:	118°
Lens Mount:	M12
Angle Adjustment:	Pan: 0° ~ 355°, tilt: 0° ~ 90°
Day & Night:	IR cut-filter with auto switch

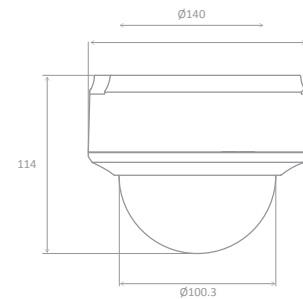

Compression Standard

Video Compression:	H.264/MJPEG
Bit Rate:	32 K bps ~ 16 Mbps
Dual Stream:	Yes

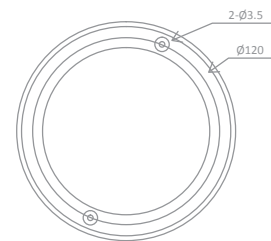

Unit: mm

Image

Max. Image Resolution:	2048 X 1536
Frame Rate:	50Hz: 12.5 FPS(2048 x 1536), FPS(1920 x 1080), FPS(1280 x 720) 60Hz: FPS(2048 x 1536), FPS(1920 x 1080), FPS(1280 x 720)

Image Setting: Saturation, Brightness, Contrast adjustable through client software or web browser

Network

Network Storage:	NAS (iSCSI optional)
Alarm Trigger:	Motion detection, tampering alarm, network disconnect, IP address conflict, storage exception
Protocols:	TCP/IP, HTTP, DHCP, DNS, DDNS, RTP, RTSP, PPPoE, SMTP, NTP, SNMP, HTTPS, FTP, 802.1x, Qos (SIP, SRTP, IPv6 optional)
Security:	User authentication, reset button, flicker-less, dual stream, heartbeat, mirror, watermark
System Compatibility:	ONVIF, PSIA, CGI

Interface

Communication Interface:	1 RJ45 10 M/100 M Ethernet interface
--------------------------	--------------------------------------

Technical Specifications

General

Operating Conditions:	14° F – 140° F Humidity 95% or less (non-condensing)
Power Supply:	12 VDC ± 10%, PoE (802.3af)
Power Consumption:	Max. 5W
Weather Proof Rating:	IP66
IR Range:	Up to 60 ft.
Dimensions:	2.38" × 3.01" × 5.44"
Weight:	0.66 Lbs
DWR:	120db

Overview

- Up to 3 megapixel resolution
- Standard H.264 video compression with high compression ratio
- Progressive scan CMOS
- WDR
- Day / Night
- PoE
- IR Range up to 30m
- Weather Proof Rating: IP66
- Video Insight VMS license included



Technical Specifications

Camera

Image Sensor:	1/3" Progressive Scan CMOS
Min. Illumination:	0.05 lux 0.15 lux
Shutter Time:	1/25 s to 1/100,000 s
Lens:	6 mm @ F2.0
Angle of View:	45.3 °
Lense Mount:	M12
Day & Night:	IR cut filter with auto switch

Compression Standard

Video Compression:	H.264 / MJPEG
Bit Rate:	32 Kbps ~ 16 Mbps
Dual Stream:	Yes

Image

Max. Image Resolution:	2048 x 1536
Frame Rate:	50Hz: 12.5 FPS(2048 x 1536), 25 FPS(1920 x 1080), 25 FPS(1280 x 720) 60Hz: 15 FPS(2048 x 1536), 30 FPS(1920 x 1080), 30 FPS(1280 x 720)
Image Settings:	Saturation, Brightness, Contrast adjustable through client software or web browser

Network

Network Storage:	NAS (iSCSI optional)
Alarm Trigger:	Motion detection, tampering alarm, network disconnect, IP address conflict, storage exception
Protocols:	TCP/IP, HTTP, DHCP, DNS, DDNS, RTP, RTSP, PPPoE, SMTP, NTP, SNMP, HTTPS, FTP, 802.1x, Qos (SIP, SRTP, IPv6 optional)
Security:	User Authentication, reset button, flickerless, dual stream, heartbeat, mirror, watermark

System Compatibility:

ONVIF, PSIA, CGI

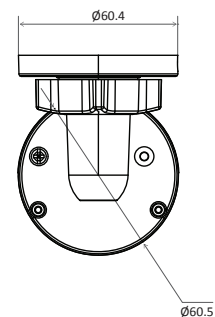
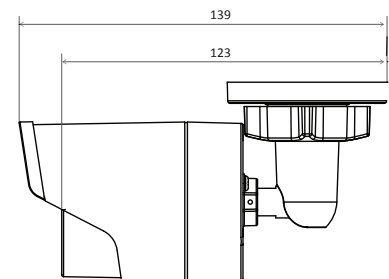
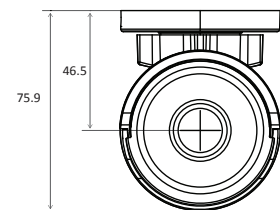

Unit: mm

Technical Specifications

Interface

Communication Interface:	1 RJ45 10M / 100M ethernet port
Reset Button:	Yes

General

Operating Conditions:	14° F – 140° F Humidity 90% or less (non-condensing)
Power Supply:	12 VDC ± 10%, PoE (802.3af)
Power Consumption:	Max. 5W
WDR	120DB
Weather Proof Rating:	IP66
Dimensions:	2.38" × 3.01" × 5.44"
Weight:	0.66 lbs

Overview

- Up to 2 Megapixel resolution
- Remote Focus
- H.264 MPEG4 / MJPEG Video Compression
- Dual stream
- Progressive scan CMOS
- On-board motion detection
- Two-way audio
- PoE
- SD Card
- Compatible with ONVIF & PSIA standard
- Video Insight VMS license included



Technical Specifications

Camera

Image Sensor:	1/3" Progressive Scan CMOS
Min. Illumination:	0.5 lux@F1.2, AGC on, 0.1 lux@F1.2, AGC on
Shutter Time:	1/25s ~ 1/100,000s
Lens:	2.7 ~ 9 mm @F1.2 Angle of view: 101° ~ 30.4° Remote focus
Lens Mount:	φ 14
Auto Iris:	DC drive
Adjustment Range:	Pan: 0° ~ 360°, tilt: 0° ~ 75°, rotation: 0° ~ 360°
Day & Night:	Electronic (IR cut filter with auto switch)

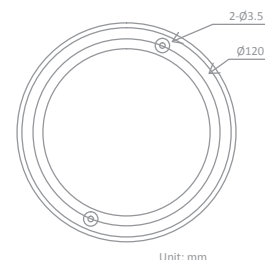
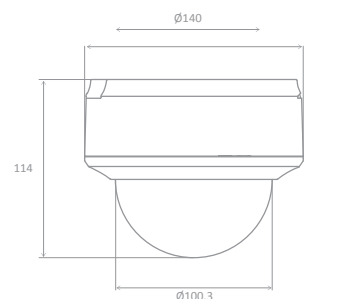

Compression Standard

Video Compression:	MJPEG / MPEG4 / H.264
Bit Rate:	32 Kbps ~ 16 Mbps
Audio Compression:	G.711
Dual Stream:	Yes

Image

Frame Rate:	60HZ: 25 FPS(1280x720), 25FPS(1280x960), 12.5 FPS(1600x1200), 30FPS(704x480)
-------------	---

Network

Alarm Trigger:	Motion detection, network disconnect, IP address conflict, storage exception
Protocols:	NTP, SMTP, PPPoE, RTP/RTSP, DDNS, DNS, DHCP, HTTP, TCP/IP (SNMP, HTTPS, SIP, FTP, SRTP, 802.1X, IPV6 optional)
Security:	Password protection and watermark
System Compatibility:	ONVIF, PSIA, CGI

Interface

Audio Input:	1-ch microphone input, 3.5mm mini-jack
Audio Output:	1-ch 3.5mm audio interface (line level, 600 Ω)
Communication Interface:	1 RJ45 10 / 100 ethernet interface and 1 RS-485 interface
Alarm Input:	2
Alarm Output:	2

Technical Specifications

Reset Button:	Yes
Video Output:	1Vp-p Composite Output (750hm, RCA)
Local Storage:	Built-in SD / SDHC slot, up to 32 GB
General	
Operating Conditions:	-10° C ~ 60° C (14° F ~ 140° F) Humidity 90% or less (non-condensing)
Power Supply:	12 VDC ± 10%, PoE (802.3af)
Power Consumption:	4.5W max. 6W max. (6.5W max. with IR cut filter on)
Impact Protection:	IEC60068-2-75Eh, 50J, EN50102, up to IK10
IR Range:	Approx 10 to 20 meters (32.8-65.6ft)
Dimensions:	Φ 140mm×114mm (Φ5.51"×4.49")
Weight:	1400g (3.09 lbs)

Overview

- Up to 2 megapixel resolution
- Remote Focus
- MJPEG / MPEG4 / H.264 Video Compression with high compression ratio
- Progressive scan CMOS
- Up to 32 GB SD/SDHC card local storage
- Two-way audio
- PoE
- Conforms to ONVIF and PSIA
- Compatible with ONVIF & PSIA standard
- Dual Stream
- Video Insight VMS license included



Technical Specifications

Camera

Image Sensor:	1/3" Progressive Scan CMOS
Min. Illumination:	0 lux
Shutter Time:	1/25s ~ 1/100,000s
Lens:	2.7 ~ 9 mm @F1.2 Angle of view: 101° ~ 30.4°
Lens Mount:	φ14
Auto Iris:	DC drive
Adjustment Range:	Pan: 0° ~ 360°, tilt: 0° ~ 75°, rotation: 0° ~ 360°
Day & Night:	Electronic (IR cut filter with auto switch)

Compression Standard

Video Compression:	MJPEG / MPEG4 / H.264
Bit Rate:	32 K bps ~ 16 Mbps
Audio Compression:	G.711
Dual Stream:	Yes

Image

Max. Image Resolution:	1600 X 1200
Frame Rate:	60Hz: 30 FPS(1280x720), 15 FPS(1600x1200)
Image Setting:	Saturation, Brightness, Contrast adjustable through client software or web browser

Network

Local Storage:	Built-in SD/SDHC slot, up to 32 GB
Alarm Trigger:	Motion detection, network disconnect, IP address conflict, storage exception
Protocols:	NTP, SMTP, PPPoE, RTP/RTSP, DDNS, DNS, DHCP, HTTP, TCP/IP
Security:	Password protection and watermark

Interface

System Compatibility:	ONVIF, PSIA, CGI
Audio Input:	1-ch microphone input, 3.5mm mini-jack
Audio Output:	1-ch 3.5mm audio interface (line level, 600 Ω)

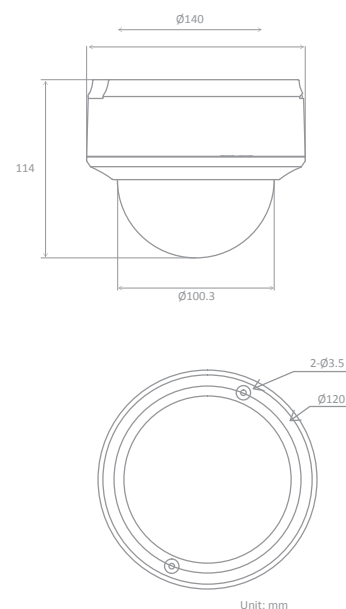

Technical Specifications

Communication Interface:	1 RJ45 10 / 100 ethernet interface and 1 RS-485 interface
Alarm Input:	2
Alarm Output:	2
Reset Button:	Yes
General	
Operating Conditions:	-10° C ~ 60° C (14° F ~ 140° F) Humidity 90% or less (non-condensing)
Power Supply:	12 VDC ± 10%, PoE (802.3af)
Power Consumption:	6.5W max. 6W max. (6.5W max. with IR cut filter on)
Impact Protection:	IEC60068-2-75Eh, 50J, EN50102, up to IK10
IR Range:	Up to 60 ft.
Dimensions:	Φ 5.51" × 4.49"
Weight:	3.09 Lbs

Overview

- 1/3" progressive scan CMOS
- Remote Focus
- MJPEG / MPEG4 / H.264 video compression
- Up to 2 MP (1600 × 1200) resolution
- True day / night
- IP66 rating
- Video Insight VMS license included



Technical Specifications

Camera

Image Sensor:	1/3" Progressive Scan CMOS
Min. Illumination:	0.5 lux @F1.2, AGC on 0.1 lux @F1.2, AGC on, sens-up × 5 0 lux with IR
Shutter Time:	1/25s ~ 1/100,000s
Lens:	2.7 ~ 9 mm @F1.2 Angle of view: 101° ~ 30.4° Remote focus
Lens Mount:	φ 14
Day & Night:	IR cut filter with switch
Video Compression:	MJPEG / MPEG4 / H.264
Bit Rate:	32 Kbps ~ 16 Mbps
Dual Stream:	Yes
Max. Image Resolution	1600 x 1200

Image

Frame Rate:	60Hz: 30 FPS(1280 x 720), 25 FPS(1280 x 960), 15 FPS(1600 x 912), 15 FPS(1600 x 1200)
-------------	--

Network

Network Storage:	NAS
Alarm Trigger:	Motion detection, network disconnect, IP address conflict, storage exception
Protocols:	NTP, SMTP, PPPoE, RTP/RTSP, DDNS, DNS, DHCP, HTTP, TCP/IP (SNMP, HTTPS, SIP, FTP, SRTP, 802.1X, IPV6 optional)
Security:	Password protection and watermark

Interface

Communication Interface:	1 RJ45 10 / 100 ethernet interface
--------------------------	------------------------------------

General

Operating Conditions:	14 ° F ~ 140° F Humidity 90% or less (non-condensing)
Power Supply:	12 VDC ± 10%, PoE (802.3af)
Power Consumption:	8.5W max.
Impact Protection:	IEC60068-2-75Eh, 50J, EN50102, up to IK10
IR Range:	Approx 65-98 ft.
Dimensions:	3.86" x 3.49" x 12.94"
Weight:	3.75 lbs

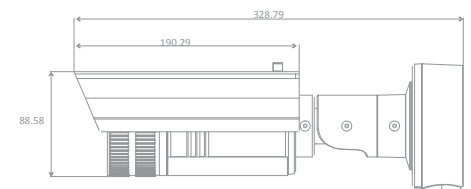
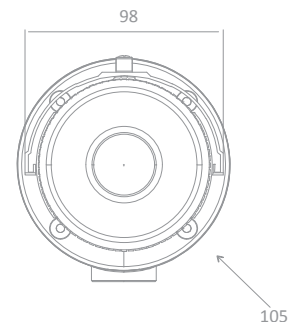

Unit: mm

Overview

- Up to 2 megapixel resolution
- Real time video at HD 720p
- Standard H.264 video compression with high compression ratio
- Progressive scan CMOS
- Support ePTZ function
- 3-axis (pan/tilt/rotation) positioning
- Weather Proof Rating: IP66
- Impact Protection: IEC60068-2-75 test, Eh, 50J; EN50102, up to IK10
- Video Insight VMS license included



Technical Specifications

Camera

Image Sensor:	1/3" Progressive Scan CMOS
Effective Pixels:	1600 X 1200
Min. Illumination:	0.5 lux @ (F1.2, AGC ON), 0.1 lux @ (F1.2, AGC ON, sensitivity x 5) 1.1 lux @ (F1.8, AGC ON), 0.2 lux @ (F1.8, AGC ON, sensitivity x 5)
Shutter Time:	1/25 s to 1/100,000 s
Lens:	4 mm @ F1.8
Angle of View:	71°
Lens Mount:	M12
Angle Adjustment:	Pan: ± 15°, Tilt: 0 - 90°, Rotation: ± 15°
Day & Night:	Electronic

Compression Standard

Video Compression:	MJPEG / MPEG4 / H.264
Bit Rate:	32 K bps ~ 16 Mbps
Dual Stream:	Yes

Image

Max. Image Resolution:	1600 X 1200
Frame Rate:	60 Hz: 15 FPS(1600 x 1200), 15 FPS(1600 x 912), 25 FPS(1280 x 960), 30 FPS(1280 x 720) 50 Hz: 12.5 FPS(1600 x 1200), 12.5 FPS(1600 x 912), 25 FPS(1280 x 960), 25 FPS(1280 x 720)
Image Settings:	Saturation, Brightness, Contrast adjustable through client software or web browser

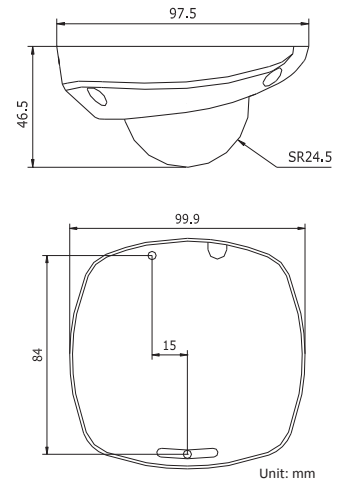

Technical Specifications

Network	
Network Storage:	NAS (iSCSI optional)
Alarm Trigger:	Motion detection
Protocols:	NTP, SMTP, PPPoE, RTP/RTSP, DDNS, DNS, DHCP, HTTP, TCP-IP (IPv6, 802.1X, SRTP, FTP, SIP, HTTPS, SNMP optional)
Security:	Password protection and watermark
System Compatibility:	ONVIF, PSIA, CGI
Interface	
Communication Interface:	1 RJ45 10 M/100 M Ethernet port
Reset Button:	Yes
Local Storage:	Micro SD / MicroSDHC memory card slot (card not included)
General	
Operating Conditions:	14° F – 140° F Humidity 90% or less (non-condensing)
Power Supply:	12 VDC ± 10%, PoE (802.3af)
Power Consumption:	Max. 4W
Impact Protection:	IEC60068-275Eh, 50J; EN50102, up to IK10
Weather Proof Rating:	IP66
Dimensions:	3.93" × 3.84" × 1.83"
Weight:	0.55 Lbs

Overview

- Up to 3 megapixel (2048 x 1536) resolution
- Full HD1080p real-time video
- DWDR & 3D DNR & BLC
- Onboard storage (up to 64 GB)
- IP66 protection
- Vandal-proof housing



Technical Specifications

Camera

Image Sensor:	1/3" Progressive Scan CMOS
Min. Illumination:	0.19lux @ F2.0, AGC on 0 lux with IR
Shutter Time:	1/30s ~ 1/100,000s
Lens:	4mm@F2.0, angle of view: 75.8° (2.8mm, 6mm optional)
Lens Mount:	M12
Day & Night:	ICR
Digital Noise Reduction:	3D DNR
Wide Dynamic Range:	Digital WDR
Backlight Compensation	Yes, zone configurable

Compression Standard

Video Compression:	H.264/MJPEG
H.264 Compression Profile:	Main Profile
Bit Rate:	32 Kbps ~ 16Mbps

Image

Max. Image Resolution:	2048 x 1536
Frame Rate:	60Hz: 15fps (2048 x 1536), 30fps (1920 x 1080), 30fps (1280 x 720)
Image Setting:	Saturation, brightness, contrast adjustable through client software or web browser

Network

Network Storage:	NAS
Alarm Trigger:	Motion detection, tampering alarm, network disconnect, IP address conflict, storage exception, storage error
Protocols:	TCP/IP, HTTP, DHCP, DNS, DDNS, RTP, RTSP, PPPoE, SMTP, NTP, SNMP, HTTPS, FTP, 802.1x, Qos
System Compatibility:	ONVIF, PSIA, CGI
General Functionalities:	Flickerless, dual stream, heartbeat, mirror, user authentication, video mask, watermark

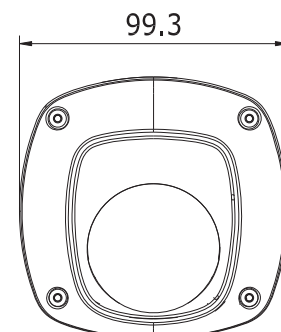
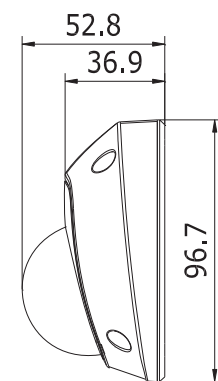
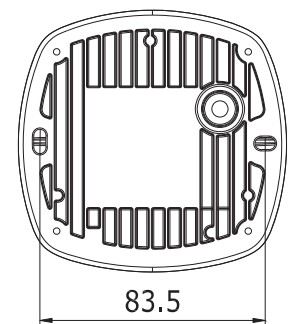

Unit: mm

Technical Specifications

Interface	
Communication Interface:	1 RJ45 10M / 100M ethernet port
On-board Storage:	Built-in Micro SD card slot, up to 64 GB
General	
Operating Conditions:	-30 °C ~ 60 °C (-22 °F ~ 140 °F), humidity 95% or less (non-condensing)
Power Supply:	DC12V ± 10%, PoE (802.3af)
Power Consumption:	Max. 7W
Impact Protection:	IEC60068-2-75Eh, 50J; EN50102, up to IK10
Ingress protection level	IP66
IR Range:	Up to 10m
Dimensions:	99.9 × 97.5 × 46.5 mm (3.93" × 3.84" × 1.83")
Weight:	250g (0.55 lbs)

Overview

- 3 megapixel resolution
- Motorized VF lens
- H.264 / MJPEG video compression
- WDR
- Progressive scan CMOS
- 3D digital noise reduction
- Two-way audio
- PoE
- Vandal-proof housing
- Compatible with CGI, ONVIF & PSIA standard
- Video Insight VMS license included



Technical Specifications

Camera

Image Sensor:	1/3" Progressive Scan CMOS
Min. Illumination:	0.1 lux @ (F1.2, AGC ON) 0.17lux @ (F1.6, AGC ON) 0 lux with IR
Shutter Time:	1/25s ~ 1/100,000s
Lens:	2.7 ~ 9 mm @F1.2 Angle of view: 101° ~ 30.4° Remote focus
Lens Mount:	φ14
Auto Iris:	DC drive
Angle Adjustment:	Pan: 0° ~ 360°, tilt: 0° ~ 75°, rotation: 0° ~ 360°
WDR Range:	120db
Day & Night:	Electronic (IR cutfilter with auto switch)

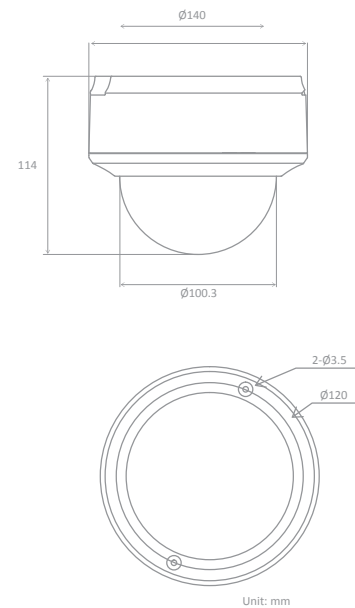

Compression Standard

Video Compression:	H.264/MPEG4/MJPEG
Bit Rate:	32 Kbps ~ 16 Mbps
Dual Stream:	Yes

Image

Max. Image Resolution:	2048 x 1536
Frame Rate:	50Hz: 12.5FPS(2048 x 1536), 25FPS(1920 x 1080), 25FPS(1280 x 720) 60Hz: 15FPS(2048 x 1536), 30FPS(1920 x 1080), 30FPS(1280 x 720)
Image Setting:	Saturation, Brightness, Contrast adjustable through client software or web browser

Network

Network Storage:	NAS (iSCSI optional)
Alarm Trigger:	Motion detection, tampering alarm, network disconnect, IP address conflict, storage exception
Protocols:	NTP, SMTP, PPPoE, RTP/RTSP, DDNS, DNS, DHCP, HTTP, TCP/IP (SNMP, HTTPS, SIP, FTP, SRTP, 802.1X, IPV6 optional)
Security:	User Authentication, Watermark

Technical Specifications

System Compatibility:	ONVIF, PSIA, CGI
Interface	
Audio Input:	1-ch microphone input, 3.5mm mini-jack
Audio Output:	1-ch 3.5mm audio interface (line level, 600 Ω)
Communication Interface:	1 RJ45 10 / 100 ethernet interface and 1 RS-485 interface
Alarm Input:	2
Alarm Output:	2
Video Output:	1Vp-p Composite Output (750hm, RCA)
Local Storage:	Built-in SD / SDHC slot, up to 32 GB
Reset Button:	Yes
General	
Operating Conditions:	-10° C ~ 60° C (14° F ~ 140° F) Humidity 90% or less (non-condensing)
Power Supply:	12 VDC ± 10%, PoE (802.3af)
Power Consumption:	5.5W~10.5W (IR: 2W, Motorized VF lens: 3W)
Impact Protection:	IEC60068-2-75Eh, 50J, EN50102, up to IK10
Weather Proof Rating	IP66
IR Range:	Approx 10 to 20 meters (32.8-65.6ft)
Dimensions:	Φ140mm×114mm (Φ5.51"×4.49")
Weight:	3.09 lbs

Overview

- Up to 2 megapixel resolution
- Standard H.264 video compression with high compression ratio
- Progressive scan CMOS
- High Speed PTZ
- 20x Optical Zoom
- WDR and auto/manual day & night switch
- Weather Proof Rating: IP66
- Video Insight VMS license included



Technical Specifications

Camera

Image Sensor:	1/3" Progressive Scan CMOS
Min. Illumination:	0.05Lux@F1.6
Shutter Time:	50Hz: 1/25-1/10,000s 60Hz: 1/30-1/10,000s
Lens:	4.7-94mm, 20x optical zoom
Angle of View:	58.3-3.2 degree (Wide-Tele)
Mount Options:	Long-arm wall mount, Corner mount, Pole Mount, Power box mount
Zoom Speed:	Approx.2.7s(Optical Wide-Tele)
Pan Range:	360° endless
Aperture Range:	F1.6-F3.5
Day & Night:	IR cut filter with auto switch

Compression Standard

Video Compression:	H.264 / MJPEG / MPEG4
--------------------	-----------------------

Image

Max. Image Resolution:	1920 x 1080
Frame Rate:	50Hz: 25 FPS(1920×1080) 25 FPS(1280×960) 25 FPS(1280×720) 60Hz: 30 FPS(1920×1080) 30 FPS(1280×960) 30 FPS(1280×720)

Network

Ethernet:	1 RJ45 10M / 100M ethernet port
Alarm Trigger:	Motion detection, tampering alarm, network disconnect, IP address conflict, storage exception
Protocols:	IPv4,HTTP,HTTPS,802.1x,Qos,FTP,SMTP,UPnP,SNMP,DNS,DDNS,NTP,RTSP,RTP,TCP,UDP,IGMP,ICMP,DHCP,PPPoE
Security:	User Authentication, reset button, flickerless, dual stream, heartbeat, mirror, watermark
System Compatibility:	ONVIF, PSIA, CGI

Technical Specifications

Interface

Communication Interface:	1 RJ45 10M / 100M ethernet port
Reset Button:	Yes

General

Operating Conditions:	-22° F – 149° F (Outdoor Dome) -14° F – 122° F (Indoor Dome) Humidity 90% or less (non-condensing)
Power Supply:	24 VAC
Power Consumption:	Max. 40W
WDR	120DB
Weather Proof Rating:	IP66
Dimensions:	12.81" × 8.66" Φ
Weight:	11.02 lbs
WDR:	120db

Overview

- 1/3.2" Progressive Scan CMOS
- 4 megapixel Resolution
- Day and night function with mechanical IR cut filter
- Minimum illumination 0.05 lux at F1.4
- 3.6 x optical zoom
- Built-in f3.3-12 mm / F1.4 megapixel P-Iris zoom lens
- 8 FPS at 2032 x 1920 resolution (1422 TV lines)
- Selectable H.264, MPEG-4 SP, MJPEG compressions with dual streaming
- Two-way audio
- iMicroSD / MicroSDHC card slot for local storage
- ExDR (Extreme Dynamic Range)
- 2D+3D Digital noise reduction
- Vandal proof and weatherproof IP66 rated casing
- Powered by PoE Class 3 / DC 12V
- Video Insight VMS license included



Technical Specifications

Camera

Image Sensor:	Aptina Progressive Scan CMOS
Sensor Size:	1/3.2"
Horizontal Resolution:	1422 TVL
Day & Night:	Yes
Color to B/W Switch:	ISP based, configurable
IR Sensitivity Range:	No
IR LED:	No
Electronic Shutter:	Manual mode: 1/25 - 1/2000 sec. (50Hz); 1/15 - 1/2000 sec. (60Hz) Manual mode: 1/25 - 1/2000 sec. (50Hz); 1/15 - 1/2000 sec. (60Hz)

Lens

Focal Length / Aperture:	Zoom, F3.3 - 12 mm / F1.4 - 2.9
Zoom Ratio:	3.6x optical
Iris:	P-Iris
Focus:	Auto focus
Mount Type:	Board Mount
Horizontal Viewing Angle:	77.22° - 22.62°
Viewing Angle Adjustment:	Pan: 0° - 360°; Tilt: 0° - 180°; Rotate: 0° - 360°

Video

Compression	MJPEG / MPEG-4 / H.264
Maximum Frame Rate: H.264 & MJPEG	8 FPS(2032 X 1920), FPS(1920 X 1080), 30 FPS(1280 X 720 HD 720p), FPS 640 x 480 (VGA)
Maximum Frame Rate vs. Resolution: MPEG-4 SP	5 FPS(2032 X 1920), 11 FPS(1920 X 1080), 25 FPS(1280 X 720 HD 720p), FPS 640 x 480 (VGA)
4 Cropped VGA Mode: (All Compressions)	FPS(640 x 480 VGA)

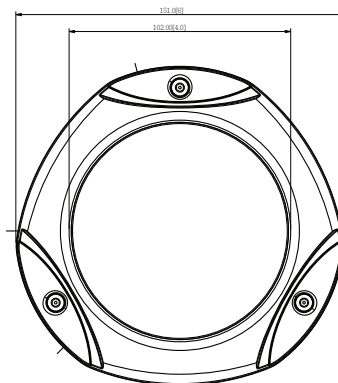
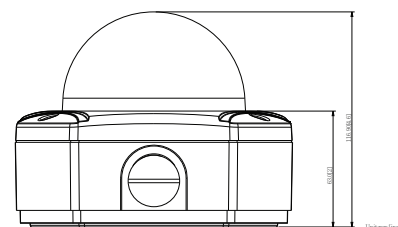

Technical Specifications

Bit Rate:	28 K bps - 6 Mbps (per stream)
Bit Rate Mode:	Constant, variable
Image Enhancement:	ExDR (Extreme Dynamic Range); White balance: automatic, hold and manual; Brightness; Saturation; Contrast; Sharpness; Automatic gain control; 2D+ 3D Digital noise reduction; Flickerless; Defogging
Privacy Mask:	4 Configurable regions
Text Overlay:	User defined text on video
Image Orientation:	Image flip and mirrors
Audio	
Compression:	8 KHz. Mono, PCM, 16 bit encoding
Audio In:	Terminal block
Audio Out:	Terminal block
Network	
Protocol & Service:	Bonjour, SNMP, UPnP, FTP, SMTP, IGMP, ARP, ICMP, NTP, DDNS, DNS, IPv6, RTSP, RTP, PPPoE, DHCP, HTTPS, HTTP, UDP, TCP
Ethernet Port:	1, ethernet (10/100 Base-T), RJ-45 connector
Security:	Password protection and watermark
Alarm	
Alarm Trigger	Video motion detection 3 regions in single view mode, 1 region each in 4 cropped VGA mode; External device through digital input
Interface	
Digital Input:	2, Terminal block
Digital Output:	2, Terminal block
Local Storage:	Micro SD / MicroSDHC memory card slot (card not included)
General	
Power Source / Consumption:	PoE Class 3 (IEEE802.3af) / 12.24W PoE Class 3 (IEEE802.3af) / 12.24W
Environmental Casing:	Weatherproof (IP66 rated); Transparent vandal proof dome cover, up to 1453.35 lbf
Mount Type:	Surface, Pendant, Wall, Corner, Pole, Flush
Operating Temperature:	-22° F ~ 122° F
Operating Humidity:	10% ~ 85% RH
Dimensions:	3.93" × 3.84" × 1.83"
Weight:	0.55 Lbs
Approvals:	Camera: CE, FCC, IP66

Overview

- 1/3.2" Progressive Scan CMOS
- 4 megapixel resolution
- Day and night function with mechanical IR cut filter
- Minimum illumination 0.05 lux at F1.4
- 18x Zoom
- Built-in f4.7-84.6 mm / f1.6 megapixel iris zoom lens
- 8 FPS at 2032 x 1920 resolution
- Selectable H.264, MPEG-4 SP, MJPEG compressions with dual streaming
- Serial port for external pan & tilt scanner
- 2D+3D Digital noise reduction
- Weatherproof IP66 rated casing
- Powered by PoE Class 3 / DC 12V
- Video Insight VMS license included



Technical Specifications

Camera

Image Sensor:	Progressive Scan CMOS
Sensor Size:	1/3.2" (4.5 x 3.4 mm)
Day/Night	Yes
Min. Illumination:	Color: 0.1 lux at F1.6 (30 IRE, 2400°K); B/W: 0 lux (IR LED on)
Color to B/W Switch:	ISP based, configurable
Mechanical IR Cut Filter:	Yes
IR Sensitivity Range:	700 - 1100 nm
Electronic Shutter:	Manual mode: 1/25 - 1/2000 sec. (50Hz); 1/15 - 1/2000 sec. (60Hz) Auto mode: 1 - 1/2000 sec.

Lens

Focal Length / Aperture:	Zoom, f4.7 - 84.6 mm / F1.6 - F2.8
Zoom Ratio:	18x optical
Zoom Speed:	2.63 sec (1x to 18x)
Iris:	DC Iris
Focus:	Auto focus
Mount Type:	Board mount
Horizontal Viewing Angle:	48.94° - 3.61°

Video

Compression:	MJPEG / MPEG-4 / H.264
Maximum Frame Rate: H.264 & MJPEG	8 FPS(2032 x 1920), 15 FPS(1920 x 1080 HD 1080p), 30 FPS(1280 x 720 HD 720p), 30 FPS (640 x 480 VGA)
Maximum Frame Rate vs. Resolution: MPEG-4 SP	8 FPS(2032 x 1920), 10 FPS(1920 x 1080 HD 1080p), 24 FPS(1280 x 720 HD 720p), 30 FPS (640 x 480 VGA)
4 Cropped VGA Mode: (All Compressions)	15 FPS(640 x 480 VGA)

Technical Specifications

Bit Rate Mode:	Constant, Variable
Image Enhancement:	SDR (Superior Dynamic Range); White balance: automatic, hold and manual; Brightness; Contrast; Automatic gain control; 2D+3D Digital noise reduction; Flickerless; Defogging
Privacy Mask:	4 configurable regions
Text Overlay:	User defined text on video
Image Orientation:	Image flip and mirror
Audio	
Compression:	8 kHz. Mono, PCM, 16 bit encoding
Audio In:	3.5mm Phone Jack
Audio Out:	TCP/IP, HTTP, DHCP, DNS, DDNS, RTP, RTSP, PPPoE, SMTP, NTP, SNMP, HTTPS, FTP, 802.1x, Qos (SIP, SRTP, IPv6 optional)
Network	
Protocol & Service:	TCP, UDP, HTTP, HTTPS, DHCP, PPPoE, RTP, RTSP, IPv6, DNS, DDNS, NTP, ICMP, ARP, IGMP, SMTP, FTP, UPnP, SNMP, Bonjour, Pelco-D
Ethernet Port:	1, Ethernet (10/100 Base-T), RJ-45 connector
Security:	IP address filtering; HTTPS encryption; Password protected user levels; IEEE 802.1X network access control
Alarm	
Alarm Trigger:	Video motion detection 3 regions in single view mode, External device through digital input
Interface	
Digital Input:	2, terminal block
Digital Output:	2, terminal block
Local Storage:	MicroSD / MicroSDHC memory card slot (card not included) DC 12V / 11.52 W (IR on)
General	
Power Source / Consumption:	PoE Class 3 (IEEE802.3af) / 9.12 W (IR on)
Environmental Casing:	Weatherproof (IP66 rated)
Operating Temperature:	-22° F - 149° F
Operating Humidity:	10% ~ 85% RH
Dimensions:	4.50" x 5.10" x 7.70"
Weight:	2.98 lb.

Overview

- 1 channel
- All channels D1 resolution, H.264 at 30FPS
- Dual Stream
- Video loop-outs
- Encoder-based motion detection
- De-interlaced images
- PTZ support
- 1 channel Audio in and out
- 1 Digital Input and 1 Output
- Video Insight VMS license included



Technical Specifications

Video/Audio Input	Video Compression:	H.264
	Video Input:	1-ch
	Video Input Interface:	BNC (1.0V p-p, 75Ω)
	Audio Compression:	OggVorbis, 16Kbps
	Audio Input:	1-ch
	Audio Input Interface:	BNC (2V p-p, 1kΩ)
	Voice Talk Input:	1, RCA (2.0V p-p, 1kΩ)
Video/Audio Output	Encode/Decode Resolution:	4CIF / DCIF / 2CIF / CIF / QCIF
	Frame Rate:	4CIF: 25(P) / 30(N) fps
	Stream Type:	Video / Video & Audio
	Support Dual Stream:	Yes
	Video Bit Rate:	32Kbps ~ 2Mbps, or user-defined (Max. 8Mbps)
	Audio Output:	1 Channel RCA (Linear Electrical Level, 600Ω)
	External Interface	Network Interface:
RS-232 Port:		1 RJ45 RS-232 Port
RS-485 Port:		1 (T+, T-)
Alarm Input:		1-ch
Alarm Output:		1-ch
General	Power Supply:	12 VDC
	Consumption:	≤12W
	Working Temperature:	14°F ~ +131°F
	Working Humidity:	10% ~ 90%
	Dimension (DxWxH):	4.72 x 2.76 x 1.77 in.
	Weight (without HDD):	≤1.1lbs

Overview

- 4 channel
- All channels D1 resolution, H.264 at 30FPS
- Dual Stream
- 4 video loop-outs
- Encoder-based motion detection
- De-interlaced images
- PTZ support
- 1 channel Audio in and out
- 4 Digital Input and 1 Output
- Video Insight VMS license included



Technical Specifications

Video/Audio Input	Video Compression:	H.264
	Video Input:	4-ch, BNC (1.0V p-p, 75Ω)
	Audio Compression:	OggVorbis
	Audio Input:	4-ch, BNC (1.0V p-p, 1 kΩ)
	Audio Input Interface:	BNC(2Vp-p, 1kΩ)
	Voice Talk Input:	1-ch, 3.5mm audio interface (2.0V p-p, 1 kΩ)
Video/Audio Output	Audio Output:	1-ch, 3.5mm audio interface (2.0V p-p, 1 kΩ)
	Encoding Resolution:	QCIF / CIF / 2CIF / 4CIF
	Frame Rate:	25 fps (P) / 30 fps (N)
	Video Bit Rate:	32 kbps ~ 2048 kbps, or user-defined (Max. 3 Mbps)
	Audio Bit Rate:	64 kbps
	Dual Stream:	Supported
	Stream Type:	Video / Video & Audio
External Interface	Network Interface:	1 RJ-45 10M / 100 Mbps self-adaptive UTP Ethernet interface
	Serial Interface:	1 RS-485 interface (PTZ control), 1 RS-232 interface
	Alarm In:	4
	Alarm Out:	2
General	Power Supply:	12 VDC power supply
	Consumption:	≤8W
	Working Temperature:	14°F ~ +131°F
	Working Humidity:	10% ~ 90%
	Dimensions (DxWxH):	7.89 x 5.35 x 1.65 in.
	Weight (without HDD):	≤4.41 lbs

Overview

- 8 channel 1U rackmount case
- All channels D1 resolution, H.264 at 30FPS
- Dual Stream
- 8 video loop-outs
- Encoder-based motion detection
- De-interlaced images
- PTZ support
- 1 channel Audio in and out
- 8 Digital Inputs and 4 Outputs
- Video Insight VMS license included



Technical Specifications

Video/Audio Input	Video Compression:	Standard H.264
	Video Input:	8-ch, BNC (1.0V p-p, 75Ω)
	Audio Compression:	OggVorbis
	Audio Input:	8-ch, BNC (2.0V p-p, 1 kΩ)
	Voice Talk Input:	1-ch, MIC connector
Video/Audio Output	Video Loop Out:	H.264 / MJPEG
	Audio Output:	1-ch, MIC connector (2.0V p-p, 1 kΩ)
	Recording Resolution:	QCIF / CIF / 2CIF / 4CIF
	Frame Rate:	QCIF / CIF / 2CIF / 4CIF; 25(P) / 30(N)
	Video Bit Rate:	32Kps ~ 2048Kbps, or user-defined (Max. 3Mbps)
	Dual Stream:	Supported
	Stream Type:	Video / Video & Audio
External Interface	Network Interface:	1 RJ-45 10 / 100 / 1000 Mbps self-adaptive UTP Ethernet interface
	Serial Interface:	1 RS-485, 1 RS-232 (DB9 Port)
	Alarm In:	16
	Alarm Out:	4
General	Chassis:	1U, 19-inch; Rear panel provides Reset button
	Power Supply:	100 ~ 240VAC, 6.3A, 50 ~ 60Hz
	Consumption:	≤40W (without HDD)
	Working Temperature:	10% ~ 90%
	Dimensions (DxWxH):	17.32 x 11.81 x 1.77 in.
	Weight (without HDD):	≤11.02 lbs

Overview

- 16 channel 1U rackmount case
- All channels D1 resolution, H.264 at 30FPS
- Dual Stream
- 16 video loop-outs
- Encoder-based motion detection
- De-interlaced images
- PTZ support
- 1 channel Audio in and out
- 16 Digital Inputs and 4 Outputs
- Video Insight VMS license included



Technical Specifications

Inputs:	16 BNC Inputs
Video Loop Out:	16 (VP16)
Audio Input:	16 (VP16a only)
Alarm Inputs:	16
Alarm Outputs:	4
Compression Type:	H.264
Resolutions:	D1, 2CIF, CIF, QCIF
FPS:	Each at 30 fps
PTZ Support:	RS 232, 485
Networking:	RJ45 10 / 100 / 1000 Mbps self-adaptive UTP Ethernet
Weight:	11 lbs
Dimensions (WxDxH):	17.32 x 16.81 x 1.77 in.
Temperature Range:	14°F ~ 131°F
Humidity:	10% - 90%
Power Inputs:	110 VAC, 60Hz, 6.3A
Power Usage:	40W

Overview

- 16 channel
- All channels D1 resolution, H.264 at 6FPS
- Encoder-based motion detection
- De-interlaced images
- 1 channel Audio in and out
- Video Insight VMS license included



Technical Specifications

Inputs:	16 BNC Inputs
Video Loop Out:	0
Audio Input:	1
Audio Output:	1
Alarm Inputs:	0
Alarm Outputs:	0
Compression Type:	H.264
Resolutions:	D1, 2CIF, CIF, QCIF
FPS:	Each channel at 6 fps
PTZ Support:	RS 485 (1 channel)
Networking:	RJ45 10 / 100 / 1000 Mbps self-adaptive UTP Ethernet
Weight:	5 lbs
Dimensions (WxDxH):	12.375" x 12.375" x 1.75"
Temperature Range:	14°F ~ 131°F
Humidity:	10% - 90%
Power Inputs:	110 VAC, 60Hz, 1.3A External power supply
Power Usage:	40W