

TIPS VENDOR AGREEMENT

Between VGI Technology, Inc and
(Company Name)

THE INTERLOCAL PURCHASING SYSTEM (TIPS), a Department of Texas Education Service Center Region 8 for **TIPS RFP 200203 Security Systems Products and Services**

General Information

The Vendor Agreement (“Agreement”) made and entered into by and between The Interlocal Purchasing System (hereinafter “TIPS”) a government cooperative purchasing program authorized by the Region 8 Education Service Center, having its principal place of business at 4845 US Hwy 271 North, Pittsburg, Texas 75686 and the TIPS Vendor. This Agreement consists of the provisions set forth below, including provisions of all attachments referenced herein. In the event of a conflict between the provisions set forth below and those contained in any attachment, the provisions set forth shall control unless otherwise agreed by the parties in writing and by signature and date on the attachment.

A Purchase Order (“PO”), Agreement or Contract is the TIPS Member’s approval providing the authority to proceed with the negotiated delivery order under the Agreement. Special terms and conditions as agreed between the Vendor and TIPS Member should be added as addendums to the Purchase Order, Agreement or Contract. Items such as certificate of insurance, bonding requirements, small or disadvantaged business goals are some, but not all, of the possible addendums.

Terms and Conditions

Freight

All quotes to Members shall provide a line item for cost for freight or shipping regardless if there is a charge or not. If no charge for freight or shipping, indicate by stating “No Charge”, “\$0”, “included in price” or other similar indication. Otherwise, all shipping, freight or delivery charges shall be passed through to the TIPS Member at cost with no markup and said charges shall be agreed by the TIPS Member unless alternative shipping terms are agreed by TIPS as a result of the proposal award.

Warranty Conditions

All new supplies equipment and services shall include ***manufacturer's minimum standard warranty*** unless otherwise agreed to in writing. Vendor shall be legally permitted to sell all products offered for sale to TIPS Members if the offering is included in the Request for Proposal (“RFP”) category. All goods proposed and sold shall be new unless clearly stated in writing.

Customer Support

The Vendor shall provide timely and accurate customer support for orders to TIPS Members as agreed by the Parties. Vendors shall respond to such requests within a commercially reasonable time after receipt of the request. If support and/or training is a line item sold or packaged with a sale, support shall be as agreed with the TIPS Member.

Agreements

Agreements for purchase will normally be put into effect by means of a purchase order(s) executed by authorized agents of the TIPS Member participating government entities, but other means of placing an order may be used at the Member's discretion.

Tax exempt status

Most TIPS Members are tax exempt and the related laws and/or regulations of the controlling jurisdiction(s) of the TIPS Member shall apply.

Assignments of Agreements

No assignment of this Agreement may be made without the prior notification of TIPS. Written approval of TIPS shall not be unreasonably withheld. Payment for delivered goods and services can only be made to the awarded Vendor, Vendor designated reseller or vendor assigned company.

Disclosures

- Vendor and TIPS affirm that he/she, or any authorized employees or agents, has not given, offered to give, nor intends to give at any time hereafter any economic opportunity, future employment, gift, loan, gratuity, special discount, trip, favor or service to a public servant in connection with this Agreement.
- Vendor shall attach, in writing, a complete description of any and all relationships that might be considered a conflict of interest in doing business with the TIPS program.
- The Vendor affirms that, to the best of his/her knowledge, the offer has been arrived at independently, and is submitted without collusion with anyone to obtain information or gain any favoritism that would in any way limit competition or give an unfair advantage over other vendors in the award of this Agreement.

Term and Renewal of Agreements

The Agreement with TIPS is for three (3) years with an option for renewal for an additional one (1) consecutive year if both parties agree. TIPS may or may not exercise the one-year extension beyond the base three-year term and whether or not to offer the extension is at the sole discretion of TIPS. The scheduled Agreement termination date shall be the last date of the month of the last month of the agreement's legal effect.

Example: *If the agreement is scheduled to end on May 23, the anniversary date of the award, it would actually be extended to May 31 in the last month of the last year the contract is active.*

Automatic Renewal Clauses Incorporated in Awarded Vendor Agreements with TIPS Members Resulting from the Solicitation and with the Vendor Named in this Agreement.

No Agreement for goods or services with a TIPS Member by the awarded vendor named in this Agreement that results from the solicitation award named in this Agreement, may incorporate an automatic renewal clause that exceeds month to month terms with which the TIPS Member must comply. All renewal terms incorporated in an Agreement by the vendor with the TIPS Member shall only be valid and enforceable when the vendor receives written confirmation by purchase order, executed Agreement or other written instruction issued by the TIPS Member for any renewal period. The purpose of this clause is to avoid a TIPS Member inadvertently renewing an Agreement during a period in which the governing body of the TIPS Member has not properly appropriated and budgeted the funds to satisfy the Agreement renewal. This term is not negotiable and any Agreement between a TIPS Member and a TIPS awarded vendor with an automatic renewal clause that conflicts with these terms is rendered void and unenforceable.

Shipments

The Vendor shall ship, deliver or provide ordered products or services within a commercially reasonable time after the receipt of the order from the TIPS Member. If a delay in said delivery is anticipated, the Vendor shall

notify TIPS Member as to why delivery is delayed and shall provide an estimated time for completion of the order. TIPS or the requesting entity may cancel the order if estimated delivery time is not acceptable or not as agreed by the parties.

Invoices

Each invoice or pay request shall include the TIPS Member's purchase order number or other identifying designation as provided in the order by the TIPS Member. If applicable, the shipment tracking number or pertinent information for verification of TIPS Member receipt shall be made available upon request.

Payments

The TIPS Member will make payments directly to the Vendor, the Vendor Assigned Dealer or as agreed by the Vendor and the TIPS Member after receiving invoice and in compliance with applicable payment statute(s), whichever is the greater time or as otherwise provided by an agreement of the parties.

Pricing

Price increases will be honored according to the terms of the solicitation. All pricing submitted to TIPS shall include the participation fee, as provided in the solicitation, to be remitted to TIPS by the Vendor. Vendor will not show adding the fee to the invoice presented to TIPS Member customer.

Participation Fees and Reporting of Sales to TIPS by Vendor

The Participation Fee that was published as part of the Solicitation and the fee published is the legally effective fee, along with any fee conditions stated in the Solicitation. Collection of the fees by TIPS is required under Texas Government Code §791.011 Et seq. Fees are due on all TIPS purchases reported by either Vendor or Member. Fees are due to TIPS upon payment by the Member to the Vendor, Reseller or Vendor Assigned Dealer. Vendor, Reseller or Vendor Assigned Dealer agrees to pay the participation fee to TIPS for all Agreement sales upon receipt of payment including partial payment, from the Member Entity or as otherwise agreed by TIPS in writing and signed by an authorized signatory of TIPS. Thus, when an awarded Vendor, Reseller or Vendor Assigned Dealer receives any amount of payment, even partial payment, for a TIPS sale, the legally effective fee for that amount is due to TIPS from the Vendor.

Reporting of Sales to TIPS by Vendor

Vendor is required to report all sales under the TIPS contract to TIPS. If the TIPS Member entity requesting a price from the awarded Vendor requests the TIPS contract, Vendor must include the TIPS Contract number on any communications with the TIPS Member entity. To report sales, the Vendor must login to the TIPS Vendor Portal online at https://www.tips-usa.com/vendors_form.cfm and click on the PO's and Payments tab. Pages 3-7 of the [Vendor Portal User Guide](#) will walk you through the process of reporting sales to TIPS. Please refer to the TIPS [Accounting FAQ's](#) for more information about reporting sales and if you have further questions, contact the Accounting Team at accounting@tips-usa.com. The Vendor or vendor assigned dealers are responsible for keeping record of all sales that go through the TIPS Agreement and submitting same to TIPS. Failure to render the participation fee to TIPS shall constitute a breach of this agreement with our parent governmental entity, Texas Education Service Center Region 8, as established by the Texas legislature and shall be grounds for termination of this agreement and any other agreement held with TIPS and possible legal action. Any overpayment of participation fees to TIPS by a Vendor will be refunded to the Vendor within ninety (90) days of receipt of notification if TIPS receives written notification of the overpayment not later than the expiration of six (6) months from the date of overpayment and TIPS determines that the amount was not legally due to TIPS pursuant to this agreement and applicable law. It is the Vendor's responsibility to identify which sales are TIPS Agreement sales and pay the correct participation fee due for TIPS Agreement sales. Any notification of overpayment received by TIPS after the expiration of six (6) months from the date of overpayment will be non-refundable. Region 8 ESC and TIPS reserve the right to extend the six (6) month deadline to notify if approved by the Region 8 ESC Board of Directors. TIPS reserves all rights under the law to collect the fees due. Please contact TIPS at tips@tips-usa.com or call (866) 839-8477 if you have questions about paying fees.

Indemnity

The Vendor agrees to indemnify and hold harmless and defend TIPS, TIPS Member(s), officers and employees from and against all claims and suits by third parties for damages, injuries to persons (including death), property damages, losses, and expenses including court costs and reasonable attorney's fees, arising out of, or resulting from, Vendor's performance under this Agreement, including all such causes of action based upon common, constitutional, or statutory law, or based in whole or in part, upon allegations of negligent or intentional acts on the part of the Vendor, its officers, employees, agents, subcontractors, licensees, or invitees. Parties found liable shall pay their proportionate share of damages as agreed by the parties or as ordered by a court of competent jurisdiction over the case. **NO LIMITATION OF LIABILITY FOR DAMAGES FOR PERSONAL INJURY OR PROPERTY DAMAGE ARE PERMITTED OR AGREED BY TIPS/ESC REGION 8.** Per Texas Education Code §44.032(f), and pursuant to its requirements only, reasonable Attorney's fees are recoverable by the prevailing party in any dispute resulting in litigation.

State of Texas Franchise Tax

By signature hereon, the Vendor hereby certifies that he/she is not currently delinquent in the payment of any franchise taxes owed the State of Texas under Chapter 171, Tax Code.

Miscellaneous

The Vendor acknowledges and agrees that continued participation in TIPS is subject to TIPS sole discretion and that any Vendor may be removed from the participation in the Program at any time with or without cause. Nothing in the Agreement or in any other communication between TIPS and the Vendor may be construed as a guarantee that TIPS or TIPS Members will submit any orders at any time. TIPS reserves the right to request additional proposals for items or services already on Agreement at any time.

Purchase Order Pricing/Product Deviation

If a deviation of pricing/product on a Purchase Order or contract modification occurs between the Vendor and the TIPS Member, TIPS must be notified within five (5) business days of receipt of change order.

Termination for Convenience of TIPS Agreement Only

TIPS reserves the right to terminate this agreement for cause or no cause for convenience with a thirty (30) days prior written notice. Termination for convenience is conditionally required under Federal Regulations 2 CFR part 200 if the customer is using federal funds for the procurement. All purchase orders presented to the Vendor, but not fulfilled by the Vendor, by a TIPS Member prior to the actual termination of this agreement shall be honored at the option of the TIPS Member. The awarded Vendor may terminate the agreement with ninety (90) days prior written notice to TIPS 4845 US Hwy North, Pittsburg, Texas 75686. The vendor will be paid for goods and services delivered prior to the termination provided that the goods and services were delivered in accordance with the terms and conditions of the terminated agreement. This termination clause does not affect the sales agreements executed by the Vendor and the TIPS Member customer pursuant to this agreement. TIPS Members may negotiate a termination for convenience clause that meets the needs of the transaction based on applicable factors, such as funding sources or other needs.

TIPS Member Purchasing Procedures

Usually, purchase orders or their equal are issued by participating TIPS Member to the awarded vendor and should indicate on the order that the purchase is per the applicable TIPS Agreement Number. Orders are typically emailed to TIPS at tipspo@tips-usa.com.

- Awarded Vendor delivers goods/services directly to the participating member.
- Awarded Vendor invoices the participating TIPS Member directly.
- Awarded Vendor receives payment directly from the participating member.
- Fees are due to TIPS upon payment by the Member to the Vendor. Vendor agrees to pay the participation fee to TIPS for all Agreement sales upon receipt of payment including partial payment, from the Member Entity or as otherwise agreed by TIPS in writing and signed by an authorized

signatory of TIPS.

Licenses

Awarded Vendor shall maintain, in current status, all federal, state and local licenses, bonds and permits required for the operation of the business conducted by awarded Vendor. Awarded Vendor shall remain reasonably fully informed of and in compliance with all ordinances and regulations pertaining to the lawful provision of goods or services under the Agreement. TIPS and TIPS Members reserves the right to stop work and/or cancel an order or terminate this or any other sales Agreement of any awarded Vendor whose license(s) required for performance under this Agreement have expired, lapsed, are suspended or terminated subject to a 30-day cure period unless prohibited by applicable statute or regulation.

Novation

If awarded Vendor sells or transfers all assets, rights or the entire portion of the assets or rights required to perform this Agreement, a successor in interest must guarantee to perform all obligations under this Agreement. A simple change of name agreement will not change the Agreement obligations of awarded vendor. TIPS will consider Contract Assignments on a case by case basis. TIPS must be notified within five (5) business days of the transfer of assets or rights.

Site Requirements (*only when applicable to service or job*)

Cleanup: When performing work on site at a TIPS Member's property, awarded Vendor shall clean up and remove all debris and rubbish resulting from their work as required or directed by TIPS Member or as agreed by the parties. Upon completion of work, the premises shall be left in good repair and an orderly, neat, clean and unobstructed condition.

Preparation: Awarded Vendor shall not begin a project for which TIPS Member has not prepared the site, unless awarded Vendor does the preparation work at no cost, or until TIPS Member includes the cost of site preparation in a purchase order. Site preparation includes, but is not limited to: moving furniture, installing wiring for networks or power, and similar pre-installation requirements.

Registered sex offender restrictions: For work to be performed at schools, awarded Vendor agrees that no employee of a subcontractor who has been adjudicated to be a registered sex offender will perform work at any time when students are, or reasonably expected to be, present unless otherwise agreed by the TIPS Member. Awarded Vendor agrees that a violation of this condition shall be considered a material breach and may result in the cancellation of the purchase order at the TIPS Member's discretion. Awarded Vendor must identify any additional costs associated with compliance of this term. If no costs are specified, compliance with this term will be provided at no additional charge. **Safety measures:** Awarded Vendor shall take all reasonable precautions for the safety of employees on the worksite, and shall erect and properly maintain all necessary safeguards for protection of workers and the public. Awarded Vendor shall post warning signs against all hazards created by the operation and work in progress. Proper precautions shall be taken pursuant to state law and standard practices to protect workers, general public and existing structures from injury or damage.

Safety Measures

Awarded Vendor shall take all reasonable precautions for the safety of employees on the worksite, and shall erect and properly maintain all necessary safeguards for protection of workers and the public. Awarded vendor shall post warning signs against all hazards created by the operation and work in progress. Proper precautions shall be taken pursuant to state law and standard practices to protect workers, general public and existing structures from injury or damage.

Smoking

Persons working under Agreement shall adhere to the TIPS Member's or local smoking statutes, codes or policies.

Marketing

Awarded Vendor agrees to allow TIPS to use their name and logo within TIPS website, marketing materials and advertisement subject to any reasonable restrictions provided to TIPS in the Proposal to the Solicitation. The Vendor may submit an acceptable use directive for Vendor's names and logos with which TIPS agrees to comply. Any use of TIPS name and logo or any form of publicity, inclusive of press release, regarding this Agreement by awarded vendor must have prior approval from TIPS which will not be unreasonably withheld. Request may be made by email to TIPS@TIPS-USA.COM.

Supplemental Agreements

The TIPS Member entity participating in the TIPS Agreement and awarded Vendor may enter into a separate Supplemental Agreement or contract to further define the level of service requirements over and above the minimum defined in this Agreement such as but not limited to, invoice requirements, ordering requirements, specialized delivery, etc. Any Supplemental Agreement or contract developed as a result of this Agreement is exclusively between the TIPS Member entity customer and the Vendor. TIPS, its agents, TIPS Members and employees not a party to the Supplemental Agreement with the TIPS Member customer, shall not be made party to any claim for breach of such agreement unless named and agreed by the Party in question in writing in the agreement. If a Vendor submitting a Proposal requires TIPS and/or TIPS Member to sign an additional agreement, those agreements shall comply with the award made by TIPS to the Vendor. Supplemental Vendor's Agreement documents may not become part of TIPS' Agreement with Vendor unless and until an authorized representative of TIPS reviews and approves it. TIPS review and approval may be at any time during the life of this Vendor Agreement. TIPS permits TIPS Members to negotiate additional terms and conditions with the Vendor for the provision of goods or services under the Vendor's TIPS Agreement so long as they do not materially conflict with this Agreement.

Survival Clause

All applicable sales, leases, Supplemental Agreements, contracts, software license agreements, warranties or service agreements that were entered into between Vendor and TIPS or the TIPS Member Customer under the terms and conditions of this Agreement shall survive the expiration or termination of this Agreement. All Orders, Purchase Orders issued or contracts executed by TIPS or a TIPS Member and accepted by the Vendor prior to the expiration or termination of this agreement, shall survive expiration or termination of the Agreement, subject to previously agreed terms and conditions agreed by the parties or as otherwise specified herein relating to termination of this agreement.

Legal obligations

It is the responding Vendor's responsibility to be aware of and comply with all local, state and federal laws governing the sale of products/services identified in the applicable Solicitation that resulted in this Vendor Agreement and any awarded Agreement thereof. Applicable laws and regulations must be followed even if not specifically identified herein.

Audit rights

Due to transparency statutes and public accountability requirements of TIPS and TIPS Members', the awarded Vendor shall, at their sole expense, maintain appropriate due diligence of all purchases made by TIPS Member that utilizes this Agreement. TIPS and Region 8 ESC each reserve the right to audit the accounting of TIPS related purchases for a period of three (3) years from the time such purchases are made. This audit right shall survive termination of this Agreement for a period of one (1) year from the effective date of termination. In order to ensure and confirm compliance with this agreement, TIPS shall have authority to conduct audits of Awarded Vendor's pricing or TIPS transaction documentation with TIPS Members with 30 days' notice unless the audit is ordered by a Court Order or by a Government Agency with authority to do so without notice. Notwithstanding the foregoing, in the event that TIPS is made aware of any pricing being offered to eligible entities that is materially inconsistent with the pricing under this agreement, TIPS shall have the ability to conduct the audit internally or may engage a third- party auditing firm to investigate any possible non-

compliant conduct or may terminate the Agreement according to the terms of this Agreement. In the event of an audit, the requested materials shall be reasonably provided in the time, format and at the location acceptable to Region 8 ESC or TIPS. TIPS agrees not to perform a random audit the TIPS transaction documentation more than once per calendar year, but reserves the right to audit for just cause or as required by any governmental agency or court with regulatory authority over TIPS or the TIPS Member.

Force Majeure

If by reason of Force Majeure, either party hereto shall be rendered unable wholly or in part to carry out its obligations under this Agreement then such party shall give notice and full particulars of Force Majeure in writing to the other party within a reasonable time after occurrence of the event or cause relied upon, and the obligation of the party giving such notice, so far as it is affected by such Force Majeure, shall be suspended during the continuance of the inability then claimed, except as hereinafter provided, but for no longer period, and such party shall endeavor to remove or overcome such inability with all reasonable dispatch.

Choice of Law

The Agreement between the Vendor and TIPS/ESC Region 8 and any addenda or other additions resulting from this procurement process, however described, shall be governed by, construed and enforced in accordance with the laws of the State of Texas, regardless of any conflict of laws principles.

Venue, Jurisdiction and Service of Process

Any Proceeding arising out of or relating to this procurement process or any contract issued by TIPS resulting from or any contemplated transaction shall be brought in a court of competent jurisdiction in Camp County, Texas and each of the parties irrevocably submits to the exclusive jurisdiction of said court in any such proceeding, waives any objection it may now or hereafter have to venue or to convenience of forum, agrees that all claims in respect of the Proceeding shall be heard and determined only in any such court, and agrees not to bring any proceeding arising out of or relating to this procurement process or any contract resulting from or any contemplated transaction in any other court. The parties agree that either or both of them may file a copy of this paragraph with any court as written evidence of the knowing, voluntary and freely bargained for agreement between the parties irrevocably to waive any objections to venue or to convenience of forum. Process in any Proceeding referred to in the first sentence of this Section may be served on any party anywhere in the world. Venue for any dispute resolution process, other than litigation, between TIPS and the Vendor shall be located in Camp or Titus County, Texas.

Project Delivery Order Procedures

The TIPS Member having approved and signed an interlocal agreement, or other TIPS Membership document, may make a request of the awarded Vendor under this Agreement when the TIPS Member desires goods or services awarded to the Vendor. Notification may occur via phone, the web, courier, email, fax, or in person. Upon notification of a pending request, the awarded Vendor shall acknowledge the TIPS Member's request as soon as possible, but must make contact with the TIPS Member within two working days.

Status of TIPS Members as Related to This Agreement

TIPS Members stand in the place of TIPS as related to this agreement and have the same access to the proposal information and all related documents. TIPS Members have all the same rights under the awarded Agreement as TIPS.

Vendor's Resellers as Related to This Agreement

Vendor's Named Resellers ("Resellers") under this Agreement shall comply with all terms and conditions of this agreement and all addenda or incorporated documents. All actions related to sales by Authorized Vendor's Resellers under this Agreement are the responsibility of the awarded Vendor. If Resellers fail to report sales to TIPS under your Agreement, the awarded Vendor is responsible for their contractual failures and shall be billed for the fees. The awarded Vendor may then recover the fees from their named reseller.

Support Requirements

If there is a dispute between the awarded Vendor and TIPS Member, TIPS or its representatives may, at TIPS sole discretion, assist in conflict resolution if requested by either party. TIPS, or its representatives, reserves the right to inspect any project and audit the awarded Vendor’s TIPS project files, documentation and correspondence related to the requesting TIPS Member’s order. If there are confidentiality requirements by either party, TIPS shall comply to the extent permitted by law.

Incorporation of Solicitation

The TIPS Solicitation which resulted in this Vendor Agreement, whether a Request for Proposals, the Request for Competitive Sealed Proposals or Request for Qualifications solicitation, or other, the Vendor’s response to same and all associated documents and forms made part of the solicitation process, including any addenda, are hereby incorporated by reference into this Agreement as if copied verbatim.

SECTION HEADERS OR TITLES

THE SECTION HEADERS OR TITLES WITHIN THIS DOCUMENT ARE MERELY GUIDES FOR CONVENIENCE AND ARE NOT FOR CLASSIFICATION OR LIMITING OF THE RESPONSIBILITIES OF THE PARTIES TO THIS DOCUMENT.

STATUTORY REQUIREMENTS

Texas governmental entities are prohibited from doing business with companies that fail to certify to this condition as required by Texas Government Code Sec. 2270.

By executing this agreement, you certify that you are authorized to bind the undersigned Vendor and that your company (1) does not boycott Israel; and (2) will not boycott Israel during the term of the Agreement.

You certify that your company is not listed on and does not and will not do business with companies that are on the Texas Comptroller of Public Accounts list of Designated Foreign Terrorists Organizations per Texas Gov't Code 2270.0153 found at <https://comptroller.texas.gov/purchasing/docs/foreign-terrorist.pdf>

You certify that if the certified statements above become untrue at any time during the life of this Agreement that the Vendor will notify TIPS within three (3) business day of the change by a letter on Vendor’s letterhead from and signed by an authorized representative of the Vendor stating the non-compliance decision and the TIPS Agreement number and description at:

Attention: General Counsel
ESC Region 8/The Interlocal Purchasing System (TIPS)
4845 Highway 271 North
Pittsburg, TX,75686
And by an email sent to bids@tips-usa.com

Insurance Requirements

The undersigned Vendor agrees to maintain the below minimum insurance requirements for TIPS Contract Holders:

General Liability	\$1,000,000 each Occurrence/ Aggregate
Automobile Liability	\$300,000 Includes owned, hired & non-owned
Workers' Compensation	Statutory limits for the jurisdiction in which the Vendor performs under this Agreement.
Umbrella Liability	\$1,000,000

When the Vendor or its subcontractors are liable for any damages or claims, the Vendor's policy, when the Vendor is responsible for the claim, must be primary over any other valid and collectible insurance carried by the Member. Any immunity available to TIPS or TIPS Members shall not be used as a defense by the contractor's insurance policy. The coverages and limits are to be considered minimum requirements and in no way limit the liability of the Vendor(s). Insurance shall be written by a carrier with an A-; VII or better rating in accordance with current A.M. Best Key Rating Guide. Only deductibles applicable to property damage are acceptable, unless proof of retention funds to cover said deductibles is provided. "Claims made" policies will not be accepted. Vendor's required minimum coverage shall not be suspended, voided, cancelled, non-renewed or reduced in coverage or in limits unless replaced by a policy that provides the minimum required coverage except after thirty (30) days prior written notice by certified mail, return receipt requested has been given to TIPS or the TIPS Member if a project or pending delivery of an order is ongoing. Upon request, certified copies of all insurance policies shall be furnished to the TIPS or the TIPS Member.

Special Terms and Conditions

- **Orders:** All Vendor orders received from TIPS Members must be emailed to TIPS at tipspo@tips-usa.com. Should a TIPS Member send an order directly to the Vendor, it is the Vendor's responsibility to forward a copy of the order to TIPS at the email above within 3 business days and confirm its receipt with TIPS.
- **Vendor Encouraging Members to bypass TIPS agreement:** Encouraging TIPS Members to purchase directly from the Vendor or through another agreement, when the Member has requested using the TIPS cooperative Agreement or price, and thereby bypassing the TIPS Agreement is a violation of the terms and conditions of this Agreement and will result in removal of the Vendor from the TIPS Program.
- **Order Confirmation:** All TIPS Member Agreement orders are approved daily by TIPS and sent to the Vendor. The Vendor should confirm receipt of orders to the TIPS Member (customer) within 3 business days.
- **Vendor custom website for TIPS:** If Vendor is hosting a custom TIPS website, updated pricing when effective. TIPS shall be notified when prices change in accordance with the award.
- **Back Ordered Products:** If product is not expected to ship within the time provided to the TIPS Member by the Vendor, the Member is to be notified within 3 business days and appropriate action taken based on customer request.

The TIPS Vendor Agreement Signature Page is inserted here.

TIPS Vendor Agreement Signature Form

RFP 200203 Security Systems Products and Services

Company Name VGI Technology, Inc.

Address 3321 Foster St

City San Angelo State Tx Zip 76903

Phone 325-223-3000 Fax N/A

Email of Authorized Representative wwilliams@vgitechnology.com

Name of Authorized Representative Wade Williams

Title Sr Security Applications Specialist

Signature of Authorized Representative *Wade Williams*

Date 3/10/2020

TIPS Authorized Representative Name Meredith Barton

Title Chief Operating Officer

TIPS Authorized Representative Signature *Meredith Barton*

Approved by ESC Region 8 *David Wayne Fitts*

Date 4/23/2020

NOTICE TO MEMBERS REGARDING ATTRIBUTE RESPONSES

TIPS VENDORS RESPOND TO ATTRIBUTE QUESTIONS AS PART OF TIPS COMPETITIVE SOLICITATION PROCESS. THE VENDOR'S RESPONSES TO ATTRIBUTE QUESTIONS ARE INCLUDED HEREIN AS "SUPPLIER RESPONSE." PLEASE BE ADVISED THAT DEVIATIONS, IF ANY, IN VENDOR'S RESPONSE TO ATTRIBUTE QUESTIONS MAY NOT REFLECT VENDOR'S FINAL ATTRIBUTE RESPONSE, WHICH IS SUBJECT TO NEGOTIATIONS PRIOR TO AWARD. PLEASE CONTACT THE TIPS OFFICE AT 866-839-8477 WITH QUESTIONS OR CONCERNS REGARDING VENDOR ATTRIBUTE RESPONSE DEVIATIONS. PLEASE KEEP IN MIND THAT TIPS DOES NOT PROVIDE LEGAL COUNSEL TO MEMBERS. TIPS RECOMMENDS THAT YOU CONSULT YOUR LEGAL COUNSEL WHEN EXECUTING CONTRACTS WITH OR MAKING PURCHASES FROM TIPS VENDORS.



200203 Addendum 2 VGI Technology Supplier Response

Event Information

Number: 200203 Addendum 2
Title: Security Systems Products and Services
Type: Request for Proposal
Issue Date: 2/6/2020
Deadline: 3/30/2020 03:00 PM (CT)

Contact Information

Contact: Kristie Collins
Address: Region 8 Education Service Center
4845 US Highway 271 North
Pittsburg, TX 75686
Phone: +1 (866) 839-8477
Fax: +1 (866) 839-8472
Email: bids@tips-usa.com

VGI Technology Information

Contact: Wade Williams
Address: 3321 Foster St
San Angelo
San Angelo, TX 76903
Phone: (325) 223-3000 x3017
Email: wwilliams@vgitechnology.com

By submitting your response, you certify that you are authorized to represent and bind your company.

Wade Williams

Signature

Submitted at 3/16/2020 1:26:41 PM

wwilliams@vgitechnology.com

Email

Requested Attachments

Vendor Agreement

200203_Vendor_Agreement (1).pdf

The vendor must download the Vendor Agreement from the attachment tab, fill in the requested information and upload the completed agreement.
DO NOT UPLOAD encrypted or password protected files.

Agreement Signature Form

200203_Agreement_Signature_Form.pdf

If you have not taken exception or deviation to the agreement language in the solicitation attributes, download the AGREEMENT SIGNATURE FORM from the "ATTACHMENTS" tab. This PDF document is a fillable form. Download the document to your computer, fill in the requested company information, print the file, SIGN the form, SCAN the completed and signed AGREEMENT SIGNATURE FORM, and upload here.

If you have taken exception to any of the agreement language and noted the exception in the deviations section of the attributes for the agreement, complete the AGREEMENT SIGNATURE FORM, but DO NOT SIGN until those deviations have been negotiated and resolved with TIPS management. Upload the unsigned form here, because this is a required document.

Pricing Spreadsheet #1

Pricing 1.xls

The vendor must download the PRICING SPREADSHEET SHEET from the attachment tab, fill in the requested information and upload the completed spreadsheet.
DO NOT UPLOAD encrypted or password protected files.

Pricing Spreadsheet #2

200105_Pricing_form_2.xlsx

The vendor must download the PRICING SPREADSHEET SHEET from the attachment tab, fill in the requested information and upload the completed spreadsheet.
DO NOT UPLOAD encrypted or password protected files.

References

References 2020.pdf

The vendor must download the References spreadsheet from the attachment tab, fill in the requested information and upload the completed spreadsheet. DO NOT UPLOAD encrypted or password protected files.

Proposed Goods and Services

Goods and Services 2020.pdf

Please upload one or more documents or sheets describing your offerings, line cards, catalogs, links to offerings OR list links to your offerings that illustrate the catalog of proposed lines of goods and or services you carry and offer under this proposal. It does not have to be exhaustive but should, at a minimum tell us what you are offering. It could be as simple as a sheet with your link to your online catalog of goods and services.

Resellers/Dealers - COMPLETE AND UPLOAD ONLY IF YOU HAVE RESELLER OF YOUR GOODS OR SERVICES PROPOSED *No response*

If the PROPOSING vendor has resellers that will be selling for the vendor UNDER this contract, the vendor must download the Resellers/Dealers spreadsheet from the attachment tab, fill in the requested information and upload the completed spreadsheet.
DO NOT UPLOAD encrypted or password protected files.

D/M/WBE Certification OPTIONAL *No response*

D/M/WBE Certification documentation may be scanned and uploaded if you desire to claim your status as one of the identified enterprises. (Disadvantaged Business Enterprise, Minority Business Enterprise and/or Woman Business Enterprise) If vendor has more than one certification scan into one document. (PDF Format ONLY)
DO NOT UPLOAD encrypted or password protected files.

Warranty *No response*

Warranty information (if applicable) must be scanned and uploaded. (PDF Format ONLY)
DO NOT UPLOAD encrypted or password protected files.

Supplementary *No response*

Supplementary information may be scanned and uploaded. (Company information, brochures, catalogs, etc.) (PDF Format ONLY)
DO NOT UPLOAD encrypted or password protected files.

All Other Certificates *No response*

All Other Certificates (if applicable) must be scanned and uploaded. If vendor has more than one other certification scan into one document. (PDF Format ONLY)
DO NOT UPLOAD encrypted or password protected files.

Logo and Other Company Marks *No response*

If you desire, please upload your company logo to be added to your individual profile page on the TIPS website. If any particular specifications are required for use of your company logo, please upload that information under the Supplementary section or another non-required section under the "Response Attachment" tab. Preferred Logo Format: 300 x 225 px - .png, .eps, .jpeg preferred

Conflict of Interest Form CIQ- ONLY REQUIRED IF A CONFLICT EXISTS PER THE INSTRUCTIONS *No response*

ONLY REQUIRED IF A CONFLICT EXISTS PER THE INSTRUCTIONS
Conflict of Interest Form for Vendors that are required to submit the form. The Conflict of Interest Form is included in the Base documents or can be found at <https://www.tips-usa.com/assets/documents/docs/CIQ.pdf>.

Certificate of Corporate Offerer - COMPLETE ONLY IF OFFERER IS A CORPORATION *No response*

COMPLETE AND UPLOAD FORM IN ATTACHMENTS SECTION ONLY IF OFFERER IS A CORPORATION

Disclosure of Lobbying Activities Standard Form LLL *No response*

ONLY IF you answered "I HAVE Lobbied per above" to attribute #66, please download and complete and upload the Standard Form-LLL, "disclosure Form to Report Lobbying," in the Response attachments section.

Confidentiality Form *Confidential Form 2020.pdf*

REQUIRED CONFIDENTIALITY FORM. Complete the form according to your company requirements, make any desired attachments and upload to the appropriate section under "Response Attachments" THIS FORM DETERMINES HOW ESC8/TIPS RESPONDS TO LEGAL PUBLIC INFORMATION REQUESTS.

Bid Attributes

1	Yes - No Disadvantaged/Minority/Women Business Enterprise - D/M/WBE (Required by some participating governmental entities) Vendor certifies that their firm is a D/M/WBE? Vendor must upload proof of certification to the "Response Attachments" D/M/WBE CERTIFICATES section. <input type="text" value="NO"/>
----------	--

2	Yes - No Historically Underutilized Business - HUB (Required by some participating governmental entities) Vendor certifies that their firm is a HUB as defined by the State of Texas at https://comptroller.texas.gov/purchasing/vendor/hub/ or in a HUBZone as defined by the US Small Business Administration at https://www.sba.gov/offices/headquarters/ohp Proof of one or both may be submitted. Vendor must upload proof of certification to the "Response Attachments" HUB CERTIFICATES section. <input type="text" value="No"/>
----------	--

3	Yes - No The Vendor can provide services and/or products to all 50 US States? <input type="text" value="No"/>
----------	--

4	States Served: If answer is NO to question #3, please list which states can be served. (Example: AR, OK, TX) <input type="text" value="No response"/>
----------	--

5	Company and/or Product Description: This information will appear on the TIPS website in the company profile section, if awarded a TIPS contract. (Limit 750 characters.) <input type="text" value="VGI specializes in IP Solutions (Security Camera Systems & Access Control) as well as providing Commercial & Residential Intrusion Detection Solutions."/>
----------	--

6	Primary Contact Name Primary Contact Name <input type="text" value="WADE WILLIAMS"/>
----------	---

7	Primary Contact Title Primary Contact Title <input type="text" value="Sr Security Applications Specialist"/>
----------	---

8	Primary Contact Email Primary Contact Email <input type="text" value="wwilliams@vgitechnology.com"/>
----------	---

9	Primary Contact Phone Enter 10 digit phone number. (No dashes or extensions) Example: 8668398477 <input type="text" value="3252233017"/>
----------	--

10	Primary Contact Fax Enter 10 digit phone number. (No dashes or extensions) Example: 8668398477 <input type="text" value="No response"/>
-----------	---

11	Primary Contact Mobile Enter 10 digit phone number. (No dashes or extensions) Example: 8668398477 <input type="text" value="No response"/>
-----------	--

1 2	Secondary Contact Name Secondary Contact Name Zack Watson
1 3	Secondary Contact Title Secondary Contact Title Director of Security
1 4	Secondary Contact Email Secondary Contact Email zwatson@vgitechnology.com
1 5	Secondary Contact Phone Enter 10 digit phone number. (No dashes or extensions) Example: 8668398477 3252233003
1 6	Secondary Contact Fax Enter 10 digit phone number. (No dashes or extensions) Example: 8668398477 No response
1 7	Secondary Contact Mobile Enter 10 digit phone number. (No dashes or extensions) Example: 8668398477 No response
1 8	Admin Fee Contact Name Admin Fee Contact Name. This person is responsible for paying the admin fee to TIPS. Kim Collins
1 9	Admin Fee Contact Email Admin Fee Contact Email kcollins@vgitechnology.com
2 0	Admin Fee Contact Phone Enter 10 digit phone number. (No dashes or extensions) Example: 8668398477 3252233000
2 1	Purchase Order Contact Name Purchase Order Contact Name. This person is responsible for receiving Purchase Orders from TIPS. Wade Williams
2 2	Purchase Order Contact Email Purchase Order Contact Email wwilliams@vgitechnology.com

23	Purchase Order Contact Phone Enter 10 digit phone number. (No dashes or extensions) Example: 8668398477 <input type="text" value="3252233017"/>
-----------	---

24	Company Website Company Website (Format - www.company.com) <input type="text" value="No response"/>
-----------	--

25	Federal ID Number: Federal ID Number also known as the Employer Identification Number. (Format - 12-3456789) <input type="text" value="No response"/>
-----------	--

26	Primary Address Primary Address <input type="text" value="3550 S BRYANT BLVD"/>
-----------	--

27	Primary Address City Primary Address City <input type="text" value="SAN ANGELO"/>
-----------	--

28	Primary Address State Primary Address State (2 Digit Abbreviation) <input type="text" value="Texas"/>
-----------	--

29	Primary Address Zip Primary Address Zip <input type="text" value="76903-9310"/>
-----------	--

30	Search Words: Please list search words to be posted in the TIPS database about your company that TIPS website users might search. Words may be product names, manufacturers, or other words associated with the category of award. YOU MAY NOT LIST NON-CATEGORY ITEMS. (Limit 500 words) (Format: product, paper, construction, manufacturer name, etc.) <input type="text" value="Security, Cameras, Access Control, Intrusion"/>
-----------	--

31	Do you want TIPS Members to be able to spend Federal grant funds with you if awarded? Is it your intent to be able to sell to our members regardless of the fund source, whether it be local, state or federal? Most of our members receive Federal Government grants and they make up a significant portion of their budgets. The Members need to know if your company is willing to sell to them when they spend federal budget funds on their purchase. There are attributes that follow that include provisions from the federal regulations in 2 CFR part 200. Your answers will determine if your award will be designated as Federal or Education Department General Administrative Regulations (EDGAR) compliant. Do you want TIPS Members to be able to spend Federal grant funds with you if awarded and is it your intent to be able to sell to TIPS Members regardless of the fund source, whether it be local, state or federal? <input type="text" value="Yes"/>
-----------	--

3 **Yes - No**

2

Certification of Residency (Required by the State of Texas) The vendor's ultimate parent company or majority owner:

(A) has its principal place of business in Texas;

OR

(B) employs at least 500 persons in Texas?

This question is required as a data gathering function for information to our members making purchases with awarded vendors. It does not affect scoring with TIPS.

3 **Company Residence (City)**

3

Vendor's principal place of business is in the city of?

3 **Company Residence (State)**

4

Vendor's principal place of business is in the state of?

3 **Discount Offered - CAUTION READ CAREFULLY BECAUSE VENDORS FREQUENTLY MAKE MISTAKES ON THIS ATTRIBUTE QUESTION**

5

Remember this is a MINIMUM discount percentage. So, be sure that the discount percentage inserted here can be applied to ANY OFFERING OF GOODS OR SERVICES THROUGHOUT THE LIFE OF THE CONTRACT

CAUTION: BE CERTAIN YOU CAN HONOR THIS MINIMUM DISCOUNT PERCENTAGE ON ANY OFFERED SERVICE OR GOOD NOW OR DURING THE LIFE OF THE CONTRACT.

What is the MINIMUM percentage discount off of any item or service you offer to TIPS Members that is in your regular catalog (as defined in the solicitation specifications document), website, store or shelf pricing or when adding new goods or services to your offerings during the life of the contract? The resulting price of any goods or services Catalog list prices after this discount is applied is a ceiling on your pricing and not a floor because, in order to be more competitive in the individual circumstance, you may offer a larger discount depending on the items or services purchased and the quantity at time of sale.

Must answer with a number between 0% and 100%.

3 **TIPS Administration Fee**

6

By submitting a proposal, I agree that all pricing submitted to TIPS shall include the Administration Fee, as designated in the solicitation or as otherwise agreed in writing which shall be remitted to TIPS by the Vendor, or the vendor's named resellers, and as agreed to in the Vendor Agreement. I agree that the fee shall not and will not be added by the Vendor as a separate line item on a TIPS member invoice, quote, proposal or any other written communications with the TIPS member.

3
7

Yes - No

Vendor agrees to remit to TIPS the required administration fee or, if resellers are named, Vendor agrees to guarantee the fee remittance by or for the reseller named by the vendor?

TIPS/ESC Region 8 is required by Texas Government Code § 791 to be compensated for its work and thus, failure to agree shall render your response void and it will not be considered.

3
8

Yes - No

Do you offer additional discounts to TIPS members for large order quantities or large scope of work?

3
9

Years experience in category of goods or services

Company years experience in this category of goods or services? This is an evaluation criterion worth a maximum of 10 points. See RFP for more information.

4
0

Resellers:

Does the vendor have resellers that it will name under this contract? Resellers are defined as other companies that sell your products under an agreement with you, the awarded vendor of TIPS.

EXAMPLE: BIGmart is a reseller of ACME brand televisions. If ACME were a TIPS awarded vendor, then ACME would list BIGmart as a reseller.

(If applicable, vendor should download the Reseller/Dealers spreadsheet from the Attachments section, fill out the form and submit the document in the "Response Attachments" RESELLERS section.

4
1

Pricing discount percentage are guaranteed for?

Does the vendor agrees to honor the proposed pricing discount percentage off regular catalog (as defined in the RFP document), website, store or shelf pricing for the term of the award?

4
2

Right of Refusal

Does the proposing vendor wish to reserve the right not to perform under the awarded agreement with a TIPS member at vendor's discretion?

4 **NON-COLLUSIVE BIDDING CERTIFICATE**

3 By submission of this bid or proposal, the Bidder certifies that:

- 1) This bid or proposal has been independently arrived at without collusion with any other Bidder or with any Competitor;
- 2) This bid or proposal has not been knowingly disclosed and will not be knowingly disclosed, prior to the opening of bids, or proposals for this project, to any other Bidder, Competitor or potential competitor:
- 3) No attempt has been or will be made to induce any other person, partnership or corporation to submit or not to submit a bid or proposal;
- 4) The person signing this bid or proposal certifies that he has fully informed himself regarding the accuracy of the statements contained in this certification, and under the penalties being applicable to the Bidder as well as to the person signing in its behalf.

Not a negotiable term. Failure to agree will render your proposal non-responsive and it will not be considered.

4 **CONFLICT OF INTEREST QUESTIONNAIRE - FORM CIQ - Do you have any CONFLICT OF INTEREST TO REPORT OR DISCLOSE under this statutory requirement?**

Do you have any CONFLICT OF INTEREST TO REPORT OR DISCLOSE under this statutory requirement? YES or NO

If you have a conflict of interest as described in this form or the Local Government Code Chapter 176, cited therein- you are required to complete and file with TIPS.

You may find the Blank CIQ form on our website at:

Copy and Paste the following link into a new browser or tab:

<https://www.tips-usa.com/assets/documents/docs/CIQ.pdf>

There is an optional upload for this form provided if you have a conflict and must file the form.

4 **Filing of Form CIQ**

5 If yes (above), have you filed a form CIQ by uploading the form to this RFP as directed above?

4 **Regulatory Standing**

6 I certify to TIPS for the proposal attached that my company is in good standing with all governmental agencies Federal or state that regulate any part of our business operations. If not, please explain in the next attribute question.

4 **Regulatory Standing**

7 Regulatory Standing explanation of no answer on previous question.

Antitrust Certification Statements (Tex. Government Code § 2155.005)

By submission of this bid or proposal, the Bidder certifies that:

I affirm under penalty of perjury of the laws of the State of Texas that:

(1) I am duly authorized to execute this contract on my own behalf or on behalf of the company, corporation, firm, partnership or individual (Company) listed below;

(2) In connection with this bid, neither I nor any representative of the Company has violated any provision of the Texas Free Enterprise and Antitrust Act, Tex. Bus. & Comm. Code Chapter 15;

(3) In connection with this bid, neither I nor any representative of the Company has violated any federal antitrust law;

(4) Neither I nor any representative of the Company has directly or indirectly communicated any of the contents of this bid to a competitor of the Company or any other company, corporation, firm, partnership or individual engaged in the same line of business as the Company.

Suspension or Debarment Instructions

Instructions for Certification:

1. By answering yes to the next Attribute question below, the vendor and prospective lower tier participant is providing the certification set out herein in accordance with these instructions.
2. The certification in this clause is a material representation of fact upon which reliance was placed when this transaction was entered into. If it is later determined that the prospective lower tier participant knowingly rendered an erroneous certification in addition to other remedies available to the federal government, the department or agency with which this transaction originated may pursue available remedies, including suspension and / or debarment.
3. The prospective lower tier participant shall provide immediate written notice to the person to which this proposal is submitted if at any time the prospective lower tier participant learns that its certification was erroneous when submitted or has become erroneous by reason of changed circumstances.
4. The terms “covered transaction,” “debarred,” “suspended,” “ineligible,” “lower tier covered transaction,” “participants,” “person,” “primary covered transaction,” “principal,” “proposal” and “voluntarily excluded,” as used in this clause, have the meanings set out in the Definitions and Coverage sections of rules implementing Executive Order 12549. You may contact the person to which this proposal is submitted for assistance in obtaining a copy of those regulations.
5. The prospective lower tier participant agrees by submitting this form that, should the proposed covered transaction be entered into, it shall not knowingly enter into any lower tier covered transaction with a person who is debarred, suspended, declared ineligible or voluntarily excluded from participation in this covered transaction, unless authorized by the department or agency with which this transaction originated.
6. The prospective lower tier participant further agrees by submitting this form that it will include this clause titled “Certification Regarding Debarment, Suspension, Ineligibility and Voluntary Exclusion-Lower Tier Covered Transaction” without modification in all lower tier covered transactions and in all solicitations for lower tier covered transactions.
7. A participant in a covered transaction may rely upon a certification of a prospective participant in a lower tier covered transaction that it is not debarred, suspended, ineligible or voluntarily excluded from the covered transaction, unless it knows that the certification is erroneous. A participant may decide the method and frequency by which it determines the eligibility of its principals. Each participant may, but is not required to, check the Nonprocurement List.
8. Nothing contained in the foregoing shall be construed to require establishment of a system of records in order to render in good faith the certification required by this clause. The knowledge and information of a participant is not required to exceed that which is normally possessed by a prudent person in the ordinary course of business dealings.
9. Except for transactions authorized under paragraph 5 of these instructions, if a participant in a covered transaction knowingly enters into a lower tier covered transaction with a person who is suspended, debarred, ineligible or voluntarily excluded from participation in this transaction, in addition to other remedies available to the federal government, the department or agency with which this transaction originated may pursue available remedies, including suspension and / or debarment.

5
0

Suspension or Debarment Certification

By answering yes, you certify that no federal suspension or debarment is in place, which would preclude receiving a federally funded contract as described above.

Debarment and Suspension (Executive Orders 12549 and 12689)—A contract award (see 2 CFR 180.220) must not be made to parties listed on the government-wide exclusions in the System for Award Management (SAM), in accordance with the OMB guidelines at 2 CFR 180 that implement Executive Orders 12549 (3 CFR part 1986 Comp., p. 189) and 12689 (3 CFR part 1989 Comp., p. 235), "Debarment and Suspension." SAM Exclusions contains the names of parties debarred, suspended, or otherwise excluded by agencies, as well as parties declared ineligible under statutory or regulatory authority other than Executive Order 12549.

By answering yes, you certify that no federal suspension or debarment is in place, which would preclude receiving a federally funded contract as described above.

5
1

Non-Discrimination Statement and Certification

In accordance with Federal civil rights law, all U.S. Departments, including the U.S. Department of Agriculture (USDA) civil rights regulations and policies, the USDA, its Agencies, offices, and employees, and institutions participating in or administering USDA programs are prohibited from discriminating based on race, color, national origin, religion, sex, gender identity (including gender expression), sexual orientation, disability, age, marital status, family/parental status, income derived from a public assistance program, political beliefs, or reprisal or retaliation for prior civil rights activity, in any program or activity conducted or funded by USDA (not all bases apply to all programs). Remedies and complaint filing deadlines vary by program or incident.

Persons with disabilities who require alternative means of communication for program information (e.g., Braille, large print, audiotape, American Sign Language, etc.) should contact the responsible Agency or USDA's TARGET Center at (202) 720-2600 (voice and TTY) or contact USDA through the Federal Relay Service at (800) 877-8339. Additionally, program information may be made available in languages other than English.

To file a program discrimination complaint, complete the USDA Program Discrimination Complaint Form, AD-3027, found online at [How to File a Program Discrimination Complaint](#) and at any USDA office or write a letter addressed to USDA and provide in the letter all of the information requested in the form. To request a copy of the complaint form, call (866) 632-9992. Submit your completed form or letter to USDA by: (1) mail: U.S. Department of Agriculture, Office of the Assistant Secretary for Civil Rights, 1400 Independence Avenue, SW, Washington, D.C. 20250-9410; (2) fax: (202) 690-7442; or (3) email: program.intake@usda.gov.

(Title VI of the Education Amendments of 1972; Section 504 of the Rehabilitation Act of 1973; the Age Discrimination Act of 1975; Title 7 CFR Parts 15, 15a, and 15b; the Americans with Disabilities Act; and FNS Instruction 113-1, Civil Rights Compliance and Enforcement – Nutrition Programs and Activities)

All U.S. Departments, including the USDA are equal opportunity provider, employer, and lender.

Not a negotiable term. Failure to agree by answering YES will render your proposal non-responsive and it will not be considered. I certify that in the performance of a contract with TIPS or its members, that our company will conform to the foregoing anti-discrimination statement and comply with the cited and all other applicable laws and regulations.

5 **2 CFR PART 200 Contract Provisions Explanation**

2 Required Federal contract provisions of Federal Regulations for Contracts for contracts with ESC Region 8 and TIPS Members:

The following provisions are required to be in place and agreed if the procurement is funded in any part with federal funds.

The ESC Region 8 and TIPS Members are the subgrantee or Subrecipient by definition. Most of the provisions are located in 2 CFR PART 200 - Appendix II to Part 200—Contract Provisions for Non-Federal Entity Contracts Under Federal Awards at 2 CFR PART 200. Others are included within 2 CFR part 200 et al.

In addition to other provisions required by the Federal agency or non-Federal entity, all contracts made by the non-Federal entity under the Federal award must contain provisions covering the following, as applicable.

5 **2 CFR PART 200 Contracts**

3 Contracts for more than the simplified acquisition threshold currently set at \$150,000, which is the inflation adjusted amount determined by the Civilian Agency Acquisition Council and the Defense Acquisition Regulations Council (Councils) as authorized by 41 U.S.C. 1908, must address administrative, contractual, or legal remedies in instances where contractors violate or breach contract terms, and provide for such sanctions and penalties as appropriate.

Notice: Pursuant to the above, when federal funds are expended by ESC Region 8 and TIPS Members, ESC Region 8 and TIPS Members reserves all rights and privileges under the applicable laws and regulations with respect to this procurement in the event of breach of contract by either party.

Does vendor agree?

5 **2 CFR PART 200 Termination**

4 Termination for cause and for convenience by the grantee or subgrantee including the manner by which it will be effected and the basis for settlement. (All contracts in excess of \$10,000)

Pursuant to the above, when federal funds are expended by ESC Region 8 and TIPS Members, ESC Region 8 and TIPS Members reserves the right to terminate any agreement in excess of \$10,000 resulting from this procurement process for cause after giving the vendor an appropriate opportunity and up to 30 days, to cure the causal breach of terms and conditions. ESC Region 8 and TIPS Members reserves the right to terminate any agreement in excess of \$10,000 resulting from this procurement process for convenience with 30 days notice in writing to the awarded vendor. The vendor would be compensated for work performed and goods procured as of the termination date if for convenience of the ESC Region 8 and TIPS Members. Any award under this procurement process is not exclusive and the ESC Region 8 and TIPS reserves the right to purchase goods and services from other vendors when it is in the best interest of the ESC Region 8 and TIPS.

Does vendor agree?

5
5

2 CFR PART 200 Clean Air Act

Clean Air Act (42 U.S.C. 7401-7671q.) and the Federal Water Pollution Control Act (33 U.S.C. 1251-1387), as amended—Contracts and subgrants of amounts in excess of \$150,000 must contain a provision that requires the non-Federal award to agree to comply with all applicable standards, orders or regulations issued pursuant to the Clean Air Act (42 U.S.C. 7401-7671q) and the Federal Water Pollution Control Act as amended (33 U.S.C. 1251-1387). Violations must be reported to the Federal awarding agency and the Regional Office of the Environmental Protection Agency (EPA).

Pursuant to the Clean Air Act, et al above, when federal funds are expended by ESC Region 8 and TIPS Members, ESC Region 8 and TIPS Members requires that the proposer certify that during the term of an award by the ESC Region 8 and TIPS Members resulting from this procurement process the vendor agrees to comply with all of the above regulations, including all of the terms listed and referenced therein.

Does vendor agree?

5
6

2 CFR PART 200 Byrd Anti-Lobbying Amendment

Byrd Anti-Lobbying Amendment (31 U.S.C. 1352)—Contractors that apply or bid for an award exceeding \$100,000 must file the required certification. Each tier certifies to the tier above that it will not and has not used Federal appropriated funds to pay any person or organization for influencing or attempting to influence an officer or employee of any agency, a member of Congress, officer or employee of Congress, or an employee of a member of Congress in connection with obtaining any Federal contract, grant or any other award covered by 31 U.S.C. 1352. Each tier must also disclose any lobbying with non-Federal funds that takes place in connection with obtaining any Federal award. Such disclosures are forwarded from tier to tier up to the non-Federal award.

Pursuant to the above, when federal funds are expended by ESC Region 8 and TIPS Members, ESC Region 8 and TIPS Members requires the proposer certify that during the term and during the life of any contract with ESC Region 8 and TIPS Members resulting from this procurement process the vendor certifies to the terms included or referenced herein.

Does vendor agree?

5
7

2 CFR PART 200 Federal Rule

Compliance with all applicable standards, orders, or requirements issued under section 306 of the Clean Air Act (42 U.S.C. 1857(h)), section 508 of the Clean Water Act (33 U.S.C. 1368), Executive Order 11738, and Environmental Protection Agency regulations (40 CFR part 15). (Contracts, subcontracts, and subgrants of amounts in excess of \$100,000)

Pursuant to the above, when federal funds are expended by ESC Region 8 and TIPS Members, ESC Region 8 and TIPS Members requires the proposer certify that in performance of the contracts, subcontracts, and subgrants of amounts in excess of \$100,000, the vendor will be in compliance with all applicable standards, orders, or requirements issued under section 306 of the Clean Air Act (42 U.S.C. 1857(h)), section 508 of the Clean Water Act (33 U.S.C. 1368), Executive Order 11738, and Environmental Protection Agency regulations (40 CFR part 15).

Does vendor certify that it is in compliance with the Clean Air Act?

58 2 CFR PART 200 Procurement of Recovered Materials

A non-Federal entity that is a state agency or agency of a political subdivision of a state and its contractors must comply with section 6002 of the Solid Waste Disposal Act, as amended by the Resource Conservation and Recovery Act. The requirements of Section 6002 include procuring only items designated in guidelines of the Environmental Protection Agency (EPA) at 40 CFR part 247 that contain the highest percentage of recovered materials practicable, consistent with maintaining a satisfactory level of competition, where the purchase price of the item exceeds \$10,000 or the value of the quantity acquired during the preceding fiscal year exceeded \$10,000; procuring solid waste management services in a manner that maximizes energy and resource recovery; and establishing an affirmative procurement program for procurement of recovered materials identified in the EPA guidelines.

Does vendor certify that it is in compliance with the Solid Waste Disposal Act as described above?

59 Certification Regarding Lobbying

Applicable to Grants, Subgrants, Cooperative Agreements, and Contracts Exceeding \$100,000 in Federal Funds

Submission of this certification is a prerequisite for making or entering into this transaction and is imposed by section 1352, Title 31, U.S. Code. This certification is a material representation of fact upon which reliance was placed when this transaction was made or entered into. Any person who fails to file the required certification shall be subject to a civil penalty of not less than \$10,000 and not more than \$100,000 for each such failure.

The undersigned certifies, to the best of his or her knowledge and belief, that:

(1) No Federal appropriated funds have been paid or will be paid by or on behalf of the undersigned, to any person for influencing or attempting to influence an officer or employee of any agency, a Member of Congress, an officer or employee of congress, or an employee of a Member of Congress in connection with the awarding of a Federal contract, the making of a Federal grant, the making of a Federal loan, the entering into a cooperative agreement, and the extension, continuation, renewal, amendment, or modification of a Federal contract, grant, loan, or cooperative agreement.

(2) If any funds other than Federal appropriated funds have been paid or will be paid to any person for influencing or attempting to influence an officer or employee of any agency, a Member of Congress, an officer or employee of congress, or an employee of a Member of Congress in connection with this Federal grant or cooperative agreement, the undersigned shall complete and submit Standard Form-LLL, "disclosure Form to Report Lobbying," in accordance with its instructions.

(3) The undersigned shall require that the language of this certification be included in the award documents for all covered subawards exceeding \$100,000 in Federal funds at all appropriate tiers and that all subrecipients shall certify and disclose accordingly.

60 If you answered "I HAVE lobbied" to the above Attribute Question

If you answered "I HAVE lobbied" to the above Attribute question, you must download the Lobbying Report "Standard From LLL, disclosure Form to Report Lobbying" which includes instruction on completing the form, complete and submit it in the Response Attachments section as a report of the lobbying activities you performed or paid others to perform.

**6
1 Subcontracting with Small and Minority Businesses, Women's Business Enterprises, and Labor Surplus Area Firms.**

Do you ever anticipate the possibility of subcontracting any of your work under this award if you are successful?

IF NO, DO NOT ANSWER THE NEXT ATTRIBUTE QUESTION. . IF YES, and ONLY IF YES, you must answer the next question YES if you want a TIPS Member to be authorized to spend Federal Grant Funds for Procurement.

YES

**6
2 ONLY IF YES TO THE PREVIOUS QUESTION OR if you ever do subcontract any part of your performance under the TIPS Agreement, do you agree to comply with the following federal requirements?**

ONLY IF YES TO THE PREVIOUS QUESTION OR if you ever do subcontract any part of your performance under the TIPS Agreement,

do you agree to comply with the following federal requirements?

Federal Regulation 2 CFR §200.321 Contracting with small and minority businesses, women's business enterprises, and labor surplus area firms. (a)The non-Federal entity must take all necessary affirmative steps to assure that minority businesses, women's business enterprises, and labor surplus area firms are used when possible.

(b) Affirmative steps must include:

(1) Placing qualified small and minority businesses and women's business enterprises on solicitation lists;

(2) Assuring that small and minority businesses, and women's business enterprises are solicited whenever they are potential sources;

(3) Dividing total requirements, when economically feasible, into smaller tasks or quantities to permit maximum participation by small and minority businesses, and women's business enterprises;

(4) Establishing delivery schedules, where the requirement permits, which encourage participation by small and minority businesses, and women's business enterprises;

(5) Using the services and assistance, as appropriate, of such organizations as the Small Business Administration and the Minority Business Development Agency of the Department of Commerce ; and

(6) Requiring the prime contractor, if subcontracts are to be let, to take the affirmative steps listed in paragraphs(1) through (5) of this section.

YES

6 **Indemnification**

3

The ESC Region 8 and TIPS is a Texas Political Subdivision and a local governmental entity; therefore, is prohibited from indemnifying third parties pursuant to the Texas Constitution (Article 3, Section 52) except as specifically provided by law or as ordered by a court of competent jurisdiction. A provision in a contract to indemnify or hold a party harmless is a promise to pay for any expenses the indemnified party incurs, if a specified event occurs, such as breaching the terms of the contract or negligently performing duties under the contract. Article III, Section 49 of the Texas Constitution states that "no debt shall be created by or on behalf of the State ... " The Attorney General has counseled that a contractually imposed obligation of indemnity creates a "debt" in the constitutional sense. Tex. Att'y Gen. Op. No. MW-475 (1982). Contract clauses which require the System or institutions to indemnify must be deleted or qualified with "to the extent permitted by the Constitution and Laws of the State of Texas." Liquidated damages, attorney's fees, waiver of vendor's liability, and waiver of statutes of limitations clauses should also be deleted or qualified with "to the extent permitted by the Constitution and laws of State of Texas."

Not a negotiable term. Failure to agree will render your proposal non-responsive and it will not be considered. Do you agree to these terms?

6 **Remedies**

4

The parties shall be entitled to exercise any right or remedy available to it either at law or in equity, subject to the choice of law, venue and service of process clauses limitations agreed herein. Nothing in this agreement shall commit the TIPS to an arbitration resolution of any disagreement under any circumstances. Any Claim arising out of or related to the Contract, except for those specifically waived under the terms of the Contract, may, after denial of the Board of Directors, be subject to mediation at the request of either party. Any issues not resolved hereunder MAY be referred to non-binding mediation to be conducted by a mutually agreed upon mediator as a prerequisite to the filing of any lawsuit over such issue(s). The parties shall share the mediator's fee and any associated filing fee equally. Mediation shall be held in Camp or Titus County, Texas. Agreements reached in mediation shall be reduced to writing, and will be subject to the approval by the District's Board of Directors, signed by the Parties if approved by the Board of Directors, and, if signed, shall thereafter be enforceable as provided by the laws of the State of Texas.

Do you agree to these terms?

6 **Remedies Explanation of No Answer**

5

6
6 **Choice of Law**

The agreement between the Vendor and TIPS/ESC Region 8 and any addenda or other additions resulting from this procurement process, however described, shall be governed by, construed and enforced in accordance with the laws of the State of Texas, regardless of any conflict of laws principles.
THIS DOES NOT APPLY to a vendor's agreement entered into with a TIPS Member, as the Member may be located outside Texas.

Do you agree to these terms?

6
7 **Venue, Jurisdiction and Service of Process**

Any Proceeding arising out of or relating to this procurement process or any contract issued by TIPS resulting from or any contemplated transaction shall be brought in a court of competent jurisdiction in Camp County, Texas and each of the parties irrevocably submits to the exclusive jurisdiction of said court in any such proceeding, waives any objection it may now or hereafter have to venue or to convenience of forum, agrees that all claims in respect of the Proceeding shall be heard and determined only in any such court, and agrees not to bring any proceeding arising out of or relating to this procurement process or any contract resulting from or any contemplated transaction in any other court. The parties agree that either or both of them may file a copy of this paragraph with any court as written evidence of the knowing, voluntary and freely bargained for agreement between the parties irrevocably to waive any objections to venue or to convenience of forum. Process in any Proceeding referred to in the first sentence of this Section may be served on any party anywhere in the world. Any dispute resolution process other than litigation shall have venue in Camp County or Titus County Texas.

Do you agree to these terms?

6
8 **Infringement(s)**

The successful vendor will be expected to indemnify and hold harmless the TIPS and its employees, officers, agents, representatives, contractors, assignees and designees from any and all third party claims and judgments involving infringement of patent, copyright, trade secrets, trade or service marks, and any other intellectual or intangible property rights attributed to or claims based on the Vendor's proposal or Vendor's performance of contracts awarded and approved.

Do you agree to these terms?

6
9 **Infringement(s) Explanation of No Answer**

7
0 **Contract Governance**

Any contract made or entered into by the TIPS is subject to and is to be governed by Section 271.151 et seq, Tex Loc Gov't Code. Otherwise, TIPS does not waive its governmental immunities from suit or liability except to the extent expressly waived by other applicable laws in clear and unambiguous language.

7
1

Payment Terms and Funding Out Clause

Payment Terms:

TIPS or TIPS Members shall not be liable for interest or late payment fees on past-due balances at a rate higher than permitted by the laws or regulations of the jurisdiction of the TIPS Member.

Funding Out Clause:

Vendor agrees to abide by the laws and regulations, including Texas Local Government Code § 271.903, or any statutory or regulatory limitations of the jurisdiction of any TIPS Member which governs contracts entered into by the Vendor and TIPS or a TIPS Member that requires all contracts approved by TIPS or a TIPS Member are subject to the budgeting and appropriation of currently available funds by the entity or its governing body.

See statute(s) for specifics or consult your legal counsel.

Not a negotiable term. Failure to agree will render your proposal non-responsive and it will not be considered.

Do you agree to these terms?

7
2

Insurance and Fingerprint Requirements Information

Insurance

If applicable and your staff will be on TIPS member premises for delivery, training or installation etc. and/or with an automobile, you must carry automobile insurance as required by law. You may be asked to provide proof of insurance.

Fingerprint

It is possible that a vendor may be subject to Chapter 22 of the Texas Education Code. The Texas Education Code, Chapter 22, Section 22.0834. Statutory language may be found at: <http://www.statutes.legis.state.tx.us/>

If the vendor has staff that meet both of these criterion:

- (1) will have continuing duties related to the contracted services; and
- (2) has or will have direct contact with students

Then you have "covered" employees for purposes of completing the attached form.

TIPS recommends all vendors consult their legal counsel for guidance in compliance with this law. If you have questions on how to comply, see below. If you have questions on compliance with this code section, contact the Texas Department of Public Safety Non-Criminal Justice Unit, Access and Dissemination Bureau, FAST-FACT at NCJU@txdps.state.tx.us and you should send an email identifying you as a contractor to a Texas Independent School District or ESC Region 8 and TIPS. Texas DPS phone number is (512) 424-2474.

See form in the next attribute to complete entitled:
Texas Education Code Chapter 22 Contractor Certification for Contractor Employees

Texas Education Code Chapter 22 Contractor Certification for Contractor Employees

Introduction: Texas Education Code Chapter 22 requires entities that contract with school districts to provide services to obtain criminal history record information regarding covered employees. Contractors must certify to the district that they have complied. Covered employees with disqualifying criminal histories are prohibited from serving at a school district.

Definitions: Covered employees: Employees of a contractor or subcontractor who have or will have continuing duties related to the service to be performed at the District and have or will have direct contact with students. The District will be the final arbiter of what constitutes direct contact with students. Disqualifying criminal history: Any conviction or other criminal history information designated by the District, or one of the following offenses, if at the time of the offense, the victim was under 18 or enrolled in a public school:

(a) a felony offense under Title 5, Texas Penal Code; (b) an offense for which a defendant is required to register as a sex offender under Chapter 62, Texas Code of Criminal Procedure; or (c) an equivalent offense under federal law or the laws of another state.

I certify that:

NONE (Section A) of the employees of Contractor and any subcontractors are covered employees, as defined above. If this box is checked, I further certify that Contractor has taken precautions or imposed conditions to ensure that the employees of Contractor and any subcontractor will not become covered employees. Contractor will maintain these precautions or conditions throughout the time the contracted services are provided.

OR

SOME (Section B) or all of the employees of Contractor and any subcontractor are covered employees. If this box is checked, I further certify that:

(1) Contractor has obtained all required criminal history record information regarding its covered employees. None of the covered employees has a disqualifying criminal history.

(2) If Contractor receives information that a covered employee subsequently has a reported criminal history, Contractor will immediately remove the covered employee from contract duties and notify the District in writing within 3 business days.

(3) Upon request, Contractor will provide the District with the name and any other requested information of covered employees so that the District may obtain criminal history record information on the covered employees.

(4) If the District objects to the assignment of a covered employee on the basis of the covered employee's criminal history record information, Contractor agrees to discontinue using that covered employee to provide services at the District.

Noncompliance or misrepresentation regarding this certification may be grounds for contract termination.

None

7 **Texas Business and Commerce Code § 272 Requirements as of 9-1-2017**

4 SB 807 prohibits construction contracts to have provisions requiring the contract to be subject to the laws of another state, to be required to litigate the contract in another state, or to require arbitration in another state. A contract with such provisions is voidable. Under this new statute, a “construction contract” includes contracts, subcontracts, or agreements with (among others) architects, engineers, contractors, construction managers, equipment lessors, or materials suppliers. “Construction contracts” are for the design, construction, alteration, renovation, remodeling, or repair of any building or improvement to real property, or for furnishing materials or equipment for the project. The term also includes moving, demolition, or excavation. BY RESPONDING TO THIS SOLICITATION, AND WHEN APPLICABLE, THE PROPOSER AGREES TO COMPLY WITH THE TEXAS BUSINESS AND COMMERCE CODE § 272 WHEN EXECUTING CONTRACTS WITH TIPS MEMBERS THAT ARE TEXAS GOVERNMENT ENTITIES.

7 **Texas Government Code 2270 Verification Form**

5 Texas Government Code 2270 Verification Form

Texas 2017 House Bill 89 has been signed into law by the governor and as of September 1, 2017 will be codified as Texas Government Code § 2270 and 808 et seq.

The relevant section addressed by this form reads as follows:
Texas Government Code Sec. 2270.002. PROVISION REQUIRED IN CONTRACT. A governmental entity may not enter into a contract with a company for goods or services unless the contract contains a written verification from the company that it: (1) does not boycott Israel; and (2) will not boycott Israel during the term of the contract engaged by:

ESC Region 8/The Interlocal Purchasing System (TIPS)
4845 Highway 271 North
Pittsburg, TX, 75686

I verify by this writing that the above-named company affirms that it (1) does not boycott Israel; and (2) will not boycott Israel during the term of this contract, or any contract with the above-named Texas governmental entity in the future. I further affirm that if our company’s position on this issue is reversed and this affirmation is no longer valid, that the above-named Texas governmental entity will be notified in writing within one (1) business day and we understand that our company’s failure to affirm and comply with the requirements of Texas Government Code 2270 et seq. shall be grounds for immediate contract termination without penalty to the above-named Texas governmental entity.

AND

Our company is not listed on and we do not do business with companies that are on the the Texas Comptroller of Public Accounts list of Designated Foreign Terrorists Organizations per Texas Gov't Code 2270.0153 found at <https://comptroller.texas.gov/purchasing/docs/foreign-terrorist.pdf>

I swear and affirm that the above is true and correct.

**7
6** **Logos and other company marks**

Please upload your company logo to be added to your individual profile page on the TIPS website. If any particular specifications are required for use of your company logo, please upload that information under the "Logo and Other Company Marks" section under the "Response Attachment" tab. Preferred Logo Format: 300 x 225 px - .png, .eps, .jpeg preferred

Potential uses of company logo:

- * Your Vendor Profile Page of TIPS website
- * Potentially on TIPS website scroll bar for Top Performing Vendors
- * TIPS Quarterly eNewsletter sent to TIPS Members
- * Co-branding Flyers and or email blasts to our TIPS Members (Permission and approval will be obtained before publishing)

**7
7** **Solicitation Deviation/Compliance**

Does the vendor agree with the General Conditions Standard Terms and Conditions or Item Specifications listed in this proposal invitation?

**7
8** **Solicitation Exceptions/Deviations Explanation**

If the bidder intends to deviate from the General Conditions Standard Terms and Conditions or Item Specifications listed in this proposal invitation, all such deviations must be listed on this attribute, with complete and detailed conditions and information included or attached. TIPS will consider any deviations in its proposal award decisions, and TIPS reserves the right to accept or reject any bid based upon any deviations indicated below or in any attachments or inclusions. In the absence of any deviation entry on this attribute, the proposer assures TIPS of their full compliance with the Standard Terms and Conditions, Item Specifications, and all other information contained in this Solicitation.

**7
9** **Agreement Deviation/Compliance**

Does the vendor agree with the language in the Vendor Agreement?

**8
0** **Agreement Exceptions/Deviations Explanation**

If the proposing Vendor desires to deviate from the Vendor Agreement language, all such deviations must be listed on this attribute, with complete and detailed conditions and information included. TIPS will consider any deviations in its proposal award decisions, and TIPS reserves the right to accept or reject any proposal based upon any deviations indicated below. In the absence of any deviation entry on this attribute, the proposer assures TIPS of their full compliance with the Vendor Agreement.

**8
1** **Felony Conviction Notice**

Texas Education Code, Section 44.034, Notification of Criminal History, Subsection (a), states “a person or business entity that enters into a contract with a school district must give advance notice to the district if the person or an owner or operator of the business entity has been convicted of a felony. The notice must include a general description of the conduct resulting in the conviction of a felony.” Subsection (b) states “a school district may terminate a contract with a person or business entity if the district determines that the person or business entity failed to give notice as required by Subsection (a) or misrepresented the conduct resulting in the conviction. The district must compensate the person or business entity for services performed before the termination of the contract.” (c) This section does not apply to a publicly held corporation. The person completing this proposal certifies that they are authorized to provide the answer to this question.

Select A., B. or C.

A. My firm is a publicly held corporation; therefore, this reporting requirement is not applicable.

OR B. My firm is not owned nor operated by anyone who has been convicted of a felony, OR

C. My firm is owned or operated by the following individual(s) who has/have been convicted of a felony. (if you answer C below, you are required to provide information in the next attribute.

B. Firm not owned nor operated by felon; per above

**8
2** **If you answered C. My Firm is owned or operated by a felon to the previous question, you are REQUIRED TO ANSWER THE FOLLOWING QUESTIONS.**

If you answered C. My Firm is owned or operated by a felon to the previous question, you must provide the following information.

1. Name of Felon(s)
2. The named person's role in the firm, and
3. Details of Conviction(s).

No response

**8
3** **Long Term Cost Evaluation Criterion # 4.**

READ CAREFULLY and see in the RFP document under "Proposal Scoring and Evaluation". Points will be assigned to this criterion based on your answer to this Attribute. Points are awarded if you agree not increase your catalog prices (as defined herein) more than X% annually over the previous year for years two and three and potentially year four, unless an exigent circumstance exists in the marketplace and the excess price increase which exceeds X% annually is supported by documentation provided by you and your suppliers and shared with TIPS, if requested. If you agree NOT to increase prices more than 5%, except when justified by supporting documentation, you are awarded 10 points; if 6% to 14%, except when justified by supporting documentation, you receive 1 to 9 points incrementally. Price increases 14% or greater, except when justified by supporting documentation, receive 0 points.

increases will be 5% or less annually per question

**8
4** **Required Confidentiality Claim Form**

Required Confidentiality Claim Form

This completed form is required by TIPS. By submitting a response to this solicitation you agree to download from the “Attachments” section, complete according to the instructions on the form, then uploading the completed form, with any confidential attachments, if applicable, to the “Response Attachments” section titled “Confidentiality Form” in order to provide to TIPS the completed form titled, “CONFIDENTIALITY CLAIM FORM”. By completing this process, you provide us with the information we require to comply with the open record laws of the State of Texas as they may apply to your proposal submission. If you do not provide the form with your proposal, an award will not be made if your proposal is qualified for an award, until TIPS has an accurate, completed form from you.

Read the form carefully before completing and if you have any questions, email Rick Powell at TIPS at rick.powell@tips-usa.com

85 Choice of Law clauses with TIPS Members

If the vendor is awarded a contract with TIPS under this solicitation, the vendor agrees to make any Choice of Law clauses in any contract or agreement entered into between the awarded vendor and with a TIPS member entity to read as follows: "Choice of law shall be the laws of the state where the customer resides" or words to that effect.

86 Venue of dispute resolution with a TIPS Member

In the event of litigation or use of any dispute resolution model when resolving disputes with a TIPS member entity as a result of a transaction between the vendor and TIPS or the TIPS member entity, the Venue for any litigation or other agreed upon model shall be in the state and county where the customer resides unless otherwise agreed by the parties at the time the dispute resolution model is decided by the parties.

87 Automatic renewal of contracts or agreements with TIPS or a TIPS member entity

This clause **DOES NOT** prohibit multiyear contracts or agreements with TIPS member entities. Because TIPS and TIPS members are governmental entities subject to laws that control appropriations of funds during their fiscal years for contracts and agreements to provide goods and services, does the Vendor agree to limit any automatic renewal clauses of a contract or agreement executed as a result of this TIPS solicitation award to not longer than "month to month" and at the TIPS contracted rate.

88 Indemnity Limitation with TIPS Members

Texas and other states restrict by law or state Constitution the ability of a governmental entity to indemnify others. TIPS requires that any contract entered into between a vendor and TIPS or a TIPS Member as a result of an award under this Solicitation limit the requirement that the Customer indemnify the Vendor by either eliminating any such indemnity requirement clauses in any agreements, contracts or other binding documents **OR** by prefacing all indemnity clauses required of TIPS or the TIPS Member entity with the following: "To the extent permitted by the laws or the Constitution of the state where the customer resides, ".

Agreement is a required condition to award of a contract resulting from this Solicitation.

89 Arbitration Clauses

Except for certain circumstances, TIPS forbids a mandatory arbitration clause in any contract or agreement entered into between the awarded vendor with TIPS or a TIPS member entity. Does the vendor agree to exclude any arbitration requirement in any contracts or agreement entered into between TIPS or a TIPS member entity through an awarded contract with TIPS?

90 Required Vendor Sales Reporting

By responding to this Solicitation, you agree to report to TIPS all sales made under any awarded Agreement with TIPS. Vendor is required to report all sales under the TIPS contract to TIPS. If the TIPS Member entity requesting a price from the awarded Vendor requests the TIPS contract, Vendor must include the TIPS Contract number on any communications with the TIPS Member entity. If awarded, you will be provided access to the Vendor Portal. To report sales, login to the TIPS Vendor Portal and click on the PO's and Payments tab. Pages 3-7 of the [Vendor Portal User Guide](#) will walk you through the process of reporting sales to TIPS. Please refer to the TIPS [Accounting FAQ's](#) for more information about reporting sales and if you have further questions, contact the Accounting Team at accounting@tips-usa.com. The Vendor or vendor assigned dealers are responsible for keeping record of all sales that go through the TIPS Agreement and submitting same to TIPS.

Required Confidential Information Status Form

CONFIDENTIAL INFORMATION SUBMITTED IN RESPONSE TO COMPETITIVE PROCUREMENT REQUESTS OF EDUCATION SERVICE CENTER REGION 8 AND TIPS (ESC8) IS GOVERNED BY TEXAS GOVERNMENT CODE, CHAPTER 552

If you consider any portion of your proposal to be confidential information and not subject to public disclosure pursuant to Chapter 552 Texas Gov't Code or other law(s), you **must attach a copy of all claimed confidential materials within your proposal and put this COMPLETED form as a cover sheet to said materials then scan, name "CONFIDENTIAL" and upload with your proposal submission.** (You must include all the confidential information in the submitted proposal. The copy uploaded is to indicate which material in your proposal, if any, you deem confidential in the event the receives a Public Information Request.) ESC8 and TIPS will follow procedures of controlling statute(s) regarding any claim of confidentiality and shall not be liable for any release of information required by law. Upon your claim and your defense to the Office of Texas Attorney General is required to make the final determination whether the information submitted by you and held by ESC8 and TIPS is confidential and exempt from public disclosure.

VGI Technology

Name of company

Scott Gibbs CEO

Printed Name and Title of authorized company officer declaring below the confidential status of material

3321 Foster St San Angelo Tx 76903 325-223-3001

Address City State ZIP Phone

ALL VENDORS MUST COMPLETE THE ABOVE SECTION.

I DO CLAIM parts of my proposal to be confidential and DO NOT desire to expressly waive a claim of confidentiality of all information contained within our response to the solicitation. The attached contains material from our proposal that I classify and deem confidential under Texas Gov't Code Sec. 552 or other law(s) and I invoke my statutory rights to confidential treatment of the enclosed materials.

ATTACHED ARE COPIES OF _____ PAGES OF CLAIMED CONFIDENTIAL MATERIAL FROM OUR PROPOSAL THAT WE DEEM TO BE NOT PUBLIC INFORMATION AND WILL DEFEND THAT CLAIM TO THE TEXAS ATTORNEY GENERAL IF REQUESTED WHEN A PUBLIC INFORMATION REQUEST IS MADE FOR OUR PROPOSAL.

Signature _____ Date _____

OR -----

I DO NOT CLAIM any of my proposal to be confidential, complete the section below.

Express Waiver: I desire to expressly waive any claim of confidentiality as to any and all information contained within our response to the competitive procurement process (e.g. RFP, CSP, Bid, RFQ, etc.) by completing the following and submitting this sheet with our response to Education Service Center Region 8 and TIPS.

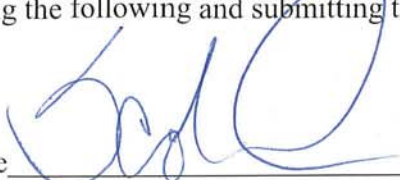
Signature 

Date 2/20/2020

H5A Camera Line

- 2 MP
- 4 MP
- 5 MP
- 6 MP
- 8 MP



Features



NEXT-GENERATION VIDEO ANALYTICS

Expanded object classifications and more accurate detection in crowded scenes so you can detect and act faster.



MADE IN NORTH AMERICA AND 5 YEAR WARRANTY

Manufactured in North America* using globally-sourced materials and North American expertise, Avigilon stands behind the quality of its products. Backed by a 5 year warranty.



H.265 WITH HDSM SMARTCODEC™ TECHNOLOGY

Optimizes compression levels for regions in a scene to help maximize bandwidth savings, helping to keep internet connectivity costs down.



FOCUS OF ATTENTION WITH ACC™ 7

Leverages AI and video analytics technologies to determine what information is important and should be presented to security operators.



TRUE WIDE DYNAMIC RANGE

Available in all resolutions, capture details in scenes with both very bright and dark areas.



LIGHTCATCHER™ TECHNOLOGY

Offers exceptional detail in areas with low lighting.



ONVIF® COMPLIANT

Built on an open platform to allow integration with other security solutions.



MULTIPLE LENS OPTIONS

Choose from various lens types, including long zoom, for flexible coverage options.

Specifications

		2.0 MP	4.0 MP	5.0 MP	6.0 MP	8.0 MP (4K ULTRA HD)		
IMAGE PERFORMANCE	Image Sensor	1/2.8" progressive scan CMOS				1/1.8" progressive scan CMOS		
	Max Resolution (H x V) and Aspect Ratio	(16:9) 1920 x 1080	(16:9) 2560 x 1440 (4:3) 2304 x 1728	(4:3) 2592 x 1944 (16:9) 2560 x 1440	(16:9) 3200 x 1800 (3:2) 3072 x 2048	(16:9) 3840 x 2160		
	WDR Off	83 dB	83 dB	83 dB	85 dB	85 dB		
	Dynamic Range	126 dB (dual exposure, 30 fps) 132 dB (triple exposure, 20 fps or less)	126 dB	126 dB	120 dB	120 dB		
	WDR On							
	Max Image Rate	(50 Hz/60 Hz): 25 fps/30 fps	WDR off (50 Hz/60 Hz): 25 fps/30 fps WDR on (50 Hz/60 Hz): 20 fps/20 fps		(50 Hz/60 Hz): 25 fps/30 fps			
	Bandwidth Management	HDSM SmartCodec technology; Idle scene mode						
	3D Noise Reduction Filter	Yes						
	LENS AND IR ILLUMINATION	IR Illumination Max Distance ¹ (high power 850 nm LEDs)	Dome	3.3 – 9 mm	4.9 – 8 mm	9 – 22 mm	4.7 – 84.6 mm	
			Bullet	35 m (115 ft), full tele 15 m (49 ft), full wide	30 m (98 ft), full tele 15 m (49 ft), full wide	N/A	N/A	
2 MP			50 m (164 ft), full tele 30 m (98 ft), full wide	50 m (164 ft), full tele 30 m (98 ft), full wide	90 m (295 ft), full tele 60 m (197 ft), full wide	N/A		
			0.027 lux in color mode, 0.014 lux in monochrome mode, 0 lux with IR	N/A	0.052 lux in color mode, 0.026 lux in monochrome mode, 0 lux with IR	0.039 lux in color mode, 0.02 lux in monochrome mode		
		4 MP		0.03 lux in color mode, 0.015 lux in monochrome mode, 0 lux with IR	N/A	0.058 lux in color mode, 0.029 lux in monochrome mode, 0 lux with IR	N/A	
				N/A	N/A	0.058 lux in color mode, 0.029 lux in monochrome mode, 0 lux with IR	N/A	
		5 MP		N/A	N/A	0.058 lux in color mode, 0.029 lux in monochrome mode, 0 lux with IR	N/A	
				N/A	0.055 lux in color mode, 0.028 lux in monochrome mode, 0 lux with IR	N/A	N/A	
		6 MP		N/A	0.055 lux in color mode, 0.028 lux in monochrome mode, 0 lux with IR	N/A	N/A	
				N/A	0.055 lux in color mode, 0.028 lux in monochrome mode, 0 lux with IR	N/A	N/A	
Horizontal Angle of View Based on Aspect Ratio		2 MP	(16:9) 34° – 99°	N/A	(16:9) 14° – 31°	(16:9) 4.1° – 60°		
		4 MP	(16:9)(4:3) 34° – 92°	N/A	(16:9)(4:3) 14° – 31° (4:3) 11° – 24°	N/A		
		5 MP	N/A	N/A	(16:9)(4:3) 14° – 31°	N/A		
		6 MP	N/A	(16:9) 52° – 92° (3:2) 41° – 73°	N/A	N/A		
		8 MP	N/A	(16:9) 52° – 92°	N/A	N/A		
		2 MP	(16:9) 18° – 53°	N/A	(16:9) 7.8° – 16.7°	(16:9) 2.3° – 34°		
		4 MP	(16:9) 18° – 50° (4:3) 25° – 68°	N/A	(16:9) 8.2° – 17.4°	N/A		
		5 MP	N/A	N/A	(16:9) 8.1° – 17.4° (4:3) 11° – 23°	N/A		
6 MP		N/A	(16:9) 29° – 51° (3:2) 27° – 48°	N/A	N/A			
8 MP		N/A	(16:9) 29° – 51°	N/A	N/A			
Max Aperture	F1.3	F1.8	F1.6	F1.6				
Control	P-Iris, Remote Focus and Zoom							
¹ IR illumination power may be reduced at higher operating temperatures.								
IMAGE CONTROL	Image Compression Method	H.264 HDSM SmartCodec, H.265 HDSM SmartCodec, Motion JPEG						
	Streaming	Multi-stream H.264, Multi-stream H.265, Motion JPEG; HDSM 2.0 on 4.0 MP, 5.0 MP, 6.0 MP, and 4K (8.0 MP) cameras						
	Motion Detection	Pixel motion: Selectable sensitivity and threshold. Classified object detection						
	Camera Tamper Detection	Yes						
	Electronic Shutter Control	Automatic, Manual (1/7 to 1/8196 sec)						
	Iris Control	Automatic, Open, Closed						
	Day/Night Control	Automatic, Manual						
	Flicker Control	60 Hz, 50 Hz						
	White Balance	Automatic, Manual						
	Backlight Compensation	Adjustable						
Privacy Zones	Up to 64 zones							
NETWORK	Network	100BASE-TX, RJ45 Connector, CAT5e Cabling						
	ONVIF	ONVIF compliance version 1.02, 2.00, Profile S, Profile T (www.onvif.org)						
	Security	Password protection, HTTPS encryption, digest authentication, WS authentication, user access log, 802.1x port based authentication						
	Protocols	IPv6, IPv4, HTTP, HTTPS, SOAP, DNS, NTP, RTSP, RTCP, RTP, TCP, UDP, IGMP, ICMP, DHCP, Zeroconf, ARP						
	Streaming Protocols	RTP/UDP, RTP/UDP multicast, RTP/RTSP/TCP, RTP/RTSP/HTTP/TCP, RTP/RTSP/HTTPS/TCP, HTTP						
	Device Management Protocols	SNMP v2c, SNMP v3						
PERIPHERALS	USB Port	USB 2.0						
	Onboard Storage	Dome	microSD/microSDHC/microSDXC slot – class 10/UHS-1 or better recommended					
	Bullet and Box	SD/SDHC/SDXC slot – class 10/UHS-1 or better recommended						

Specifications (Con't)

AUXILIARY I/O		Audio Compression Method	G.711 PCM 8 kHz		
		Audio Input/Output	Line level input and output		
		External I/O Terminals	Alarm In, Alarm Out		
		RS-485 Terminal	Yes, Box camera only		
MECHANICAL (DOME)			INDOOR SURFACE MOUNT	INDOOR IN-CEILING MOUNT	OUTDOOR SURFACE MOUNT
		Dimensions (LxWxH)	163 mm x 163 mm x 118 mm; 6.4" x 6.4" x 4.7"	181 mm x 181 mm x 164 mm; 7.1" x 7.1" x 6.5"	163 mm x 163 mm x 121 mm; 6.4" x 6.4" x 4.8"
		Weight	0.99 kg (2.18 lbs)	1.64 kg (3.62 lbs)	1.39 kg (3.06 lbs)
		Dome Bubble	Polycarbonate		
		Body	Plastic, Aluminum		Aluminum
		Housing	Surface mount, tamper resistant		Surface mount, vandal resistant
		Finish	Plastic, gray		Powder coat, RAL 9003
		Adjustment Range	360° pan, ±180° azimuth, 9° – 95° tilt (30° – 95° with -IR option)		
MECHANICAL (PENDANT DOME)			PENDANT CAMERA ONLY	WITH WALL MOUNT (H4A-MT-WALL1)	WITH NPT MOUNT (H4A-MT-NPTA1)
		Dimensions (LxWxH)	172 mm x 172 mm x 124 mm; 6.8" x 6.8" x 4.9"	275 mm x 172 mm x 152.1 mm; 10.8" x 6.8" x 6.0"	172 mm x 172 mm x 172.3 mm; 6.8" x 6.8" x 6.8"
		Weight	1.59 kg (3.51 lbs)	3.04 kg (6.70 lbs)	1.84 kg (4.06 lbs)
		Dome Bubble	Polycarbonate		
		Body	Aluminum		
		Housing	Pendant mount, vandal resistant		
		Finish	Powder coat, RAL 9003		
		Adjustment Range	360° pan, ±180° azimuth, 9° – 95° tilt (30° – 95° with -IR option)		
MECHANICAL (BULLET)		Dimensions (LxWxH)	280 mm x 126 mm x 91 mm; 11.04" x 4.97" x 3.58" (including mounting bracket)		
		Weight	Camera	1.71 kg (3.77 lbs)	
			Mounting Bracket	0.21 kg (0.46 lbs)	
		Body	Aluminum		
		Housing	Surface mount, tamper resistant		
		Finish	Powder coat, RAL 9003		
		Adjustment Range	±175° pan, ±90° tilt, ±175° azimuth		
MECHANICAL (BOX)		Dimensions (LxWxH)	168 mm x 76 mm x 67 mm; 6.6" x 3.0" x 2.6"		
		Weight	0.62 kg (1.4 lbs)		
		Body	Aluminum		
		Camera Mount	1/4"-20 UNC (top and bottom)		
		Finish	Powder coat, black		
ELECTRICAL					
		Power Consumption	Bullet	13 W max	
			Dome	13 W max (11 W with no IR or IR disabled)	
			Box	7 W max	
		Power Source	Bullet	VDC: 12 V ± 10%, 13 W min	VAC: 24 V ± 10%, 15 VA min
			Dome	VDC: 12 V ± 10%, 12 W min	VAC: 24 V ± 10%, 13 VA min
			Box	VDC: 12 V ± 10%, 7 W min	VAC: 24 V ± 10%, 9 VA min
		RTC Backup Battery	3V manganese lithium		
ENVIRONMENTAL					
		Operating Temperature	Bullet	-40 °C to +60 °C (-40 °F to 140 °F), in enclosed space	
			Dome	-40 °C to +65 °C (-40 °F to 149 °F), with ambient convection	
			Box	-10 °C to +60 °C (-14 °F to 140 °F)	
		IR Illuminator Behavior	Bullet	IR illuminator will turn off if the temperature is 61 °C (141 °F) or higher. The illuminator will operate at 50% power if the temperature is between 55 °C (131 °F) and 61 °C (141 °F). Hysteresis: 5 °C (9 °F).	
			Indoor Dome	IR illuminator will turn off if the temperature is 55 °C (131 °F) or higher. The illuminator will operate at 50% power if the temperature is between 44 °C (111 °F) and 55 °C (131 °F). Hysteresis: 2 °C (3.6 °F).	
			Outdoor Dome	IR illuminator will turn off if the temperature is 57 °C (135 °F) or higher. The illuminator will operate at 50% power if the temperature is between 49 °C (120 °F) and 57 °C (135 °F). Hysteresis: 2 °C (3.6 °F).	
		Storage Temperature	-10 °C to +70 °C (14 °F to 158 °F)		
		Humidity	0 - 95% non-condensing		
CERTIFICATIONS					
		Certifications/Directives	UL, cUL, CE, ROHS, Reach (SVHC), RCM, EAC, BIS, KC		
		Safety	UL 62368-1, CSA 62368-1, IEC/EN 62368-1, IEC 62471 (with -IR option)		
		Environmental	Bullet	UL/CSA/IEC 60950-22, IEC 60529 IP66 and IP67 Weather Rating, IEC 62262 IK10 Impact Rating	
			Outdoor Dome	UL/CSA/IEC 60950-22, IEC 60529 IP66 and IP67 Weather Rating, IEC 62262 IK10 Impact Rating	
		Electromagnetic Emissions	FCC Part 15 Subpart B Class B, IC ICES-003 Class B, EN 55032 Class B, EN 61000-6-3, EN 61000-3-2, EN 61000-3-3		
		Electromagnetic Immunity	EN 55024, EN 61000-6-1		

Outline Dimensions (Con't)

Surface Mount Outdoor Dome Camera (H5A-DO)

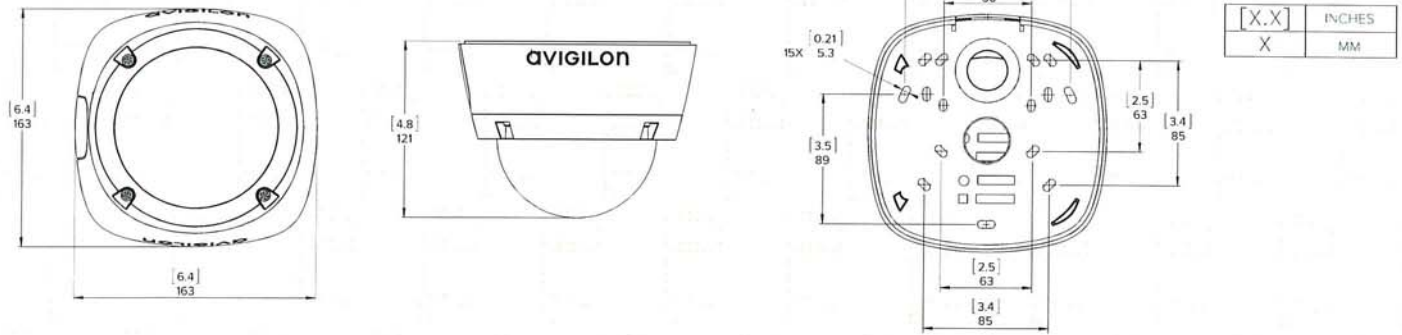

Pendant Dome Camera

(H5A-DP)
WITH NPT MOUNT (H4A-MT-NPTA1)

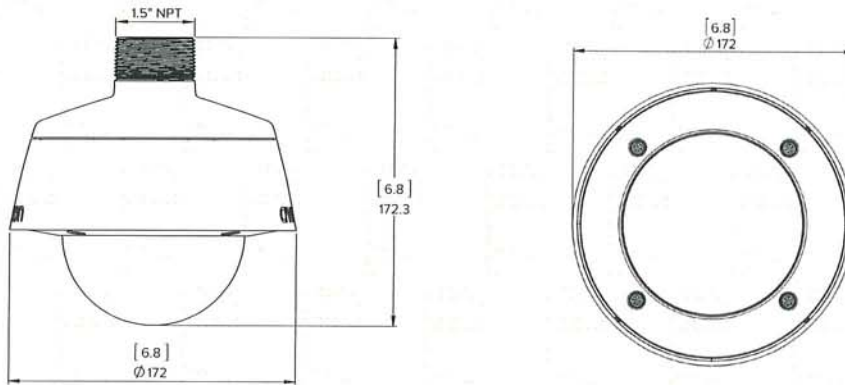

WITH WALL MOUNT (H4A-MT-WALL1)

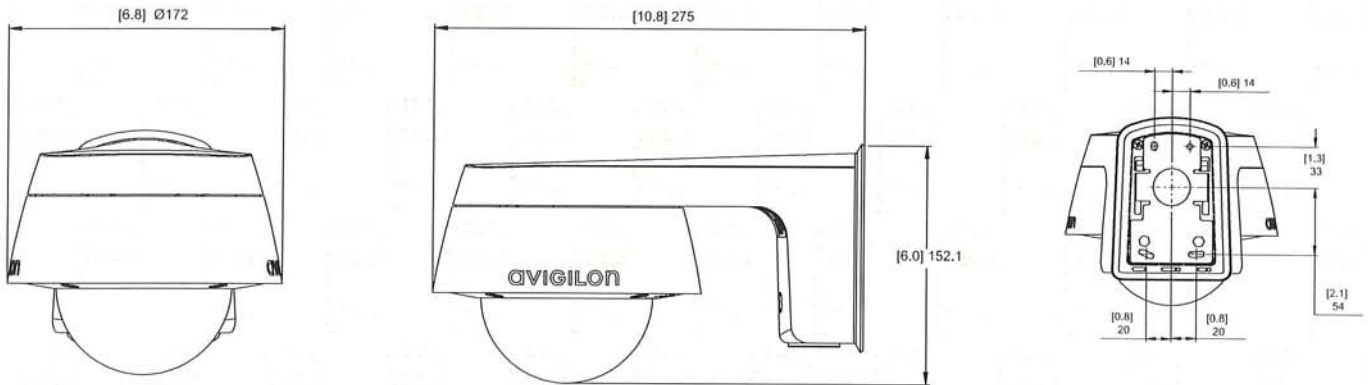

Box Camera

(H5A-B)

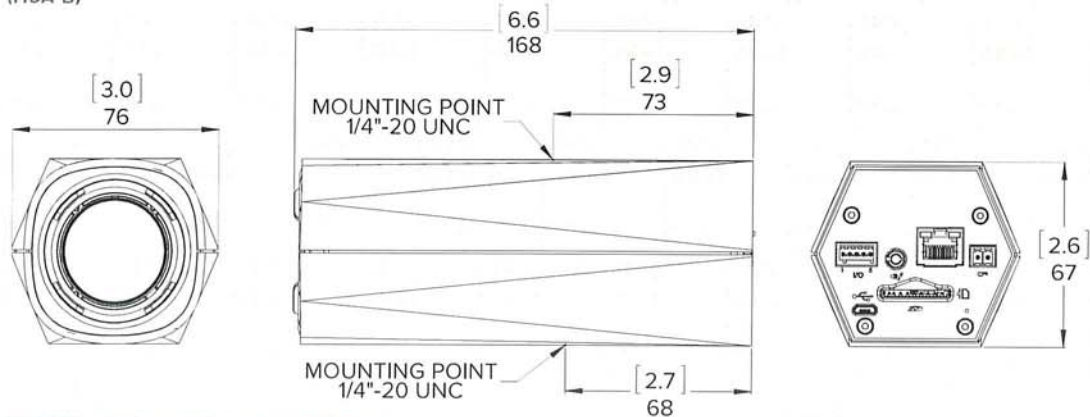

Outline Dimensions (Con't)

Bullet Camera

(H5A-BO-IR)

[X.X]	INCHES
X	MM

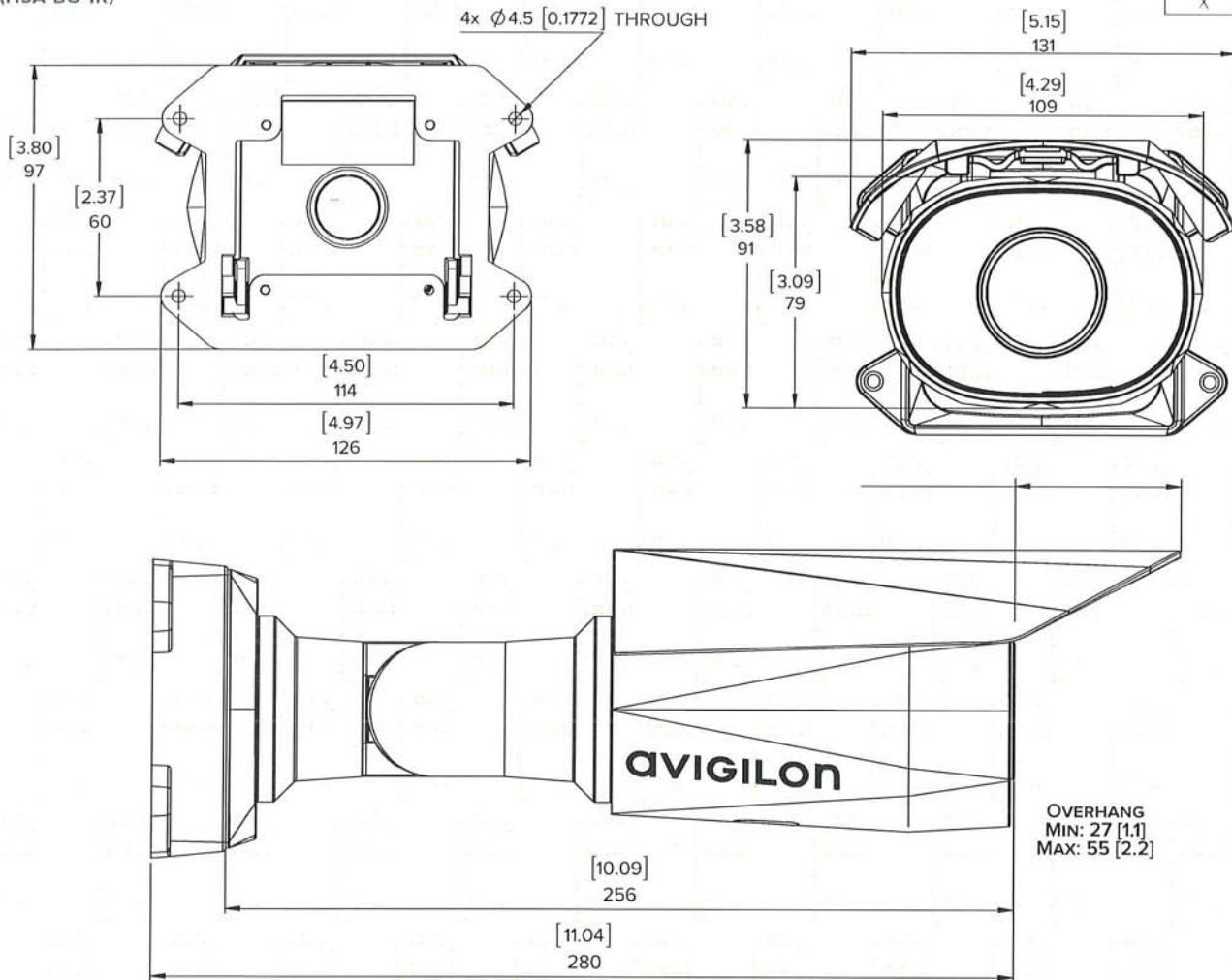

HD Bullet Camera Junction Box

(H4-BO-JBOX1)

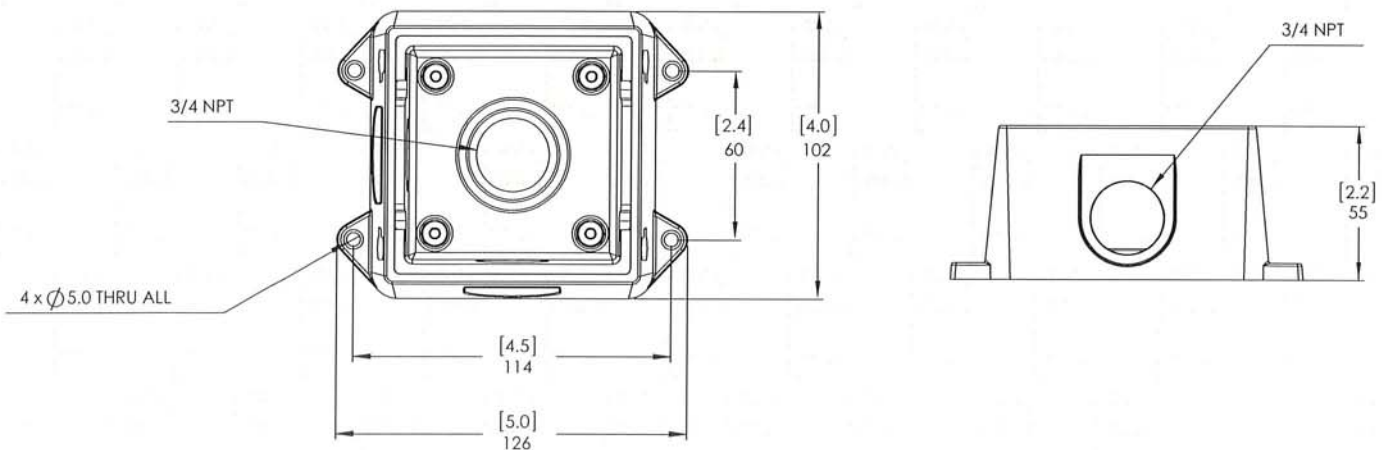

Ordering Information (Outdoor Dome and Bullet)

Surface Mount Outdoor Dome Camera

(H5A-DO)	MP	WDR	LightCatcher Technology	Lens	IR	Analytics	HDSM SmartCodec
2.0C-H5A-DO1	2.0	✓	✓	3.3 - 9 mm		✓	✓
2.0C-H5A-DO1HR	2.0	✓	✓	3.3 - 9 mm	✓	✓	✓
2.0C-H5A-DO2	2.0	✓	✓	9 - 22 mm		✓	✓
4.0C-H5A-DO1	4.0	✓	✓	3.3 - 9 mm		✓	✓
4.0C-H5A-DO1HR	4.0	✓	✓	3.3 - 9 mm	✓	✓	✓
4.0C-H5A-DO2	4.0	✓	✓	9 - 22 mm		✓	✓
5.0C-H5A-DO2	5.0	✓	✓	9 - 22 mm		✓	✓
6.0C-H5A-DO1	6.0	✓	✓	4.9 - 8 mm		✓	✓
6.0C-H5A-DO1HR	6.0	✓	✓	4.9 - 8 mm	✓	✓	✓
8.0C-H5A-DO1	8.0	✓	✓	4.9 - 8 mm		✓	✓
8.0C-H5A-DO1HR	8.0	✓	✓	4.9 - 8 mm	✓	✓	✓
H4A-DO-SMOK1	Outdoor dome camera cover with smoked bubble						
H4A-DO-CLER1	Outdoor dome camera cover with clear bubble						
H4A-AC-GROM1	Camera sealing grommet, pack of 10						
CM-AC-GROM1	Pipe grommet, pack of 10						
H4-AC-WIFI2-NA / H4-AC-WIFI2-EU	USB Wi-Fi adapter						
CM-AC-AVIO1	3.5 mm jack with 1.8 m fly wire						

Pendant Mount Outdoor Dome Camera

(H5A-DP)	MP	WDR	LightCatcher Technology	Lens	IR	Analytics	HDSM SmartCodec
2.0C-H5A-DP1	2.0	✓	✓	3.3 - 9 mm		✓	✓
2.0C-H5A-DP1HR	2.0	✓	✓	3.3 - 9 mm	✓	✓	✓
2.0C-H5A-DP2	2.0	✓	✓	9 - 22 mm		✓	✓
4.0C-H5A-DP1	4.0	✓	✓	3.3 - 9 mm		✓	✓
4.0C-H5A-DP1HR	4.0	✓	✓	3.3 - 9 mm	✓	✓	✓
4.0C-H5A-DP2	4.0	✓	✓	9 - 22 mm		✓	✓
5.0C-H5A-DP2	5.0	✓	✓	9 - 22 mm		✓	✓
6.0C-H5A-DP1	6.0	✓	✓	4.9 - 8 mm		✓	✓
6.0C-H5A-DP1HR	6.0	✓	✓	4.9 - 8 mm	✓	✓	✓
8.0C-H5A-DP1	8.0	✓	✓	4.9 - 8 mm		✓	✓
8.0C-H5A-DP1HR	8.0	✓	✓	4.9 - 8 mm	✓	✓	✓
H4A-DP-SMOK1	Pendant dome camera cover with smoked bubble						
H4A-DP-CLER1	Pendant dome camera cover with clear bubble						
H4A-MT-WALL1	Indoor/outdoor pendant wall arm mount						
H4A-MT-NPTA1	Indoor/outdoor pendant NPT mount						
H4-MT-POLE1	Aluminum pole mounting bracket for pendant dome cameras						
H4-MT-CRNR1	Aluminum corner mounting bracket for pendant dome cameras						
CM-AC-GROM1	Pipe grommet, pack of 10						
H4-AC-WIFI2-NA / H4-AC-WIFI2-EU	USB Wi-Fi adapter						
CM-AC-AVIO1	3.5 mm jack with 1.8 m fly wire						

Outdoor Bullet Camera

(H5A-BO-IR)	MP	WDR	LightCatcher Technology	Lens	IR	Analytics	HDSM SmartCodec
2.0C-H5A-BO1HR	2.0	✓	✓	3.3 - 9 mm	✓	✓	✓
2.0C-H5A-BO2-IR	2.0	✓	✓	9 - 22 mm	✓	✓	✓
4.0C-H5A-BO1HR	4.0	✓	✓	3.3 - 9 mm	✓	✓	✓
4.0C-H5A-BO2-IR	4.0	✓	✓	9 - 22 mm	✓	✓	✓
5.0C-H5A-BO2-IR	5.0	✓	✓	9 - 22 mm	✓	✓	✓
6.0C-H5A-BO1HR	6.0	✓	✓	4.9 - 8 mm	✓	✓	✓
8.0C-H5A-BO1HR	8.0	✓	✓	4.9 - 8 mm	✓	✓	✓
H4-BO-JBOX1	Junction box for bullet cameras						
H4-MT-POLE1	Aluminum pole mounting bracket for bullet cameras						
H4-MT-CRNR1	Aluminum corner mounting bracket for bullet cameras						
H4-AC-WIFI2-NA / H4-AC-WIFI2-EU	USB Wi-Fi adapter						

Ordering Information (Indoor Box and Dome)

Box Camera

(H5A-B)	MP	WDR	LightCatcher Technology	Lens	IR	Analytics	HDSM SmartCodec
2.0C-H5A-B1	2.0	✓	✓	4.7 - 84.6 mm		✓	✓
2.0C-H5A-B2	2.0	✓	✓	3.3 - 9 mm		✓	✓
4.0C-H5A-B2	4.0	✓	✓	3.3 - 9 mm		✓	✓
4.0C-H5A-B3	4.0	✓	✓	9 - 22 mm		✓	✓
6.0C-H5A-B2	6.0	✓	✓	4.9 - 8 mm		✓	✓
8.0C-H5A-B2	8.0	✓	✓	4.9 - 8 mm		✓	✓
H4-AC-WIFI2-NA / H4-AC-WIFI2-EU	USB Wi-Fi adapter						
CM-AC-AVIO1	3.5 mm jack with 1.8 m fly wire						

Surface Mount Indoor Dome Camera

(H5A-D)	MP	WDR	LightCatcher Technology	Lens	IR	Analytics	HDSM SmartCodec
2.0C-H5A-D1	2.0	✓	✓	3.3 - 9 mm		✓	✓
2.0C-H5A-D1HR	2.0	✓	✓	3.3 - 9 mm	✓	✓	✓
2.0C-H5A-D2	2.0	✓	✓	9 - 22 mm		✓	✓
4.0C-H5A-D1	4.0	✓	✓	3.3 - 9 mm		✓	✓
4.0C-H5A-D1HR	4.0	✓	✓	3.3 - 9 mm	✓	✓	✓
4.0C-H5A-D2	4.0	✓	✓	9 - 22 mm		✓	✓
6.0C-H5A-D1	6.0	✓	✓	4.9 - 8 mm		✓	✓
6.0C-H5A-D1HR	6.0	✓	✓	4.9 - 8 mm	✓	✓	✓
8.0C-H5A-D1	8.0	✓	✓	4.9 - 8 mm		✓	✓
8.0C-H5A-D1HR	8.0	✓	✓	4.9 - 8 mm	✓	✓	✓
H4A-DD-SMOK1	Indoor dome camera cover with smoked bubble						
H4A-DD-CLER1	Indoor dome camera cover with clear bubble						
H4A-DD-SMOK1-BL	Black indoor dome camera cover with smoked bubble						
H4A-DD-CLER1-BL	Black indoor dome camera cover with clear bubble						
H4A-DD-SDWL1	Indoor dome camera sidewall knockout plug, pack of 5						
H4A-DD-SDWL1-BL	Black indoor dome camera sidewall knockout plug, pack of 5						
H4-AC-WIFI2-NA / H4-AC-WIFI2-EU	USB Wi-Fi adapter						
CM-AC-AVIO1	3.5 mm jack with 1.8 m fly wire						

In-Ceiling Mount Indoor Dome Camera

(H5A-DC)	MP	WDR	LightCatcher Technology	Lens	IR	Analytics	HDSM SmartCodec
2.0C-H5A-DC1	2.0	✓	✓	3.3 - 9 mm		✓	✓
2.0C-H5A-DC1HR	2.0	✓	✓	3.3 - 9 mm	✓	✓	✓
2.0C-H5A-DC2	2.0	✓	✓	9 - 22 mm		✓	✓
4.0C-H5A-DC1	4.0	✓	✓	3.3 - 9 mm		✓	✓
4.0C-H5A-DC1HR	4.0	✓	✓	3.3 - 9 mm	✓	✓	✓
4.0C-H5A-DC2	4.0	✓	✓	9 - 22 mm		✓	✓
6.0C-H5A-DC1	6.0	✓	✓	4.9 - 8 mm		✓	✓
6.0C-H5A-DC1HR	6.0	✓	✓	4.9 - 8 mm	✓	✓	✓
8.0C-H5A-DC1	8.0	✓	✓	4.9 - 8 mm		✓	✓
8.0C-H5A-DC1HR	8.0	✓	✓	4.9 - 8 mm	✓	✓	✓
H4A-DC-SMOK1	In-ceiling dome camera cover with smoked bubble						
H4A-DC-CLER1	In-ceiling dome camera cover with clear bubble						
H4A-DC-SMOK1-BL	Black in-ceiling dome camera cover with smoked bubble						
H4A-DC-CLER1-BL	Black in-ceiling dome camera cover with clear bubble						
H4-DC-CPNL1	Metal ceiling panel						
H4A-AC-GROM1	Camera sealing grommet, pack of 10						
H4-AC-WIFI2-NA / H4-AC-WIFI2-EU	USB Wi-Fi adapter						
CM-AC-AVIO1	3.5 mm jack with 1.8 m fly wire						



Installation Guide

Avigilon Network Video Recorder

HD-NVR3-VAL-3TB, HD-NVR3-VAL-6TB, HD-NVR3-VAL-12TB
and HD-NVR3-VAL-18TB

© 2016 - 2019, Avigilon Corporation. All rights reserved. AVIGILON, the AVIGILON logo, AVIGILON CONTROL CENTER and AVIGILON APPEARANCE SEARCH are trademarks of Avigilon Corporation. Other names or logos mentioned herein may be the trademarks of their respective owners. The absence of the symbols ™ and ® in proximity to each trademark in this document or at all is not a disclaimer of ownership of the related trademark. Avigilon Corporation protects its innovations with patents issued in the United States of America and other jurisdictions worldwide (see avigilon.com/patents). Unless stated explicitly and in writing, no license is granted with respect to any copyright, industrial design, trademark, patent or other intellectual property rights of Avigilon Corporation or its licensors.

This document has been compiled and published using product descriptions and specifications available at the time of publication. The contents of this document and the specifications of the products discussed herein are subject to change without notice. Avigilon Corporation reserves the right to make any such changes without notice. Neither Avigilon Corporation nor any of its affiliated companies: (1) guarantees the completeness or accuracy of the information contained in this document; or (2) is responsible for your use of, or reliance on, the information. Avigilon Corporation shall not be responsible for any losses or damages (including consequential damages) caused by reliance on the information presented herein.

Avigilon Corporation
avigilon.com

PDF-NVR3VAL-A

Revision: 4 - EN

20191031

Table of Contents

Introduction	1
Before You Start	1
Overview	1
Front View	1
Back View	2
Installation	3
Package Contents	3
Installing the Rack Rails and Cable Management Arm	3
Connecting Cables	3
Installing the Bezel	3
Configuring Windows 10	4
Troubleshooting	4
Network Configuration	4
Operating System Recovery By Avigilon Recovery Partition	4
Operating System Recovery By External USB	6
LED Indicators	7
Power Status Indicators	7
Network Link Status Indicators	7
Hard Drive RAID Status Indicators	8
Advanced Features	10
Checking System Health	10
Replacing Hard Drives	11
Specifications	12

Introduction

The Avigilon Network Video Recorder is preloaded with the Avigilon Control Center software and is configured for maximum performance and reliability. The Network Video Recorder can be easily integrated into any existing Avigilon security system, or act as the base of a new site.

Before You Start

Avigilon recommends the use of an uninterruptible power supply (UPS) system to protect your video surveillance system hardware. A UPS system is used to protect critical equipment from mains supply problems, including spikes, voltage dips, fluctuations and complete power failures using a dedicated battery. It can also be used to power equipment during the time it takes for a standby generator to be started and synchronized.

Any UPS connection must include configuration to shut down the Windows operating system on the appliance when battery power is low or there is 15 minutes of power remaining.

It is recommended that cameras not be connected to the appliance until after the appropriate network configuration has been set up.

Overview

Front View

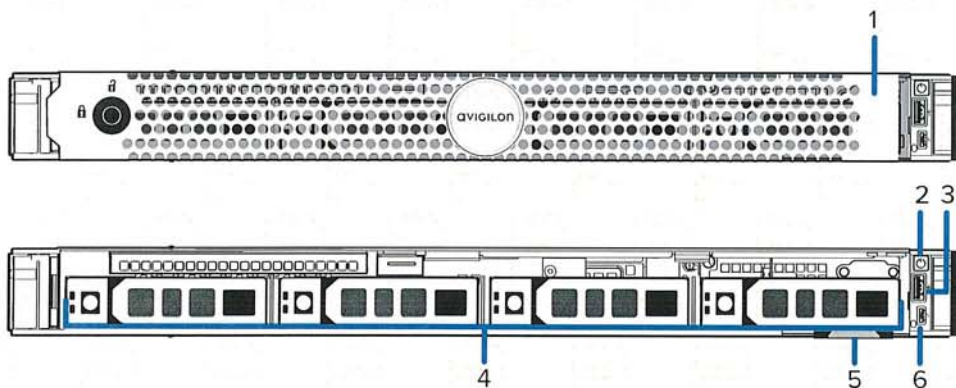

1. **Bezel**

Protects against unauthorized physical access to the hard drives. The bezel must be removed to access the front of the recorder.

2. **Power button**

Controls the power supply to the recorder.

3. **Video connector**

Accepts a VGA monitor connection.

4. **LCD display**

Provides information about system information and error messages. For details about the error messages, see the *Dell Event and Error Messages Reference Guide*.

5. **USB connectors**

Accepts USB connections to external devices.

6. **Information tag**

Provides the product service details, MAC addresses and a copy of the Windows license key.

7. **Hard drives**

Provides access to hot-swappable hard drives. There are LED indicators on each hard drive.

Back View

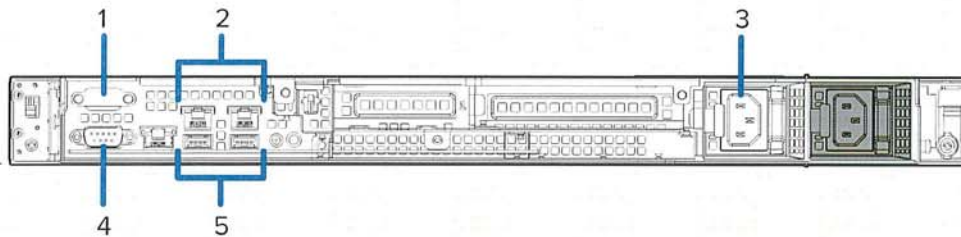

1. **Serial connector**

Accepts connections to serial devices.

2. **1 Gigabit Ethernet ports**

Accepts an Ethernet connection to multiple networks.

3. **Power supply**

Redundant power supply.

Optional secondary power supply is available (HD-NVR3-VAL-2NDPS-NPC).

4. **Video connector**

Accepts a VGA monitor connection.

5. **USB connectors**

Accepts USB connections to external devices.

Installation

Package Contents

Ensure the package contains the following:

- Avigilon Network Video Recorder
- Rack sliding rail assembly kit
- Cable management arm assembly kit
- Bezel and key
- Power cable
- Recovery USB — contains Windows recovery software and supporting materials.

Installing the Rack Rails and Cable Management Arm

If the recorder will be kept in a server rack, install the Rack Sliding Rails and the Cable Management Arm provided in the recorder package. Follow the procedures outlined in the *Rack Installation Instructions* and the *CMA Installation Instructions* provided in the assembly kits.

Note: The supplied Rack Sliding Rails are compatible with square and round hole racks.

Connecting Cables

Refer to the diagrams in the Overview section for the location of the different connectors. Make the following connections as required:

1. Connect a KVM switch or separate keyboard, mouse and monitor to the recorder.
 - The keyboard and mouse can be connected to any USB port on the recorder.
 - The monitor can be connected to any video connector at the front or back of the recorder.
2. Connect the recorder to your network using an Ethernet cable.
3. Connect a power cable to the power supply at the back of the recorder.
4. Press the power button on the front of the recorder. Check that the recorder LED indicators display the correct status.

Installing the Bezel

The bezel can be installed on the front of the recorder to help protect the power button and hard drives against unauthorized access.

1. Slide the right end of the bezel against the right hinge of the recorder.
2. Push the left end of the bezel against the recorder until it clicks into place.
3. Use the provided key to lock the bezel.

Configuring Windows 10

When you start the Video Appliance for the first time, you will need to configure the Windows operating system that is installed on the appliance.

After the recorder starts, you will need to configure the Windows operating system for the first time.

1. On the first screen, the MICROSOFT SOFTWARE LICENSE TERMS and AVIGILON CONTROL CENTER™ SOFTWARE END USER LICENSE AGREEMENT are displayed. Review the terms and click **Accept**.
2. Select **Join a local Active Directory domain**.

Note: This prompt appears only if an Active Directory is present on the network. See the *Windows Help and Support* files for more information.

3. Enter a user name for accessing the Windows software.
4. Enter a password and password hint for the user name and click **Next**.

Proceed to activate the license for the Avigilon Control Center software on your Network Video Recorder.

Troubleshooting

Network Configuration

By default, the ACC ES 8 Port Appliance acquires an IP address on the network through DHCP. If you need to set up the ACC ES 8 Port Appliance to use a static IP address or any specific network configuration, see the *Windows Help and Support* files for more information.



By default, the Network Video Recorder acquires an IP address on the network through DHCP. If you need to set up the recorder to use a static IP address or any specific network configuration, see the *Windows Help and Support* files for more information.

Operating System Recovery By Avigilon Recovery Partition

If you need to recover the Windows operating system, the includes an onboard Avigilon recovery partition that is separate from the operating system partition. The advantage of using the Avigilon recovery partition is that you do not need an internet connection.

Important: Your operating system drive will be erased and restored to factory settings. Before you proceed with operating system recovery, complete any necessary backups of custom ACC configuration and video recordings. For more information about ACC software backups, see <http://avigilon.com/recovery>.

Note: Depending on when your was shipped, it is recommended that you connect to the network when possible to install updates for Windows and ACC Client software after system recovery is completed. For more information about ACC software installations, see <http://avigilon.com/recovery>.

1. Start operating system recovery in one of the following ways:
 - On your Windows desktop, select  and then hold down the Shift key and select **Restart**.
 - On your locked Windows screen, select  and then hold down the Shift key and select **Restart**.
 - During direct boot of the operating system, repeatedly press the down-arrow key and select the partition.
2. On the **Choose an option** screen, select **Use another operating system**.
3. Select the **OS Recovery** partition.
4. On the **Avigilon Recovery** window, select **Recover**.

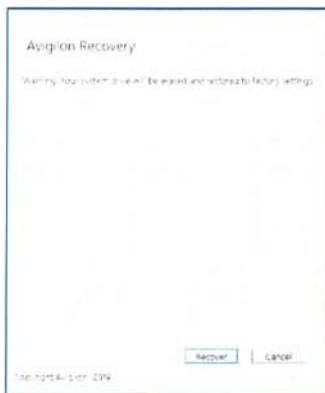

Allow up to half an hour for the recovery to complete.

5. After system reboot, complete the Windows setup process. For more information, see *Configuring Windows 10* on the previous page.
6. Navigate to `C:\Avigilon\Control Center Installation Files`, and run the ACC installer for the version of ACC software in use at your site.

Operating System Recovery By External USB

If you need to recover the Windows operating system on the and you have access to the internet, it is recommended that you download the latest Avigilon Recovery Image from <http://avigilon.com/recovery> and refer to Support and Downloads for the following information:

- Minimum size of the USB recovery device
- Creating an external USB recovery device
- Recovering the operating system from an external USB recovery device

The general steps are:

1. Load the Avigilon Recovery Image onto a USB recovery device.
2. Plug the USB recovery device into the workstation.
3. Repeatedly press the F12 key while booting the workstation.
4. On the UEFI Boot menu, select the USB recovery device.

LED Indicators

The following tables describe what the LEDs on the recorder indicate.

Power Status Indicators

The power button on the front of the recorder lights up when power is on.

Additional information about the power supply is provided by the power status indicator on the back of the recorder. The following table describes what the LEDs indicate:

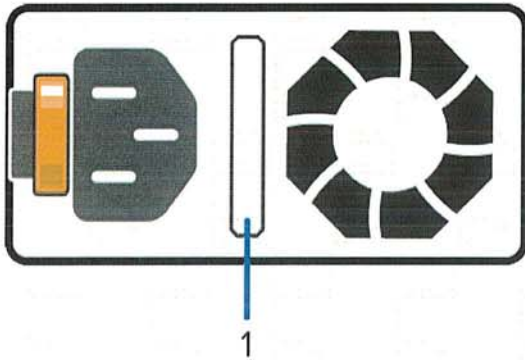

Figure 1: (1) The power status indicator.

LED Indicator	Description
Off	Power is not connected.
Green	Power is supplied to the recorder.
Flashing green	Firmware update is being applied to the power supply unit.
Flashing green then turns off	The redundant power supply is mismatched. This only occurs if you have a secondary redundant power supply installed.
Flashing orange	There is a problem with the power supply.

Network Link Status Indicators

When the recorder is connected to the network, the recorder's connection status LEDs above the Ethernet port display the recorder's connection status to the network. The following table describes what the LEDs indicate:

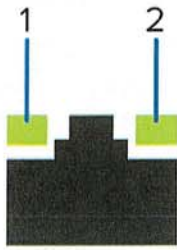

Figure 2: (1) Link LED, (2) Connection Status LED.

LED Indicator	Description
Off	The recorder is not connected to a network.
Link LED is green	The recorder is connected to a network at the maximum port speed (1 Gbps or 10 Gbps).
Link LED is orange	The recorder is connected to a network at less than the maximum port speed.
Connection Status LED is blinking green	The recorder is working with other parts of the Avigilon Control Center software.

Hard Drive RAID Status Indicators

Each hard drive has its own set of LED indicators to show its activity and status.

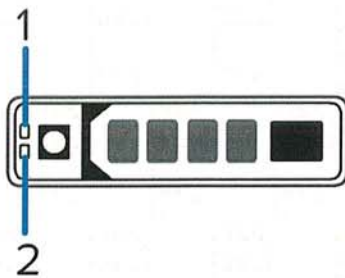

Figure 3: (1) Status LED, (2) Activity LED.

The Activity LED flashes green when the hard drives are working. The following table describes what the Status LEDs indicate:

LED Indicator	Description
Green	The hard drive is online.
Off	The hard drive is disconnected from the recorder.
Two short green flashes every second	The system is identifying a new hard drive, or preparing a hard drive for removal.
Flashes green, orange then off	The hard drive is predicted to fail.
Four short orange flashes per second	The hard drive has failed.
Flashes green slowly	The hard drive is rebuilding.

LED Indicator	Description
Blinks green for three seconds, orange for three seconds and off for six seconds	The hard drive rebuild has been aborted.

Advanced Features

Checking System Health

The Server Administrator software is pre-installed on the recorder. The software provides information about the recorder's system operation status, and gives you remote access to the recorder for recovery operations.





If one of the LED indicators on the recorder is flashing an error warning, the Server Administrator will display details about the problem. For more information about the LED indicators, see *LED Indicators* on page 7.

1. Open the Server Administrator.
 - To open the Server Administrator locally, double-click the **Server Administrator** shortcut icon on the desktop.
 - To open the Server Administrator remotely, open a web browser and enter this address:
`https://<recorder IP Address>:1311/`.

For example: `https://192.168.1.32:1311/` or `https://localhost:1311/`.

If you are using an intranet connection, your browser may display an error message. Allow the browser to ignore the certificate warnings.

2. If asked to log in, enter the Windows software administrator username and password that was configured for the recorder.
3. On the Server Administrator home page, the health of the system components are displayed in the workspace on the right.
 - To see the health of other system components, expand and select a different component from the System Tree on the left.
 - The table displayed in the workspace lists system components and their status:

	The system component is running normally.
	The system component has a non-critical warning.
	The system component has a critical failure.
	The system component status is unknown.
 - To see the details of a system component, select the system component from the workspace.

The Server Administrator is also used to customize the Redundant Array of Independent Disks (RAID) settings, assign a hot spare and remotely monitor the system health. For more information about the features in the Server Administrator, see the Help system provided in the software.

Replacing Hard Drives

1. Locate the failed hard drive at the front or back of the recorder.

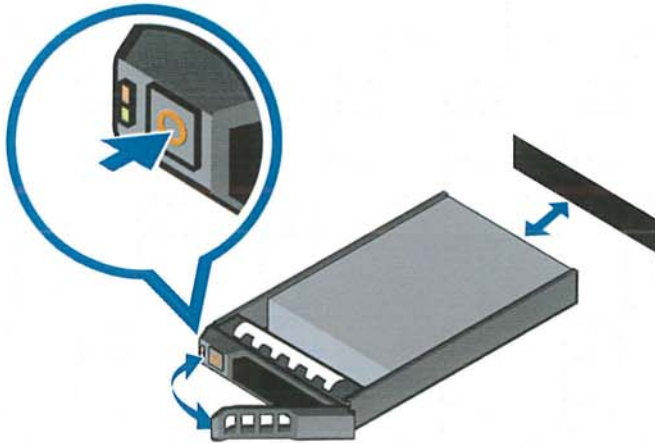

2. Press the release button on the front left of the hard drive.
3. When the handle is released, pull the hard drive out of the recorder.
4. Remove the four screws from the side of the hard drive carrier.
5. Lift the failed hard drive out of the carrier.
6. Insert a new hard drive into the carrier then screw it into place. The hard drive connectors should face the back.
7. When the hard drive is secured in the carrier, insert the hard drive back into the recorder.
8. Once the hard drive is inserted all the way in, push the handle against the hard drive to lock it into place.

The recorder immediately starts rebuilding the hard drive. The progress is displayed in the Server Administrator. This may take several hours.

Specifications

System	
Avigilon Control Center Software	Enterprise, Standard and Core
Operating System	Windows 10 Enterprise 2016 LTSB
Hard Disk Drive Configuration	Near-line SAS, hot swappable, RAID 5
Mechanical	
Dimensions (H x W x D)	42.95 mm x 482.4 mm x 674.7 mm (1.69 in. x 18.99 in. x 26.56 in.)
Weight	13.8 kg (30.42 lb)
Form Factor	1U rack
Electrical	
Power Input	100 to 240 V AC, 50/60 Hz, autoranging
Power Consumption	350 W (1194.2 BTU/hr)
Power Supply	Single — optional secondary power supply (HD-NVR3-VAL-2NDPS-NPC)
Environmental	
Operating Temperature	10 °C to 35 °C (50 °F to 95 °F) with no direct sunlight on the equipment.
Storage Temperature	-40 °C to 65 °C (-40 °F to 149 °F)
Operating Humidity	10% to 80% Relative Humidity with 29°C (84.2°F) maximum dew point.
Storage Humidity	5% to 95% RH with 33°C (91°F) maximum dew point. Atmosphere must be non-condensing at all times.
Operating Vibration	0.26 Grms at 5 Hz to 350 Hz
Storage Vibration	1.88 Grms at 10 Hz to 500 Hz for 15 min
Operating Shock	Six consecutively executed shock pulses in the positive and negative x, y, and z axes of 40 G for up to 2.3 ms.
Storage Shock	Six consecutively executed shock pulses in the positive and negative x, y, and z axes (one pulse on each side of the system) of 71 G for up to 2 ms.
Operating Altitude	3,048 m (10,000 ft).

Storage Altitude	12,000 m (39,370 ft)
Certifications	
Safety	EN 60950-1:2006 / A11:2009 / A1:2010 / A12:2011 / A2:2013 UL/CSA/IEC 60950-1, 2 Ed + Am 1: 2009 + Am 2: 2013 EN 62311:2008
Power Efficiency	80 PLUS Titanium ENERGY STAR 2.0
Electromagnetic Emissions	EN 55032:2012+AC2011/CISPR 22:2008 EN 61000-3-2:2006 + A1:2009 + A2:2009/IEC 61000-3-2:2005 + A1:2008 + A2:2009 (Class A) EN 61000-3-3:2013/IEC 61000-3-3:2013
Electromagnetic Immunity	EN 55024:2010/CISPR 24:2010
Directives	RoHS, Reach (SVHC), WEEE

Limited Warranty and Technical Support

Avigilon warranty terms for this product are provided at avigilon.com/warranty.

Warranty service and technical support can be obtained by contacting Avigilon Technical Support: avigilon.com/contact-us/.



avigilonTM
a Motorola Solutions Company

✓ **GENDER: FEMALE**

✓ **UPPER BODY COLOR: RED**

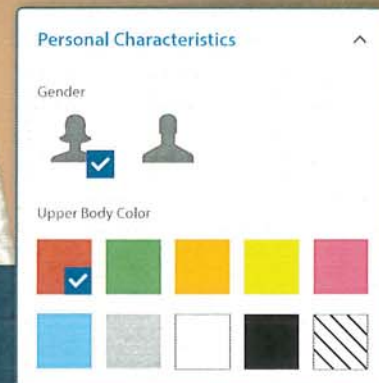

Appearance Search

Search Made Simple

Avigilon Appearance Search™ video analytics technology is a sophisticated deep learning AI search engine for video. It sorts through hours of video with ease, to quickly locate a specific person or vehicle of interest. Appearance Search can improve incident response time and enhance forensic investigations by helping operators compile robust video evidence, create a powerful narrative of events, and reveal a vehicle or individual's route or last-known location.

Integrated Solution

Integrated with Avigilon Control Center (ACC) 7 and ACC™ 6 Enterprise edition software, Avigilon cameras with self-learning video analytics and select Avigilon Network Video Recorders (NVRs).

Initiate Searches Based on Physical Descriptions

Allows operators to search for a person by selecting certain specific physical descriptions, including clothing color, gender and age categorization.

Search Across Multiple Sites

Initiate a search for a person or vehicle of interest across one site, then continue the search for the same subject of interest by seamlessly transitioning from one site to the next site that uses the same version of ACC software.



Face Analytics Included in Search

Incorporating the unique characteristics of a person's face enables the Appearance Search technology to understand that it is searching for the same person, even if items such as their clothing change over time.

Playback, Bookmark and Export Tools

Build a comprehensive set of video evidence from multiple video sources, to create a powerful narrative of events.

avigilon.com/appearance-search | asksales@avigilon.com

Two Ways to Build Your Avigilon AI-Powered Solution

1 Avigilon Integrated Solution

Enable Appearance Search by combining Avigilon H4 cameras with self-learning video analytics with our NVRs that are pre-loaded and pre-configured with ACC software.



2 ONVIF®-Compliant Solution

Evolve your legacy Avigilon and third-party ONVIF-compliant camera systems with the Avigilon AI Appliance, adding patented self-learning video analytics and Appearance Search when connected to ACC 7 or ACC 6 software.



avigilon.com/ai-appliance | avigilon.com/nvr | asksales@avigilon.com

NVR3 Value requires an additional kit to enable Avigilon Appearance Search technology.

Product features and functionalities may not yet be available and, if and when available, may not be as depicted. Images have been simulated for illustrative purposes.

© 2019 Avigilon Corporation. All rights reserved. AVIGILON, the AVIGILON logo, AVIGILON CONTROL CENTER, ACC, and AVIGILON APPEARANCE SEARCH are trademarks of Avigilon Corporation. ONVIF is a trademark of Onvif, Inc. Other names or logos mentioned herein may be the trademarks of their respective owners.