

TIPS VENDOR AGREEMENT

Between C/S Sewer Equipment Co. Inc. and
(Company Name)

THE INTERLOCAL PURCHASING SYSTEM (TIPS),
a Department of Texas Education Service Center Region 8 for
TIPS RFP 191001 Heavy Duty Equipment

General Information

The Vendor Agreement ("Agreement") made and entered into by and between The Interlocal Purchasing System (hereinafter referred to as "TIPS" respectfully) a government cooperative purchasing program authorized by the Region 8 Education Service Center, having its principal place of business at 4845 US Hwy 271 North, Pittsburg, Texas 75686. This Agreement consists of the provisions set forth below, including provisions of all Attachments referenced herein. In the event of a conflict between the provisions set forth below and those contained in any Attachment, the provisions set forth shall control unless otherwise agreed by the parties in writing and by signature and date on the attachment.

A Purchase Order, Agreement or Contract is the TIPS Member's approval providing the authority to proceed with the negotiated delivery order under the Agreement. Special terms and conditions as agreed between the Vendor and TIPS Member should be added as addendums to the Purchase Order, Agreement or Contract. Items such as certificate of insurance, bonding requirements, small or disadvantaged business goals are some, but not all, of the addendums possible.

Terms and Conditions

Freight

All quotes to members shall provide a line item for cost for freight or shipping regardless if there is a charge or not. If no charge for freight or shipping, indicate by stating "No Charge" or "\$0", "included in price" or other similar indication. Otherwise, all shipping, freight or delivery charges shall be passed through to the TIPS Member at cost with no markup and said charges shall be agreed by the TIPS Member unless alternative shipping terms are agreed by TIPS as a result of the proposal award.

Warranty Conditions

All new supplies equipment and services shall include ***manufacturer's minimum standard warranty*** unless otherwise agreed to in writing. Vendor shall be legally permitted to sell all products offered for sale to TIPS Members if the offering is included in the Request for Proposal category. All goods proposed and sold shall be new unless clearly stated in writing.

Customer Support

The Vendor shall provide timely and accurate customer support for orders to TIPS Members as agreed by the Parties. Vendors shall respond to such requests within a commercially reasonable time after receipt of the request. If support and/or training is a line item sold or packaged with a sale, support shall be as agreed with the TIPS Member.

Agreements

Agreements for purchase will normally be put into effect by means of a purchase order(s) executed by authorized agents of the TIPS Member participating government entities, but other means of placing an order may be used at the Member's discretion.

Tax exempt status

Most TIPS Members are tax exempt and the related laws and/or regulations of the controlling jurisdiction(s) of the TIPS Member shall apply.

Assignments of Agreements

No assignment of this Agreement may be made without the prior notification of TIPS. Written approval of TIPS shall not be unreasonably withheld. Payment for delivered goods and services can only be made to the awarded Vendor, Vendor designated reseller or vendor assigned company.

Disclosures

- Vendor and TIPS affirms that he/she or any authorized employees or agents has not given, offered to give, nor intends to give at any time hereafter any economic opportunity, future employment, gift, loan, gratuity, special discount, trip, favor or service to a public servant in connection with this Agreement.
- Vendor shall attach, in writing, a complete description of any and all relationships that might be considered a conflict of interest in doing business with the TIPS program.
- The Vendor affirms that, to the best of his/her knowledge, the offer has been arrived at independently, and is submitted without collusion with anyone to obtain information or gain any favoritism that would in any way limit competition or give an unfair advantage over other vendors in the award of this Agreement.

Term and Renewal of Agreements

The Agreement with TIPS is for three (3) years with an option for renewal for an additional one (1) consecutive year if both parties agree. TIPS may or may not exercise the one-year extension beyond the base three-year term and whether or not to offer the extension is at the sole discretion of TIPS. The scheduled Agreement termination date shall be the last date of the month of the last month of the agreement's legal effect. **Example:** *If the agreement is scheduled to end on May 23, the anniversary date of the award, it would actually be extended to May 31 in the last month of the last year the contract is active.*

Automatic Renewal Clauses Incorporated in Awarded Vendor Agreements with TIPS Members Resulting from the Solicitation and with the Vendor Named in this Agreement.

No Agreement for goods or services with a TIPS Member by the awarded vendor named in this Agreement that results from the solicitation award named in this Agreement, may incorporate an automatic renewal clause that exceeds month to month terms with which the TIPS Member must comply. All renewal terms incorporated in an Agreement by the vendor with the TIPS Member shall only be valid and enforceable when the vendor receives written confirmation by purchase order, executed Agreement or other written instruction issued by the TIPS Member for any renewal period. The purpose of this clause is to avoid a TIPS Member inadvertently renewing an Agreement during a period in which the governing body of the TIPS Member has not properly appropriated and budgeted the funds to satisfy the Agreement renewal. This term is not negotiable and any Agreement between a TIPS Member and a TIPS awarded vendor with an automatic renewal clause that conflicts with these terms is rendered void and unenforceable.

Shipments

The Vendor shall ship, deliver or provide ordered products or services within a commercially reasonable time after the receipt of the order from the TIPS Member. If a delay in said delivery is anticipated, the Vendor shall notify TIPS Member as to why delivery is delayed and shall provide an estimated time for completion of the order. TIPS or the requesting entity may cancel the order if estimated delivery time is not acceptable or not as agreed by the parties.

Invoices

Each invoice or pay request shall include the TIPS Member's purchase order number or other identifying designation as provided in the order by the TIPS Member. If applicable, the shipment tracking number or pertinent information for verification of TIPS Member receipt shall be made available upon request.

Payments

The TIPS Member will make payments directly to the Vendor, the vendor assigned dealer or as agreed by the Vendor and the TIPS Member after receiving invoice and in compliance with applicable payment statute(s), whichever is the greater time or as otherwise provided by an agreement of the parties.

Pricing

Price increases will be honored according to the terms of the solicitation. All pricing submitted to TIPS shall include the participation fee, as provided in the solicitation, to be remitted to TIPS by the Vendor. Vendor will not show adding the fee to the invoice presented to TIPS Member customer.

Participation Fees

The Participation Fee that was published as part of the Solicitation and the fee published is the legally effective fee, along with any fee conditions stated in the RFP. Collection of the fees by TIPS is required under Texas Government Code §791.011 Et seq. Vendor or vendor assigned dealer agrees to pay the participation fee for all Agreement sales to TIPS on a monthly scheduled report or as otherwise agreed by the parties. To report sales, login to the TIPS Vendor Portal and click on the PO's and Payments tab. Pages 3-7 of the Vendor Portal User Guide will walk you through the process of reporting sales to TIPS. Please refer to the TIPS Accounting FAQ's for more information about reporting sales and if you have further questions, contact the Accounting Team at accounting@tips-usa.com. The Vendor or vendor assigned dealers are responsible for keeping record of all sales that go through the TIPS Agreement and submitting same to TIPS. Failure to render the participation fee to TIPS shall constitute a breach of this agreement with our parent governmental entity, Texas Education Service Center Region 8, as established by the Texas legislature and shall be grounds for termination of this agreement and any other agreement held with TIPS and possible legal action. TIPS reserves all rights under the law to collect the fees due. Please contact TIPS at tips@tips-usa.com or call (866) 839-8477 if you have questions about paying fees.

Indemnity

The Vendor agrees to indemnify and hold harmless and defend TIPS, TIPS Member(s), officers and employees from and against all claims and suits by third parties for damages, injuries to persons (including death), property damages, losses, and expenses including court costs and reasonable attorney's fees, arising out of, or resulting from, Vendor's performance under this Agreement, including all such causes of action based upon common, constitutional, or statutory law, or based in whole or in part, upon allegations of negligent or intentional acts on the part of the Vendor, its officers, employees, agents, subcontractors, licensees, or invitees. Parties found liable shall pay their proportionate share of damages as agreed by the parties or as ordered by a court of competent jurisdiction over the case. **NO LIMITATION OF LIABILITY FOR DAMAGES FOR PERSONAL INJURY OR PROPERTY DAMAGE ARE PERMITTED OR AGREED BY TIPS/ESC REGION 8.** Per Texas Education Code §44.032(f), and pursuant to its requirements only, reasonable Attorney's fees are recoverable by the prevailing party in any dispute resulting in litigation.

State of Texas Franchise Tax

By signature hereon, the bidder hereby certifies that he/she is not currently delinquent in the payment of any franchise taxes owed the State of Texas under Chapter 171, Tax Code.

Miscellaneous

The Vendor acknowledges and agrees that continued participation in TIPS is subject to TIPS sole discretion and that any Vendor may be removed from the participation in the Program at any time with or without cause. Nothing in the Agreement or in any other communication between TIPS and the Vendor may be construed as a guarantee that TIPS or TIPS Members will submit any orders at any time. TIPS reserves the right to request additional proposals for items or services already on Agreement at any time.

Purchase Order Pricing/Product Deviation

If a deviation of pricing/product on a purchase order or contract modification occurs between the Vendor and the TIPS Member, TIPS must be notified within five (5) business days of receipt of change order.

Termination for Convenience of TIPS Agreement Only

TIPS reserves the right to terminate this agreement for cause or no cause for convenience with a thirty (30) days prior written notice. Termination for convenience is conditionally required under Federal Regulations 2 CFR part 200 if the customer is using federal funds for the procurement. All purchase orders presented to the Vendor, but not fulfilled by the Vendor, by a TIPS Member prior to the actual termination of this agreement shall be honored at the option of the TIPS Member. The awarded vendor may terminate the agreement with ninety (90) days prior written notice to TIPS 4845 US Hwy North, Pittsburg, Texas 75686. The vendor will be paid for goods and services delivered prior to the termination provided that the goods and services were delivered in accordance with the terms and conditions of the terminated agreement. This termination clause does not affect the sales agreements executed by the Vendor and the TIPS Member customer pursuant to this agreement. TIPS Members may negotiate a termination for convenience clause that meets the needs of the transaction based on applicable factors, such as funding sources or other needs.

TIPS Member Purchasing Procedures

Usually, purchase orders or their equal are issued by participating TIPS Member to the awarded vendor and should indicate on the order that the purchase is per the applicable TIPS Agreement number. Orders are typically emailed to TIPS at tips@tips-usa.com.

- Awarded vendor delivers goods/services directly to the participating member.
- Awarded vendor invoices the participating TIPS Member directly.
- Awarded vendor receives payment directly from the participating member.
- Awarded vendor reports sales monthly to TIPS (unless prior arrangements have been made with TIPS for an alternative submission schedule).

Licenses

Awarded vendor shall maintain, in current status, all federal, state and local licenses, bonds and permits required for the operation of the business conducted by awarded vendor. Awarded vendor shall remain reasonably fully informed of and in compliance with all ordinances and regulations pertaining to the lawful

provision of goods or services under the Agreement. TIPS and TIPS Members reserves the right to stop work and/or cancel an order or terminate this or any other sales Agreement of any awarded vendor whose license(s) required for performance under this Agreement have expired, lapsed, are suspended or terminated subject to a 30-day cure period unless prohibited by applicable statute or regulation.

Novation

If awarded vendor sells or transfers all assets, rights or the entire portion of the assets or rights required to perform this Agreement, a successor in interest must guarantee to perform all obligations under this Agreement. A simple change of name agreement will not change the Agreement obligations of awarded vendor. TIPS will consider Contract Assignments on a case by case basis. TIPS must be notified within five (5) business days of the transfer of assets or rights.

Site Requirements (only when applicable to service or job)

Cleanup: When performing work on site at a TIPS Member's property, awarded vendor shall clean up and remove all debris and rubbish resulting from their work as required or directed by TIPS Member or as agreed by the parties. Upon completion of work, the premises shall be left in good repair and an orderly, neat, clean and unobstructed condition.

Preparation: Awarded vendor shall not begin a project for which TIPS Member has not prepared the site, unless awarded vendor does the preparation work at no cost, or until TIPS Member includes the cost of site preparation in a purchase order.

Site preparation includes, but is not limited to: moving furniture, installing wiring for networks or power, and similar pre-installation requirements.

Registered sex offender restrictions: For work to be performed at schools, awarded vendor agrees that no employee of a sub-contractor who has been adjudicated to be a registered sex offender will perform work at any time when students are, or reasonably expected to be, present unless otherwise agreed by the TIPS Member. Awarded vendor agrees that a violation of this condition shall be considered a material breach and may result in the cancellation of the purchase order at the TIPS Member's discretion.

Awarded vendor must identify any additional costs associated with compliance of this term. If no costs are specified, compliance with this term will be provided at no additional charge. **Safety measures:** Awarded vendor shall take all reasonable precautions for the safety of employees on the worksite, and shall erect and properly maintain all necessary safeguards for protection of workers and the public. Awarded vendor shall post warning signs against all hazards created by the operation and work in progress. Proper precautions shall be taken pursuant to state law and standard practices to protect workers, general public and existing structures from injury or damage.

Smoking

Persons working under Agreement shall adhere to the TIPS Member's or local smoking statutes, codes or policies.

Marketing

Awarded vendor agrees to allow TIPS to use their name and logo within TIPS website, marketing materials and advertisement subject to any reasonable restrictions provided to TIPS in the Proposal to the Solicitation. The Vendor may submit an acceptable use directive for Vendor's names and logos with which TIPS agrees to comply. Any use of TIPS name and logo or any form of publicity, inclusive of press release, regarding this Agreement by awarded vendor must have prior approval from TIPS which will not be unreasonably withheld. Request may be made by email to TIPS@TIPS-USA.COM

Supplemental Agreements

The TIPS Member entity participating in the TIPS Agreement and awarded vendor may enter into a separate Supplemental Agreement or contract to further define the level of service requirements over and above the minimum defined in this Agreement such as but not limited to, invoice requirements, ordering requirements, specialized delivery, etc. Any Supplemental Agreement or contract developed as a result of this Agreement is exclusively between the TIPS Member entity customer and the Vendor. TIPS, its agents, TIPS Members and employees not a party to the Supplemental Agreement with the TIPS Member customer, shall not be made party to any claim for breach of such agreement unless named and agreed by the Party in question in writing in

the agreement. If a Vendor submitting a Proposal requires TIPS and/or TIPS Member to sign an additional agreement, those agreements shall comply with the award made by TIPS to the Vendor. Supplemental Vendor's Agreement documents may not become part of TIPS's Agreement with vendor unless and until an authorized representative of TIPS reviews and approves it. TIPS review and approval may be at any time during the life of this Vendor Agreement. TIPS permits TIPS Members to negotiate additional terms and conditions with the Vendor for the provision of goods or services under the Vendor's TIPS Agreement so long as they do not materially conflict with this Agreement.

Survival Clause

All applicable sales, leases, Supplemental Agreements, contracts, software license agreements, warranties or service agreements that were entered into between Vendor and TIPS or the TIPS Member Customer under the terms and conditions of this Agreement shall survive the expiration or termination of this Agreement. All Orders, Purchase Orders issued or contracts executed by TIPS or a TIPS Member and accepted by the Vendor prior to the expiration or termination of this agreement, shall survive expiration or termination of the Agreement, subject to previously agreed terms and conditions agreed by the parties or as otherwise specified herein relating to termination of this agreement.

Legal obligations

It is the responding Vendor's responsibility to be aware of and comply with all local, state and federal laws governing the sale of products/services identified in the applicable Solicitation that resulted in this Vendor Agreement and any awarded Agreement thereof. Applicable laws and regulations must be followed even if not specifically identified herein.

Audit rights

Due to transparency statutes and public accountability requirements of TIPS and TIPS Members', the awarded Vendor shall, at their sole expense, maintain appropriate due diligence of all purchases made by TIPS Member that utilizes this Agreement. TIPS and Region 8 ESC each reserve the right to audit the accounting of TIPS related purchases for a period of three (3) years from the time such purchases are made. This audit right shall survive termination of this Agreement for a period of one (1) year from the effective date of termination. In order to ensure and confirm compliance with this agreement, TIPS shall have authority to conduct audits of Awarded Vendor's pricing or TIPS transaction documentation with TIPS Members with 30 days' notice unless the audit is ordered by a Court Order or by a Government Agency with authority to do so without notice. Notwithstanding the foregoing, in the event that TIPS is made aware of any pricing being offered to eligible entities that is materially inconsistent with the pricing under this agreement, TIPS shall have the ability to conduct the audit internally or may engage a third- party auditing firm to investigate any possible non-compliant conduct or may terminate the Agreement according to the terms of this Agreement. In the event of an audit, the requested materials shall be reasonably provided in the time, format and at the location acceptable to Region 8 ESC or TIPS. TIPS agrees not to perform a random audit the TIPS transaction documentation more than once per calendar year, but reserves the right to audit for just cause or as required by any governmental agency or court with regulatory authority over TIPS or the TIPS Member.

Force Majeure

If by reason of Force Majeure, either party hereto shall be rendered unable wholly or in part to carry out its obligations under this Agreement then such party shall give notice and full particulars of Force Majeure in writing to the other party within a reasonable time after occurrence of the event or cause relied upon, and the obligation of the party giving such notice, so far as it is affected by such Force Majeure, shall be suspended during the continuance of the inability then claimed, except as hereinafter provided, but for no longer period, and such party shall endeavor to remove or overcome such inability with all reasonable dispatch.

Choice of Law

The Agreement between the Vendor and TIPS/ESC Region 8 and any addenda or other additions resulting from this procurement process, however described, shall be governed by, construed and enforced in accordance with the laws of the State of Texas, regardless of any conflict of laws principles.

Venue, Jurisdiction and Service of Process

Any Proceeding arising out of or relating to this procurement process or any contract issued by TIPS resulting from or any contemplated transaction shall be brought in a court of competent jurisdiction in Camp County, Texas and each of the parties irrevocably submits to the exclusive jurisdiction of said court in any such proceeding, waives any objection it may now or hereafter have to venue or to convenience of forum, agrees that all claims in respect of the Proceeding shall be heard and determined only in any such court, and agrees not to bring any proceeding arising out of or relating to this procurement process or any contract resulting from or any contemplated transaction in any other court. The parties agree that either or both of them may file a copy of this paragraph with any court as written evidence of the knowing, voluntary and freely bargained for agreement between the parties irrevocably to waive any objections to venue or to convenience of forum. Process in any Proceeding referred to in the first sentence of this Section may be served on any party anywhere in the world.

Venue for any dispute resolution process, other than litigation, between TIPS and the Vendor shall be located in Camp or Titus County, Texas.

Project Delivery Order Procedures

The TIPS Member having approved and signed an interlocal agreement, or other TIPS Membership document, may make a request of the awarded vendor under this Agreement when the TIPS Member desires goods or services awarded to the Vendor. Notification may occur via phone, the web, courier, email, fax, or in person. Upon notification of a pending request, the awarded vendor shall acknowledge the TIPS Member's request as soon as possible, but must make contact with the TIPS Member within two working days.

Status of TIPS Members as Related to This Agreement

TIPS Members stand in the place of TIPS as related to this agreement and have the same access to the proposal information and all related documents. TIPS Members have all the same rights under the awarded Agreement as TIPS.

Vendor's Resellers as Related to This Agreement

Vendor's Named Resellers under this Agreement shall comply with all terms and conditions of this agreement and all addenda or incorporated documents. All actions related to sales by Authorized Vendor's Resellers under this Agreement are the responsibility of the Awarded Vendor. If Resellers fail to report sales to TIPS under your Agreement, the awarded Vendor is responsible for their contractual failures and shall be billed for the fees. The awarded vendor may then recover the fees from their named reseller.

Support Requirements

If there is a dispute between the awarded vendor and TIPS Member, TIPS or its representatives will assist in conflict resolution or third party if requested by either party. TIPS, or its representatives, reserves the right to inspect any project and audit the awarded Vendor's TIPS project files, documentation and correspondence related to the requesting TIPS Member's order. If there are confidentiality requirements by either party, TIPS shall comply to the extent permitted by law.

Incorporation of Solicitation

The TIPS Solicitation which resulted in this Vendor Agreement, whether a Request for Proposals, the

Request for Competitive Sealed Proposals or Request for Qualifications solicitation, or other, the Vendor's response to same and all associated documents and forms made part of the solicitation process, including any addenda, are hereby incorporated by reference into this Agreement as if copied verbatim.

SECTION HEADERS OR TITLES

THE SECTION HEADERS OR TITLES WITHIN THIS DOCUMENT ARE MERELY GUIDES FOR CONVENIENCE AND ARE NOT FOR CLASSIFICATION OR LIMITING OF THE RESPONSIBILITIES OF THE PARTIES TO THIS DOCUMENT.

STATUTORY REQUIREMENTS

Texas governmental entities are prohibited from doing business with companies that fail to certify to this condition as required by Texas Government Code Sec. 2270.

By executing this agreement, you certify that you are authorized to bind the undersigned Vendor and that your company (1) does not boycott Israel; and (2) will not boycott Israel during the term of the Agreement.

You certify that your company is not listed on and does not and will not do business with companies that are on the Texas Comptroller of Public Accounts list of Designated Foreign Terrorists Organizations per Texas Gov't Code 2270.0153 found at <https://comptroller.texas.gov/purchasing/docs/foreign-terrorist.pdf>

You certify that if the certified statements above become untrue at any time during the life of this Agreement that the Vendor will notify TIPS within three (3) business day of the change by a letter on Vendor's letterhead from and signed by an authorized representative of the Vendor stating the non-compliance decision and the TIPS Agreement number and description at:

Attention: General Counsel
ESC Region 8/The Interlocal Purchasing System (TIPS)
4845 Highway 271 North
Pittsburg, TX,75686
And by an email sent to bids@tips-usa.com

Insurance Requirements

The undersigned Vendor agrees to maintain the below minimum insurance requirements for TIPS Contract Holders.

General Liability	\$1,000,000 each Occurrence/ Aggregate Automobile
Liability	\$300,000 Includes owned, hired & non-owned
Workers' Compensation	Statutory limits for the jurisdiction in which the Vendor performs under this Agreement.
Umbrella Liability	\$1,000,000

When the contractor or its subcontractors are liable for any damages or claims, the contractors' policy, when the Vendor is responsible for the claim, must be primary over any other valid and collectible insurance carried by the District. Any immunity available to TIPS or TIPS Members shall not be used as a defense by the contractor's insurance policy. The coverages and limits are to be considered minimum requirements and in no way limit the liability of the Contractor(s). Insurance shall be written by a carrier with an A-; VII or better rating in accordance with current A.M. Best Key Rating Guide. Only deductibles applicable to property damage are acceptable, unless proof of retention funds to cover said deductibles is provided. "Claims made" policies will not be accepted. Vendor's required minimum coverage shall not be suspended, voided, cancelled, non-renewed or

reduced in coverage or in limits unless replaced by a policy that provides the minimum required coverage except after thirty (30) days prior written notice by certified mail, return receipt requested has been given to TIPS or the TIPS Member if a project or pending delivery of an order is ongoing. Upon request, certified copies of all insurance policies shall be furnished to the TIPS or the TIPS Member.

Special Terms and Conditions

- **Orders:** All vendor orders received from TIPS Members must be emailed to TIPS at tipspo@tips-usa.com. Should a TIPS Member send an order directly to the Vendor, it is the Vendor's responsibility to forward a copy of the order to TIPS at the email above within 3 business days and confirm its receipt with TIPS.
- **Vendor Encouraging Members to bypass TIPS agreement:** Encouraging TIPS Members to purchase directly from the Vendor or through another agreement, when the Member has requested using the TIPS cooperative Agreement or price, and thereby bypassing the TIPS Agreement is a violation of the terms and conditions of this Agreement and will result in removal of the Vendor from the TIPS Program.
- **Order Confirmation:** All TIPS Member Agreement orders are approved daily by TIPS and sent to vendor. The Vendor should confirm receipt of orders to the TIPS Member (customer) within 3 business days.
- **Vendor custom website for TIPS:** If Vendor is hosting a custom TIPS website, updated pricing when effective. TIPS shall be notified when prices change in accordance with the award.
- **Back Ordered Products:** If product is not expected to ship within the time provided to the TIPS member by the Vendor, customer is to be notified within 3 business days and appropriate action taken based on customer request.

The TIPS Vendor Agreement Signature Page is inserted here.

TIPS Vendor Agreement Signature Form

RFP 191001 Heavy Duty Equipment

Company Name CLS Sewer Equipment Co. Inc.

Address 726 S. Sherman St.

City Richardson State TX Zip 75081

Phone 972-479-1335 Fax 972-479-1336

Email of Authorized Representative jerry@sewerfads.com

Name of Authorized Representative Jerry Somier

Title President

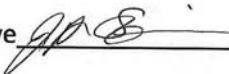
Signature of Authorized Representative 

Date 12-20-19

TIPS Authorized Representative Name Meredith Barton

Title Chief Operating Officer

TIPS Authorized Representative Signature 

Approved by ESC Region 8 

Date 1-23-2020



191001

**CLS Sewer Equipment Co. Inc.
Supplier Response**

Event Information

Number: 191001
Title: Heavy Duty Equipment
Type: Request for Proposal
Issue Date: 10/3/2019
Deadline: 12/20/2019 03:00 PM (CT)

Contact Information

Contact: Kristie Collins
Address: Region 8 Education Service Center
4845 US Highway 271 North
Pittsburg, TX 75686
Phone: +1 (866) 839-8477
Fax: +1 (866) 839-8472
Email: bids@tips-usa.com

CLS Sewer Equipment Co. Inc. Information

Contact: Jerry Sonnier
Address: 726 S Sherman St.
Richardson, TX 75081
Phone: (972) 479-1335
Email: jerry@SewerTools.com

By submitting your response, you certify that you are authorized to represent and bind your company.

Jerry Sonnier II

Signature

Submitted at 12/20/2019 1:46:46 PM

jerry@sewertools.com

Email

Requested Attachments

Vendor Agreement

CLSVendorAgreement.pdf

The vendor must download the Vendor Agreement from the attachment tab, fill in the requested information and upload the completed agreement.

DO NOT UPLOAD encrypted or password protected files.

Agreement Signature Form

CLSRavoTIPS.pdf

If you have not taken exception or deviation to the agreement language in the solicitation attributes, download the AGREEMENT SIGNATURE FORM from the "ATTACHMENTS" tab. This PDF document is a fillable form. Download the document to your computer, fill in the requested company information, print the file, SIGN the form, SCAN the completed and signed AGREEMENT SIGNATURE FORM, and upload here.

If you have taken exception to any of the agreement language and noted the exception in the deviations section of the attributes for the agreement, complete the AGREEMENT SIGNATURE FORM, but DO NOT SIGN until those deviations have been negotiated and resolved with TIPS management. Upload the unsigned form here, because this is a required document.

Pricing Spreadsheet #1

Pricing Ravo Systems CLS Equipment.pdf

The vendor must download the PRICING SPREADSHEET SHEET from the attachment tab, fill in the requested information and upload the completed spreadsheet.

DO NOT UPLOAD encrypted or password protected files.

Pricing Spreadsheet #2

Pricing Ravo Systems CLS Equipment.pdf

The vendor must download the PRICING SPREADSHEET SHEET from the attachment tab, fill in the requested information and upload the completed spreadsheet.

DO NOT UPLOAD encrypted or password protected files.

References

Copy of Copy of Reference_FormTIPS.pdf

The vendor must download the References spreadsheet from the attachment tab, fill in the requested information and upload the completed spreadsheet. DO NOT UPLOAD encrypted or password protected files.

Proposed Goods and Services

Please see additional attachments for our brochures and catalogs.docx

Please upload one or more documents or sheets describing your offerings, line cards, catalogs, links to offerings OR list links to your offerings that illustrate the catalog of proposed lines of goods and or services you carry and offer under this proposal. It does not have to be exhaustive but should, at a minimum tell us what you are offering. It could be as simple as a sheet with your link to your online catalog of goods and services.

Resellers/Dealers - COMPLETE AND UPLOAD ONLY IF YOU HAVE RESELLER OF YOUR GOODS OR SERVICES PROPOSED *No response*

If the PROPOSING vendor has resellers that will be selling for the vendor UNDER this contract, the vendor must download the Resellers/Dealers spreadsheet from the attachment tab, fill in the requested information and upload the completed spreadsheet.

DO NOT UPLOAD encrypted or password protected files.

HUB Subcontracting Plan Form OPTIONAL

No response

Completion of the HUB Subcontracting Plan Form is OPTIONAL. THE FORM INFORMATION HAS NO EFFECT ON YOUR EVALUATION SCORE. IT IS INFORMATIONAL ONLY. Some Texas State agencies and Universities require it be a part of the file when determining if they can use a TIPS contract. If you choose to complete one, it is not project specific but the general plan the vendor would use. Complete it as best you can.

Vendor can download the HUB Subcontracting Plan Form from the "Attachments" tab and upload their HUB Subcontracting Plan Form.

D/M/WBE Certification OPTIONAL

No response

D/M/WBE Certification documentation may be scanned and uploaded if you desire to claim your status as one of the identified enterprises. (Disadvantaged Business Enterprise, Minority Business Enterprise and/or Woman Business Enterprise) If vendor has more than one certification scan into one document. (PDF Format ONLY)

DO NOT UPLOAD encrypted or password protected files.

HUB Certification OPTIONAL

No response

HUB Certification documentation may be scanned and uploaded if you desire to document you status as a HUB company. (Historically Underutilized Business) (PDF Format ONLY)

DO NOT UPLOAD encrypted or password protected files.

Warranty

No response

Warranty information (if applicable) must be scanned and uploaded. (PDF Format ONLY)

DO NOT UPLOAD encrypted or password protected files.

Supplementary

No response

Supplementary information may be scanned and uploaded. (Company information, brochures, catalogs, etc.) (PDF Format ONLY)

DO NOT UPLOAD encrypted or password protected files.

All Other Certificates

No response

All Other Certificates (if applicable) must be scanned and uploaded. If vendor has more than one other certification scan into one document. (PDF Format ONLY)

DO NOT UPLOAD encrypted or password protected files.

Logo and Other Company Marks

logowordtoolsnewbule (2).png

If you desire, please upload your company logo to be added to your individual profile page on the TIPS website. If any particular specifications are required for use of your company logo, please upload that information under the Supplementary section or another non-required section under the "Response Attachment" tab. Preferred Logo Format: 300 x 25 px - .png, .eps, .jpeg preferred

Conflict of Interest Form CIQ- ONLY REQUIRED IF A CONFLICT EXISTS PER THE INSTRUCTIONS

No response

ONLY REQUIRED IF A CONFLICT EXISTS PER THE INSTRUCTIONS

Conflict of Interest Form for Vendors that are required to submit the form. The Conflict of Interest Form is included in the Base documents or can be found at <https://www.tips-usa.com/assets/documents/docs/CIQ.pdf>.

Certificate of Corporate Offerer - COMPLETE ONLY IF OFFERER IS A CORPORATION CLSRavoTIPS.pdf

COMPLETE AND UPLOAD FORM IN ATTACHMENTS SECTION ONLY IF OFFERER IS A CORPORATION

Disclosure of Lobbying Activities Standard Form LLL

No response

ONLY IF you answered "I HAVE Lobbied per above" to attribute #66, please download and complete and upload the Standard Form-LLL, "disclosure Form to Report Lobbying," in the Response attachments section.

REQUIRED CONFIDENTIALITY FORM. Complete the form according to your company requirements, make any desired attachments and upload to the appropriate section under "Response Attachments" THIS FORM DETERMINES HOW ESC8/TIPS RESPONDS TO LEGAL PUBLIC INFORMATION REQUESTS.

Response Attachments

New RAVO 5 iSeries US brochure.pdf

Ravo I5 Catalog

Brochure Mathieu MC 210 Sweeper.pdf

Mathieu MC210 Catalog

MC 110 Commercial Brochure GB.pdf

MC 110 Catalog

Bid Attributes

1	<p>Yes - No</p> <p>Disadvantaged/Minority/Women Business Enterprise - D/M/WBE (Required by some participating governmental entities) Vendor certifies that their firm is a D/M/WBE? Vendor must upload proof of certification to the "Response Attachments" D/M/WBE CERTIFICATES section.</p> <p><input type="text" value="NO"/></p>
----------	---

2	<p>Yes - No</p> <p>Historically Underutilized Business - HUB (Required by some participating governmental entities) Vendor certifies that their firm is a HUB as defined by the State of Texas at https://comptroller.texas.gov/purchasing/vendor/hub/ or in a HUBZone as defined by the US Small Business Administration at https://www.sba.gov/offices/headquarters/ohp</p> <p>Proof of one or both may be submitted. Vendor must upload proof of certification to the "Response Attachments" HUB CERTIFICATES section.</p> <p><input type="text" value="No"/></p>
----------	---

3	<p>Yes - No</p> <p>The Vendor can provide services and/or products to all 50 US States?</p> <p><input type="text" value="No"/></p>
----------	---

4	<p>States Served:</p> <p>If answer is NO to question #3, please list which states can be served. (Example: AR, OK, TX)</p> <p><input type="text" value="State of Texas"/></p>
----------	--

5	<p>Company and/or Product Description:</p> <p>This information will appear on the TIPS website in the company profile section, if awarded a TIPS contract. (Limit 750 characters.)</p> <p><input type="text" value="CLS Sewer Equipment Co Inc, We proudly offer the best equipment, sales, rentals, parts and service in the water and sewer industry."/></p>
----------	---

6	Primary Contact Name Primary Contact Name Jerry Sonnier II
7	Primary Contact Title Primary Contact Title President
8	Primary Contact Email Primary Contact Email jerry@sewertools.com
9	Primary Contact Phone Enter 10 digit phone number. (No dashes or extensions) Example: 8668398477 972-479-1335
10	Primary Contact Fax Enter 10 digit phone number. (No dashes or extensions) Example: 8668398477 No response
11	Primary Contact Mobile Enter 10 digit phone number. (No dashes or extensions) Example: 8668398477 214-878-7380
12	Secondary Contact Name Secondary Contact Name Jennifer Sonnier
13	Secondary Contact Title Secondary Contact Title Accounts
14	Secondary Contact Email Secondary Contact Email jennifer@sewertools.com
15	Secondary Contact Phone Enter 10 digit phone number. (No dashes or extensions) Example: 8668398477 972-479-1335
16	Secondary Contact Fax Enter 10 digit phone number. (No dashes or extensions) Example: 8668398477 No response

17	Secondary Contact Mobile Enter 10 digit phone number. (No dashes or extensions) Example: 8668398477 <input type="text" value="No response"/>
-----------	--

18	Admin Fee Contact Name Admin Fee Contact Name. This person is responsible for paying the admin fee to TIPS. <input type="text" value="Jennifer Sonnier"/>
-----------	--

19	Admin Fee Contact Email Admin Fee Contact Email <input type="text" value="accounts@sewertools.com"/>
-----------	---

20	Admin Fee Contact Phone Enter 10 digit phone number. (No dashes or extensions) Example: 8668398477 <input type="text" value="972-479-1335"/>
-----------	--

21	Purchase Order Contact Name Purchase Order Contact Name. This person is responsible for receiving Purchase Orders from TIPS. <input type="text" value="Jerry Sonnier II"/>
-----------	---

22	Purchase Order Contact Email Purchase Order Contact Email <input type="text" value="Jerry@Sewertools.com"/>
-----------	--

23	Purchase Order Contact Phone Enter 10 digit phone number. (No dashes or extensions) Example: 8668398477 <input type="text" value="972-479-1335"/>
-----------	---

24	Company Website Company Website (Format - www.company.com) <input type="text" value="www.SewerTools.com"/>
-----------	---

25	Federal ID Number: Federal ID Number also known as the Employer Identification Number. (Format - 12-3456789) <input type="text" value=""/>
-----------	---

26	Primary Address Primary Address <input type="text" value="726 S. Sherman St."/>
-----------	--

27	Primary Address City Primary Address City <input type="text" value="Richardson"/>
-----------	--

28	Primary Address State
	Primary Address State (2 Digit Abbreviation)
<input type="text" value="TX"/>	

29	Primary Address Zip
	Primary Address Zip
<input type="text" value="75081"/>	

30	Search Words:
	Please list search words to be posted in the TIPS database about your company that TIPS website users might search. Words may be product names, manufacturers, or other words associated with the category of award. YOU MAY NOT LIST NON-CATEGORY ITEMS. (Limit 500 words) (Format: product, paper, construction, manufacturer name, etc.)
<input type="text" value="Heavy Equipment
Water Sewer
Vacuum
Jetter
Nozzles
Hydro excavation
Hose
Pump"/>	

31	Do you want TIPS Members to be able to spend Federal grant funds with you if awarded? Is it your intent to be able to sell to our members regardless of the fund source, whether it be local, state or federal?
	Most of our members receive Federal Government grants and they make up a significant portion of their budgets. The members need to know if your company is willing to sell to them when they spend federal budget funds on their purchase. There are attributes that follow that are provisions from the federal regulations in 2 CFR part 200. Your answers will determine if your award will be designated as Federal or Education Department General Administrative Regulations (EDGAR)compliant. Do you want TIPS Members to be able to spend Federal grant funds with you if awarded and is it your intent to be able to sell to our members regardless of the fund source, whether it be local, state or federal?
<input type="text" value="Yes"/>	

32	Yes - No
	Certification of Residency (Required by the State of Texas) The vendor's ultimate parent company or majority owner :
(A) has its principal place of business in Texas;	
OR	
(B) employs at least 500 persons in Texas?	
<input type="text" value="Yes"/>	

33	Company Residence (City) Vendor's principal place of business is in the city of? <input type="text" value="Richardson"/>
-----------	---

34	Company Residence (State) Vendor's principal place of business is in the state of? <input type="text" value="Texas"/>
-----------	--

35	Discount Offered - CAUTION READ CAREFULLY BECAUSE VENDORS FREQUENTLY MAKE MISTAKES ON THIS ATTRIBUTE QUESTION Remember this is a MINIMUM discount percentage so, be sure the discount percentage inserted here can be applied to ANY OFFERING OF GOODS OR SERVICES THROUGH OUT THE LIFE OF THE CONTRACT CAUTION: BE CERTAIN YOU CAN HONOR THIS MINIMUM DISCOUNT PERCENTAGE ON ANY OFFERED SERVICE OR GOOD. What is the MINIMUM percentage discount off of any item or service you offer to TIPS Members that is in your regular catalog (as defined in the RFP document), website, store or shelf pricing? The resulting price of any goods or services Catalog list prices after this discount is applied is a ceiling on your pricing and not a floor because, in order to be more competitive in the individual circumstance, you may offer a larger discount depending on the items or services purchased and the quantity at time of sale. Must answer with a number between 0% and 100%. <input type="text" value="1%"/>
-----------	---

36	TIPS administration fee By submitting a proposal, I agree that all pricing submitted to TIPS shall include the participation fee, as designated in the solicitation or as otherwise agreed in writing and shall be remitted to TIPS by the Vendor as agreed in the Vendor agreement. I agree that the fee shall not and will not be added by the vendor as a separate line item on a TIPS member invoice, quote, proposal or any other written communications with the TIPS member.
-----------	---

37	Yes - No Vendor agrees to remit to TIPS the required administration fee? TIPS/ESC Region 8 is required by Texas Government Code § 791 to be compensated for its work and thus, failure to agree shall render your response void and it will not be considered. <input type="text" value="Yes"/>
-----------	---

38	Yes - No Do you offer additional discounts to TIPS members for large order quantities or large scope of work? <input type="text" value="No"/>
-----------	--

39	Years Experience Company years experience in this category? This is an evaluation criterion worth a maximum of 10 points. See RFP for more information. <input type="text" value="35"/>
-----------	--

40 Resellers:

Does the vendor have resellers that it will name under this contract? Resellers are defined as other companies that sell your products under an agreement with you, the awarded vendor of TIPS.

EXAMPLE: BIGmart is a reseller of ACME brand televisions. If ACME were a TIPS awarded vendor, then ACME would list BIGmart as a reseller.

(If applicable, vendor should download the Reseller/Dealers spreadsheet from the Attachments section, fill out the form and submit the document in the "Response Attachments" RESELLERS section.

41 Pricing discount percentage are guaranteed for?

Does the vendor agrees to honor the proposed pricing discount percentage off regular catalog (as defined in the RFP document), website, store or shelf pricing for the term of the award?

42 Right of Refusal

Does the proposing vendor wish to reserve the right not to perform under the awarded agreement with a TIPS member at vendor's discretion?

43 NON-COLLUSIVE BIDDING CERTIFICATE

By submission of this bid or proposal, the Bidder certifies that:

- 1) This bid or proposal has been independently arrived at without collusion with any other Bidder or with any Competitor;
- 2) This bid or proposal has not been knowingly disclosed and will not be knowingly disclosed, prior to the opening of bids, or proposals for this project, to any other Bidder, Competitor or potential competitor;
- 3) No attempt has been or will be made to induce any other person, partnership or corporation to submit or not to submit a bid or proposal;
- 4) The person signing this bid or proposal certifies that he has fully informed himself regarding the accuracy of the statements contained in this certification, and under the penalties being applicable to the Bidder as well as to the person signing in its behalf.

Not a negotiable term. Failure to agree will render your proposal non-responsive and it will not be considered.

4 4 CONFLICT OF INTEREST QUESTIONNAIRE - FORM CIQ - Do you have any CONFLICT OF INTEREST TO REPORT OR DISCLOSE under this statutory requirement?

Do you have any CONFLICT OF INTEREST TO REPORT OR DISCLOSE under this statutory requirement? YES or NO

If you have a conflict of interest as described in this form or the Local Government Code Chapter 176, cited therein- you are required to complete and file with TIPS.

You may find the Blank CIQ form on our website at:

Copy and Paste the following link into a new browser or tab:

<https://www.tips-usa.com/assets/documents/docs/CIQ.pdf>

There is an optional upload for this form provided if you have a conflict and must file the form.

4 5 Filing of Form CIQ

If yes (above), have you filed a form CIQ by uploading the form to this RFP as directed above?

4 6 Regulatory Standing

I certify to TIPS for the proposal attached that my company is in good standing with all governmental agencies Federal or state that regulate any part of our business operations. If not, please explain in the next attribute question.

4 7 Regulatory Standing

Regulatory Standing explanation of no answer on previous question.

4 8 Antitrust Certification Statements (Tex. Government Code § 2155.005)

By submission of this bid or proposal, the Bidder certifies that:

I affirm under penalty of perjury of the laws of the State of Texas that:

(1) I am duly authorized to execute this contract on my own behalf or on behalf of the company, corporation, firm, partnership or individual (Company) listed below;

(2) In connection with this bid, neither I nor any representative of the Company has violated any provision of the Texas Free Enterprise and Antitrust Act, Tex. Bus. & Comm. Code Chapter 15;

(3) In connection with this bid, neither I nor any representative of the Company has violated any federal antitrust law ;

(4) Neither I nor any representative of the Company has directly or indirectly communicated any of the contents of this bid to a competitor of the Company or any other company, corporation, firm, partnership or individual engaged in the same line of business as the Company.

Suspension or Debarment Instructions

Instructions for Certification:

1. By answering yes to the next Attribute question below, the vendor and prospective lower tier participant is providing the certification set out herein in accordance with these instructions.
2. The certification in this clause is a material representation of fact upon which reliance was placed when this transaction was entered into. If it is later determined that the prospective lower tier participant knowingly rendered an erroneous certification in addition to other remedies available to the federal government, the department or agency with which this transaction originated may pursue available remedies, including suspension and / or debarment.
3. The prospective lower tier participant shall provide immediate written notice to the person to which this proposal is submitted if at any time the prospective lower tier participant learns that its certification was erroneous when submitted or has become erroneous by reason of changed circumstances.
4. The terms "covered transaction," "debarred," "suspended," "ineligible," "lower tier covered transaction," "participants," "person," "primary covered transaction," "principal," "proposal" and "voluntarily excluded," as used in this clause, have the meanings set out in the Definitions and Coverage sections of rules implementing Executive Order 12549.
9. You may contact the person to which this proposal is submitted for assistance in obtaining a copy of those regulations.
5. The prospective lower tier participant agrees by submitting this form that, should the proposed covered transaction be entered into, it shall not knowingly enter into any lower tier covered transaction with a person who is debarred, suspended, declared ineligible or voluntarily excluded from participation in this covered transaction, unless authorized by the department or agency with which this transaction originated.
6. The prospective lower tier participant further agrees by submitting this form that it will include this clause titled "Certification Regarding Debarment, Suspension, Ineligibility and Voluntary Exclusion-Lower Tier Covered Transaction" without modification in all lower tier covered transactions and in all solicitations for lower tier covered transactions.
7. A participant in a covered transaction may rely upon a certification of a prospective participant in a lower tier covered transaction that it is not debarred, suspended, ineligible or voluntarily excluded from the covered transaction, unless it knows that the certification is erroneous. A participant may decide the method and frequency by which it determines the eligibility of its principals. Each participant may, but is not required to, check the Nonprocurement List.
8. Nothing contained in the foregoing shall be construed to require establishment of a system of records in order to render in good faith the certification required by this clause. The knowledge and information of a participant is not required to exceed that which is normally possessed by a prudent person in the ordinary course of business dealings.
9. Except for transactions authorized under paragraph 5 of these instructions, if a participant in a covered transaction knowingly enters into a lower tier covered transaction with a person who is suspended, debarred, ineligible or voluntarily excluded from participation in this transaction, in addition to other remedies available to the federal government, the department or agency with which this transaction originated may pursue available remedies, including suspension and / or debarment.

50

Suspension or Debarment Certification

By answering yes, you certify that no federal suspension or debarment is in place, which would preclude receiving a federally funded contract as described above.

Debarment and Suspension (Executive Orders 12549 and 12689)—A contract award (see 2 CFR 180.220) must not be made to parties listed on the government-wide exclusions in the System for Award Management (SAM), in accordance with the OMB guidelines at 2 CFR 180 that implement Executive Orders 12549 (3 CFR part 1986 Comp., p. 189) and 12689 (3 CFR part 1989 Comp., p. 235), “Debarment and Suspension.” SAM Exclusions contains the names of parties debarred, suspended, or otherwise excluded by agencies, as well as parties declared ineligible under statutory or regulatory authority other than Executive Order 12549.

By answering yes, you certify that no federal suspension or debarment is in place, which would preclude receiving a federally funded contract as described above.

51

Non-Discrimination Statement and Certification

In accordance with Federal civil rights law, all U.S. Departments, including the U.S. Department of Agriculture (USDA) civil rights regulations and policies, the USDA, its Agencies, offices, and employees, and institutions participating in or administering USDA programs are prohibited from discriminating based on race, color, national origin, religion, sex, gender identity (including gender expression), sexual orientation, disability, age, marital status, family/parental status, income derived from a public assistance program, political beliefs, or reprisal or retaliation for prior civil rights activity, in any program or activity conducted or funded by USDA (not all bases apply to all programs). Remedies and complaint filing deadlines vary by program or incident.

Persons with disabilities who require alternative means of communication for program information (e.g., Braille, large print, audiotape, American Sign Language, etc.) should contact the responsible Agency or USDA's TARGET Center at (202) 720-2600 (voice and TTY) or contact USDA through the Federal Relay Service at (800) 877-8339. Additionally, program information may be made available in languages other than English.

To file a program discrimination complaint, complete the USDA Program Discrimination Complaint Form, AD-3027, found online at How to File a Program Discrimination Complaint and at any USDA office or write a letter addressed to USDA and provide in the letter all of the information requested in the form. To request a copy of the complaint form, call (866) 632-9992. Submit your completed form or letter to USDA by: (1) mail: U.S. Department of Agriculture, Office of the Assistant Secretary for Civil Rights, 1400 Independence Avenue, SW, Washington, D.C. 20250-9410; (2) fax: (202) 690-7442; or (3) email: program.intake@usda.gov.

(Title VI of the Education Amendments of 1972; Section 504 of the Rehabilitation Act of 1973; the Age Discrimination Act of 1975; Title 7 CFR Parts 15, 15a, and 15b; the Americans with Disabilities Act; and FNS Instruction 113-1, Civil Rights Compliance and Enforcement – Nutrition Programs and Activities)

All U.S. Departments, including the USDA are equal opportunity provider, employer, and lender.

Not a negotiable term. Failure to agree by answering YES will render your proposal non-responsive and it will not be considered. I certify that in the performance of a contract with TIPS or its members, that our company will conform to the foregoing anti-discrimination statement and comply with the cited and all other applicable laws and regulations.

5 2 2 CFR PART 200 Contract Provisions Explanation

Required Federal contract provisions of Federal Regulations for Contracts for contracts with ESC Region 8 and TIPS Members:

The following provisions are required to be in place and agreed if the procurement is funded in any part with federal funds.

The ESC Region 8 and TIPS Members are the subgrantee or Subrecipient by definition. Most of the provisions are located in 2 CFR PART 200 - Appendix II to Part 200—Contract Provisions for Non-Federal Entity Contracts Under Federal Awards at 2 CFR PART 200. Others are included within 2 CFR part 200 et al.

In addition to other provisions required by the Federal agency or non-Federal entity, all contracts made by the non-Federal entity under the Federal award must contain provisions covering the following, as applicable.

5 3 2 CFR PART 200 Contracts

Contracts for more than the simplified acquisition threshold currently set at \$150,000, which is the inflation adjusted amount determined by the Civilian Agency Acquisition Council and the Defense Acquisition Regulations Council (Councils) as authorized by 41 U.S.C. 1908, must address administrative, contractual, or legal remedies in instances where contractors violate or breach contract terms, and provide for such sanctions and penalties as appropriate.

Notice: Pursuant to the above, when federal funds are expended by ESC Region 8 and TIPS Members, ESC Region 8 and TIPS Members reserves all rights and privileges under the applicable laws and regulations with respect to this procurement in the event of breach of contract by either party.

Does vendor agree?

5 4 2 CFR PART 200 Termination

Termination for cause and for convenience by the grantee or subgrantee including the manner by which it will be effected and the basis for settlement. (All contracts in excess of \$10,000)

Pursuant to the above, when federal funds are expended by ESC Region 8 and TIPS Members, ESC Region 8 and TIPS Members reserves the right to terminate any agreement in excess of \$10,000 resulting from this procurement process for cause after giving the vendor an appropriate opportunity and up to 30 days, to cure the causal breach of terms and conditions. ESC Region 8 and TIPS Members reserves the right to terminate any agreement in excess of \$10,000 resulting from this procurement process for convenience with 30 days notice in writing to the awarded vendor. The vendor would be compensated for work performed and goods procured as of the termination date if for convenience of the ESC Region 8 and TIPS Members. Any award under this procurement process is not exclusive and the ESC Region 8 and TIPS reserves the right to purchase goods and services from other vendors when it is in the best interest of the ESC Region 8 and TIPS.

Does vendor agree?

5
5

2 CFR PART 200 Clean Air Act

Clean Air Act (42 U.S.C. 7401-7671q.) and the Federal Water Pollution Control Act (33 U.S.C. 1251-1387), as amended—Contracts and subgrants of amounts in excess of \$150,000 must contain a provision that requires the non-Federal award to agree to comply with all applicable standards, orders or regulations issued pursuant to the Clean Air Act (42 U.S.C. 7401-7671q) and the Federal Water Pollution Control Act as amended (33 U.S.C. 1251-1387). Violations must be reported to the Federal awarding agency and the Regional Office of the Environmental Protection Agency (EPA).

Pursuant to the Clean Air Act, et al above, when federal funds are expended by ESC Region 8 and TIPS Members, ESC Region 8 and TIPS Members requires that the proposer certify that during the term of an award by the ESC Region 8 and TIPS Members resulting from this procurement process the vendor agrees to comply with all of the above regulations, including all of the terms listed and referenced therein.

Does vendor agree?

5
6

2 CFR PART 200 Byrd Anti-Lobbying Amendment

Byrd Anti-Lobbying Amendment (31 U.S.C. 1352)—Contractors that apply or bid for an award exceeding \$100,000 must file the required certification. Each tier certifies to the tier above that it will not and has not used Federal appropriated funds to pay any person or organization for influencing or attempting to influence an officer or employee of any agency, a member of Congress, officer or employee of Congress, or an employee of a member of Congress in connection with obtaining any Federal contract, grant or any other award covered by 31 U.S.C. 1352. Each tier must also disclose any lobbying with non-Federal funds that takes place in connection with obtaining any Federal award. Such disclosures are forwarded from tier to tier up to the non-Federal award.

Pursuant to the above, when federal funds are expended by ESC Region 8 and TIPS Members, ESC Region 8 and TIPS Members requires the proposer certify that during the term and during the life of any contract with ESC Region 8 and TIPS Members resulting from this procurement process the vendor certifies to the terms included or referenced herein.

Does vendor agree?

5
7

2 CFR PART 200 Federal Rule

Compliance with all applicable standards, orders, or requirements issued under section 306 of the Clean Air Act (42 U.S.C. 1857(h)), section 508 of the Clean Water Act (33 U.S.C. 1368), Executive Order 11738, and Environmental Protection Agency regulations (40 CFR part 15). (Contracts, subcontracts, and subgrants of amounts in excess of \$100,000)

Pursuant to the above, when federal funds are expended by ESC Region 8 and TIPS Members, ESC Region 8 and TIPS Members requires the proposer certify that in performance of the contracts, subcontracts, and subgrants of amounts in excess of \$100,000, the vendor will be in compliance with all applicable standards, orders, or requirements issued under section 306 of the Clean Air Act (42 U.S.C. 1857(h)), section 508 of the Clean Water Act (33 U.S.C. 1368), Executive Order 11738, and Environmental Protection Agency regulations (40 CFR part 15).

Does vendor certify that it is in compliance with the Clean Air Act?

58 2 CFR PART 200 Procurement of Recovered Materials

A non-Federal entity that is a state agency or agency of a political subdivision of a state and its contractors must comply with section 6002 of the Solid Waste Disposal Act, as amended by the Resource Conservation and Recovery Act. The requirements of Section 6002 include procuring only items designated in guidelines of the Environmental Protection Agency (EPA) at 40 CFR part 247 that contain the highest percentage of recovered materials practicable, consistent with maintaining a satisfactory level of competition, where the purchase price of the item exceeds \$10,000 or the value of the quantity acquired during the preceding fiscal year exceeded \$10,000; procuring solid waste management services in a manner that maximizes energy and resource recovery; and establishing an affirmative procurement program for procurement of recovered materials identified in the EPA guidelines.

Does vendor certify that it is in compliance with the Solid Waste Disposal Act as described above?

59 Certification Regarding Lobbying

Applicable to Grants, Subgrants, Cooperative Agreements, and Contracts Exceeding \$100,000 in Federal Funds

Submission of this certification is a prerequisite for making or entering into this transaction and is imposed by section 1352, Title 31, U.S. Code. This certification is a material representation of fact upon which reliance was placed when this transaction was made or entered into. Any person who fails to file the required certification shall be subject to a civil penalty of not less than \$10,000 and not more than \$100,000 for each such failure.

The undersigned certifies, to the best of his or her knowledge and belief, that:

(1) No Federal appropriated funds have been paid or will be paid by or on behalf of the undersigned, to any person for influencing or attempting to influence an officer or employee of any agency, a Member of Congress, an officer or employee of congress, or an employee of a Member of Congress in connection with the awarding of a Federal contract, the making of a Federal grant, the making of a Federal loan, the entering into a cooperative agreement, and the extension, continuation, renewal, amendment, or modification of a Federal contract, grant, loan, or cooperative agreement.

(2) If any funds other than Federal appropriated funds have been paid or will be paid to any person for influencing or attempting to influence an officer or employee of any agency, a Member of Congress, an officer or employee of congress, or an employee of a Member of Congress in connection with this Federal grant or cooperative agreement, the undersigned shall complete and submit Standard Form-LLL, "disclosure Form to Report Lobbying," in accordance with its instructions.

(3) The undersigned shall require that the language of this certification be included in the award documents for all covered subawards exceeding \$100,000 in Federal funds at all appropriate tiers and that all subrecipients shall certify and disclose accordingly.

60 If you answered "I HAVE lobbied per above to the previous question.

IF you answered "I HAVE lobbied" per above Attribute question, you must download the Lobbying Report "Standard Form LLL, disclosure Form to Report Lobbying" which includes instruction on completing the form, complete and submit it in the Response Attachments section as a report of the lobbying activities you performed or paid others to perform.

**6
1** **Subcontracting with small and minority businesses, women's business enterprises, and labor surplus area firms.**

Do you ever anticipate the possibility of subcontracting any of your work under this award if you are successful?

IF NO, DO NOT ANSWER THE NEXT ATTRIBUTE QUESTION. . IF YES, and ONLY IF YES, you must answer the next question YES if you want a TIPS Member to be authorized to spend Federal Grant Funds for Procurement.

**6
2** **ONLY IF YES TO THE PREVIOUS QUESTION OR if you ever do subcontract any part of your performance under the TIPS Agreement, do you agree to comply with the following federal requirements?**

ONLY IF YES TO THE PREVIOUS QUESTION OR if you ever do subcontract any part of your performance under the TIPS Agreement,

do you agree to comply with the following federal requirements?

Federal Regulation 2 CFR §200.321 Contracting with small and minority businesses, women's business enterprises, and labor surplus area firms. (a)The non-Federal entity must take all necessary affirmative steps to assure that minority businesses, women's business enterprises, and labor surplus area firms are used when possible.

(b) Affirmative steps must include:(1) Placing qualified small and minority businesses and women's business enterprises on solicitation lists;

(2) Assuring that small and minority businesses, and women's business enterprises are solicited whenever they are potential sources;

(3) Dividing total requirements, when economically feasible, into smaller tasks or quantities to permit maximum participation by small and minority businesses, and women's business enterprises;

(4) Establishing delivery schedules, where the requirement permits, which encourage participation by small and minority businesses, and women's business enterprises;

(5) Using the services and assistance, as appropriate, of such organizations as the Small Business Administration and the Minority Business Development Agency of the Department of Commerce ; and

(6) Requiring the prime contractor, if subcontracts are to be let, to take the affirmative steps listed in paragraphs(1) through (5) of this section.

6 **Indemnification**

3

The ESC Region 8 and TIPS is a Texas Political Subdivision and a local governmental entity; therefore, is prohibited from indemnifying third parties pursuant to the Texas Constitution (Article 3, Section 52) except as specifically provided by law or as ordered by a court of competent jurisdiction. A provision in a contract to indemnify or hold a party harmless is a promise to pay for any expenses the indemnified party incurs, if a specified event occurs, such as breaching the terms of the contract or negligently performing duties under the contract. Article III, Section 49 of the Texas Constitution states that "no debt shall be created by or on behalf of the State ..." The Attorney General has counseled that a contractually imposed obligation of indemnity creates a "debt" in the constitutional sense. Tex. Att'y Gen. Op. No. MW-475 (1982). Contract clauses which require the System or institutions to indemnify must be deleted or qualified with "to the extent permitted by the Constitution and Laws of the State of Texas." Liquidated damages, attorney's fees, waiver of vendor's liability, and waiver of statutes of limitations clauses should also be deleted or qualified with "to the extent permitted by the Constitution and laws of State of Texas."

Not a negotiable term. Failure to agree will render your proposal non-responsive and it will not be considered. Do you agree to these terms?

6 **Remedies**

4

The parties shall be entitled to exercise any right or remedy available to it either at law or in equity, subject to the choice of law, venue and service of process clauses limitations agreed herein. Nothing in this agreement shall commit the TIPS to an arbitration resolution of any disagreement under any circumstances. Any Claim arising out of or related to the Contract, except for those specifically waived under the terms of the Contract, may, after denial of the Board of Directors, be subject to mediation at the request of either party. Any issues not resolved hereunder MAY be referred to non-binding mediation to be conducted by a mutually agreed upon mediator as a prerequisite to the filing of any lawsuit over such issue(s). The parties shall share the mediator's fee and any associated filing fee equally. Mediation shall be held in Camp or Titus County, Texas. Agreements reached in mediation shall be reduced to writing, and will be subject to the approval by the District's Board of Directors, signed by the Parties if approved by the Board of Directors, and, if signed, shall thereafter be enforceable as provided by the laws of the State of Texas.

Do you agree to these terms?

6 **Remedies Explanation of No Answer**

5

6
6 **Choice of Law**

The agreement between the Vendor and TIPS/ESC Region 8 and any addenda or other additions resulting from this procurement process, however described, shall be governed by, construed and enforced in accordance with the laws of the State of Texas, regardless of any conflict of laws principles.
THIS DOES NOT APPLY to a vendor's agreement entered into with a TIPS Member, as the Member may be located outside Texas.

Not a negotiable term. Failure to agree will render your proposal non-responsive and it will not be considered. Do you agree to these terms?

6
7 **Jurisdiction and Service of Process**

Any Proceeding arising out of or relating to this procurement process or any contract issued by TIPS resulting from or any contemplated transaction shall be brought in a court of competent jurisdiction in Camp County, Texas and each of the parties irrevocably submits to the exclusive jurisdiction of said court in any such proceeding, waives any objection it may now or hereafter have to venue or to convenience of forum, agrees that all claims in respect of the Proceeding shall be heard and determined only in any such court, and agrees not to bring any proceeding arising out of or relating to this procurement process or any contract resulting from or any contemplated transaction in any other court. The parties agree that either or both of them may file a copy of this paragraph with any court as written evidence of the knowing, voluntary and freely bargained for agreement between the parties irrevocably to waive any objections to venue or to convenience of forum. Process in any Proceeding referred to in the first sentence of this Section may be served on any party anywhere in the world. Venue clauses in contracts with TIPS members may be determined by the parties.

Not a negotiable term. Failure to agree will render your proposal non-responsive and it will not be considered. Do you agree to these terms?

6
8 **Infringement(s)**

The successful vendor will be expected to indemnify and hold harmless the TIPS and its employees, officers, agents, representatives, contractors, assignees and designees from any and all third party claims and judgments involving infringement of patent, copyright, trade secrets, trade or service marks, and any other intellectual or intangible property rights attributed to or claims based on the Vendor's proposal or Vendor's performance of contracts awarded and approved.

Do you agree to these terms?

6
9 **Infringement(s) Explanation of No Answer**

7
0 **Contract Governance**

Any contract made or entered into by the TIPS is subject to and is to be governed by Section 271.151 et seq, Tex Local Gov't Code. Otherwise, TIPS does not waive its governmental immunities from suit or liability except to the extent expressly waived by other applicable laws in clear and unambiguous language.

7
1

Payment Terms and Funding Out Clause

Payment Terms:

TIPS or TIPS members shall not be liable for interest or late payment fees on past due balances at a rate higher than permitted by the laws or regulations of the jurisdiction of the TIPS Member.

Funding Out Clause:

Vendor agrees to abide by the laws and regulations, including Texas Local Government Code § 271.903, or any statutory or regulatory limitations of the jurisdiction of any TIPS Member which governs contracts entered into by the Vendor and TIPS or a TIPS Member that requires all contracts approved by TIPS or a TIPS Member are subject to the budgeting and appropriation of currently available funds by the entity or its governing body.

See statute(s) for specifics or consult your legal counsel.

Not a negotiable term. Failure to agree will render your proposal non-responsive and it will not be considered.

Do you agree to these terms?

7
2

Insurance and Fingerprint Requirements Information

Insurance

If applicable and your staff will be on TIPS member premises for delivery, training or installation etc. and/or with an automobile, you must carry automobile insurance as required by law. You may be asked to provide proof of insurance.

Fingerprint

It is possible that a vendor may be subject to Chapter 22 of the Texas Education Code. The Texas Education Code, Chapter 22, Section 22.0834. Statutory language may be found at: <http://www.statutes.legis.state.tx.us/>

If the vendor has staff that meet both of these criterion:

- (1) will have continuing duties related to the contracted services; and
- (2) has or will have direct contact with students

Then you have "covered" employees for purposes of completing the attached form.

TIPS recommends all vendors consult their legal counsel for guidance in compliance with this law. If you have questions on how to comply, see below. If you have questions on compliance with this code section, contact the Texas Department of Public Safety Non-Criminal Justice Unit, Access and Dissemination Bureau, FAST-FACT at NCJU@txdps.state.tx.us and you should send an email identifying you as a contractor to a Texas Independent School District or ESC Region 8 and TIPS. Texas DPS phone number is (512) 424-2474.

See form in the next attribute to complete entitled:
Texas Education Code Chapter 22 Contractor Certification for Contractor Employees

Texas Education Code Chapter 22 Contractor Certification for Contractor Employees

Introduction: Texas Education Code Chapter 22 requires entities that contract with school districts to provide services to obtain criminal history record information regarding covered employees. Contractors must certify to the district that they have complied. Covered employees with disqualifying criminal histories are prohibited from serving at a school district.

Definitions: Covered employees: Employees of a contractor or subcontractor who have or will have continuing duties related to the service to be performed at the District and have or will have direct contact with students. The District will be the final arbiter of what constitutes direct contact with students. Disqualifying criminal history: Any conviction or other criminal history information designated by the District, or one of the following offenses, if at the time of the offense, the victim was under 18 or enrolled in a public school:

(a) a felony offense under Title 5, Texas Penal Code; (b) an offense for which a defendant is required to register as a sex offender under Chapter 62, Texas Code of Criminal Procedure; or (c) an equivalent offense under federal law or the laws of another state.

I certify that:

NONE (Section A) of the employees of Contractor and any subcontractors are covered employees, as defined above. If this box is checked, I further certify that Contractor has taken precautions or imposed conditions to ensure that the employees of Contractor and any subcontractor will not become covered employees. Contractor will maintain these precautions or conditions throughout the time the contracted services are provided.

OR

SOME (Section B) or all of the employees of Contractor and any subcontractor are covered employees. If this box is checked, I further certify that:

(1) Contractor has obtained all required criminal history record information regarding its covered employees. None of the covered employees has a disqualifying criminal history.

(2) If Contractor receives information that a covered employee subsequently has a reported criminal history, Contractor will immediately remove the covered employee from contract duties and notify the District in writing within 3 business days.

(3) Upon request, Contractor will provide the District with the name and any other requested information of covered employees so that the District may obtain criminal history record information on the covered employees.

(4) If the District objects to the assignment of a covered employee on the basis of the covered employee's criminal history record information, Contractor agrees to discontinue using that covered employee to provide services at the District.

Noncompliance or misrepresentation regarding this certification may be grounds for contract termination.

None

7 **Texas Business and Commerce Code § 272 Requirements as of 9-1-2017**

4 SB 807 prohibits construction contracts to have provisions requiring the contract to be subject to the laws of another state, to be required to litigate the contract in another state, or to require arbitration in another state. A contract with such provisions is voidable. Under this new statute, a "construction contract" includes contracts, subcontracts, or agreements with (among others) architects, engineers, contractors, construction managers, equipment lessors, or materials suppliers. "Construction contracts" are for the design, construction, alteration, renovation, remodeling, or repair of any building or improvement to real property, or for furnishing materials or equipment for the project. The term also includes moving, demolition, or excavation. BY RESPONDING TO THIS SOLICITATION, AND WHEN APPLICABLE, THE PROPOSER AGREES TO COMPLY WITH THE TEXAS BUSINESS AND COMMERCE CODE § 272 WHEN EXECUTING CONTRACTS WITH TIPS MEMBERS THAT ARE TEXAS GOVERNMENT ENTITIES.

7 **Texas Government Code 2270 Verification Form**

5 Texas Government Code 2270 Verification Form
Texas 2017 House Bill 89 has been signed into law by the governor and as of September 1, 2017 will be codified as Texas Government Code § 2270 and 808 et seq.
The relevant section addressed by this form reads as follows:
Texas Government Code Sec. 2270.002. PROVISION REQUIRED IN CONTRACT. A governmental entity may not enter into a contract with a company for goods or services unless the contract contains a written verification from the company that it: (1) does not boycott Israel; and (2) will not boycott Israel during the term of the contract. engaged by ESC Region 8/The Interlocal Purchasing System (TIPS)
4845 Highway 271 North
Pittsburg, TX, 75686
verify by this writing that the above-named company affirms that it (1) does not boycott Israel; and (2) will not boycott Israel during the term of this contract, or any contract with the above-named Texas governmental entity in the future. I further affirm that if our company's position on this issue is reversed and this affirmation is no longer valid, that the above-named Texas governmental entity will be notified in writing within one (1) business day and we understand that our company's failure to affirm and comply with the requirements of Texas Government Code 2270 et seq. shall be grounds for immediate contract termination without penalty to the above-named Texas governmental entity.
AND
our company is not listed on and we do not do business with companies that are on the the Texas Comptroller of Public Accounts list of Designated Foreign Terrorists Organizations per Texas Gov't Code 2270.0153 found at <https://comptroller.texas.gov/purchasing/docs/foreign-terrorist.pdf>

I swear and affirm that the above is true and correct.

YES

**7
6** Logos and other company marks

Please upload your company logo to be added to your individual profile page on the TIPS website. If any particular specifications are required for use of your company logo, please upload that information under the "Logo and Other Company Marks" section under the "Response Attachment" tab. Preferred Logo Format: 300 x 225 px - .png, .eps, .jpeg preferred

Potential uses of company logo:

* Your Vendor Profile Page of TIPS website

* Potentially on TIPS website scroll bar for Top Performing Vendors

* TIPS Quarterly eNewsletter sent to TIPS Members

* Co-branding Flyers and or email blasts to our TIPS Members (Permission and approval will be obtained before publishing)

**7
7** Solicitation Deviation/Compliance

Does the vendor agree with the General Conditions Standard Terms and Conditions or Item Specifications listed in this proposal invitation?

Yes

**7
8** Solicitation Exceptions/Deviations Explanation

If the bidder intends to deviate from the General Conditions Standard Terms and Conditions or Item Specifications listed in this proposal invitation, all such deviations must be listed on this attribute, with complete and detailed conditions and information included or attached.

TIPS will consider any deviations in its proposal award decisions, and TIPS reserves the right to accept or reject any bid based upon any deviations indicated below or in any attachments or inclusions.

In the absence of any deviation entry on this attribute, the proposer assures TIPS of their full compliance with the Standard Terms and Conditions, Item Specifications, and all other information contained in this Solicitation.

No response

**7
9** Agreement Deviation/Compliance

Does the vendor agree with the language in the Vendor Agreement?

Yes

**8
0** Agreement Exceptions/Deviations Explanation

If the proposing Vendor desires to deviate from the Vendor Agreement language, all such deviations must be listed on this attribute, with complete and detailed conditions and information included. TIPS will consider any deviations in its proposal award decisions, and TIPS reserves the right to accept or reject any proposal based upon any deviations indicated below. In the absence of any deviation entry on this attribute, the proposer assures TIPS of their full compliance with the Vendor Agreement.

No response

8 1 Felony Conviction Notice

Texas Education Code, Section 44.034, Notification of Criminal History, Subsection (a), states “a person or business entity that enters into a contract with a school district must give advance notice to the district if the person or an owner or operator of the business entity has been convicted of a felony. The notice must include a general description of the conduct resulting in the conviction of a felony.” Subsection (b) states “a school district may terminate a contract with a person or business entity if the district determines that the person or business entity failed to give notice as required by Subsection (a) or misrepresented the conduct resulting in the conviction. The district must compensate the person or business entity for services performed before the termination of the contract.” (c) This section does not apply to a publicly held corporation. The person completing this proposal certifies that they are authorized to provide the answer to this question.

Select A., B. or C.

A. My firm is a publicly held corporation; therefore, this reporting requirement is not applicable.

OR B. My firm is not owned nor operated by anyone who has been convicted of a felony, OR

C. My firm is owned or operated by the following individual(s) who has/have been convicted of a felony. (if you answer C below, you are required to provide information in the next attribute.

B. Firm not owned nor operated by felon; per above

8 2 If you answered C. My Firm is owned or operated by a felon to the previous question, you are REQUIRED TO ANSWER THE FOLLOWING QUESTIONS.

If you answered C. My Firm is owned or operated by a felon to the previous question, you must provide the following information.

- 1. Name of Felon(s)
- 2. The named person's role in the firm, and
- 3. Details of Conviction(s).

No response

8 3 Long Term Cost Evaluation Criterion # 4.

READ CAREFULLY and see in the RFP document under "Proposal Scoring and Evaluation". Points will be assigned to this criterion based on your answer to this Attribute. Points are awarded if you agree not to increase your catalog prices (as defined herein) more than X% annually over the previous year for years two and three and potentially year four, unless an exigent circumstance exists in the marketplace and the excess price increase which exceeds X% annually is supported by documentation provided by you and your suppliers and shared with TIPS, if requested. If you agree NOT to increase prices more than 5%, except when justified by supporting documentation, you are awarded 10 points; if 6% to 14%, except when justified by supporting documentation, you receive 1 to 9 points incrementally. Price increases 14% or greater, except when justified by supporting documentation, receive 0 points.

7-29-2021 RP rescored for maximum increase percentage . score for Long term costs was adjusted from 10 to 0 points to permit increases over 5% to over 14% as proposed due to market conditions during covid crisis. adjusted score is 83.

increases will be 5% or less annually per question

8 4 Required Confidentiality Claim Form

Required Confidentiality Claim Form

This completed form is required by TIPS. By submitting a response to this solicitation you agree to download from the “Attachments” section, complete according to the instructions on the form, then uploading the completed form, with any confidential attachments, if applicable, to the “Response Attachments” section titled “Confidentiality Form” in order to provide to TIPS the completed form titled, “CONFIDENTIALITY CLAIM FORM”. By completing this process, you provide us with the information we require to comply with the open record laws of the State of Texas as they may apply to your proposal submission. If you do not provide the form with your proposal, an award will not be made if your proposal is qualified for an award, until TIPS has an accurate, completed form from you.

Read the form carefully before completing and if you have any questions, email Rick Powell at TIPS at rick.powell@tjps-usa.com

85 Choice of Law clauses with TIPS Members

If the vendor is awarded a contract with TIPS under this solicitation, the vendor agrees to make any Choice of Law clauses in any contract or agreement entered into between the awarded vendor and with a TIPS member entity to read as follows: "Choice of law shall be the laws of the state where the customer resides" or words to that effect.

86 Venue of dispute resolution with a TIPS Member

In the event of litigation or use of any dispute resolution model when resolving disputes with a TIPS member entity as a result of a transaction between the vendor and TIPS or the TIPS member entity, the Venue for any litigation or other agreed upon model shall be in the state and county where the customer resides unless otherwise agreed by the parties at the time the dispute resolution model is decided by the parties.

87 Automatic renewal of contracts or agreements with TIPS or a TIPS member entity

This clause **DOES NOT** prohibit multiyear contracts or agreements with TIPS member entities. Because TIPS and TIPS members are governmental entities subject to laws that control appropriations of funds during their fiscal years for contracts and agreements to provide goods and services, does the Vendor agree to limit any automatic renewal clauses of a contract or agreement executed as a result of this TIPS solicitation award to not longer than "month to month" and at the TIPS contracted rate.

88 Indemnity Limitation with TIPS Members

Texas and other states restrict by law or state Constitution the ability of a governmental entity to indemnify others. TIPS requires that any contract entered into between a vendor and TIPS or a TIPS Member as a result of an award under this Solicitation limit the requirement that the Customer indemnify the Vendor by either eliminating any such indemnity requirement clauses in any agreements, contracts or other binding documents **OR** by prefacing all indemnity clauses required of TIPS or the TIPS Member entity with the following: "To the extent permitted by the laws or the Constitution of the state where the customer resides, ".

Agreement is a required condition to award of a contract resulting from this Solicitation.

89 Arbitration Clauses

Except for certain circumstances, TIPS forbids a mandatory arbitration clause in any contract or agreement entered into between the awarded vendor with TIPS or a TIPS member entity. Does the vendor agree to exclude any arbitration requirement in any contracts or agreement entered into between TIPS or a TIPS member entity through an awarded contract with TIPS?

CERTIFICATION BY CORPORATE OFFERER

**COMPLETE ONLY IF OFFERER IS A CORPORATION,
THE FOLLOWING CERTIFICATE SHOULD BE EXECUTED AND INCLUDED AS PART OF
PROPOSAL FORM/PROPOSAL FORM.**

OFFERER: CLS Sewer Equipment Co. Inc.
(Name of Corporation)

Jennifer Sonnier certify that I am the Secretary of the Corporation
I, (Name of Corporate Secretary)

named as OFFERER herein above; that

Jerry P. Sonnier II
(Name of person who completed proposal document)

who signed the foregoing proposal on behalf of the corporation offerer is the authorized person that is acting as

President
(Title/Position of person signing proposal/offer document within the corporation)

of the said Corporation; that said proposal/offer was duly signed for and in behalf of said corporation by authority of its governing body, and is within the scope of its corporate powers.



CORPORATE SEAL if available

Jennifer Sonnier
SIGNATURE

12-20-19
DATE

TIPS RFP # _____

Required Confidential Information Status Form

CONFIDENTIAL INFORMATION SUBMITTED IN RESPONSE TO COMPETITIVE PROCUREMENT REQUESTS OF EDUCATION SERVICE CENTER REGION 8 AND TIPS (ESC8) IS GOVERNED BY TEXAS GOVERNMENT CODE, CHAPTER 552

If you consider any portion of your proposal to be confidential information and not subject to public disclosure pursuant to Chapter 552 Texas Gov't Code or other law(s), you **must attach a copy of all claimed confidential materials within your proposal and put this COMPLETED form as a cover sheet to said materials then scan, name "CONFIDENTIAL" and upload with your proposal submission.** (You must include all the confidential information in the submitted proposal. The copy uploaded is to indicate which material in your proposal, if any, you deem confidential in the event the receives a Public Information Request.) ESC8 and TIPS will follow procedures of controlling statute(s) regarding any claim of confidentiality and shall not be liable for any release of information required by law. Upon your claim and your defense to the Office of Texas Attorney General is required to make the final determination whether the information submitted by you and held by ESC8 and TIPS is confidential and exempt from public disclosure.

C.S. Sewer Equipment Co. Inc.
Name of company

Jerry Sonnier President
Printed Name and Title of authorized company officer declaring below the confidential status of material

700 S. Sherman St Richardson TX 75081 972-479-1335
Address City State ZIP Phone

ALL VENDORS MUST COMPLETE THE ABOVE SECTION.

I DO CLAIM parts of my proposal to be confidential and DO NOT desire to expressly waive a claim of confidentiality of all information contained within our response to the solicitation. The attached contains material from our proposal that I classify and deem confidential under Texas Gov't Code Sec. 552 or other law(s) and I invoke my statutory rights to confidential treatment of the enclosed materials.

ATTACHED ARE COPIES OF _____ PAGES OF CLAIMED CONFIDENTIAL MATERIAL FROM OUR PROPOSAL THAT WE DEEM TO BE NOT PUBLIC INFORMATION AND WILL DEFEND THAT CLAIM TO THE TEXAS ATTORNEY GENERAL IF REQUESTED WHEN A PUBLIC INFORMAITON REQUEST IS MADE FOR OUR PROPOSAL.

Signature _____ Date _____

OR -----

I DO NOT CLAIM any of my proposal to be confidential, complete the section below.

Express Waiver: I desire to expressly waive any claim of confidentiality as to any and all information contained within our response to the competitive procurement process (e.g. RFP, CSP, Bid, RFQ, etc.) by completing the following and submitting this sheet with our response to Education Service Center Region 8 and TIPS.

Signature [Signature] Date 12-20-19



MATHIEU
FAYAT GROUP

NEW
MB 210



GOING THE TRA MILE



Our new MC 210 platform is the culmination of over 90 years' experience in the field of cleaning, comprising four different solutions: pure sweeping, versatile sweeping, brushing and washing.

In a world where comfort, reliability, performance and respect for the environment are the minimum requirement today, the new MC 210 sets new standards in urban cleanliness...

- A pure and functional design...
- A comfortable and spacious cab...
- Useful and intuitive technologies...
- Enhanced performance...
- Dedicated and tailor-made cleaning solutions...
- An environmentally-friendly approach...

Our new AZURA and AZURA FLEX sweeping solutions offer all this!



FUNCTIONAL DESIGN

The characteristic curves of the previous generation have gone; the new AZURA MC 210 sports a modern urban design which enhances the image of cleanliness. With its extra-compact dimensions, this sweeper blends into the urban environment.

- Streamlined style
- Relevant volumes
- A cab which combines design and practicality





COMFORT

360° view

The passenger compartment of the new AZURA MC 210 makes its mark with its extra-high and extra-low windscreen, with its glass-panelled side doors, panoramic and wide-angle mirrors, rear-view quarter panels, floor window, suction nozzle and rear view cameras.

At the wheel, you are completely in control of your environment and enjoy a dominant position and an unsurpassed 360° view.

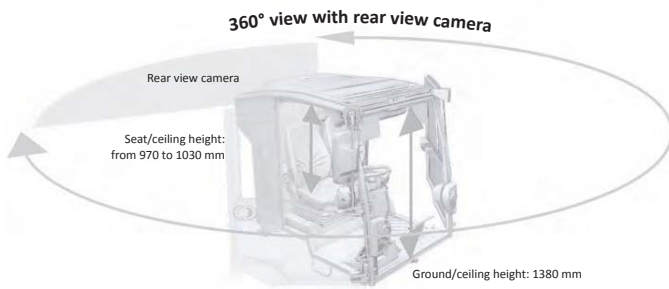

Luxury driving

Space has been freed up, giving the driver and passenger an extra 20% of room. The passenger compartment has been de-cluttered for greater comfort. The driving position can be adjusted to all body shapes thanks to the enhanced cab, and a wide range of seat and steering column settings.

These excellent ergonomics thus reduce joint and muscle tension. Combined with a calm environment, the overall feeling is one of well-being.



Designed for on-board comfort

You can now perform your sweeping tasks in a first-class environment thanks to the quality control equipment and a dashboard designed to optimise organisation at the driving position :

- Standard automatic air conditioning
- Foot-level heating
- Driver and passenger suspended seats with multiple settings and 3-point seatbelts
- Passenger foot-rest
- MP3-SD-USB Bluetooth radio with hands-free kit
- 12V plug with smartphone compartment
- Cup holder
- Rear view camera
- Suction nozzle camera



USEFUL TECHNOLOGY

A user-friendly, intuitive screen

Ergonomically built into the middle of the dashboard, the 7-inch multi-function colour screen with quality graphics can accompany you whilst operating the sweeper, and even afterwards.

The screen offers a number of services and promotes a dialogue between the machine and the operator, offers easier and quick maintenance for technicians and better monitoring of daily operation for managers.

- Real-time surveillance of active functions,
- Log book to access useful operational data (hours worked, distances travelled, average consumption, etc.),
- An integrated diagnostic help tool,
- A function to extract operational data and to update via USB stick,
- A PDF file reader.



Travel mode



Work mode with indicator lights on



Data logbook

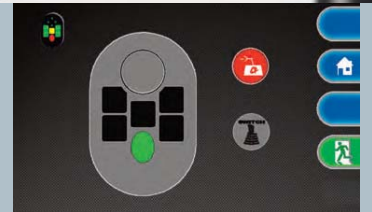

Diagnostic help tool



Intuitive work controls

The AZURA MC 210 features new and innovative work controls, managed by CANBus. This technology, used in our equipment for 10 years, has been redesigned to revolutionise your sweeping approach thanks to its ease of use.

The new **keypads** have short pressure buttons with backlit display, each one representing a function symbolised by an icon and a colour code. Utilising this technology, you can activate and deactivate the sweeping mode simply by pressing the **Start & Sweep** button.

The single multi-function joystick allows the driver to control movements more accurately.

This technology is focused on the operator's needs.



Quality is apparent in the details. The predecessor offered unrivalled performance on all fields; the AZURA MC 210 exceeds the qualities which made the previous generation so successful.

Innovative PPS sweeping system

The innovative **Push and Pull System** offers multiple fields of application thanks to its integrated searching system. Its independent control of the brushes provides advantages similar to a three-brush solution (handling, access to remote areas, etc.).

The brushes are mounted on a rotary cylinders – patented technology – which increases the sweeping system's functionality and its operating potential and makes it possible to reach a maximum sweeping range of 2450 mm.

Optimised power at low speed

Thanks to the new hydraulic system with dedicated functions, an extra-wide reinforced suction nozzle and large-diameter high-resistance direct suction pipe, suction power is improved by nearly 10% at low speed and the cooling capacity is enhanced to guarantee suitability for all environments.

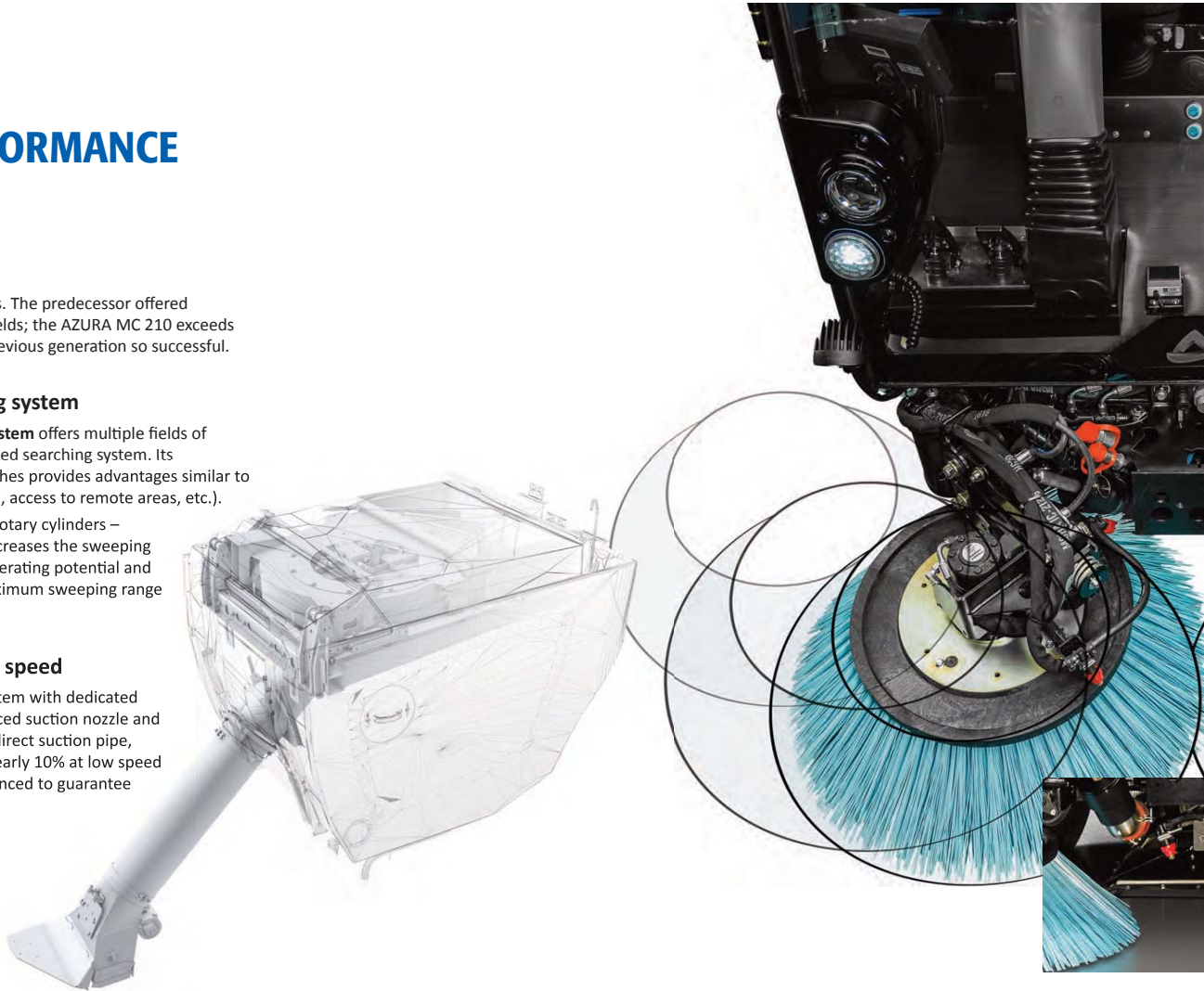

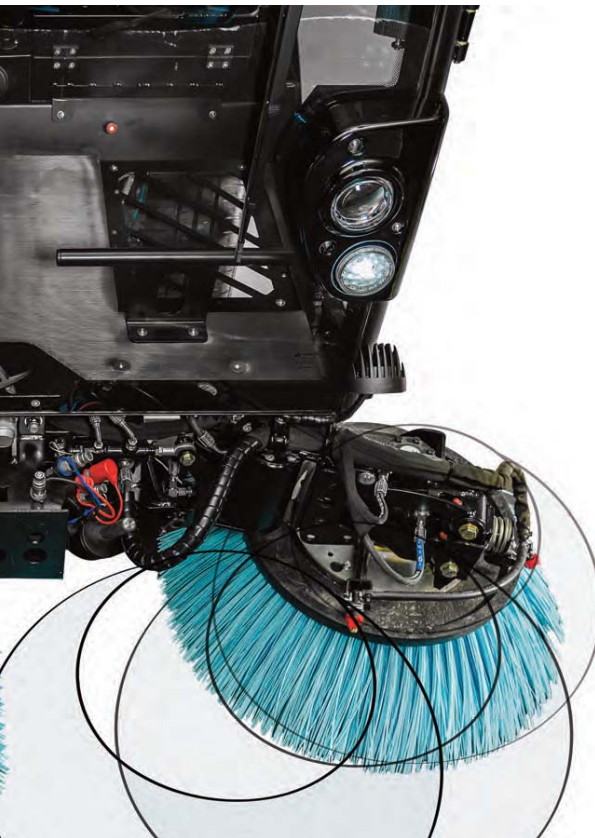

A manoeuvrability in line with the demands of the city

With its extra-compact dimensions, small rear overhang, 2 or 4 wheel steering in sweeping mode and an optimised turning radius, the AZURA MC 210 can easily negotiate obstacles and can be manoeuvred with great agility through narrow streets. The urban environment is definitely its favourite playground.

In travel mode, the **Auto-Steer** function, which automatically realigns the rear axle, allows the operator to stay focused on his task and to quickly and safely get from one working zone to another.

Proven chassis

A large capacity stainless steel 4016 hopper, reinforced chassis, resized rear axle with safe load capacity of 3.5 tonnes and 16-inch premium wheels offer **payload capacities of + 400 kg.**

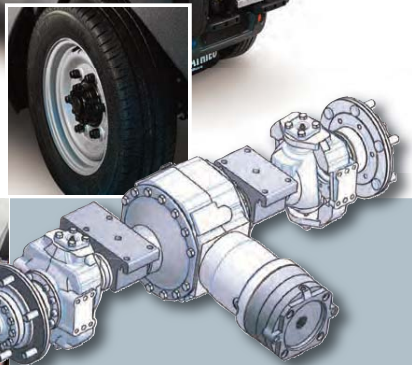
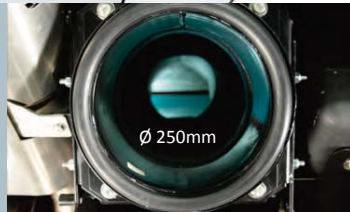



In the city, no task is too challenging

The AZURA FLEX is the essence of flexibility; being the 5-in-1 tool-sweeper version of the AZURA.

Designed to be in action all year round thanks to its remarkable performance and flexibility, it will meet all your needs in terms of urban viability in all seasons, more than any other solution.

With the standard front arrangement, it becomes a three-brush sweeping solution, a mechanical weeding solution, a brushing/scouring, washing or snow removal solution.

It takes less than 5 minutes to install the different tools. It is therefore easy for the operator and doesn't require specific machines for the various tasks.



- **A third robust and efficient brush** for an even better performance. For mechanical weeding operations, treatment of cluttered or inaccessible zones, this solution will appeal to you due to its extended efficiency and speed.

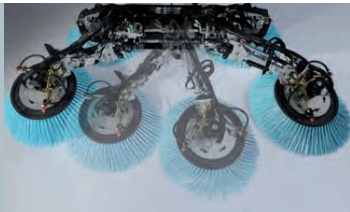

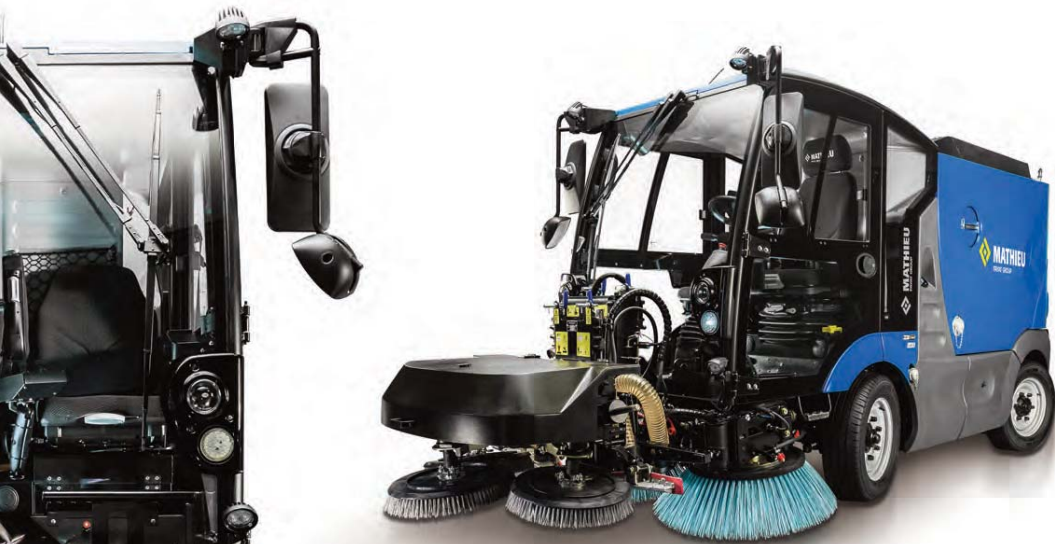

- An innovative brushing and scouring unit comprising 3 brushes, combined with a system for collecting waste water will allow you to renovate any type of porous or smooth floor (paving stones, marble, natural stone, etc.). Thanks to its integrated detergent tank fitted with a precise dosing system, all you will leave behind is a genuine impression of cleanliness.

- A washing kit, fitted with high-pressure pump, front-installed removable cleaning spray-bar with two side jets and a nozzle coupled with an automatic hose reel, will be essential for your washing operations.



3 SOLUTIONS FOR WINTER VIABILITY

- A 200-litre salt spreader with direct spreading or circular gritter disc - the dosage is set in the cab (optional) via a control unit.
- Rotating snow removal brush installed at the front of the AZURA FLEX. This acts in addition to the spreader at the rear to carry out efficient and complete snow removal from the road and sidewalks.
- A robust snow removal blade for easy snow removal thanks to hydraulic adjustment of the blade left and right.



ENVIRONMENTALLY RESPONSIBLE

The AZURA MC 210 thinks of tomorrow, now

Offering a clean environment every day is the basis of our activity. Our eco-responsible approach ensures well-being and comfort for operators and residents.

An eco-efficient working mode

The new AZURA MC 210 has three pre-defined working speeds to handle the different sweeping tasks which the operator encounters daily: an **EcoMode**, a standard mode and a **BoostMode** limited to 10 minutes of use.



EcoMode

80% of common sweeping tasks are handled with EcoMode.

Activation of this working mode leads to:

- Up to 50% fuel savings compared to an intensive working mode,
- Less noise pollution,
- Preserving the lifetime of your sweeper.



Reducing clean water consumption

Thanks to the option of recycling waste water re-injected into the suction nozzle, added to a precise and proportional dose of clean water sprayed onto the brushes and in the nozzle, you can significantly reduce your clean water requirements.



3 stars in the EUnited PM10 test

The MC 210 reached the maximum score in the standardised EUnited PM 10 test. This is the guarantee of choosing a sweeper with the lowest release of airborne particulates!



Recyclable sweepers

Constructed from 90% steel, cast iron, aluminium, copper and glass, the mechanical and hydraulic components of the MC 210 platform are entirely recyclable. The plastic parts are also able to be recycled by specialists.

EURO 6

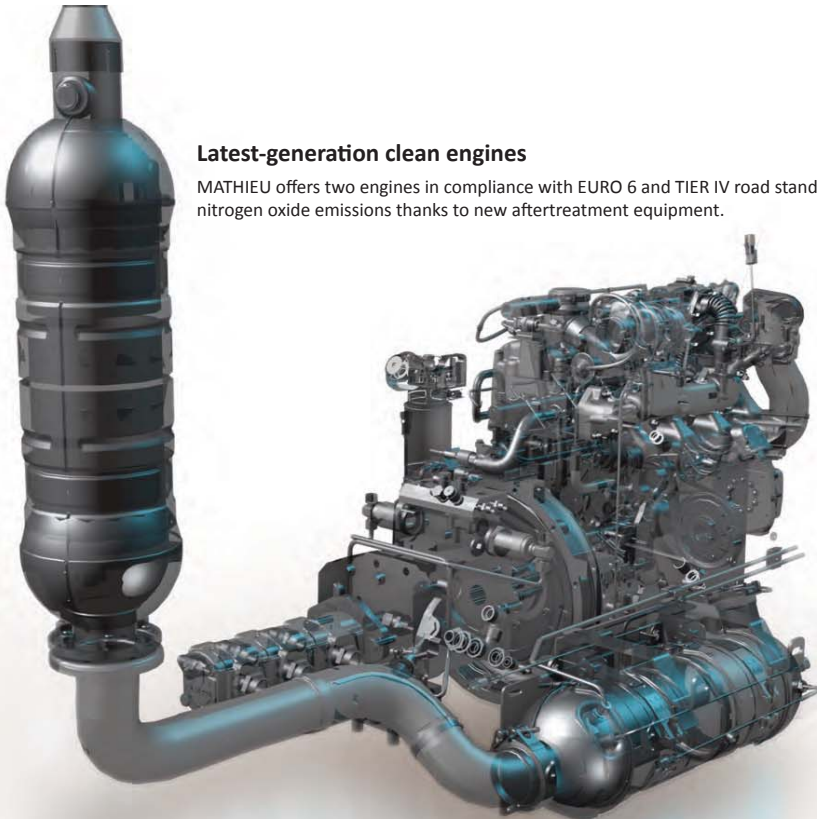

Latest-generation clean engines

MATHIEU offers two engines in compliance with EURO 6 and TIER IV road standards, which largely reduce particle and nitrogen oxide emissions thanks to new aftertreatment equipment.

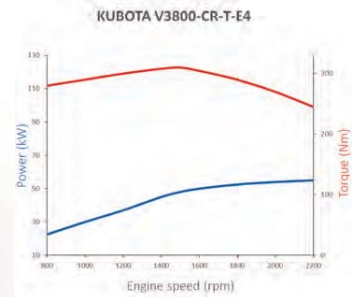

-20% fuel consumption

The new pre-defined working speeds coupled with the new engines allow for fuel savings of up to 20%.



-20% CO2 emissions

Thanks to the reduced fuel requirement, the CO2 rate is significantly reduced.



Low noise pollution

Thanks to the effi-silence technology, reduced-noise engines and the selection of quality sound-proofing materials, the sweepers' level of acoustic power and pressure has been reduced.



EQUIPMENT AND OPTIONS

	AZURA	AZURA Flex
COMFORT		
Removable central fleece armrest	•	•
Climate control	•	•
Adjustable foot-level heating	•	•
Document holder	•	•
Coat hook	•	•
Cup holder	•	•
Passenger-side footrest	•	•
Wide-angle rear-view brush mirrors	•	•
Class II panoramic wing mirrors	•	•
Class II panoramic heated wing mirrors, electrically adjustable from the cabin	○	○
Driver seat suspended mechanically with multiple settings and headrest with 3-point seatbelt	•	•
Driver seat suspended electro-pneumatically with multiple settings and headrest with 3-point seatbelt	○	○
Passenger seat suspended mechanically with multiple settings and headrest with 3-point seatbelt	•	•
Roller sun blind (driver and passenger)	•	•
AUDIO		
Smartphone compartment	•	•
Hands-free kit (integrated into the radio)	•	•
12V plug	•	•
MP3 - USB - SD - Bluetooth radio	•	•
7" DISPLAY		
Speedometer	•	•
Logbook	•	•
Diagnostic help tool	•	•
Datas extraction and update via USB	•	•
WORK FUNCTIONS		
Two-brush sweeping with integrated PPS system	•	•
Camera on nozzle	•	•
Main working controls integrated into the door console	•	•
Brush lighting with LED	•	•
Blocking of nozzle trap in the up position	•	•
Potentiometer to adjust the pressure and relief of the side brushes	•	•
Potentiometer to adjust the rotating speed of the side brushes	•	•
Potentiometer to adjust the speed of the front tool	X	•
Recycling of waste water in the suction nozzle	○	○
Adjustment of the tilt of the brushes from the cabin (right + left)	○	○
Rapid lift of the nozzle / brush unit	•	•
Activation and deactivation of the sweeping mode with Start & Sweep	•	•
Independent proportional water valve for dampening the nozzle and the brushes	•	•
DRIVING		
Right stalk	•	•
Intermittent windscreen wipers	•	•
Self-cancelling turning indicators	•	•
STEERING		
2 or 4 steer wheels in working mode	•	•
2 front steer wheels in travel mode	•	•
Automatic alignment of rear wheels, Auto Steer	•	•
16" wheels and 225/65 tyres	•	•

	AZURA	AZURA Flex
SECURITY		
Activation of brake lights when decelerating	•	•
Reflective strip (white and red), Cat. II	○	○
Emergency stop button	•	•
ON/OFF button for the rotating warning light	•	•
Rear view camera	•	•
2 kg powder extinguisher	•	•
LED daytime running lights	•	•
LED working lights mounted on top of the cab	○	○
LED low and high beam head-lights	○	○
LED rotating beacon on the cab roof	•	•
2 nd LED rotating beacon on the rear of the hopper	○	○
Rear step	•	•
MAINTENANCE		
Spare wheel (separate)	○	○
5-tonne jack	○	○
Automatic centralised greasing	○	○
Manual centralised greasing	○	○
Tool kit	○	○
WORK TOOLS		
Manual cleaning dome (2 rotating jets) with coupling trolley at the rear	○	○
15 m automatic hose reel fitted to the front of the machine (not compatible with a 3rd brush)	○	X
15 m automatic hose reel fitted to the rear on an articulated frame	○	○
360° washing attachment fitted on the roof of the container with 15 m automatic hose reel and nozzle	○	○
Additional 240 litre clean water tank (total water capacity of 540 litre)	○	○
High-pressure system (20L/min at 150 bar), 5m of hose and nozzle	○	○
Leaf suction hose (150 mm diameter) with support frame at the rear of the machine (Not compatible with the additional water tank)	○	○
3 rd brush mounted on a geared rail with quick fastening system	X	○
3 rd weeding brush: specific weeding brush and anti-projection bib	X	○
1,50 m-wide snow brush, 420 mm diameter brush with left/right hydraulic adjustment	X	○
Brushing kit with 3 brushes with waste water suction system and 20 litre detergent tank	X	○
Washing kit including an automatic hose reel with 15 m hose, a high-pressure nozzle, a cleaning spray-bar that can be manually adjusted up and down, left and right, and two side jets to wash under cars and benches	X	○
Snow blade, 1.40 m wide, left and right hydraulic adjustment, rubber scraper, signalling flag	X	○
Salt-spreader 200-litre volume, adjustable spreading range from 1 to 6 m via a circular gritter disc, signalling light ramp with fog and reversing lights	X	○
Salt-spreader 200-litre volume, spreading range set at 1.40 m, signalling light ramp with fog and reversing lights	X	○
Hydraulic lifting system for brushing, blade and snow blade unit.	X	○

Key: standard = • optional = ○ unavailable = X

DIMENSIONS & CHARACTERISTICS

Chassis	
Travel speed (kph)	25 to 50 (depending on local regulations)
Working speed (kph)	0- 15
Steering	2 or 4 steer wheels in working mode
Front and rear suspensions	leaf springs
Front brakes	Disc brakes with dual braking system
Rear brakes	Hydraulic brakes + drum brakes (optional)

Engines	EURO 6	TIER IV /STAGE IIIb
Make / Type	VM R754 EU6 Common rail direct injection turbocharged diesel engine	KUBOTA V3800-CR-T-E4 direct injection turbocharged diesel engine
After treatment	Exhaust line with catalyst (DOC) and particle filter (DPF) + Selective Catalytic Reduction system (SCR) with AdBlue injection (14 liter tank)	Exhaust system with catalyst (DOC) and particle filter (DPF)
Cubic capacity	2 970 cm ³	3 800 cm ³
Number of cylinders	4	4
Maximum power	62 kW @ 2 300 rpm (83 BHP)	55,4 kW @ 2 200 rpm (74 BHP)
Maximum couple	270 Nm @ 1 350 rpm	310 Nm @ 1 500 rpm

Dimensions, weight, capacities	
Length (mm)	3 845 (Azura) / 3 965 (Azura Flex)
Width (mm) (without mirrors)	1 280
Height (mm) (without rotating beacon)	2 096
Seat height (mm) (from seat to ceiling)	970 - 1 030
GVW (kg)	5 000
Wheelbase (mm)	2 150
Maximum weight on front axle (kg)	2 500
Maximum weight on rear axle (kg)	2 500
Fuel tank capacity (liters)	70
Clean water tank capacity (liters)	300 (540 option)
Recycled water tank capacity (liters)	250 (option)
Turning radius curb to curb (mm)	3 150
Turning radius wall to wall (mm)	3 700
Gradeability (%)	Up to 28

Waste Hopper	
Voided volume (m ³)	2
Payload (kg)	1 500 (depending on the options)
Material	4016 stainless steel
Dumping height (mm)	1 400

Sweeping system	
Sweeping width (mm)	1 280 - 2 450 (2 700 with 3 rd brush)
Number of brushes	2 or 3 (option)
Brush diameter (mm)	900

Suction system	
Blower capacity (m ³ /h)	13 000
Suction nozzle dimensions (mm)	540 x 200
Suction tube diameter (mm)	250

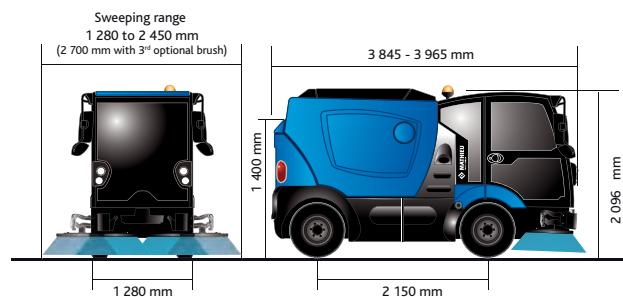



MATHIEU S.A.
85, rue Sébastien Choulette
B.P. 32 54202 Toul Cedex
France

T : +33 (0) 3 83 65 22 22
F : +33 (0) 3 83 63 19 82
E : info@mathieu.fayat.com

www.mathieu.fayat.com

Distributed by



MATHIEU
FAYAT GROUP

NEW
MB 210





MATHIEU S.A.
85, rue Sébastien Choulette
B.P. 32 54202 Toul Cedex
France

T : +33 (0) 3 83 65 22 22
F : +33 (0) 3 83 63 19 82
E : info@mathieu.fayat.com

www.mathieu.fayat.com



SCARAB SWEEPERS LIMITED
Pattenden Lane, Marden,
Tonbridge, Kent - TN12 9QD
United Kingdom

T +44 (0) 1622 831 006
F +44 (0) 1622 832 417

www.scarab-sweepers.com

Distributed by



RAVO
FAYAT GROUP

RAVO 5 iSeries



50 YEARS OF EXPERIENCE PASSIONATE ABOUT SWEEPING

Since we invented the pure vacuum compact street sweeper 50 years ago over 15,000 RAVO have been sold to customers all over the world. These customers include cities like Rome, Barcelona, Portland, Dubai, Montreal, Washington DC, Bordeaux, Berlin and Amsterdam to name a few. All these cities have chosen, and keep on choosing RAVO because of our commitment to build the greatest sweeper in the world.

Whether it is about the possible uptime of over 95% or the potential 42% fuel savings compared to a truck mounted sweeper, we deliver on all levels. And that attitude has made the RAVO 5 iSeries sweeper into what it is today: World's most sold sweeper.

RAVO goes back a long way in North America. It was in 1983 that the first RAVO was sold to a municipality of Hilton NY, many machines followed soon after. Since 2009 RAVO has become part of the family owned FAYAT Group (parent of BOMAG and Cedar Rapids) and we have set our focus on North America once more.

In North America we have established a growing network of well recognized distributors and have service technicians on the ground who are there to assist you and give you all the backup you need so you can focus on what you are good at: keeping your roads clean.



DESIGNED TO PERFORM THE RAVO 5 iSERIES



SETTING NEW STANDARDS

With a choice between Tier 3 and Tier 4 final engines, a new attractive cabin interior design and a state of the art intelligent sweeper monitoring system the new 5 iSeries sets the new benchmark in sweeping.

The unmatched performance is the result of a pure vacuum suction line combined with RAVO's unique broom system.

Spring or Autumn, sand with pine needles or leaves, ring roads or bicycle lanes, smooth tarmac or cobblestones, the 5 iSeries will clean every street in one pass. Storing all debris in its spacious 6.5 cubic yard stainless steel hopper with an unrivaled compaction rate.

Every RAVO is standard equipped with:

- An ergonomically designed cabin with adjustable steering column, dashboard and arm rest

- Rear view and suction mouth camera
- Air conditioning
- Air ride operator seat
- Stainless steel hopper with a volume up to 6.5 cu yd.
- Loading capacity of 12,125 lbs.
- Extreme manoeuvrability with a turning circle of only 199 inch.(curb to curb)
- RAVO's unique pulled broom system:
 - Constant brush pressure extends the broom life with 50%
 - Maintenance friendly: no greasing points.
- One engine powers all: fuel savings up to 42%
- Hydraulic front suspension with automatic levelling system
- Linde hydraulics
- Only 15 greasing points on the whole machine.



THE NEW ISYSTEM: INTELLIGENCE MEETS CONVENIENCE

At RAVO we continuously improve and develop our products. The new RAVO intelligent electronic monitoring system, which we named the iSystem, is an excellent example of our latest innovation. It has been specially developed to be in full control of your sweeper.

This new & robust control system has been exhaustively tested to meet the high RAVO standards. The use of nodes guarantees stability and the built in LCD screen enables you to check the electrical & hydraulic system.

This system will ease maintenance of your machine by informing you the status of the functionalities of your sweeper

At one glance you can view all functions of the sweeper. Via the various available screens you can for example keep track of your sweeping and engine hours, service intervals or check your hydraulic system, lights, gauges, various pressure and voltage levels, etc.

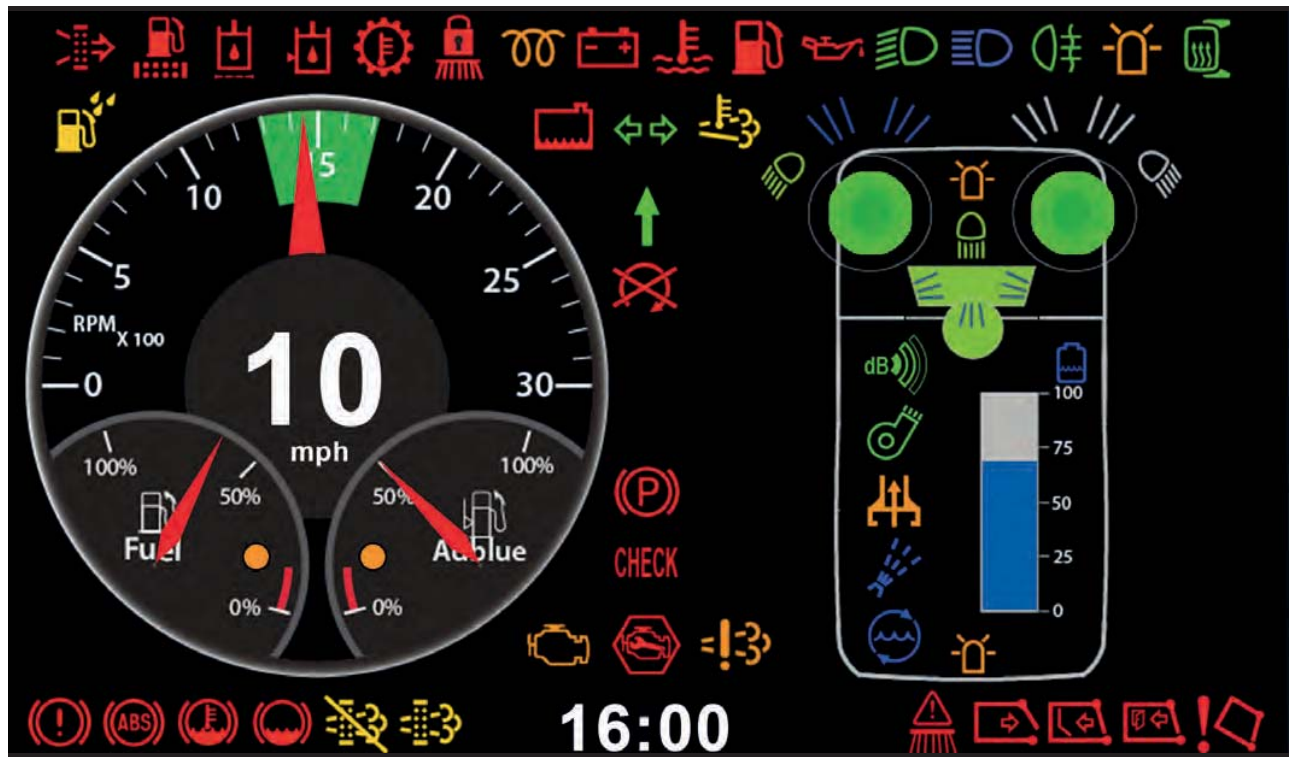

Sweeping mode

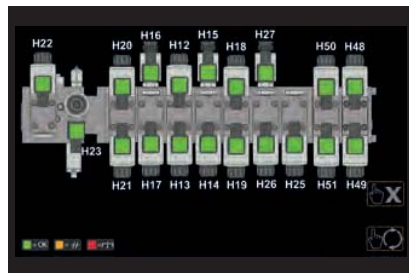

Diagnostic mode

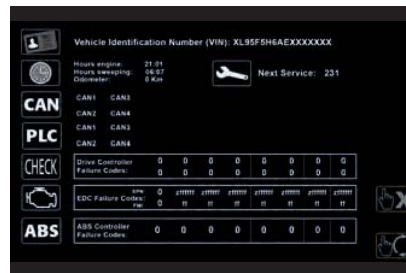

Info mode



Parameter mode



THE NEW CABIN ATTRACTIVE & COMFORTABLE

The new cabin has been designed with the input of experienced international RAVO operators. When entering the cabin with a floor height of only 31 inches, you will notice the ample interior space. Once seated in the air ride operator's seat the logical layout of the dashboard will amaze you. Add to that the fully adjustable armrest and steering wheel, the slightly tilted panoramic windscreen for ultimate visibility and you will agree that new standards have been set. These standards include:

- iSystem
- Sound isolation
- Panoramic view
- Adjustable steering column, dashboard and arm rest
- Rear view and suction mouth camera
- Air-conditioning
- 12V plug
- Radio with MP3 and USB
- 2 Cup holders.
- Lockable storage space
- Hatch to the hopper



EASE OF MAINTENANCE

To ensure proper maintenance of the machine in a smart way the RAVO 5 iSeries comes with the following features:

- RAVO's unique maintenance friendly brush system
- Fan cleaner
- Two big service doors for easy access
- Easy changeable brushes
- Liftable grid inside the hopper
- High pressure water pump.

RAVO 5 iSeries, INNOVATION KEEPS YOU GOING









A VERSATILE PERFORMER

For those who need specific requirements RAVO offers a range of options to customize your RAVO 5 iSeries. Below are some examples of the available options.

Container dump

This option allows you to dump your debris directly into a container and has a dumping height of 5 ft. 5in

Third brush/Weed cutter

The third brush increases the sweeping range of the RAVO 5 iSeries. This option enables drivers to clean pavements and road gutters more efficiently. When used in combination with the weed cutter brush, it is extremely suitable for the environmental friendly removal of weeds. This option can be equipped with a 'quick release' feature, which allows quick removal or installation of the third brush.

Heavy duty package

Equip your sweeper with a coated suction line to extend its lifetime when working under the heaviest conditions.

High pressure water pump

The high pressure water pump feature is perfect for quickly cleaning the inside of the container, brush and suction system or street furniture.

Brush angle adjustment

With the brush angle adjustment you can position the brushes into the optimal angle to sweep gutters, which makes sweeping more efficient.

Independent brush lifting

The independent brush lifting enables you to reduce brush wear and achieve a longer lifetime of the brushes.

Swasher installation

Sweep and spray roads and pavements in just one go. The pressurized swasher allows sweeping crews to clean the most difficult reachable places, street furniture and traffic signs. Various configurations in terms of water pressure, water tanks and pumps are available.

Water recycling

This option doubles your action radius and reduces dust emission at the same time.

Wander hose

The wander hose is perfect for sucking up leaves and for emptying gutters and waste bins.

Silent package

The silent package reduces the noise level of the RAVO 5 iSeries by 15%. The package includes special software, sound absorbing materials and special silent brushes.





RAVO 5 iSeries: MADE IN HOLLAND

Being Europe's number one producer of street sweeping machines and having 50 years of experience makes RAVO a true specialist in the sweeping branch. We have the know-how and skills to meet your wishes. The RAVO 5 iSeries is build according to Dutch standards; high quality, robustness, superior technology and innovative design.



RAVO: YOUR PREFERRED PARTNER

Together with our certified and dedicated dealer network we help you exceed your expectations and overcome all challenges.

We know that your equipment must work 24/7. To proof our trust in the quality of our product we offer a standard warranty of two years or 2000 hours on every sweeper that leaves our factory. On top of that we offer a 5 year warranty on the container and chassis.



RAVO GENUINE PARTS, DESIGNED TO FIT!



At RAVO we understand the importance of uptime. Therefore all our North American distributors carry a large stock of RAVO genuine parts. The right part is just a phone call away.

Genuine RAVO parts are produced according to the highest standards of quality, durability and performance that is why they are such a good match for your RAVO sweeper

To assure you always have the right parts available for scheduled service we have composed various service and parts kits, it's that easy!

Using RAVO Genuine Parts means:

- Receiving 12 Months warranty on parts
- Meeting the OEM specifications
- Increase the lifetime of your RAVO sweeper
- Always the right fit
- Cost savings over the long run.

For more information you can contact your local dealer who has RAVO trained parts specialists with the right knowledge and experience to assist you. They can further inform you about the possibilities of full service contracts and other service and maintenance options.

RAVO ACADEMY

Training & education is highly valued by RAVO. Whether it is training of our employees and dealers or your operators and engineers. We have different training programs which are available at our own training facility. This is the RAVO Academy.

The RAVO academy enables our dealers and their customers to use and maintain the RAVO sweepers in the most efficient way. This high quality training facility at the RAVO factory in Alkmaar provides trainings on different skill levels.

Our professional RAVO trainers also offer training on location, either at the dealer or at the customer.

Contact your local dealer for more information regarding the training possibilities.



RAVO 5 iSeries TECHNICAL SPECIFICATIONS

Dimensions, Weight, Capacities	
Length	178 inch
Width incl mirrors	89 inch
Sweeping width	95 inch
Max. sweeping width incl. third brush	134 inch
Wheelbase	71.5 inch
Turning radius curb to curb	199 inch
Gradeability [%]	Up to 30%
Gross vehicle weight	25,132 lbs
Capacity fuel tank	28 gal
Capacity water tank	160 gal
Suction system	
Capacity blower	14,000 CFM
Suction nozzle dimensions l x w	4.7 x 24.8 inch
Suction nozzle material	Corten steel (optional linatex lining available)
Suction tube diameter	8.9 inch
Suction tube material	Stainless Steel (optional linatex lining available)
Broom system	
Type	RAVO maintenance free pulling brush system
Available broom diameter	35 inch
Broom rotation speed	0 - 210 rpm
Well-being	
Noise emission LWA	79 dBA at 50 feet distance
Dust filtration	EUnited PM10 Certified*
Brakes & Electricity	
Front brakes	Hydraulically operated disk brakes
Rear brakes	Hydrostatic hydraulically actuated servo drum brakes
Front suspension	Independent hydro-pneumatic suspension
Rear suspension	Rubber cone springs
Battery	2 x 12 / 72
Alternator	90 amperes
Voltage (V)	24, with running engine 28
Maintenance	
Container Material	Stainless Steel inside / ABS cover outside
Total amount of greasing points in sweeper	15
Warranty	2 years or 2000 engine hours whichever comes first
Optional Equipment	
Wander hose	8 inch diameter
Third broom/Weed cutter	Mounted in front: 30 inch diameter
Silent package Lwa	65 dBA at 50 feet distance
High pressure water pump	4 gal per min. @ 2,175 PSI
Camera	Suction mouth, side view and rearview
Extra water capacity	Up to 400 Gallon

Engine & Drive system	Emission level Tier 3	Emission level Tier 4 final
Engine type	Iveco N45 ENT Diesel 4 Cyl.	Cummins QSF3.8 Diesel 4 Cyl.
Displacement	4.5 L	3.8 L
Maximum torque	413 lb.ft @ 1400 rpm	360 lb.ft @ 1600 rpm
Maximum power	141 hp @ 2200 rpm	138 hp @ 2300 rpm
RAVO drive type and drive line system	Linde / Hydrostatic Continuously Variable	Linde / Hydrostatic Continuously Variable

*Special package

RAVO 5 iSeries TECHNICAL SPECIFICATIONS

Standard



Gross volume	6.5 cu yd
Net volume	5.6 cu yd
Height	106 inch
Dumping height	3.3 ft
Total empty weight (curb weight)	13,110 lbs
Payload	12,125 lbs

Container dump



Gross volume	5 cu yd.
Net volume	4.3 cu yd
Height	98 inch
Dumping height	5.3 ft
Total empty weight (curb weight)	13,580 lbs
Payload	11,570 lbs

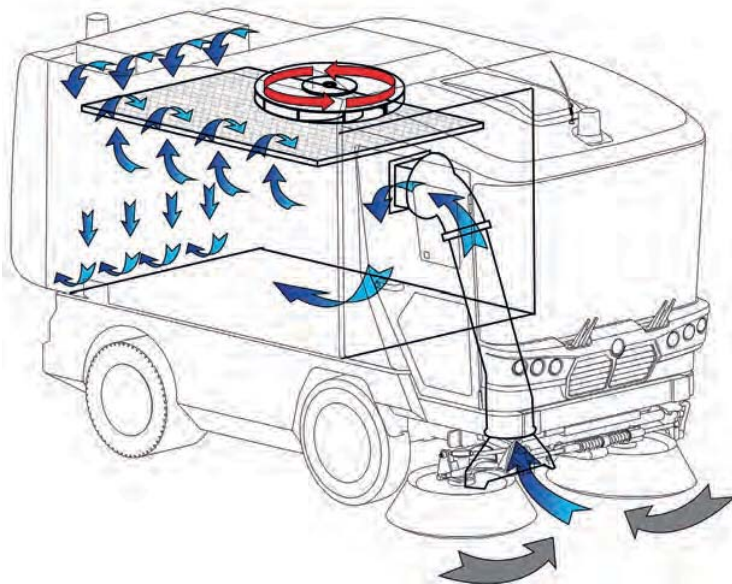

**RAVO'S PURE VACUUM
CLEANER PRINCIPLE**
SINCE 1964

Every effort has been made to ensure that the information in this brochure is accurate. RAVO B.V. is not responsible for printing or clerical errors.



RAVO B.V.
P.O. Box 286, 1800 AG Alkmaar
Otterkoog 1, 1822 BW Alkmaar
The Netherlands

T +31 (0) 72 567 32 32
F +31 (0) 72 567 32 00

www.ravo.fayat.com

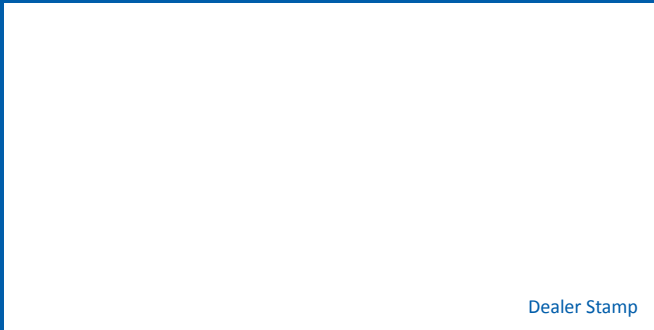

Dealer Stamp