

TIPS VENDOR AGREEMENT

Between GNP Energy LED and
(Company Name)

THE INTERLOCAL PURCHASING SYSTEM (TIPS)

For

PART 2 – RCSP 180203 Renewable Energy and Solar Solutions and Services

General Information

The Vendor Agreement (“Agreement”) made and entered into by and between The Interlocal Purchasing System (hereinafter referred to as “TIPS” respectfully) a government cooperative purchasing program authorized by the Region 8 Education Service Center, having its principal place of business at 4845 US Hwy 271 North, Pittsburg, Texas 75686. This Agreement consists of the provisions set forth below, including provisions of all Attachments referenced herein. In the event of a conflict between the provisions set forth below and those contained in any Attachment, the provisions set forth shall control.

The vendor Agreement shall include and incorporate by reference this Agreement, the terms and conditions, special terms and conditions, any agreed upon amendments, as well as all of the sections of the solicitation as posted, including any addenda and the awarded vendor’s proposal. Once signed, if an awarded vendor’s proposal varies or is unclear in any way from the TIPS Agreement, TIPS, at its sole discretion, will decide which provision will prevail. Other documents to be included are the awarded vendor’s proposals, task orders, purchase orders and any adjustments which have been issued. If deviations are submitted to TIPS by the proposing vendor as provided by and within the solicitation process, this Agreement may be amended to incorporate any agreed deviations.

The following pages will constitute the Agreement between the successful vendors(s) and TIPS. Bidders shall state, in a separate writing, and include with their proposal response, any required exceptions or deviations from these terms, conditions, and specifications. If agreed to by TIPS, they will be incorporated into the final Agreement.

A Purchase Order, Agreement or Contract is the TIPS Member’s approval providing the authority to proceed with the negotiated delivery order under the Agreement. Special terms and conditions as agreed to between the vendor and TIPS Member should be added as addenda to the Purchase Order, Agreement or Contract. Items such as certificate of insurance, bonding requirements, small or disadvantaged business goals are some of the addenda possible.

Terms and Conditions

Freight

All quotes to members shall provide a line item for cost for freight or shipping regardless if there is a charge or not. If no charge for freight or shipping, indicate by stating "No Charge" or "\$0" or other similar indication.

Warranty Conditions

All new supplies equipment and services shall include manufacturer's minimum standard warranty unless otherwise agreed to in writing. Vendor shall be legally permitted to sell, or an authorized dealer, distributor or manufacturer for all products offered for sale to TIPS Members. All equipment proposed shall be new unless clearly stated in writing.

Customer Support

The Vendor shall provide timely and accurate customer support to TIPS Members. Vendors shall respond to such requests within one (1) working day after receipt of the request. Vendor shall provide training regarding products and services supplied by the Vendor unless otherwise clearly stated in writing at the time of purchase. (Unless training is a line item sold or packaged and must be purchased with product.)

Agreements

All Agreements and agreements between Vendors and TIPS Members, unless otherwise agreed by the parties, shall strictly adhere to the statutes that are set forth in the Uniform Commercial Code as most recently revised for the jurisdiction of the TIPS Member.

Agreements for purchase will normally be put into effect by means of a contract, agreement or purchase order(s) executed by authorized agents of the participating government entities.

Davis Bacon Act requirements will be met when Federal Funds are used for construction and/or repair of buildings or as otherwise required by applicable statute or regulation.

Other Wage Rates may be required by some TIPS Members and acceptance of a projects by the Vendor may require the Vendor to comply with the TIPS Member's required wage rate.

Tax exempt status

A taxable item sold, leased, rented to, stored, used, or consumed by any of the following governmental entities is exempted from the taxes imposed by this chapter:(1) the United States; (2) an unincorporated instrumentality of the United States; (3) a corporation that is an agency or instrumentality of the United States and is wholly owned by the United States or by another corporation wholly owned by the United States;(4) the State of Texas; (5) a Texas county, city, special district, or other political subdivision; or (6) a state, or a governmental unit of a state that borders Texas, but only to the extent that the other state or governmental unit exempts or does not impose a tax on similar sales of items to this state or a political subdivision of this state. Texas Tax Code § 151.309. Most TIPS Members are tax exempt and the related laws of the jurisdiction of the TIPS Member shall apply.

Page 2 of 12

Assignments of Agreements

No assignment of Agreement may be made without the prior written approval of TIPS. Payment can only be made to the awarded Vendor or vendor assigned dealer.

Disclosures

1. Vendor affirms that he/she has not given, offered to give, nor intends to give at any time hereafter any economic opportunity, future employment, gift, loan, gratuity, special discount, trip, favor or service to a public servant in connection with this Agreement.
2. Vendor shall attach, in writing, a complete description of any and all relationships that might be considered a conflict of interest in doing business with Members in the TIPS program.
3. The vendor affirms that, to the best of his/her knowledge, the offer has been arrived at independently, and is submitted without collusion with anyone to obtain information or gain any favoritism that would in any way limit competition or give an unfair advantage over other vendors in the award of this Agreement.

Renewal of Agreements

The Agreement with TIPS is for one (2) year with an option for renewal for additional two (2) consecutive year. Total term of Agreement can be up to the number of years provided in the solicitation or as limited by statute. The option renewal year one shall be automatically renewed unless either party objects or terminates the agreement as provided herein at "**Termination for Convenience**".

No Agreement for goods or services with a TIPS Member by the awarded vendor named in this Agreement that results from the solicitation award named in this Agreement, may incorporate an automatic renewal clause with which the TIPS Member must comply. All renewal terms incorporated in an Agreement by the vendor with the TIPS Member shall only be valid and enforceable when the vendor receives written confirmation by purchase order or executed Agreement issued by the TIPS Member for any renewal period. The purpose of this clause is to avoid a TIPS Member inadvertently renewing an Agreement during a period in which the governing body of the TIPS Member has not properly appropriated and budgeted the funds to satisfy the Agreement renewal. This term is not negotiable and any Agreement between a TIPS Member and a TIPS awarded vendor with an automatic renewal clause that conflicts with these terms is rendered void and unenforceable.

Shipments

The Vendor shall ship ordered products within a commercially reasonable time after the receipt of the order. If a product cannot be shipped within that time, the Vendor shall notify TIPS and the requesting entity as to why the product has not shipped and shall provide an estimated

Page 3 of 12

shipping date, if applicable. TIPS or the requesting entity may cancel the order if estimated shipping time is not acceptable.

Invoices

The awarded vendor shall submit invoices or payment requests to the TIPS Member participating entity clearly stating "Per TIPS Agreement # xxxxxxx. Each invoice or pay request shall include the TIPS Member's purchase order number or other identifying designation as provided in the order by the TIPS Member. If applicable, the shipment tracking number or pertinent information for verification of TIPS Member receipt shall be made available upon request. The Vendor or vendor assigned dealer shall not invoice for partial shipments unless agreed to in writing in advance by TIPS and the TIPS Member.

Payments

The TIPS Member will make payments directly to the Vendor or vendor assigned dealer at net 30 days after receiving invoice or in compliance with applicable statute, whichever is the lessor time or as otherwise provided by an agreement of the parties.

Pricing

The Vendor agrees to provide pricing to TIPS and its participating governmental entities that is at least equal to the lowest pricing available to like cooperative purchasing customers and the pricing shall remain so throughout the duration of the Agreement. Price increases will be honored according to the terms of the solicitation. However, the Vendor shall honor previous prices for thirty (30) days after written notification to TIPS of an increase, except any price changes related to the, then current, RS Means Unit Price Book is valid. Price of a specific Job Order Contract proposal to a TIPS Member shall not change within 60 days of date of proposal as a result of an updated RS Means Unit Price Book unless agreed by the TIPS Member. All pricing submitted to TIPS shall include the participation fee, as provided in the solicitation, to be remitted to TIPS by the Vendor. Vendor will not show adding the fee to the invoice presented to customer. Failure to render the participation fee to TIPS shall constitute a breach of this agreement and shall be grounds for termination of this agreement and any other agreement held with TIPS.

Participation Fees

Vendor or vendor assigned dealer Agreements to pay the participation fee for all Agreement sales to TIPS on a monthly scheduled report. Vendor must login to the TIPS database and use the "Submission Report" section to report sales. The Vendor or vendor assigned dealers are responsible for keeping record of all sales that go through the TIPS Agreement. Failure to pay the participation fee will result in termination of Agreement. Please contact TIPS at tips@tips-usa.com or call (866) 839-8477 if you have questions about paying fees.

Indemnity

The Vendor agrees to indemnify and hold harmless and defend TIPS, TIPS Member(s), officers and employees from and against all claims and suits by third parties for damages, injuries to persons (including death), property damages, losses, and expenses including court costs and reasonable attorney's fees, arising out of, or resulting from, Vendor's work under this Agreement, including all such causes of action based upon common, constitutional, or statutory law, or based in whole or in part, upon allegations of negligent or intentional acts on the part of the Vendor, its officers, employees, agents, subcontractors, licensees, or invitees. Vendor further agrees to indemnify and hold harmless and defend TIPS, TIPS Member(s), officers and employees, from and against all claims and suits by third parties for injuries (including death) to an officer, employee, agent, subcontractors, supplier or equipment lessee of the Vendor, arising out of, or resulting from, Vendor's work under this Agreement whether or not such claims are based in part upon the negligent acts or omissions of the TIPS, TIPS Member(s), officers, employees, or agents.

Multiple Vendor Awards

TIPS reserves the right to award multiple vendor Agreements per Texas Government Code §2269 for categories when deemed in the best interest of the TIPS Membership. Bidders scoring the solicitation's specified minimum score or above will be considered for an award. Categories are established at the discretion of TIPS.

State of Texas Franchise Tax

By signature hereon, the bidder hereby certifies that he/she is not currently delinquent in the payment of any franchise taxes owed the State of Texas under Chapter 171, Tax Code.

Miscellaneous

The Vendor acknowledges and agrees that continued participation in TIPS is subject to TIPS sole discretion and that any Vendor may be removed from the participation in the Program at any time with or without cause. Nothing in the Agreement or in any other communication between TIPS and the Vendor may be construed as a guarantee that TIPS Members will submit any orders at any time. TIPS reserves the right to request additional proposals for items or services already on Agreement at any time.

Purchase Order Pricing/Product Deviation

If a deviation of pricing/product on a purchase order or contract modification occurs, TIPS is to be notified within 48 hours of receipt of order.

Termination for Convenience

TIPS reserves the right to terminate this agreement for cause or no cause for convenience with a thirty-day written notice. Termination for convenience is required under Federal Regulations

actual termination of this agreement shall be honored at the option of the TIPS Member. The awarded vendor may terminate the agreement with ninety (90) days written notice to TIPS 4845 US Hwy North, Pittsburg, Texas 75686.

TIPS Member Purchasing Procedures

Purchase orders or their equal are issued by participating TIPS Member to the awarded vendor indicating on the PO "Agreement Number". Order is emailed to TIPS at tipspo@tips-usa.com.

- Awarded vendor delivers goods/services directly to the participating member.
- Awarded vendor invoices the participating TIPS Member directly.
- Awarded vendor receives payment directly from the participating member.
- Awarded vendor reports sales monthly to TIPS (unless prior arrangements have been made with TIPS to report monthly).

Form of Agreement and Reporting

If a vendor submitting an offer requires TIPS and/or TIPS Member to sign an additional agreement, a copy of the proposed agreement must be included with the proposal.

In response to submitted supplemental Vendor Agreement documents, TIPS will review proposed vendor Agreement documents. Vendor's Agreement document shall not become part of TIPS's Agreement with vendor unless and until an authorized representative of TIPS reviews and approves it. TIPS does not require a review a TIPS Member's Job Order contract AIA version or other construction contract, but may, if requested by the Member.

This clause does not relieve the Vendor from the responsibility to report the contract execution and the amount of the contract and any change orders.

Licenses

Awarded vendor shall maintain in current status all federal, state and local licenses, bonds and permits required for the operation of the business conducted by awarded vendor. Awarded vendor shall remain fully informed of and in compliance with all ordinances and regulations pertaining to the lawful provision of services under the Agreement. TIPS reserves the right to stop work and/or cancel Agreement of any awarded vendor whose license(s) expire, lapse, are suspended or terminated.

Novation

If awarded vendor sells or transfers all assets or the entire portion of the assets used to perform this Agreement, a successor in interest must guarantee to perform all obligations under this Agreement. TIPS reserves the right to accept or reject any new party. A simple change of name agreement will not change the Agreement obligations of awarded vendor.

Cleanup: Awarded vendor shall clean up and remove all debris and rubbish resulting from their work as required or directed by TIPS Member. Upon completion of work, the premises shall be left in good repair and an orderly, neat, clean and unobstructed condition.

Preparation: Awarded vendor shall not begin a project for which TIPS Member has not prepared the site, unless awarded vendor does the preparation work at no cost, or until TIPS Member includes the cost of site preparation in a purchase order.

Site preparation includes, but is not limited to: moving furniture, installing wiring for networks or power, and similar pre-installation requirements.

Registered sex offender restrictions: For work to be performed at schools, awarded vendor agrees that no employee of a sub-contractor who has been adjudicated to be a registered sex offender will perform work at any time when students are or reasonably expected to be present. Awarded vendor agrees that a violation of this condition shall be considered a material breach and may result in the cancellation of the purchase order at the TIPS Member's discretion. Awarded vendor must identify any additional costs associated with compliance of this term. If no costs are specified, compliance with this term will be provided at no additional charge. Safety measures: Awarded vendor shall take all reasonable precautions for the safety of employees on the worksite, and shall erect and properly maintain all necessary safeguards for protection of workers and the public. Awarded vendor shall post warning signs against all hazards created by the operation and work in progress. Proper precautions shall be taken pursuant to state law and standard practices to protect workers, general public and existing structures from injury or damage.

Smoking

Persons working under Agreement shall adhere to local smoking policies. Smoking will only be permitted in posted areas or off premises.

Marketing

Awarded vendor agrees to allow TIPS to use their name and logo within website, marketing materials and advertisement. Any use of TIPS name and logo or any form of publicity, inclusive of press release, regarding this Agreement by awarded vendor must have prior approval from TIPS.

Supplemental agreements

The TIPS Member entity participating in the TIPS Agreement and awarded vendor may enter into a separate supplemental agreement or contract to further define the level of service requirements over and above the minimum defined in this Agreement i.e. invoice requirements, ordering requirements, specialized delivery, etc. Any supplemental agreement or contract developed as a result of this Agreement is exclusively between the participating entity and awarded vendor. TIPS, its agents, TIPS Members and employees shall not be made party to any claim for breach of such agreement.

Survival Clause

All applicable software license agreements, warranties or service agreements that were entered into between Vendor and Customer under the terms and conditions of the Agreement shall survive the expiration or termination of the Agreement. All Orders, Purchase Orders issued or contracts executed by TIPS or a TIPS Member and accepted by the Vendor prior to the expiration or termination of this agreement, shall survive expiration or termination of the Agreement, subject to previously agreed terms and conditions agreed by the parties or as otherwise specified herein relating to termination of this agreement.

Legal obligations

It is the responding vendor's responsibility to be aware of and comply with all local, state and federal laws governing the sale of products/services identified in this Solicitation and any awarded Agreement thereof. Applicable laws and regulations must be followed even if not specifically identified herein.

Audit rights

Due to transparency statutes and public accountability requirements of TIPS and TIPS Members', the awarded Vendor shall, at their sole expense, maintain appropriate due diligence of all purchases made by TIPS Member that utilizes this Agreement. TIPS and Region 8 ESC each reserve the right to audit the accounting of TIPS related purchases for a period of three (3) years from the time such purchases are made. This audit right shall survive termination of this Agreement for a period of one (1) year from the effective date of termination. In order to ensure and confirm compliance with this agreement, TIPS shall have authority to conduct random audits of Awarded Vendor's pricing that is offered to TIPS Members. Notwithstanding the foregoing, in the event that TIPS is made aware of any pricing being offered to eligible entities that is materially inconsistent with the pricing under this agreement, TIPS shall have the ability to conduct the audit internally or may engage a third-party auditing firm to investigate any possible non-complying conduct. In the event of an audit, the requested materials shall be reasonably provided in the format and at the location designated by Region 8 ESC or TIPS.

Force Majeure

If by reason of Force Majeure, either party hereto shall be rendered unable wholly or in part to carry out its obligations under this Agreement then such party shall give notice and fully particulars of Force Majeure in writing to the other party within a reasonable time after occurrence of the event or cause relied upon, and the obligation of the party giving such notice, so far as it is affected by such Force Majeure, shall be suspended during the continuance of the inability then claimed, except as hereinafter provided, but for no longer period, and such party shall endeavor to remove or overcome such inability with all reasonable dispatch.

When applicable, performance bonds and payment bonds will be required on construction or labor required jobs. Awarded vendor will meet the TIPS Member's local and state purchasing requirements. Awarded vendors may need to provide additional capacity as jobs increase. Bonds will not require that a fee be paid to TIPS. The actual cost of the bond will be a pass through to the TIPS Member and added to the purchase order or Agreement.

Professional Engineering and Architect's Services

Professional Engineering and Architect's Services are not permitted to be provided under this Agreement. Texas statutes prohibit the procurement of Professional Engineering and Architect's Services through a cooperative agreement.

Scope of Services

The specific scope of work for each job shall be determined in advance and in writing between TIPS Member, Member's design professionals and Vendor. It is permitted for the TIPS Member to provide a general scope description, but the awarded vendor should provide a written scope of work, and if applicable, according to the TIPS Member's design Professional as part of the proposal. Once the scope of the job is agreed to, the TIPS Member will issue a PO and/or an Agreement or Contract with the Job Order Contract Proposal referenced or as an attachment along with bond and any other special provisions agreed by the TIPS Member. If special terms and conditions other than those covered within this solicitation and awarded Agreements are required, they will be attached to the PO and/or an Agreement or Contract and shall take precedence over those in this base TIPS Vendor Agreement.

Project Delivery Order Procedures

The TIPS Member having approved and signed an interlocal agreement, or other TIPS Membership document, may make a request of the awarded vendor under this Agreement when the TIPS Member has services that need to be undertaken. Notification may occur via phone, the web, email, fax, or in person. Upon notification of a pending request, the awarded vendor shall make contact with the TIPS Member as soon as possible, but must make contact with the TIPS Member within two working days.

Scheduling of Projects

Scheduling of projects (if applicable) will be accomplished when the TIPS Member issues a Purchase Order and/or an Agreement or Contract that will serve as "the notice to proceed" as agreed by the Vendor and the TIPS Member. The period for the delivery order will include the mobilization, materials purchase, installation and delivery, design, weather, and site cleanup and inspection. No additional claims may be made for delays as a result of these items. When the tasks have been completed the awarded vendor shall notify the client and have the TIPS Member or a designated representative of the TIPS Member inspect the work for acceptance under the scope and terms in the Purchase Order and/or Agreement or Contract.

The TIPS Member will issue in writing any corrective actions that are required. Upon completion of these items, the TIPS Member will issue a completion notice and final payment will be issued per the contractual requirements of the project with the TIPS Member.

Support Requirements

If there is a dispute between the awarded vendor and TIPS Member, TIPS or its representatives will assist in conflict resolution or third party (mandatory mediation), if requested by either party. TIPS, or its representatives, reserves the right to inspect any project and audit the awarded vendors TIPS project files, documentation and correspondence.

Incorporation of Solicitation

The TIPS Solicitation, whether a Request for Proposals, the Request for Competitive Sealed Proposals or Request for Qualifications solicitation, the Vendor's response to same and all associated documents and forms made part of the solicitation process, including any addenda, that resulted in the execution of this agreement are hereby incorporated by reference into this agreement as if copied verbatim.

SECTION HEADERS OR TITLES

THE SECTION HEADERS OR TITLES WITHIN THIS DOCUMENT ARE MERELY GUIDES FOR CONVENIENCE AND ARE NOT FOR CLASSIFICATION OR LIMITING OF THE RESPONSIBILITIES OF THE PARTIES TO THIS DOCUMENT.

NEW STATUTORY REQUIREMENT EFFECTIVE SEPTEMBER 1, 2017.

You certify that your company (1) does not boycott Israel; and (2) will not boycott Israel during the term of the Agreement. Texas governmental entities are prohibited from doing business with companies that fail to certify to this condition as required by Texas Government Code Sec. 2270.

You certify that your company is not listed on and we do not do business with companies that are on the Texas Comptroller of Public Accounts list of Designated Foreign Terrorists Organizations per Texas Gov't Code 2270.0153 found at <https://comptroller.texas.gov/purchasing/docs/foreign-terrorist.pdf>

You certify that pursuant to Texas Business and Commerce Code Chapter 272, as revised September 1, 2017, any construction contract or agreement as defined in the Statute with a TIPS, Education Service Center Region 8 or a Texas TIPS Member subject to the Statute shall include a Choice of Law provision providing that this agreement shall be subject to and interpreted by the Laws of the State of Texas without regard to any conflict of laws principles for any action shall be in a court of competent jurisdiction in Texas and any arbitration shall be in the State of Texas.

Page 10 of 12

Pursuant to the Texas Business and Commerce Code, as amended by the 85th Texas Legislature, this Construction Agreement for Job Order Contract services is, in the event of a dispute between the parties, subject to interpretation according to the Laws of the state of Texas only, without regard to any conflict of laws principles. Venue for any alternative dispute resolution procedure or process shall be in the state of Texas. If the dispute is litigated, venue and jurisdiction shall be in a court of competent jurisdiction in the state of Texas.

Pursuant to 85th Texas Legislative H.B. 3270, as it applies to Texas Education Code § 22.0834 et seq, the Vendor shall comply with all relevant sections related to student contact, background checks, fingerprinting and other related requirements.

Special Terms and Conditions

It is the intent of TIPS to award to reliable, high performance vendors to supply products and services to government and educational agencies. It is the experience of TIPS that the following procedures provide TIPS, the Vendor, and the participating agency the necessary support to facilitate a mutually beneficial relationship.

- **Agreements:** All vendor purchase orders and/or Agreements/Contracts must be emailed to TIPS at tipspo@tips-usa.com. Should an agency send an order direct to vendor, it is the vendor's responsibility to forward the order to TIPS at the email above within 24 business hours and confirm its receipt with TIPS.
 - **Promotion of Agreement:** It is agreed that Vendor will encourage all eligible entities to purchase from the TIPS Program. Encouraging entities to purchase directly from the Vendor and not through TIPS Agreement is a violation of the terms and conditions of this Agreement and will result in removal of the Vendor from the TIPS Program.
-

Page 12 of 12 will be the TIPS Vendor Agreement Signature Page

TIPS Vendor Agreement Signature Form

PART 2 – RCSP 180203 Renewable Energy and Solar Solutions and Services
Part 2 installation and construction on site considered a Public Work (JOC)

Company Name GNP Energy LED

Address 17000 Alico Commerce CT #103

City FT Myers State FL Zip 33967

Phone 312-970-1533 Fax 866-286-1588

Email of Authorized Representative mark.fiacable@gnpenergy.com

Name of Authorized Representative Mark Fiacable

Title VP Sales and Marketing

Signature of Authorized Representative *Mark Fiacable*

Date 3-9-218

TIPS Authorized Representative Name Meredith Barton

Title Vice-President of Operations

TIPS Authorized Representative Signature *Meredith Barton*

Approved by ESC Region 8 *David Wayne Fitta*

Date 4/26/18

The Interlocal Purchasing System (TIPS Cooperative) Supplier Response

Bid Information		Contact Information		Ship to Information
Bid Creator	Rick Powell General Counsel/Procurement Compliance Officer	Address	Region VIII Education Service Center 4845 US Highway 271 North Pittsburg, TX 75686	Address
Email	rick.powell@tips-usa.com	Contact	Kristie Collins, Contracts Compliance Specialist	Contact
Phone	(903) 575-2689			Department
Fax				Building
Bid Number	180203			Floor/Room
Title	Renewable Energy and Solar Solutions and Services (2 PART)	Department		Telephone
		Building		Fax
Bid Type	RFP			Email
Issue Date	2/1/2018 08:02 AM (CT)	Floor/Room		
Close Date	3/16/2018 03:00:00 PM (CT)	Telephone	+1 (866) 839-8477	
		Fax	+1 (866) 839-8472	
		Email	bids@tips-usa.com	

Supplier Information

Company	GNP Energy LED (Great Northern Processing Corp.)
Address	17010 Alico Commerce CT unit 202 FT Myers, FL 33967
Contact	Mark Fiacable
Department	
Building	
Floor/Room	
Telephone	(312) 970-1533
Fax	(866) 286-1588
Email	mark.fiacable@gnpenergy.com
Submitted	3/13/2018 03:53:41 PM (CT)
Total	\$0.00

By submitting your response, you certify that you are authorized to represent and bind your company.

Signature Mark Fiacable

Email info@gnpenergy.com

Supplier Notes

Bid Notes

This is a two part solicitation for 180203 Renewable Energy and Solar Solutions and Services. Part 1 is for equipment and services including installations that are not considered a public work and Part 2 is for installation services that are public work construction related projects, such as, but not limited to, electrical or plumbing requiring engineering.

Bid Activities

Bid Messages

Bid Attributes

Please review the following and respond where necessary

#	Name	Note	Response
1	Yes - No	Disadvantaged/Minority/Women Business Enterprise - D/M/WBE (Required by some participating governmental entities) Vendor certifies that their firm is a D/M/WBE? Vendor must upload proof of certification to the "Response Attachments" D/M/WBE CERTIFICATES section.	Yes
2	Yes - No	Historically Underutilized Business - HUB (Required by some participating governmental entities) Vendor certifies that their firm is a HUB as defined by the State of Texas at https://comptroller.texas.gov/purchasing/vendor/hub/ or in a HUBZone as defined by the US Small Business Administration at https://www.sba.gov/offices/headquarters/ohp Proof of one or both may be submitted. Vendor must upload proof of certification to the "Response Attachments" HUB CERTIFICATES section.	No
3	Yes - No	The Vendor can provide services and/or products to all 50 US States?	Yes
4	States Served:	If answer is NO to question #3, please list which states can be served. (Example: AR, OK, TX)	
5	Company and/or Product Description:	This information will appear on the TIPS website in the company profile section, if awarded a TIPS contract. (Limit 750 characters.)	GNP Energy offers USA made high quality LED lights and retrofits for municipal infrastructure and facilities. we have completed numerous whole city street light retrofits and include our industry best 10 year warranty. we have solutions for all your high wattage systems to reduce consumption by as much as 90% and eliminates maintenance expenses.
6	Primary Contact Name	Primary Contact Name	Mark Fiacable
7	Primary Contact Title	Primary Contact Title	VP Sales and Marketing
8	Primary Contact Email	Primary Contact Email	info@gnpenergy.com
9	Primary Contact Phone	Enter 10 digit phone number. (No dashes or extensions) Example: 8668398477	312-970-1533
10	Primary Contact Fax	Enter 10 digit phone number. (No dashes or extensions) Example: 8668398477	866-286-1588
11	Primary Contact Mobile	Enter 10 digit phone number. (No dashes or extensions) Example: 8668398477	708-269-6451
12	Secondary Contact Name	Secondary Contact Name	Price Sowers
13	Secondary Contact Title	Secondary Contact Title	VP Business Development
14	Secondary Contact Email	Secondary Contact Email	price.sowers@gnpenergy.com

15	Secondary Contact Phone	Enter 10 digit phone number. (No dashes or extensions) Example: 8668398477	630-433-8572
16	Secondary Contact Fax	Enter 10 digit phone number. (No dashes or extensions) Example: 8668398477	866-286-1588
17	Secondary Contact Mobile	Enter 10 digit phone number. (No dashes or extensions) Example: 8668398477	630-433-8572
18	Admin Fee Contact Name	Admin Fee Contact Name. This person is responsible for paying the admin fee to TIPS.	Janet Fiacable
19	Admin Fee Contact Email	Admin Fee Contact Email	info@gnpenergy.com
20	Admin Fee Contact Phone	Enter 10 digit phone number. (No dashes or extensions) Example: 8668398477	708-860-3715
21	Purchase Order Contact Name	Purchase Order Contact Name. This person is responsible for receiving Purchase Orders from TIPS.	Mark Fiacable
22	Purchase Order Contact Email	Purchase Order Contact Email	mark.fiacable@gnpenergy.com
23	Purchase Order Contact Phone	Enter 10 digit phone number. (No dashes or extensions) Example: 8668398477	312-970-1533
24	Company Website	Company Website (Format - www.company.com)	www.gnpenergy.com
25	Federal ID Number:	Federal ID Number also known as the Employer Identification Number. (Format - 12-3456789)	26-1105592
26	Primary Address	Primary Address	17000 Alico Commerce Ct #103
27	Primary Address City	Primary Address City	FT Myers
28	Primary Address State	Primary Address State (2 Digit Abbreviation)	Florida
29	Primary Address Zip	Primary Address Zip	33967
30	Search Words:	Please list search words to be posted in the TIPS database about your company that TIPS website users might search. Words may be product names, manufacturers, or other words associated with the category of award. YOU MAY NOT LIST NON-CATEGORY ITEMS. (Limit 500 words) (Format: product, paper, construction, manufacturer name, etc.)	LED lights, LED fixtures, LED retrofits, LED street lights, LED parking lot lights, LED sports lights, LED high bays
31	Yes - No	Most of our members receive Federal Government grants and they make up a significant portion of their budgets. The members need to know if your company is willing to sell to them when they spend federal budget funds on their purchase. There are attributes that follow that are provisions from the federal regulations in 2 CFR part 200. Your answers will determine if your award will be designated as Federal or Education Department General Administrative Regulations (EDGAR)compliant. Is it your intent to be able to sell to our members regardless of the fund source, whether it be local, state or federal?	Yes
32	Yes - No	Certification of Residency (Required by the State of Texas) The vendor's ultimate parent company or majority owner: (A) has its principal place of business in Texas; OR (B) employs at least 500 persons in Texas?	No

33	Company Residence (City)	Vendor's principal place of business is in the city of?	FT Myers
34	Company Residence (State)	Vendor's principal place of business is in the state of?	Florida
35	Felony Conviction Notice:	(Required by the State of Texas) My firm is, as outlined on PAGE 5 in the Instructions to Bidders document: (Questions 36 - 37) Statutory citation covering notification of criminal history of contractor is found in the Texas Education Code #44.034. Following is an example of a felony conviction notice: State of Texas Legislative Senate Bill No. 1, Section 44.034, Notification of Criminal History, Subsection (a), states "a person or business entity that enters into a contract with a school district or ESC 8/TIPS must give advance notice to the district or ESC 8/TIPS if the person or an owner or operator of the business entity has been convicted of a felony. The notice must include a general description of the conduct resulting in the conviction of a felony." Subsection (b) states "a school district may terminate a contract with a person or business entity if the district determines that the person or business entity failed to give notice as required by Subsection (a) or misrepresented the conduct resulting in the conviction. The district must compensate the person or business entity for services performed before the termination of the contract."	(No Response Required)
36	Yes - No	A publicly held corporation; therefore, this reporting requirement is not applicable?	No
37	Yes - No	Is owned or operated by individual(s) who has/have been convicted of a felony?	No
38	If your firm is owned or operated by the following individual(s) who has/have been convicted of a felony:	Please provide details of the conviction. This is not necessarily a disqualifying factor and the details of the conviction determines the eligibility. Providing false or misleading information about the conviction is illegal.	
39	Pricing Information:	Pricing information section. (Questions 39 - 43)	(No Response Required)
40	Discount Offered	What is the MINIMUM percentage discount off of any item or service you offer to TIPS Members that is in your regular catalog (as defined in the RFP document), website, store or shelf pricing? This is a ceiling on your pricing and not a floor because, in order to be more competitive in the individual circumstance, you may offer a larger discount depending on the items or services purchased and the quantity at time of sale. Must answer with a number between 0% and 100%.	15%
41	TIPS administration fee	By submitting a proposal, I agree that all pricing submitted to TIPS shall include the participation fee, as designated in the solicitation or as otherwise agreed in writing and shall be remitted to TIPS by the Vendor as agreed in the Vendor agreement. I agree that the fee shall not and will not be added by the vendor as a separate line item on a TIPS member invoice, quote, proposal or any other written communications with the TIPS member.	(No Response Required)
42	Yes - No	Vendor agrees to remit to TIPS the required administration fee? TIPS/ESC Region 8 is required by Texas Government Code § 791 to be compensated for its work and thus, failure to agree shall render your response void and it will	Yes

not be considered.

43	Yes - No	Do you offer additional discounts to TIPS members for large order quantities or large scope of work?	Yes
44	Start Time	Average start time after receipt of customer order is ____ working days?	15
45	Years Experience	Company years experience in this category?	10
46	Resellers:	Does the vendor have resellers that it will name under this contract? Resellers are defined as other companies that sell your products under an agreement with you, the awarded vendor of TIPS. EXAMPLE: Walmart is a reseller of Samsung Electronics. If Samsung were a TIPS awarded vendor, then Samsung would list Walmart as a reseller. (If applicable, vendor should download the Reseller/Dealers spreadsheet from the Attachments section, fill out the form and submit the document in the "Response Attachments" RESELLERS section.	No
47	Prices are guaranteed for?	Vendor agrees to honor the pricing discount off regular catalog (as defined in the RFP document), website, store or shelf pricing for the term of the award?	YES
48	Right of Refusal	Does the proposing vendor wish to reserve the right not to perform under the awarded agreement with a TIPS member at vendor's discretion?	Yes
49	NON-COLLUSIVE BIDDING CERTIFICATE	By submission of this bid or proposal, the Bidder certifies that: 1) This bid or proposal has been independently arrived at without collusion with any other Bidder or with any Competitor; 2) This bid or proposal has not been knowingly disclosed and will not be knowingly disclosed, prior to the opening of bids, or proposals for this project, to any other Bidder, Competitor or potential competitor; 3) No attempt has been or will be made to induce any other person, partnership or corporation to submit or not to submit a bid or proposal; 4) The person signing this bid or proposal certifies that he has fully informed himself regarding the accuracy of the statements contained in this certification, and under the penalties being applicable to the Bidder as well as to the person signing in its behalf. Not a negotiable term. Failure to agree will render your proposal non-responsive and it will not be considered.	(No Response Required)

- 50 Texas HB 89- Texas Government code §2270 compliance Texas 2017 House Bill 89 has been signed into law by the governor and as of September 1, 2017 will become law codified as Texas Government Code § 2270 and 808 et seq. YES
- The relevant section addressed by this form reads as follows:
Texas Government Code Sec. 2270.002. PROVISION REQUIRED IN CONTRACT. A governmental entity may not enter into a contract with a company for goods or services unless the contract contains a written verification from the company that it: (1) does not boycott Israel; and (2) will not boycott Israel during the term of the contract.
- I verify by my "YES" response to this attribute that, as a company submitting a proposal to this solicitation, that I am authorized to respond for the company and affirm that the company (1) does not boycott Israel; and (2) will not boycott Israel during the term of this contract, or any contract with the above-named Texas governmental entity in the future. I further affirm that if our company's position on this issue is reversed and this affirmation is no longer valid, that TIPS will be notified in writing by email to TIPS@TIPS-USA.com within one (1) business day and we understand that our company's failure to affirm and comply with the requirements of Texas Government Code 2270 et seq. shall result in a "no award" determination by TIPS and if a contract exists with TIPS, be grounds for immediate contract termination without penalty to TIPS and Education Service Center Region 8.
FAILURE TO RESPOND "YES" WILL RESULT IN NO CONSIDERATION OF YOUR PROPOSAL.
I swear and affirm that the above is true and correct by a "YES" response.
- 51 CONFLICT OF INTEREST QUESTIONNAIRE - FORM CIQ If you have a conflict of interest as described in this form or the Local Government Code Chapter 176, cited therein- you are required to complete and file with TIPS, Richard Powell, 4845 US Highway 271 North, Pittsburg, Texas 75686 No
- You may find the Blank CIQ form on our website at:
Copy and Paste the following link into a new browser or tab:
<https://www.tips-usa.com/assets/documents/docs/CIQ.pdf>
- Do you have any conflicts under this statutory requirement?
- 52 Filing of Form CIQ If yes (above), have you filed a form CIQ as directed here?
- 53 Regulatory Standing I certify to TIPS for the proposal attached that my company is in good standing with all governmental agencies Federal or state that regulate any part of our business operations. If not, please explain in the next attribute question. Yes
- 54 Regulatory Standing Regulatory Standing explanation of no answer on previous question.

55 Antitrust Certification Statements (Tex. Government Code § 2155.005)

By submission of this bid or proposal, the Bidder certifies that: (No Response Required)

I affirm under penalty of perjury of the laws of the State of Texas that:

(1) I am duly authorized to execute this contract on my own behalf or on behalf of the company, corporation, firm, partnership or individual (Company) listed below;

(2) In connection with this bid, neither I nor any representative of the Company has violated any provision of the Texas Free Enterprise and Antitrust Act, Tex. Bus. & Comm. Code Chapter 15;

(3) In connection with this bid, neither I nor any representative of the Company has violated any federal antitrust law;

(4) Neither I nor any representative of the Company has directly or indirectly communicated any of the contents of this bid to a competitor of the Company or any other company, corporation, firm, partnership or individual engaged in the same line of business as the Company.

Instructions for Certification:

1. By agreeing to the Attribute question #56, the vendor and prospective lower tier participant is providing the certification set out herein in accordance with these instructions.
2. The certification in this clause is a material representation of fact upon which reliance was placed when this transaction was entered into. If it is later determined that the prospective lower tier participant knowingly rendered an erroneous certification in addition to other remedies available to the federal government, the department or agency with which this transaction originated may pursue available remedies, including suspension and / or debarment.
3. The prospective lower tier participant shall provide immediate written notice to the person to which this proposal is submitted if at any time the prospective lower tier participant learns that its certification was erroneous when submitted or has become erroneous by reason of changed circumstances.
4. The terms "covered transaction," "debarred," "suspended," "ineligible," "lower tier covered transaction," "participants," "person," "primary covered transaction," "principal," "proposal" and "voluntarily excluded," as used in this clause, have the meanings set out in the Definitions and Coverage sections of rules implementing Executive Order 12549. You may contact the person to which this proposal is submitted for assistance in obtaining a copy of those regulations.
5. The prospective lower tier participant agrees by submitting this form that, should the proposed covered transaction be entered into, it shall not knowingly enter into any lower tier covered transaction with a person who is debarred, suspended, declared ineligible or voluntarily excluded from participation in this covered transaction, unless authorized by the department or agency with which this transaction originated.
6. The prospective lower tier participant further agrees by submitting this form that it will include this clause titled "Certification Regarding Debarment, Suspension, Ineligibility and Voluntary Exclusion-Lower Tier Covered Transaction" without modification in all lower tier covered transactions and in all solicitations for lower tier covered transactions.
7. A participant in a covered transaction may rely upon a certification of a prospective participant in a lower tier covered transaction that it is not debarred, suspended, ineligible or voluntarily excluded from the covered transaction, unless it knows that the certification is erroneous. A participant may decide the method and frequency by which it determines the eligibility of its principals. Each participant may, but is not required to, check the Nonprocurement List.
8. Nothing contained in the foregoing shall be construed to require establishment of a system of records in order to render in good faith the certification required by this clause. The knowledge and information of a participant is not required to exceed that which is normally possessed by a prudent person in the ordinary course of business dealings.
9. Except for transactions authorized under paragraph 5 of these instructions, if a participant in a covered transaction knowingly enters into a lower tier covered transaction with a person who is suspended, debarred, ineligible or voluntarily excluded from participation in this transaction, in addition to other remedies available to the federal government, the department or agency with which this

transaction originated may pursue available remedies, including suspension and / or debarment.

57 Suspension or Debarment Certification

Debarment and Suspension (Executive Orders 12549 and 12689)—A contract award (see 2 CFR 180.220) must not be made to parties listed on the governmentwide exclusions in the System for Award Management (SAM), in accordance with the OMB guidelines at 2 CFR 180 that implement Executive Orders 12549 (3 CFR part 1986 Comp., p. 189) and 12689 (3 CFR part 1989 Comp., p. 235), "Debarment and Suspension." SAM Exclusions contains the names of parties debarred, suspended, or otherwise excluded by agencies, as well as parties declared ineligible under statutory or regulatory authority other than Executive Order 12549.

By submitting this offer and certifying this section, this bidder:
Certifies that no suspension or debarment is in place, which would preclude receiving a federally funded contract as described above.

58 Non-Discrimination Statement and Certification

In accordance with Federal civil rights law, all U.S. Departments, including the U.S. Department of Agriculture (USDA) civil rights regulations and policies, the USDA, its Agencies, offices, and employees, and institutions participating in or administering USDA programs are prohibited from discriminating based on race, color, national origin, religion, sex, gender identity (including gender expression), sexual orientation, disability, age, marital status, family/parental status, income derived from a public assistance program, political beliefs, or reprisal or retaliation for prior civil rights activity, in any program or activity conducted or funded by USDA (not all bases apply to all programs). Remedies and complaint filing deadlines vary by program or incident. Persons with disabilities who require alternative means of communication for program information (e.g., Braille, large print, audiotope, American Sign Language, etc.) should contact the responsible Agency or USDA's TARGET Center at (202) 720-2600 (voice and TTY) or contact USDA through the Federal Relay Service at (800) 877-8339. Additionally, program information may be made available in languages other than English. To file a program discrimination complaint, complete the USDA Program Discrimination Complaint Form, AD-3027, found online at How to File a Program Discrimination Complaint and at any USDA office or write a letter addressed to USDA and provide in the letter all of the information requested in the form. To request a copy of the complaint form, call (866) 632-9992. Submit your completed form or letter to USDA by: (1) mail: U.S. Department of Agriculture, Office of the Assistant Secretary for Civil Rights, 1400 Independence Avenue, SW, Washington, D.C. 20250-9410; (2) fax: (202) 690-7442; or (3) email: program.intake@usda.gov. (Title VI of the Education Amendments of 1972; Section 504 of the Rehabilitation Act of 1973; the Age Discrimination Act of 1975; Title 7 CFR Parts 15, 15a, and 15b; the Americans with Disabilities Act; and FNS Instruction 113-1, Civil Rights Compliance and Enforcement – Nutrition Programs and Activities) All U.S. Departments, including the USDA are equal opportunity provider, employer, and lender.

Not a negotiable term. Failure to agree will render your

proposal non-responsive and it will not be considered. I certify that in the performance of a contract with TIPS or its members, that our company will conform to the foregoing anti-discrimination statement and comply with the cited and all other applicable laws and regulations.

59 2 CFR PART 200 Contract Provisions Explanation

Required Federal contract provisions of Federal Regulations for Contracts for contracts with ESC Region 8 and TIPS Members:

(No Response Required)

The following provisions are required to be in place and agreed if the procurement is funded in any part with federal funds.

The ESC Region 8 and TIPS Members are the subgrantee or Subrecipient by definition. Most of the provisions are located in 2 CFR PART 200 - Appendix II to Part 200—Contract Provisions for Non-Federal Entity Contracts Under Federal Awards at 2 CFR PART 200. Others are included within 2 CFR part 200 et al.

In addition to other provisions required by the Federal agency or non-Federal entity, all contracts made by the non-Federal entity under the Federal award must contain provisions covering the following, as applicable.

60 2 CFR PART 200 Contracts

Contracts for more than the simplified acquisition threshold currently set at \$150,000, which is the inflation adjusted amount determined by the Civilian Agency Acquisition Council and the Defense Acquisition Regulations Council (Councils) as authorized by 41 U.S.C. 1908, must address administrative, contractual, or legal remedies in instances where contractors violate or breach contract terms, and provide for such sanctions and penalties as appropriate. Notice: Pursuant to the above, when federal funds are expended by ESC Region 8 and TIPS Members, ESC Region 8 and TIPS Members reserves all rights and privileges under the applicable laws and regulations with respect to this procurement in the event of breach of contract by either party.
Does vendor agree?

Yes

61 2 CFR PART 200 Termination

Termination for cause and for convenience by the grantee or subgrantee including the manner by which it will be effected and the basis for settlement. (All contracts in excess of \$10,000)
Pursuant to the above, when federal funds are expended by ESC Region 8 and TIPS Members, ESC Region 8 and TIPS Members reserves the right to terminate any agreement in excess of \$10,000 resulting from this procurement process for cause after giving the vendor an appropriate opportunity and up to 30 days, to cure the causal breach of terms and conditions. ESC Region 8 and TIPS Members reserves the right to terminate any agreement in excess of \$10,000 resulting from this procurement process for convenience with 30 days notice in writing to the awarded vendor. The vendor would be compensated for work performed and goods procured as of the termination date if for convenience of the ESC Region 8 and TIPS Members. Any award under this procurement process is not exclusive and the ESC Region 8 and TIPS reserves the right to purchase goods and services from other vendors when it is in the best interest of the ESC Region 8 and TIPS.
Does vendor agree?

Yes

62	2 CFR PART 200 Clean Air Act	<p>Clean Air Act (42 U.S.C. 7401-7671q.) and the Federal Water Pollution Control Act (33 U.S.C. 1251-1387), as amended—Contracts and subgrants of amounts in excess of \$150,000 must contain a provision that requires the non-Federal award to agree to comply with all applicable standards, orders or regulations issued pursuant to the Clean Air Act (42 U.S.C. 7401-7671q) and the Federal Water Pollution Control Act as amended (33 U.S.C. 1251-1387). Violations must be reported to the Federal awarding agency and the Regional Office of the Environmental Protection Agency (EPA).</p> <p>Pursuant to the Clean Air Act, et al above, when federal funds are expended by ESC Region 8 and TIPS Members, ESC Region 8 and TIPS Members requires that the proposer certify that during the term of an award by the ESC Region 8 and TIPS Members resulting from this procurement process the vendor agrees to comply with all of the above regulations, including all of the terms listed and referenced therein.</p> <p>Does vendor agree?</p>	Yes
63	2 CFR PART 200 Byrd Anti-Lobbying Amendment	<p>Byrd Anti-Lobbying Amendment (31 U.S.C. 1352)—Contractors that apply or bid for an award exceeding \$100,000 must file the required certification. Each tier certifies to the tier above that it will not and has not used Federal appropriated funds to pay any person or organization for influencing or attempting to influence an officer or employee of any agency, a member of Congress, officer or employee of Congress, or an employee of a member of Congress in connection with obtaining any Federal contract, grant or any other award covered by 31 U.S.C. 1352. Each tier must also disclose any lobbying with non-Federal funds that takes place in connection with obtaining any Federal award. Such disclosures are forwarded from tier to tier up to the non-Federal award.</p> <p>Pursuant to the above, when federal funds are expended by ESC Region 8 and TIPS Members, ESC Region 8 and TIPS Members requires the proposer certify that during the term and during the life of any contract with ESC Region 8 and TIPS Members resulting from this procurement process the vendor certifies to the terms included or referenced herein.</p> <p>Does vendor agree?</p>	Yes
64	2 CFR PART 200 Federal Rule	<p>Compliance with all applicable standards, orders, or requirements issued under section 306 of the Clean Air Act (42 U.S.C. 1857(h)), section 508 of the Clean Water Act (33 U.S.C. 1368), Executive Order 11738, and Environmental Protection Agency regulations (40 CFR part 15). (Contracts, subcontracts, and subgrants of amounts in excess of \$100,000)</p> <p>Pursuant to the above, when federal funds are expended by ESC Region 8 and TIPS Members, ESC Region 8 and TIPS Members requires the proposer certify that in performance of the contracts, subcontracts, and subgrants of amounts in excess of \$100,000, the vendor will be in compliance with all applicable standards, orders, or requirements issued under section 306 of the Clean Air Act (42 U.S.C. 1857(h)), section 508 of the Clean Water Act (33 U.S.C. 1368), Executive Order 11738, and Environmental Protection Agency regulations (40 CFR part 15).</p> <p>Does vendor certify that it is in compliance with the Clean Air Act?</p>	Yes

65	2 CFR PART 200 Procurement of Recovered Materials	<p>A non-Federal entity that is a state agency or agency of a political subdivision of a state and its contractors must comply with section 6002 of the Solid Waste Disposal Act, as amended by the Resource Conservation and Recovery Act. The requirements of Section 6002 include procuring only items designated in guidelines of the Environmental Protection Agency (EPA) at 40 CFR part 247 that contain the highest percentage of recovered materials practicable, consistent with</p> <p>maintaining a satisfactory level of competition, where the purchase price of the item exceeds \$10,000 or the value of the quantity acquired during the preceding fiscal year exceeded \$10,000; procuring solid waste management services in a manner that maximizes energy and resource recovery; and establishing an affirmative procurement program for procurement of recovered materials identified in the EPA guidelines.</p> <p>Does vendor certify that it is in compliance with the Solid Waste Disposal Act as described above?</p>	Yes
66	Indemnification	<p>The ESC Region 8 and TIPS is a Texas Political Subdivision and a local governmental entity; therefore, is prohibited from</p> <p>indemnifying third parties pursuant to the Texas Constitution (Article 3, Section 52) except as specifically provided by law or as</p> <p>ordered by a court of competent jurisdiction. A provision in a contract to indemnify or hold a party harmless is a promise to pay for</p> <p>any expenses the indemnified party incurs, if a specified event occurs, such as breaching the terms of the contract or negligently</p> <p>performing duties under the contract. Article III, Section 49 of the Texas Constitution states that "no debt shall be created by or on</p> <p>behalf of the State ... " The Attorney General has counseled that a contractually imposed obligation of indemnity creates a "debt" in</p> <p>the constitutional sense. Tex. Att'y Gen. Op. No. MW-475 (1982). Contract clauses which require the System or institutions to</p> <p>indemnify must be deleted or qualified with "to the extent permitted by the Constitution and Laws of the State of Texas." Liquidated</p> <p>damages, attorney's fees, waiver of vendor's liability, and waiver of statutes of limitations clauses should also be deleted or qualified</p> <p>with "to the extent permitted by the Constitution and laws of State of Texas."</p> <p>Not a negotiable term. Failure to agree will render your proposal non-responsive and it will not be considered. Do you agree</p> <p>to these terms?</p>	Yes

67 Remedies	<p>The parties shall be entitled to exercise any right or remedy available to it either at law or in equity, subject to the choice of law, venue and service of process clauses limitations agreed herein. Nothing in this agreement shall commit the TIPS to an arbitration resolution of any disagreement under any circumstances. Any Claim arising out of or related to the Contract, except for those specifically waived under the terms of the Contract, may, after denial of the Board of Directors, be subject to mediation at the request of either party. Any issues not resolved hereunder must be referred to non-binding mediation to be conducted by a mutually agreed upon mediator as a prerequisite to the filing of any lawsuit over such issue(s). The parties shall share the mediator's fee and any associated filing fee equally. Mediation shall be held in Camp or Titus County, Texas. Agreements reached in mediation shall be reduced to writing, and will be subject to the approval by the District's Board of Directors, signed by the Parties if approved by the Board of Directors, and, if signed, shall thereafter be enforceable as provided by the laws of the State of Texas.</p> <p>Do you agree to these terms?</p>	Yes, I Agree
-------------	---	--------------

68 Remedies Explanation of No Answer

69 Choice of Law	<p>This agreement and any addenda or other additions and all contracts or awards resulting from this procurement process, however described, shall be governed by, construed and enforced in accordance with the laws of the State of Texas, regardless of any conflict of laws principles.</p> <p>Not a negotiable term. Failure to agree will render your proposal non-responsive and it will not be considered. Do you agree to these terms?</p>	Yes
------------------	---	-----

70 Jurisdiction and Service of Process	<p>Any Proceeding arising out of or relating to this procurement process or any contract issued by TIPS resulting from or any contemplated transaction shall be brought in a court of competent jurisdiction in Camp County, Texas and each of the parties irrevocably submits to the exclusive jurisdiction of said court in any such proceeding, waives any objection it may now or hereafter have to venue or to convenience of forum, agrees that all claims in respect of the Proceeding shall be heard and determined only in any such court, and agrees not to bring any proceeding arising out of or relating to this procurement process or any contract resulting from or any contemplated transaction in any other court. The parties agree that either or both of them may file a copy of this paragraph with any court as written evidence of the knowing, voluntary and freely bargained for agreement between the parties irrevocably to waive any objections to venue or to convenience of forum. Process in any Proceeding referred to in the first sentence of this Section may be served on any party anywhere in the world. Venue clauses in contracts with TIPS members may be determined by the parties.</p>	Yes
--	--	-----

Not a negotiable term. Failure to agree will render your proposal non-responsive and it will not be considered. Do you agree to these terms?

- 71 Alternative Dispute Resolution Yes, I Agree
Prior to filing of litigation, the parties may select non-binding mediation as a method of conflict resolution for issues arising out of or relating to this procurement process or any contract resulting from or any contemplated transaction. The parties agree that if nonbinding mediation is chosen as a resolution process, the parties must agree to the chosen mediator(s) and that all mediation venue shall be at a location in Camp or Titus, County, Texas agreed by the parties. The parties agree to share equally the cost of the mediation process and venue cost.
Do you agree to these terms?
- 72 Alternative Dispute Resolution Explanation of No Answer
- 73 Infringement(s) Yes, I Agree
The successful vendor will be expected to indemnify and hold harmless the TIPS and its employees, officers, agents, representatives, contractors, assignees and designees from any and all third party claims and judgments involving infringement of patent, copyright, trade secrets, trade or service marks, and any other intellectual or intangible property rights attributed to or claims based on the Vendor's proposal or Vendor's performance of contracts awarded and approved.
Do you agree to these terms?
- 74 Infringement(s) Explanation of No Answer
- 75 Acts or Omissions Yes, I Agree
The successful vendor will be expected to indemnify and hold harmless the TIPS, its officers, employees, agents, representatives, contractors, assignees and designees from and against any and all liability, actions, claims, demands or suits, and all related costs, attorney's fees and expenses arising out of, or resulting from any acts or omissions of the vendor or its agents, employees, subcontractors, or suppliers in the execution or performance of any agreements ultimately made by TIPS and the vendor.
Do you agree to these terms?
- 76 Acts or Omissions Explanation of No Answer
- 77 Contract Governance Yes
Any contract made or entered into by the TIPS is subject to and is to be governed by Section 271.151 et seq, Tex Loc Gov't Code. Otherwise, TIPS does not waive its governmental immunities from suit or liability except to the extent expressly waived by other applicable laws in clear and unambiguous language.

78 Payment Terms and Funding Out Clause

Payment Terms:
TIPS or TIPS members shall not be liable for interest or late payment fees on past due balances at a rate higher than permitted by the laws or regulations of the jurisdiction of the TIPS Member.

Yes

Funding Out Clause:
Vendor agrees to abide by the laws and regulations, including Texas Local Government Code § 271.903, or any statutory or regulatory limitations of the jurisdiction of any TIPS Member which governs contracts entered into by the Vendor and TIPS or a TIPS Member that requires all contracts approved by TIPS or a TIPS Member are subject to the budgeting and appropriation of currently available funds by the entity or its governing body.
See statute(s) for specifics or consult your legal counsel. Not a negotiable term. Failure to agree will render your proposal non-responsive and it will not be considered.
Do you agree to these terms?

79 Insurance and Fingerprint Requirements Information

Insurance
If applicable and your staff will be on TIPS member premises for delivery, training or installation etc. and/or with an automobile, you must carry automobile insurance as required by law. You may be asked to provide proof of insurance.
Fingerprint
It is possible that a vendor may be subject to Chapter 22 of the Texas Education Code. The Texas Education Code, Chapter 22, Section 22.0834. Statutory language may be found at: <http://www.statutes.legis.state.tx.us/>
If the vendor has staff that meet both of these criterion:
(1) will have continuing duties related to the contracted services; and
(2) has or will have direct contact with students
Then you have "covered" employees for purposes of completing the attached form.
TIPS recommends all vendors consult their legal counsel for guidance in compliance with this law. If you have questions on how to comply, see below. If you have questions on compliance with this code section, contact the Texas Department of Public Safety Non-Criminal Justice Unit, Access and Dissemination Bureau, FAST-FACT at NCJU@txdps.state.tx.us and you should send an email identifying you as a contractor to a Texas Independent School District or ESC Region 8 and TIPS. Texas DPS phone number is (512) 424-2474.
See form in the next attribute to complete entitled: Texas Education Code Chapter 22 Contractor Certification for Contractor Employees

(No Response Required)

80 Texas Education Code Chapter 22 Contractor Certification for Contractor Employees

Introduction: Texas Education Code Chapter 22 requires entities that contract with school districts to provide services to obtain criminal history record information regarding covered employees. Contractors must certify to the district that they have complied. Covered employees with disqualifying criminal histories are prohibited from serving at a school district.

Definitions: Covered employees: Employees of a contractor or subcontractor who have or will have continuing duties related to the service to be performed at the District and have or will have direct contact with students. The District will be the final arbiter of what constitutes direct contact with students. Disqualifying criminal history: Any conviction or other criminal history information designated by the District, or one of the following offenses, if at the time of the offense, the victim was under 18 or enrolled in a public school:

(a) a felony offense under Title 5, Texas Penal Code; (b) an offense for which a defendant is required to register as a sex offender under Chapter 62, Texas Code of Criminal Procedure; or (c) an equivalent offense under federal law or the laws of another state.

I certify that:

NONE (Section A) of the employees of Contractor and any subcontractors are covered employees, as defined above. If this box is checked, I further certify that Contractor has taken precautions or imposed conditions to ensure that the employees of Contractor and any subcontractor will not become covered employees. Contractor will maintain these precautions or conditions throughout the time the contracted services are provided.

OR

SOME (Section B) or all of the employees of Contractor and any subcontractor are covered employees. If this box is checked, I further certify that:

(1) Contractor has obtained all required criminal history record information regarding its covered employees. None of the covered employees has a disqualifying criminal history.

(2) If Contractor receives information that a covered employee subsequently has a reported criminal history, Contractor will immediately remove the covered employee from contract duties and notify the District in writing within 3 business days.

(3) Upon request, Contractor will provide the District with the name and any other requested information of covered employees so that the District may obtain criminal history record information on the covered employees.

(4) If the District objects to the assignment of a covered employee on the basis of the covered employee's criminal history record information, Contractor agrees to discontinue using that covered employee to provide services at the District.

Noncompliance or misrepresentation regarding this certification may be grounds for contract termination.

81 Solicitation Deviation/Compliance

Does the vendor agree with the General Conditions Standard Terms and Conditions or Item Specifications listed in this proposal invitation? Yes

82	Solicitation Exceptions/Deviations Explanation	<p>If the bidder intends to deviate from the General Conditions Standard Terms and Conditions or Item Specifications listed in this proposal invitation, all such deviations must be listed on this attribute, with complete and detailed conditions and information included or attached.</p> <p>TIPS will consider any deviations in its proposal award decisions, and TIPS reserves the right to accept or reject any bid based upon any deviations indicated below or in any attachments or inclusions.</p> <p>In the absence of any deviation entry on this attribute, the proposer assures TIPS of their full compliance with the Standard Terms and Conditions, Item Specifications, and all other information contained in this Solicitation.</p>	
83	Agreement Deviation/Compliance	Does the vendor agree with the language in the Vendor Agreement?	Yes
84	Agreement Exceptions/Deviations Explanation	<p>If the proposing Vendor desires to deviate from the Vendor Agreement language, all such deviations must be listed on this attribute, with complete and detailed conditions and information included. TIPS will consider any deviations in its proposal award decisions, and TIPS reserves the right to accept or reject any proposal based upon any deviations indicated below. In the absence of any deviation entry on this attribute, the proposer assures TIPS of their full compliance with the Vendor Agreement.</p>	
85	Texas Business and Commerce Code § 272 Requirements as of 9-1-2017	<p>SB 807 prohibits construction contracts to have provisions requiring the contract to be subject to the laws of another state, to be required to litigate the contract in another state, or to require arbitration in another state. A contract with such provisions is voidable. Under this new statute, a "construction contract" includes contracts, subcontracts, or agreements with (among others) architects, engineers, contractors, construction managers, equipment lessors, or materials suppliers. "Construction contracts" are for the design, construction, alteration, renovation, remodeling, or repair of any building or improvement to real property, or for furnishing materials or equipment for the project. The term also includes moving, demolition, or excavation. BY RESPONDING TO THIS SOLICITATION, AND WHEN APPLICABLE, THE PROPOSER AGREES TO COMPLY WITH THE TEXAS BUSINESS AND COMMERCE CODE § 272 WHEN EXECUTING CONTRACTS WITH TIPS MEMBERS THAT ARE TEXAS GOVERNMENT ENTITIES.</p>	(No Response Required)

Line Items

Response Total: \$0.00

References GNP Energy LED

**** Must have at least 3 References. References must be School, City, County, University, State Agency or Other Government.**

Organization	City	State	Contact Name	Contact Phone	Project Type
City of Wood Dale	Wood Dale	IL	Jeffrey Miermuys	630-766-4900	Street Lights
York Township	york township	IL	John Valle	630-620-2400	building lighting
Judson University	Elgin	IL	Len Nicosia	847-628-2481	exterior lighting, auditoriom
Addison Township	Addison	IL	Dennis Reboletti	630-530-8161	building lighting
Wauconda Library	Wauconda	IL	Tom Kern	847-526-6225	Parking Lot Lights
City of SanAntonio	SanAntonio	TX	Aaron M Stein	210-207-0269	Park road/walkway lights

Certification Regarding Lobbying

Applicable to Grants, Subgrants, Cooperative Agreements, and Contracts Exceeding \$100,000 in Federal Funds.

Submission of this certification is a prerequisite for making or entering into this transaction and is imposed by section 1352, Title 31, U.S. Code. This certification is a material representation of fact upon which reliance was placed when this transaction was made or entered into. Any person who fails to file the required certification shall be subject to a civil penalty of not less than \$10,000 and not more than \$100,000 for each such failure.

The undersigned certifies, to the best of his or her knowledge and belief, that:

(1) No Federal appropriated funds have been paid or will be paid by or on behalf of the undersigned, to any person for influencing or attempting to influence an officer or employee of any agency, a Member of Congress, an officer or employee of congress, or an employee of a Member of Congress in connection with the awarding of a Federal contract, the making of a Federal grant, the making of a Federal loan, the entering into a cooperative agreement, and the extension, continuation, renewal, amendment, or modification of a Federal contract, grant, loan, or cooperative agreement.

(2) If any funds other than Federal appropriated funds have been paid or will be paid to any person for influencing or attempting to influence an officer or employee of any agency, a Member of Congress, an officer or employee of congress, or an employee of a Member of Congress in connection with this Federal grant or cooperative agreement, the undersigned shall complete and submit Standard Form-LLL, "disclosure Form to Report Lobbying," in accordance with its instructions.

(3) The undersigned shall require that the language of this certification be included in the award documents for all covered subawards exceeding \$100,000 in Federal funds at all appropriate tiers and that all subrecipients shall certify and disclose accordingly.

GNP Energy

17000 Alico commerce ct 103 FT Myers FL 33967

Name/Address of Organization

Mark Fiacable VP Sales

Name/Title of Submitting Official

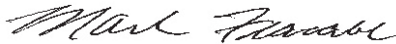

Signature

3-9-218

Date

FELONY CONVICTION NOTICE

FOR RESPONSE TO TIPS SOLICITATION

Statutory citation covering notification of criminal history of contractor is found in the Texas Education Code #44.034. Following is an example of a felony conviction notice:

State of Texas Legislative Senate Bill No. 1, Section 44.034, Notification of Criminal History, Subsection (a), states “a person or business entity that enters into a contract with a school district must give advance notice to the district if the person or an owner or operator of the business entity has been convicted of a felony. The notice must include a general description of the conduct resulting in the conviction of a felony.” Subsection (b) states “a school district may terminate a contract with a person or business entity if the district determines that the person or business entity failed to give notice as required by Subsection (a) or misrepresented the conduct resulting in the conviction. The district must compensate the person or business entity for services performed before the termination of the contract.”

THIS NOTICE IS NOT REQUIRED OF A PUBLICLY-HELD CORPORATION

Complete only one of the three below: A or B or C.

I, the undersigned agent for the firm named below, certify that the information concerning notification of felony convictions has been reviewed by me and the following information furnished is true to the best of my knowledge.

Official: GNP Energy LED
Print Authorized Company Official’s Name

A. My firm is a publicly held corporation; therefore, this reporting requirement is not applicable.

Signature of Authorized Company Official: _____

OR

B. My firm is not owned nor operated by anyone who has been convicted of a felony:

Signature of Authorized Company Official: Mark Furrer

OR

C. My firm is owned or operated by the following individual(s) who has/have been convicted of a felony:

Name of Felon(s): _____

Details of Conviction(s): _____

You may attach another sheet

Signature of Authorized Company Official: _____

CERTIFICATION BY CORPORATE OFFERER

IF OFFERER IS A CORPORATION,

THE FOLLOWING CERTIFICATE SHOULD BE EXECUTED AND INCLUDED AS PART OF PROPOSAL FORM/PROPOSAL FORM.

OFFERER: Great Northern Processing Corp.
(Name of Corporation)

I, Mark Fiacable certify that I am the Secretary of the Corporation
(Name of Corporate Secretary)

named as OFFERER herein above; that

Mark Fiacable
(Name of person who completed proposal document)

who signed the foregoing proposal on behalf of the corporation offerer is the authorized person that is acting as

VP Sales and Marketing
(Title/Position of person signing proposal/offer document within the corporation)

of the said Corporation; that said proposal/offer was duly signed for and in behalf of said corporation by authority of its governing body, and is within the scope of its corporate powers.

CORPORATE SEAL if available

Mark Fiacable
SIGNATURE

3-9-2017
DATE

Federal Requirements for Procurement and Contracting with small and minority businesses, women's business enterprises, and labor surplus area firms.

The Education Service Center Region 8 and TIPS Members anticipate possibly using federal funds for procurement under this potential award and is required to obtain the following compliance assurance.

1. Will you be subcontracting any of your work under this award if you are successful? (Circle one)

YES or NO

2. If yes, do you agree to comply with the following federal requirements? (Circle one)

YES or NO

2 CFR §200.321 Contracting with small and minority businesses, women's business enterprises, and labor surplus area firms.

(a) The non-Federal entity must take all necessary affirmative steps to assure that minority businesses, women's business enterprises, and labor surplus area firms are used when possible.

(b) Affirmative steps must include:

- (1) Placing qualified small and minority businesses and women's business enterprises on solicitation lists;
- (2) Assuring that small and minority businesses, and women's business enterprises are solicited whenever they are potential sources;
- (3) Dividing total requirements, when economically feasible, into smaller tasks or quantities to permit maximum participation by small and minority businesses, and women's business enterprises;
- (4) Establishing delivery schedules, where the requirement permits, which encourage participation by small and minority businesses, and women's business enterprises;
- (5) Using the services and assistance, as appropriate, of such organizations as the Small Business Administration and the Minority Business Development Agency of the Department of Commerce ; and
- (6) Requiring the prime contractor, if subcontracts are to be let, to take the affirmative steps listed in paragraphs (1) through (5) of this section.

Company Name _____

Print name of authorized representative Mark Fiacable

Signature of authorized representative *Mark Fiacable*

Date _____

Texas Government Code 2270 Verification Form

Texas 2017 House Bill 89 has been signed into law by the governor and as of September 1, 2017 will become law codified as Texas Government Code § 2270 and 808 et seq.

The relevant section addressed by this form reads as follows:

Texas Government Code Sec. 2270.002. PROVISION REQUIRED IN CONTRACT. A governmental entity may not enter into a contract with a company for goods or services unless the contract contains a written verification from the company that it: (1) does not boycott Israel; and (2) will not boycott Israel during the term of the contract.

I, Mark Fiacable as an authorized representative of

GNP Energy, a contractor/vendor
Insert Name of Company

engaged by

ESC Region 8/The Interlocal Purchasing System (TIPS)
4845 Highway 271 North
Pittsburg, TX, 75686

verify by this writing that the above-named company affirms that it (1) does not boycott Israel; and (2) will not boycott Israel during the term of this contract, or any contract with the above-named Texas governmental entity in the future. I further affirm that if our company's position on this issue is reversed and this affirmation is no longer valid, that the above-named Texas governmental entity will be notified in writing within one (1) business day and we understand that our company's failure to affirm and comply with the requirements of Texas Government Code 2270 et seq. shall be grounds for immediate contract termination without penalty to the above-named Texas governmental entity.

AND

our company is not listed on and we do not do business with companies that are on the the Texas Comptroller of Public Accounts list of Designated Foreign Terrorists Organizations per Texas Gov't Code 2270.0153 found at <https://comptroller.texas.gov/purchasing/docs/foreign-terrorist.pdf>

I swear and affirm that the above is true and correct.

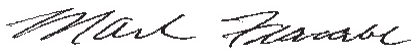

Signature of Named Authorized Company Representative

3-9-2018

Date

**Required Federal contract provisions of Federal Regulations for Construction Contracts
for contracts with TIPS OR TIPS MEMBERS**

The following provisions are required to be in place and agreed if the procurement is funded in any part with federal funds.

The TIPS OR TIPS MEMBERS is the subgrantee or Subrecipient by definition. The Rules are located in 2 CFR PART 200 - Appendix II to Part 200—Contract Provisions for Non-Federal Entity Contracts Under Federal Awards at 2 CFR PART 200

In addition to other provisions required by the Federal agency or non-Federal entity, all contracts made by the non-Federal entity under the Federal award must contain provisions covering the following, as applicable.

(D) Davis-Bacon Act, as amended (40 U.S.C. 3141-3148). When required by Federal program legislation, all prime construction contracts in excess of \$2,000 awarded by non-Federal entities must include a provision for compliance with the Davis-Bacon Act (40 U.S.C. 3141-3144, and 3146-3148) as supplemented by Department of Labor regulations (29 CFR Part 5, “Labor Standards Provisions Applicable to Contracts Covering Federally Financed and Assisted Construction”). In accordance with the statute, contractors must be required to pay wages to laborers and mechanics at a rate not less than the prevailing wages specified in a wage determination made by the Secretary of Labor. In addition, contractors must be required to pay wages not less than once a week. The non-Federal entity must place a copy of the current prevailing wage determination issued by the Department of Labor in each solicitation. The decision to award a contract or subcontract must be conditioned upon the acceptance of the wage determination. The non-Federal entity must report all suspected or reported violations to the Federal awarding agency. The contracts must also include a provision for compliance with the Copeland “Anti-Kickback” Act (40 U.S.C. 3145), as supplemented by Department of Labor regulations (29 CFR Part 3, “Contractors and Subcontractors on Public Building or Public Work Financed in Whole or in Part by Loans or Grants from the United States”). The Act provides that each contractor or subrecipient must be prohibited from inducing, by any means, any person employed in the construction, completion, or repair of public work, to give up any part of the compensation to which he or she is otherwise entitled. The non-Federal entity must report all suspected or reported violations to the Federal awarding agency.

Pursuant to Federal Rule (D) above, when federal funds are expended by TIPS OR TIPS MEMBERS, during the term of an award for all contracts and subgrants for construction or repair, when Federal Funds are expended, by the TIPS OR TIPS MEMBERS resulting for this procurement process the vendor will be in compliance with all provisions listed or referenced therein.

Does vendor agree? YES MF Initial of Authorized Company Official

(E) Contract Work Hours and Safety Standards Act (40 U.S.C. 3701-3708). Where applicable, all contracts awarded by the non-Federal entity in excess of \$100,000 that involve the employment of mechanics or laborers must include a provision for compliance with 40 U.S.C. 3702 and 3704, as supplemented by Department of Labor regulations (29 CFR Part 5). Under 40 U.S.C. 3702 of the Act, each contractor must be

required to compute the wages of every mechanic and laborer on the basis of a standard work week of 40 hours. Work in excess of the standard work week is permissible provided that the worker is compensated at a rate of not less than one and a half times the basic rate of pay for all hours worked in excess of 40 hours in the work week. The requirements of 40 U.S.C. 3704 are applicable to construction work and provide that no laborer or mechanic must be required to work in surroundings or under working conditions which are unsanitary, hazardous or dangerous. These requirements do not apply to the purchases of supplies or materials or articles ordinarily available on the open market, or contracts for transportation or transmission of intelligence.

Pursuant to Federal Rule above, when federal funds are expended by TIPS or TIPS Members, the proposer certifies that during the term of an award by the TIPS OR TIPS MEMBERS resulting from this procurement process for construction contracts awarded by grantees and subgrantees the proposer agrees to be in compliance with all requirements listed or referenced therein.

Does vendor agree? YES MF Initial of Authorized Company Official

Company Name GNP Energy

Print name of authorized representative Mark Fiacable

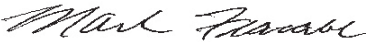
Signature of authorized representative 

Date 3-9-2018

FAILURE TO PROPERLY COMPLETE THIS FORM AND SUBMIT WITH YOUR RESPONSE MAY RESULT IN A WAIVER OF YOUR RIGHTS UNDER THE LAW TO MAINTAIN CONFIDENTIALITY TREATMENT OF SUBMITTED MATERIALS.

CONFIDENTIAL INFORMATION SUBMITTED IN RESPONSE TO COMPETITIVE PROCUREMENT REQUESTS OF EDUCATION SERVICE CENTER REGION 8 AND TIPS IS GOVERNED BY TEXAS GOVERNMENT CODE, CHAPTER 552

If you consider any portion of your proposal to be confidential information and not subject to public disclosure pursuant to Chapter 552 Tex Gov't Code or other law(s), **you must make a copy of all claimed confidential materials within your proposal and put this COMPLETED form as a cover sheet to said materials then scan, name "CONFIDENTIAL" and upload with your proposal submission.** (You must include the confidential information in the submitted proposal as well, the copy uploaded is to indicate which material in your proposal, if any, you deem confidential in the event the District receives a Public Information Request.) Education Service Center Region 8 and TIPS will follow procedures of controlling statute(s) regarding any claim of confidentiality and shall not be liable for any release of information required by law. Pricing of solicited product or service may be deemed as public information under Chapter 552 Tex Gov't Code. The Office of Texas Attorney General shall make the final determination whether the information held by Education Service Center Region 8 and TIPS is confidential and exempt from public disclosure.

If you claim that parts of your proposal are confidential, complete the top section below.

I DO NOT desire to expressly waive any claim of confidentiality as to any and all information contained within our response to the competitive procurement process (e.g. RFP, CSP, Bid, RFQ, etc.) by completing the following and submitting this sheet with our response to Education Service Center Region 8 and TIPS. The attached contains material from our proposal that I classify and deem confidential under Texas Gov't Code Sec. 552 or other law(s) and I invoke my statutory rights to confidential treatment of the enclosed materials.

Name of company claiming confidential status of material

Printed Name and Title of authorized company officer claiming confidential status of material

City State ZIP Phone Address

ATTACHED ARE COPIES OF _____ PAGES OF CONFIDENTIAL MATERIAL FROM OUR PROPOSAL

Signature _____ Date _____

If you do not claim any of your proposal to be confidential, complete the section below only.

Express Waiver: I desire to expressly waive any claim of confidentiality as to any and all information contained within our response to the competitive procurement process (e.g. RFP, CSP, Bid, RFQ, etc.) by completing the following and submitting this sheet with our response to Education Service Center Region 8 and TIPS.

GNP Energy

Name of company expressly waiving confidential status of material

Mark Fiacable VP Sales

Printed Name and Title of authorized company officer expressly waiving confidential status of material

FT Myers FL 33967 312-970-1533

City State ZIP Phone Address

Signature *Mark Fiacable* Date 3-9-2018



TIPS Product Data/Warranty / LIGHTING 03-2015 Renewable Energy Solutions

Innovation:

- [Describe how the technology demonstrates innovation beyond products currently in use.](#)

Through our strategic partnerships GNP Energy proudly markets USA Manufactured sophisticated microprocessor controlled LED products. We provide "off the shelf" UL listed LED field Retrofit Kits (without the added expense of changing the whole fixture) and also new LED Fixtures with 100,000 hour rating or more (15 to 30 years) almost twice the hours of most competitors. We back your investment with our industry best 10 Year Warranty!

Our patent pending Retrofit Kits convert existing HID and Fluorescent light fixtures into ultra long lasting maintenance free, energy efficient LED lighting retrofits. They typically *Reduce energy consumption 70%-90%* for Commercial, Industrial and Municipal lighting applications, which can save thousands monthly on electric and maintenance costs. With an average *ROI of only 24 months and our available Free Retrofit using GNP Energy LED Green Savings Purchase Program*, we also secure your investment with our *Green Savings Performance Guarantee* we make your LED lighting technology switch secure and affordable. No matter which type of fixture: high bays, cobra heads, wall packs, ceilings, parking lots, even high mast and sports lights, we can retrofit 98% of existing fixtures into new high efficiency long lasting LED. From 50 watt to 175W with our GNPSOL2700M minis, and 200W-1500W with our GNPSOL5400 and the ease of only 2 products that replace dozens of different wattage with the flip of a switch on our DLC listed units. In addition, your lighting maintenance cost will be virtually eliminated for the next 10-20 years. We also have full lines of linear LED tubes and bulbs of every type to take care of all your lighting needs; we can retrofit your facility inside out. We will perform a lighting energy audit which will clearly show how much you can save, even applying the numerous rebate incentives and tax credits available for your project, which makes now the time to move forward and start enjoying your new energy saving future.

For our municipal clients, cities, counties, schools, library and park districts, even airports make sure to check out our easy no bid system with our TIPS municipal purchasing COOP contract. You can enjoy the price benefits of large nationwide buying power, and be assured of best pricing. You can issue a PO. while meeting all your bidding requirements saving you time, money, frustration.

Many of our clients benefit from a little hand holding when considering embracing this new technology shift. There are a lot of numbers thrown around that are difficult to put into context... sort of like HDTV a few years ago... we decided to address the primary concerns from the very start, with our patent-pending thermal management and retrofit design backed by our 10 year warranty. GNP Energy has been in the Green Technology business for over 20 years, and we now license our commercial Waste Oil to Diesel Conversion technologies in several countries. Our LED lighting products are manufactured here in the US, providing our clients access to the Buy American Recovery Reinvestment Act (ARRA) funds to substantially assist in reducing the initial investment.

Manufacturers of high-brightness LED lamps and fixtures make wild claims as to their product's life. How can you determine if the product you are buying will last the 15-20 year claims?

LED life is measured in lumen depreciation. This is the percentage of light output degradation from the initial light output. The industry standard is determined by the Illumination Engineering Society of North America. Look for LM-80 specifics for determining lumen depreciation. When researching the different LED vendors and their datasheets, look for proper heat sink and thermal management of silicon junction temperature to discover the lifetime of the LED. Look for lifetime versus junction temperature graphs in LED vendor datasheets that show lumen depreciation. If they do not provide these data sheets and charts, or if they do and the temperatures are 80C, stay away.

The #1 enemy of electronics is heat. Heat degrades the components over time. Our LED head is engineered to dissipate heat in two ways. First, through the 7-layer copper heat-sink, heat is removed from the LED board and



channeled away. *The cooler the LED's operate, the longer they last.* For example, a LED chip operating at 40C like ours will last 100,000 hours, while the same chip operating at 80C will only last 50,000 hours. It is typically impossible to get the LED's to operate at 40c or lower without some secondary cooling system, such as a fan. Our LED system uses a primary heat sink with a secondary *MagLev™* cooling fan, enhancing thermal management. This is the most effective way to remove the heat from the LED system.

The LED power supply or driver design is the other factor that determines lifetime. Find out how the current is being delivered to the LED. Most companies use either a constant voltage or constant current driver.

The driver being used can give you insight to how well they understand LED lighting. A company that designs a LED lighting system using constant current driver incorporates a daisy chain system where LED's are lined up in series. This type of design typically causes the forward voltage and current to vary greatly from the first LED down the line to the last. Over time the first LED in the chain will get higher voltage and current causing it to operate hotter and thereby causing color shifting and premature failure.

Companies that *incorporate constant voltage drivers* in their systems, they typically have a greater understanding of LED technology. Our LED products use constant voltage drivers to deliver the voltage to the PCB where the LED chips are mounted. From the board, the voltage and current are distributed to each LED to guarantee that exact current and voltage is provided with little fluctuation.

Safety features: *Ask your LED lighting supplier how they protect their lighting array.* When spending a lot of money to get a system designed to last 20 plus years, this is a good question to ask. *Make sure they have under voltage protection, over voltage protection, and overheating protection.* These systems insure your LED lighting system will not be compromised. All LED systems are not created equally which is why our lights last up to 80% longer than other LED systems.

Description of how TIPS will benefit from the technology:

- Summarize and/or quantify key benefits from the technology
- Clearly outline assumptions and methodology associated with quantified results
- Describe how the technology would advance sustainability goals and targets
- Include relative magnitude of potential contributions to meeting targeted reductions in energy and GHG emissions.

On Board Microprocessor

GNP Energy's on board microprocessor is a simple solution for flexible and intelligent High Brightness LED control. Whether driving single or multiple strings of LED's, remote interface or monitoring- you can be assured of optimal LED control over wide ranges of operating temperatures and environments.

LED Smart Driver Design Our LED Smart Driver Design is a microcontroller based system utilizing software refined over years of lab and field testing. From this simple single LED string controller we have advanced to a multiple LED string controller with interface and remote monitoring capabilities.

How long is 100,000 hours?

Based on how long a fixture is illuminated per day, here's what 100,000 works out to:



Hours of Operation: 100,000 hours is:
24 hours a day 11.4 years
18 hours per day 14.8 years
12 hours per day 22.8 years
8 hours per day 34.2 years

LEDs in parallel are notoriously poor at sharing current. Small mismatches in forward voltage and dynamic resistance can result in large imbalances in current from string to string. As LED slug temperature increases the imbalances increase. The difference in light output from the hottest string may not be noticeable but the lifetime and lumen maintenance decreases.

Our LED Smart Driver provides current regulation for each individual string of LED's using buck mode PWM control with high side current sense. Current accuracy over the LED operating temperature range is +/- 3%. Modular design enables scalability of the number of LED strings. Isolation of the high current switching from the microcontroller eliminates the feedback in and around the microcontroller package. This feedback causes poor current regulation and inconsistent performance in integrated LED Driver IC solutions. Compact design of the driver combined with advanced thermal management technology allows the driver and LED's to share the same PCB.

LED SMART DRIVER SOFTWARE FEATURES:

- Multiple temperature control values. Over temperature protection, shut down at critical temperature and resume operation temperature.
- Under voltage lockout for power off or brownout.
- Soft start.
- User selectable current.
- Operation time/date control
- Fan operation
- Dimming
- Daylight Harvesting
- Occupancy sensing

LED SMART DRIVER INTERFACE:

- 0-10 V Dimming
- DALI
- RS-232
- USB
- Ethernet
- Wireless

LED SMART DRIVER REMOTE MONITORING:

Remote monitoring of the LED Smart Driver can be achieved using any of the bidirectional interface methods listed above. System health, performance and operational data can be sent to a remote base.

Our Smart-Driver Technology equips us with drivers that individually measure over-current, under-current, over-voltage, under-voltage, the operating temperature, and the individual LED chip color, and keeping all chips operating with the same colored light from Day 1. Our programming utilizes a Safety Mode that shuts down half the chips to both alert us to a problem as well as protect the circuitry. How many gas stations, parking garages, and street lights do you drive past that don't have matching bulbs? This is evidence that the lights and the components are degrading at different rates. Our Solstice Units will never let this happen, it's in their programming and engineering.



The GNP LED light is programmed with a 3-stage Soft Start start-up system whereby the current is fed and monitored in 3 easy levels to protect the chips, modify color and extend the life of the components. Additionally, the LED chips are all wired in parallel design where they all receive equal electrical current at same time. Other LED lights on the market place their chips in series where the first LED chip of the Daisy-chain is hit by all the current every night.

Application and Maturity of the Technology:

- Described where/how this technology is currently in use, how long it have been in use and the documented results

GNP LED technology is truly an AMAZING piece of engineering, invented by an American, made entirely in the USA, with American engineered components, and assembled by Americans. Originally developed in 2004 due to the lack of suitable LED driver components, the first product was a single six LED string current controller. Over 10,000 units were sold and are still operating today. It is UL approved for field retrofit of existing fixtures and DLC listed for rebates, GNPSOL5400 and GNP2700M. We now have numerous different applications in place including one of the first whole city street light retrofits in the country. Also the Indianapolis airport is beginning change over in the terminal can lights, reducing wattage from 175W down to 28W, and parking lots from 400W to 98W. Universities including DePaul U. and Judson University have done large scale roll outs along with other municipal and commercial projects.

This light mounts directly into your existing light fixture and utilizes your facility's wiring. We can replace your existing Sodium High Pressure, Metal Halide, or Mercury Vapor light with GNP LED and *reduce your lighting consumption by 70-90%*. The GNP5400 and 2700M units carries a *100,000+ hour life* with independent testing proving a 200,000 hour life span is possible. GNP Energy back these units with an industry leading 10 year warranty.

If your facility has HID lighting, we have a product that is right for the retrofit. The GNP2700M unit replaces 50W-175W light bulbs, where the GNP5400 unit replaces 70-1500W. In fact, we have a selector switch on-board each of our lights that allows us to select the amount of light we want to produce. We can utilize multiple light engines to increase the light output to match up to 1,500 watts!

For example: Your parking lot is lit with 400W metal halide bulbs, we will replace these with the GNPSOL5400 LED. We light the parking lot with you there, the selector switch set on 95W, (true lumen for lumen retrofit). You say to us, "WOW, how can I save more?" We go up the pole and select the switch from 95W to 80W. This process could then lead down to 70W! "Not enough light there..." you say, "Can you put it back bright?" In about 5 minutes, we have proven equal lighting and then saved you much more than expected.

Risks

- Provide information that demonstrates that the technology or practice is fundamentally sound from a technical perspective
- Provide studies by independent researchers documenting its performance, if available
- Describe any potential risks associated with the field implementation of installation of the technology or practice and provide a plan for risk management

There is no inherent risk with switching to energy efficient lighting, as the light replication and energy savings along with longevity are readily documented. The true risks are financial, as the price someday may decrease; on the other hand currently very large energy rebate dollars are available which could pay for up to 50% of the capital cost, these cash back rebates may not be available after this year as funds are limited. Also delay in implementation will actually cost more by waiting, than could ever be saved by possible future price decreases. The products will pay for themselves in around 2 years and continue to save for over 20 years. You can begin saving today and actually increase cash flow with an immediate ROI and enjoy all the first year savings and rebate monies for 1 year before ever costing you one dime, the true risk is to your bottom line by delaying implementation.



Description of the Lighting Technology:



The GNP2700M LED Module is a flexible and compact point source that will change the way fixtures are designed. Small footprint, easy assembly, and fewer parts will provide both the fixture manufacturer and end-user with lower cost, weight and size. Superior active cooling coupled with proprietary thermal management design ensures the GNP2700M LED Module maintains efficiency at high temperatures, color consistency and low light degradation through its rated life of 100,000 hours. The GNP2700M LED Module allows for a smaller, more flexible fixture design, a footprint that reduces pole and installation cost as well as lower wind loading when used on poles. Only 4.5" in diameter delivering 5850 Lumens brilliantly equipped with 21 Philips Rebel LED's in 3 clusters. Optional hardware includes 5 optic packages to meet any FC/distribution requirement: 25, 50, 75, 120, 360 degrees. Approximately the same size as a par 38 lamp, designers now have the brightness to replace high wattage HID lamps in a small footprint. Available as both retrofit and new architectural track and combo recessed fixtures.

New Lumen maintenance regulator circuit

LED chips slightly degrade over time. The GNP2700M LED Module has a sophisticated regulator circuit which maintains lumen output over the life of the lamp. Proprietary software includes a special current loop technology to prevent load variation degradation. As the degradation occurs it adjusts the current to compensate. This means no light level reduction for 60,000hrs +!

Switches and Onboard Programs

The GNP2700M LED Module is preloaded with helpful programs designed to allow the customer to optimize each application with the flick of a switch.

STANDARD

The default setting unit is on all the time

561 energy saver program (sav)

When selected, this program allows the customer to operate outdoor lamps at 100% output for the first 5 hours of operation, dimming 50% for 6 late evening hours, than ramping back up to 100% output for the last hour before dawn. This useful program saves 3 hours of operation per night over 1100 hours per year!

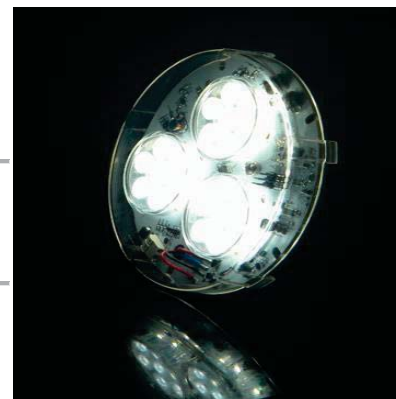

Dimm Sink (default)

This selection becomes handy when using a motion sensor or dimming switch. Sink means that you are using a dimming ballast or controller that provides the 10 v power and the control device adjusts the voltage for your needs. Most control devices are sinking so if you do not know default to this switch setting.



Dimm Source This is selected when the control device is providing the 0-10v power. Theatrical lighting and some large dimming panels provide the 0-10v power.

Wattage selection:

Your 2700M LED Module can be set to 4 output wattages. Depending on the application, you may not need full output and therefore can adjust down to the setting you want.

Approximate wattages:

100%- 58w equivalent to 175w Metal Halide

75%- 48w equivalent to 150w Metal Halide

50%- 38w equivalent to 125w Metal Halide

25%-28w equivalent to 100w Metal Halide

To further increase life of all components including the driver, we have programmed a gradual soft start up in MS (milliseconds). This technology provides excellent lumen maintenance and long lifetime to make frequent re-lamping a thing of the past – a promise that is backed up by a GNP Energy LED TEN (10)-year limited warranty. The lamp and driver have been developed and tested in combination with each other, including key enhancements like thermal protection for the module. The module has been successfully implemented using LM-80 guidelines. As a result, they provide a great lumen output and light distribution, while efficacy upgrades can be implemented when available.

Benefits

- New Lumen Maintenance Circuit
- Increased efficacies
- Color consistency increased
- Dimming options include 0-10V, Wireless
- Rated Life 100,000Hrs
- High Lumen Output
- Substantial energy savings
- Enables Intelligent controls and networking
- Small Footprint-4.50"



Applications

- Offices (areas such as hallways, receptions, boardrooms, etc.)
- Hotel lobbies and receptions areas, Airport Terminals
- Retail high-end shops
- Commercial/Industrial Interior Space (warehouse, parking garage)
- Commercial/Industrial Exterior Space (parking lots, streets, roadways)

Additional protection



- 24V Line Voltage Variation regulation
- Under Voltage Protection 21v Minimum
- Over Voltage Protection 30V shut off
- Reset 27V or lower
- Over Temp-thermistor-90C shut off
- Below 85C turns back on

END USER MODULE ADAPTERS & Fixtures

The GNP2700M LED Module is available with optional adapters to facilitate simple retrofit of existing fixture housings. It is available in new Track and Recessed fixtures.



- [© Fully Compliant with ARRA Buy American requirements. Made in the U.S.A. with U.S. and imported components.](#)

Yoke Application



Plate Application



GNPSOL5400 & GNP2700M

Application

GNP Energy's LED units are designed to retrofit into almost any HID fixture using custom fabricated brackets and plates for easy plug and play installation. We can articulate our units and offer a wide array of innovative optics to deliver the light precisely where it's needed. Dark Sky Compliant, Four way switchable power options on board, This unit also comes with an Energy Saver program that is accessed via a switch on the board.

Some of our KEY features: GNPSOL5400

- Multiple temperature control values. Over temperature protection, shut



down at critical temperature and resume operation temperature.

- Under voltage lockout for power off or brownout
- Soft start
- 0 – 10 V Dimming compatible
- Under voltage lockout for power off or brownout.
- 0-10v Input Port.
- Occupancy sensing Current accuracy over the LED operating Temperature range +/- 3%.

4 wattage selections by switch:

GNP SOL5400 – 70W, 80W, 90W, 130W

Driver

50/60Hz ballast. Input voltage 120-277V135w Step Down Ballast from input voltage to 24V to Solstice Unit.480V / 135W Ballast also available.

*24V operation without driver.

Input Voltages:

120vAC, 220 – 277vAC, 24vDC

480vAC, 24vDC

For Solar Powered Application – No Driver is required

MagLev® Fan Technology

By using magnetic levitation force, these fans feature zero friction with no contact between shaft and bearing. 100,000 hours rated operating life, providing an exceptionally cool running LED unit -42° Celsius at ambient temperatures.

Operating Temperature Range:

-40 to +85 degrees Celsius

Lensing

Multiple lensing options available for maximum light distribution, if needed.

Distribution Pattern

Multiple mounting positions for a broad range of narrow to spread symmetrical lighting distribution choices.

- Laboratory-validated performance data using standard testing protocols
- Record of meetings all applicable codes and standards

Our credibility is supported by performance data and testing through CUL independent laboratory testing. Our retrofit kits are ARRA compliant and LM79/LM80 tested, UL listed, Rohs, ETL, DLC listed

- *Product Spec sheets attached

GNP Energy LED WARRANTY



Manufacture warrants the LED Light engine for a period of 10 years of purchase date from the manufacture. Supplied with the LED is a driver which is warranted by the driver manufacturer for 5 years. GNP Energy will determine any unit defective if one or more of the following occurs.

- Any individual LED or bank of LEDs do not light,
- This warranty is conditioned upon proper storage, installation, use and maintenance. Led chips have a sealed lens, broken top lenses on led chip, scuffs or other apparent signs of mishandling may void warranty. Manufacture may repair the damage at an additional cost. Estimate will be given prior to repair.

This warranty is not applicable to any LED Unit which is not installed and operated in accordance with the current edition of The National Electric Code (NEC), the Standards for Safety of Underwriters' Laboratory, Inc. (UL), the Standards for the American National Standards Institute (ANSI), and with GNP Energy instructions and guidelines.

This warranty is not applicable to any product subjected to abnormal stresses and operating conditions. GNP Energy shall correct any defects, at Manufacture's option, by either repairing any defective part or parts or by replacing any defective part or parts or by making available a new replacement LED unit. The conditions of any tests concerning any Solstice Product which is claimed to have not performed to this warranty shall be mutually agreed upon in writing and GNP Energy shall be notified of, and may be represented at any such tests. This express limited warranty is extended by Manufacture only to the original or first end-user purchaser. Warranty claims are to be made in accordance with GNP Energy's published Warranty Service Program.

Testing Methodology. Describe the following:

- Specific technical or performance objectives to be validated through the testing of the technology in existing applications
- Recommended methods for measuring and assessing the performance and expected operational costs of the technology
- Overview of how a baseline will be quantified against which to measure the technology

Considering that this technology, if selected, would be tested in an operational environment to assess its costs and benefits.

Proposed Testing: GNP Energy LED retrofits for several types of current fixtures in Kane county including parking lot, parking garage ceiling and wall packs, interior and exterior can lights, Linear tubes, from 2-4 fixtures of each type. Pre and post install wattage and light measurements would be taken to verify energy savings and proper light levels. Lights may stay in place for up to 2 months for review. At the end of trial demo retrofits may be purchased or removed and returned to GNP Energy. We will also offer Kane County a special municipal project funding with no payment for 1 year and then 3 years at 0% interest, no money out of pocket, project pays for itself out of savings achieved and increases your cash flow. Once payments are done in 36 months you keep all the savings and own the lights.

Cost Savings

GNP Energy

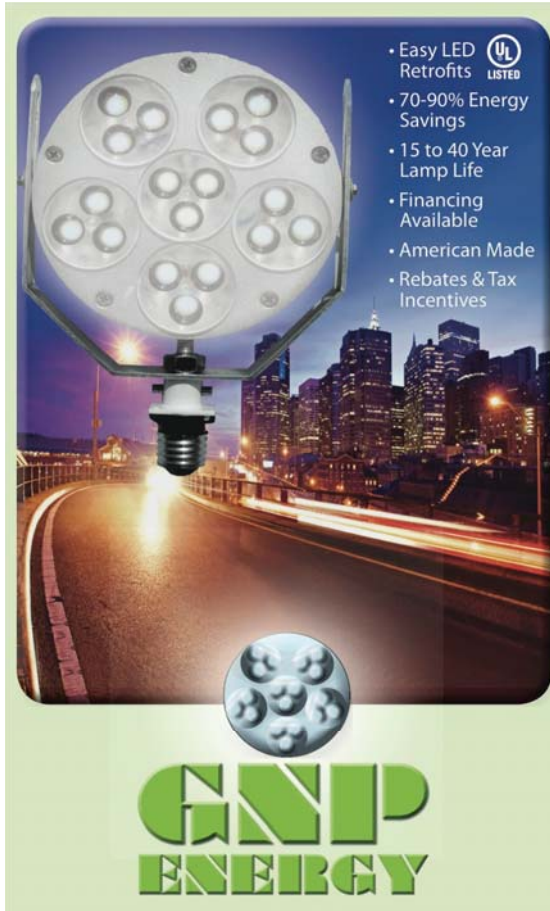

ANNOUNCING 0% FINANCING

GREEN SAVINGS MUNICIPAL FINANCE

Now GNP Energy brings another innovation to assist with implementing projects for Cities, School and Park districts, States, Counties, Colleges and more with - Green Savings Municipal Financing.

GNP Energy Municipal Finance offers the benefit of moving forward on projects today with no down payment, and recognize up to a full year of energy savings before making your first payment!

GNP Energy also works with your local utility company to facilitate any additional rebate programs which may be available. This makes an energy project more affordable and enables entities to get a return on investment in less time.

Contact your GNP Energy Representative for more information today. ***Special For qualified TIPS/TAPS members**

Benefits:

- 100% Project Financing
- Operational Savings Covers Cost
- More Savings For Faster ROI
- No Payment For 1 Year
- Longer Terms - 3, 5 & 7 Years
- Enhances Budget Planning
- Quick Approval Times
- Demonstrates Green Leadership

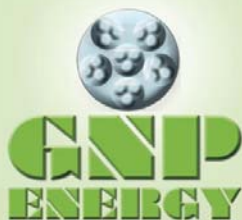

www.GNPenergy.com

GNP Announces Cutting Edge Financing for Qualifying Entities

GNP Energy is on the cutting edge of LED lighting conversions for commercial, industrial, and municipal infrastructure. *Our Patented line of high quality USA Manufactured LED lighting systems saves customers 70-90% on electric and last upwards of 20 years!* We will continue to be on the cutting edge of high quality green technology which saves money and improves quality of life as we have now for over 20 years.

*For a limited time GNP Energy Municipal Finance is offering three (3) years same as cash. To find out if your municipality qualifies simply email: info@gnpenergy.com for details and determining factors. HURRY! This offer may expire at any time.

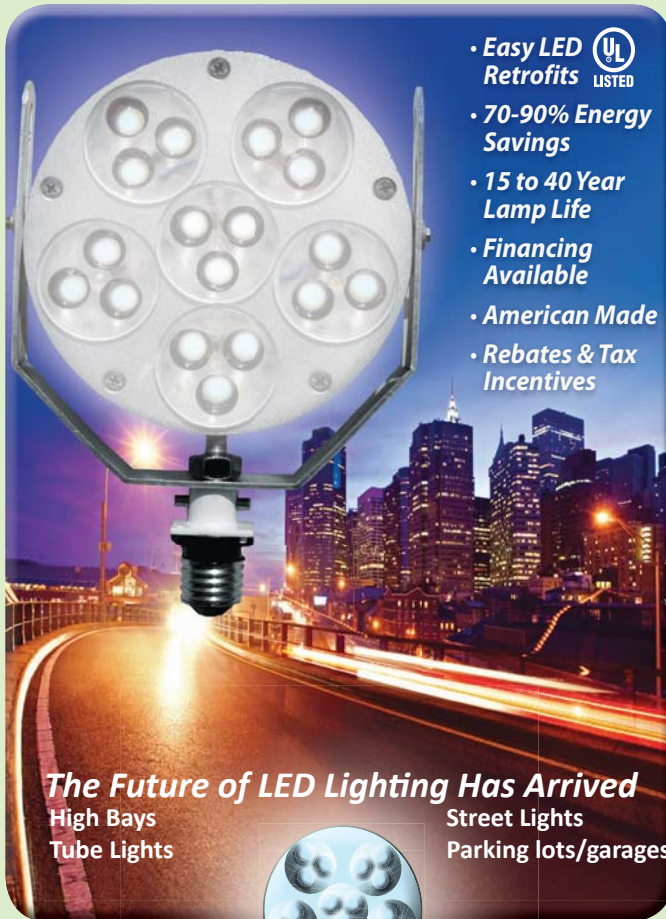

- **Easy LED**  **Retrofits**
- **70-90% Energy Savings**
- **15 to 40 Year Lamp Life**
- **Financing Available**
- **American Made**
- **Rebates & Tax Incentives**

The Future of LED Lighting Has Arrived

High Bays
Tube Lights

Street Lights
Parking lots/garages



0% Financing
NO Payment
for 1 Year!

*Special for qualifying TIPS/TAPS members



www.gnpenergy.com

312-970-1LED(1533) email:info@gnpenergy.com



GNP Energy LED Modules



Universal LED Modules

Application Guide

December 2013



GNP Energy LED 5400

One Module for Every Application

Solstice Scalable LED Modules

Recessed Lighting



Wallpacks



Area Lights





GNP Energy LED Customers



Mercedes-Benz



HONDA

Before w/400 MH

After

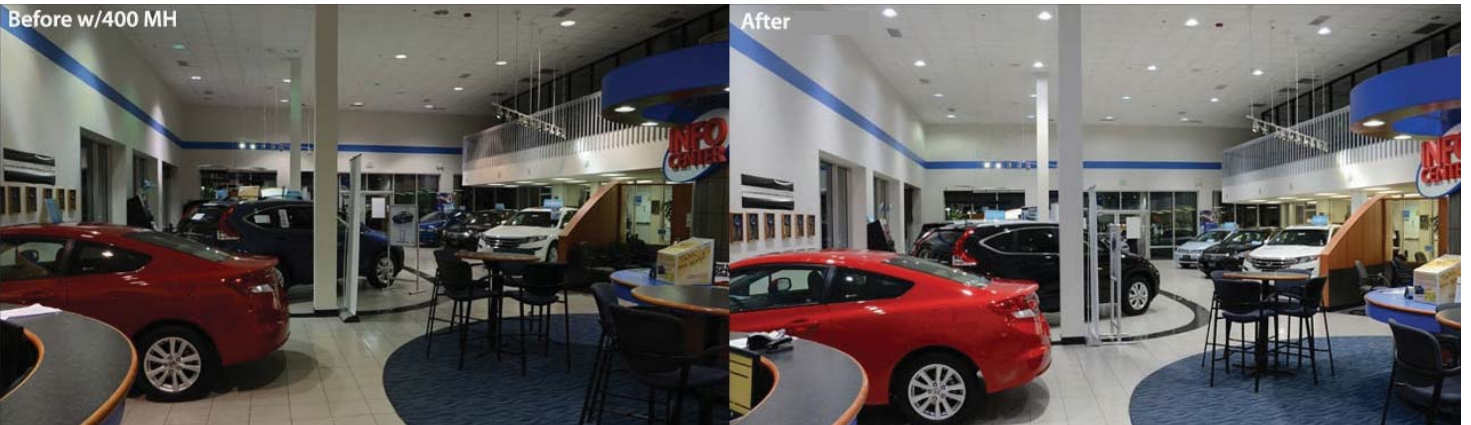



Simply Universal

2 Solstice LED Modules, Replace ANY HID, Period.

GNP Energy LED is an LED lighting design and manufacturing company based out of Florida. Our success is attributed to quality products, sound business practices, and loyalty to our national and international rep firms and distributors. Our company strives to always uphold our motto, "Simply Universal".

Our Solstice LED modules are perfect for LED retrofit kits and for new fixtures used in commercial and industrial lighting applications. Of the 500,000,000 HID bulbs in the USA alone, GNP Energy modules 5400 and 2700M, can replace every one of them, while producing the highest quality light in any fixture.

With the introduction of Life Sync smart technology, our modules are now intelligent. Monitoring their environment, Solstice modules run at optimum settings without damaging themselves, thus extending their life expectancies. Life Sync also takes care of lumen depreciation issues by slowly ramping lumen output to supplement any losses resulting from natural degradation.

Table of Contents

- Intro to GNP2
- Solstice LED Modules.....3-4
- Optics.....5
- Color Temperatures.....6
- Life Sync Smart Technology.....7
- Philips Luxeon T LED Chips.....8
- Forced Air Thermal Management.....9
- Retrofit: Yoke vs Plate.....10
- Scalability.....11
- Passive Cooling Thermal Management....12
- Power Mode Selection.....13
- Wireless Sensor Module and Program.....14
- Drivers.....15
- Warranty.....16





Solstice Module

The Brightest and Most Intelligent GNP5400 and GNP2700M

Lowering lighting cost by up to 70% and boasting such innovative features as universal compatibility, Life Sync smart technology, adjustable power modes, complete scalability, advanced optics, and color temperature options, our Solstice LED modules are Simply Universal!



Universal Compatibility

GNP retrofit options are compatible with virtually every fixture, including recessed and track lighting. With fewer parts and easier assembly, these smaller and lighter weight modules provide both the fixture manufacturer, as well as the end user, with lower overall costs. Superior active cooling coupled with proprietary thermal management design, ensures the module maintains efficiency in high temperatures, provides color consistency, and ensures low light degradation throughout its' life expectancy of 100,000 hours.

Life Sync Smart Technology

With the introduction of Life Sync smart technology, our modules are now intelligent. Monitoring their environment, Solstice modules run at optimum settings without damaging themselves, thus extending their life expectancies. Life Sync also takes care of lumen depreciation issues by slowly ramping lumen output to supplement any losses resulting from natural degradation. Learn more on page 7.

Power Modes

On board dip switches provide power selection capabilities for OEM fixture manufacturers and lighting designers who wish to adjust power and brightness in the field, according to specific applications. Additionally, on board energy savings program 561 is provided, and when activated, dims the modules automatically during off peak hours without using external controls. This system saves the equivalent of 1,100 hours of operating time per fixture, per year. Learn more on page 13.

Scalability

Solstice modules have the benefit of being completely scalable by allowing multiple modules to be installed in one fixture, if necessary. Both retrofit fixtures and brand new Solstice LED units are ordered and built to the requirements of each application. Learn more on page 11.

Advanced Optics

Advanced optic lenses in our Solstice modules provide the ability to customize light output to the modules' surrounding environment. These specialized lenses can send light directly where it is needed, reducing dark spots, wasted lumens, and unwanted light pollution. Learn more on page 5.

Color Temperature Options

Solstice modules offer seven color temperature options ranging from 2700K to 5700K. Technical specifications of color temperatures found on page 6.

Technical Specifications

Product	Body Color	CCT [K]	CRI [Ra]	Rated Life [L70] [h]	Output Setting	Drive Current [mA]	Rated Lumens [Lm]	Rated Watts [W]
Solstice Series Modules								
GNP 5400	White	5700	70	100,000	HO	900	13164	130
					HI	700	9447	95
					MH	525	8999	85
					ML	350	7814	75
GNP 2700M	White	5700	70	100,000	HI	700	5910	60
					MH	600	4594	50
					ML	500	3742	40
					Lo	400	2679	30

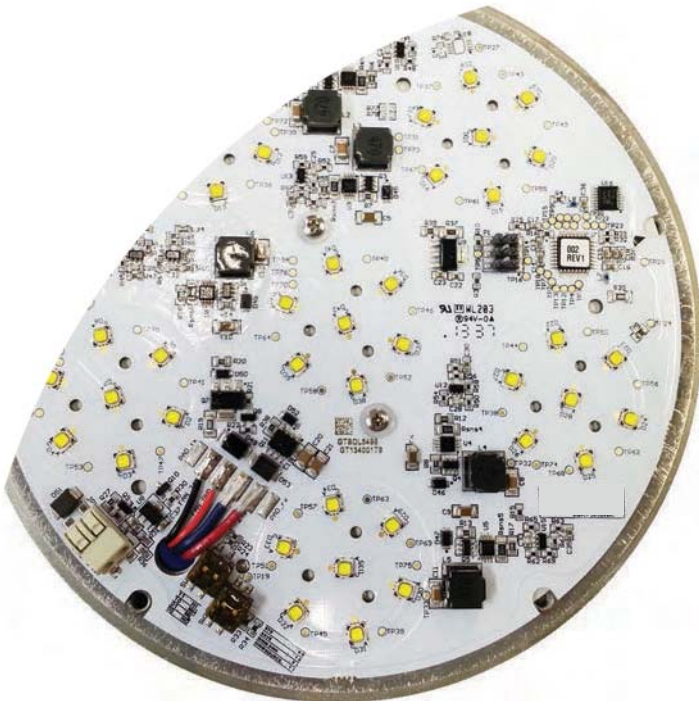

GNP-5400

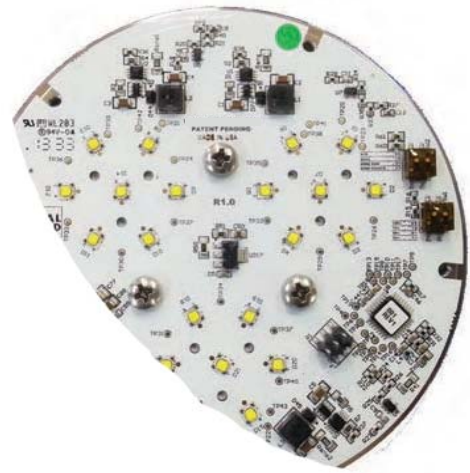

GNP-2700M

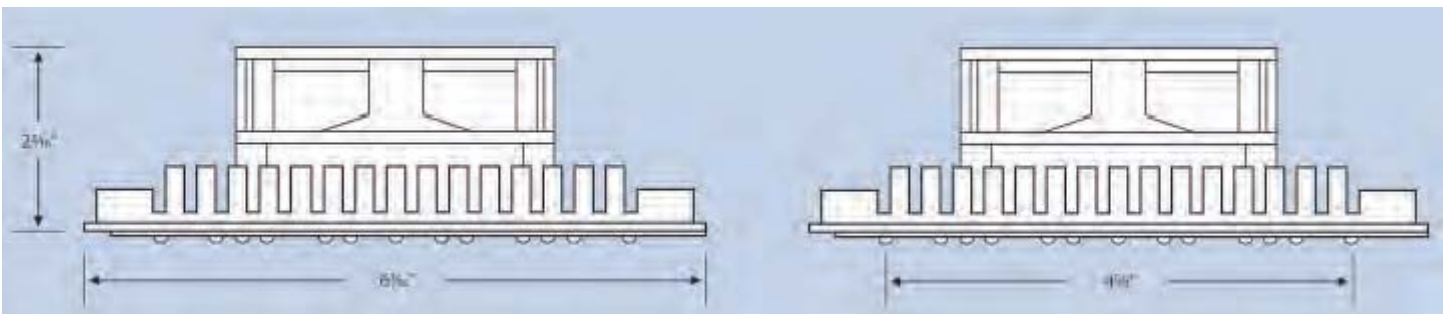



Seamless Optics

Optimize the Module for the Application



Seven-up optics are designed to perfectly fit the Solstice module's Philips Lumiled Luxeon T LED clusters. Precise lens integration preserves lumens and prevents vibration. Solstice module optics provide a large variety of distribution patterns to meet the needs of each unique application.

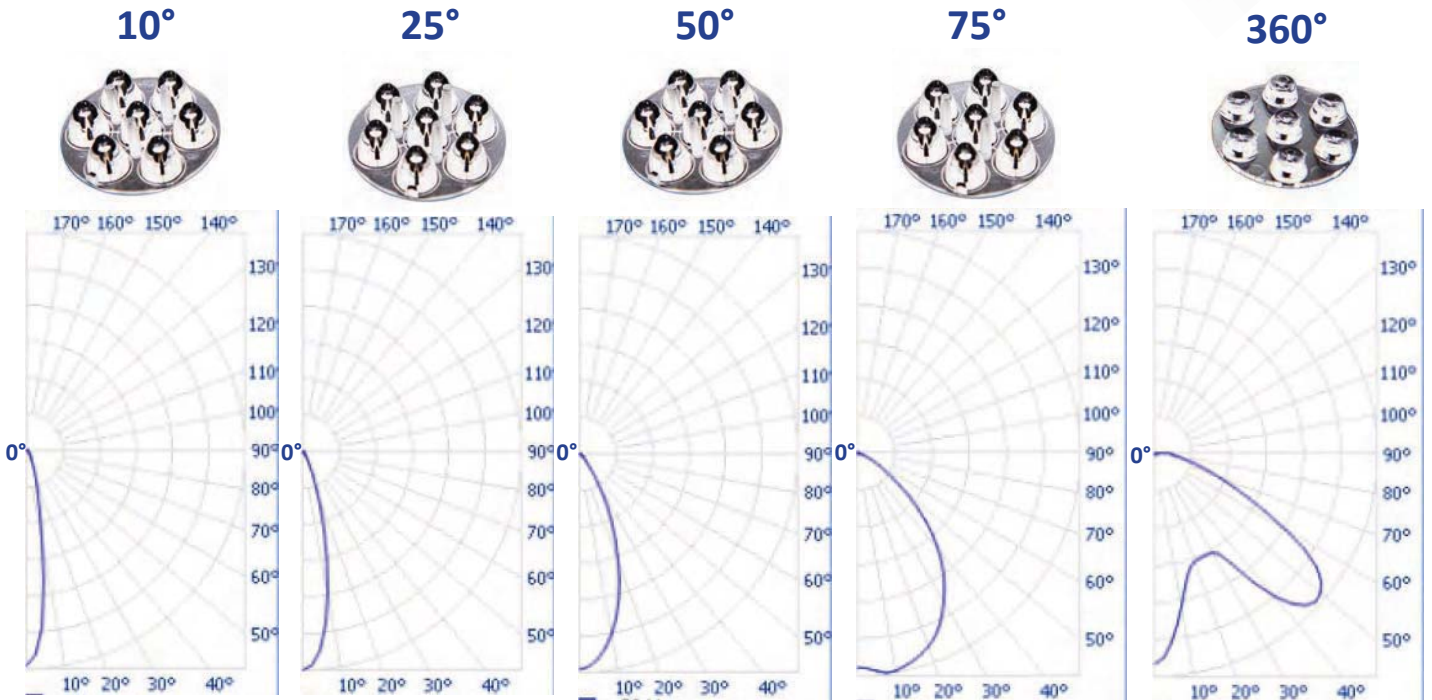

Type II

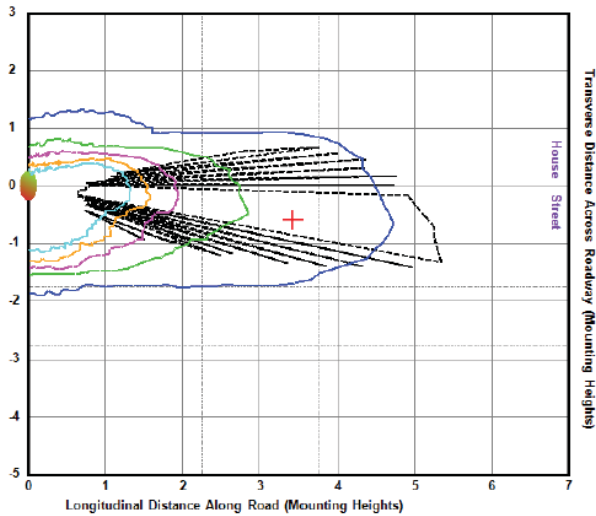

Type III

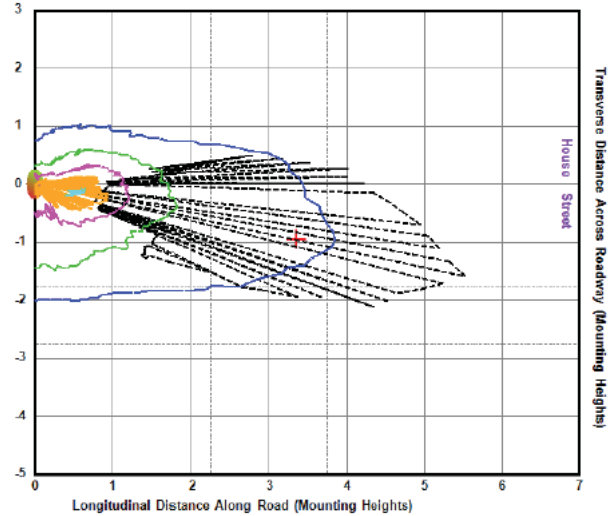

Color Temperature Options

Optimize the **Color** for the **Application**

GNP2700M

Name	Description	CRI	FLUX	Color Temperature	Sticker Color
GNP2700M-RD	Mini 27 Philips LED	80	190	3500K	Red
GNP2700M-BL	Mini 27 Philips LED	80	190	4000K	Blue
GNP2700M-BR	Mini 27 Philips LED	80	190	5000K	Brown
GNP2700M-GR	Mini 27 Philips LED	70	220	5700K	Green
GNP2700M-YW	Mini 27 Philips LED	70	210	4000K	Yellow
GNP2700M-OR	Mini 27 Philips LED	80	170	2700K	Orange
GNP2700M-PR	Mini 27 Philips LED	95	130	3000K	Purple

GNP5400

Name	Description	CRI	FLUX	Color Temperature	Sticker Color
GNP5400-RD	5400 Philips LED	80	190	3500K	Red
GNP5400-BL	5400 Philips LED	80	190	4000K	Blue
GNP5400-BR	5400 Philips LED	80	190	5000K	Brown
GNP5400-GR	5400 Philips LED	70	220	5700K	Green
GNP5400-YW	5400 Philips LED	70	210	4000K	Yellow
GNP5400-OR	5400 Philips LED	80	170	2700K	Orange
GNP5400-PR	5400 Philips LED	95	130	3000K	Purple









Life Sync Technology

Optimize the Module for the Environment

System Information

Life Sync uses advanced programming and technology to automatically make minuscule changes in the system according to the environment. This real-time maintenance ensures optimal performance and protects the life of the system.

-  Optimal for all Environments
-  Protects Life of the System
-  Supplements Natural Lumen Depreciation for 70,000hrs
-  Maintains Cool Operating Temperature
-  Safety Circuits Keep the Module in the Safe Zone

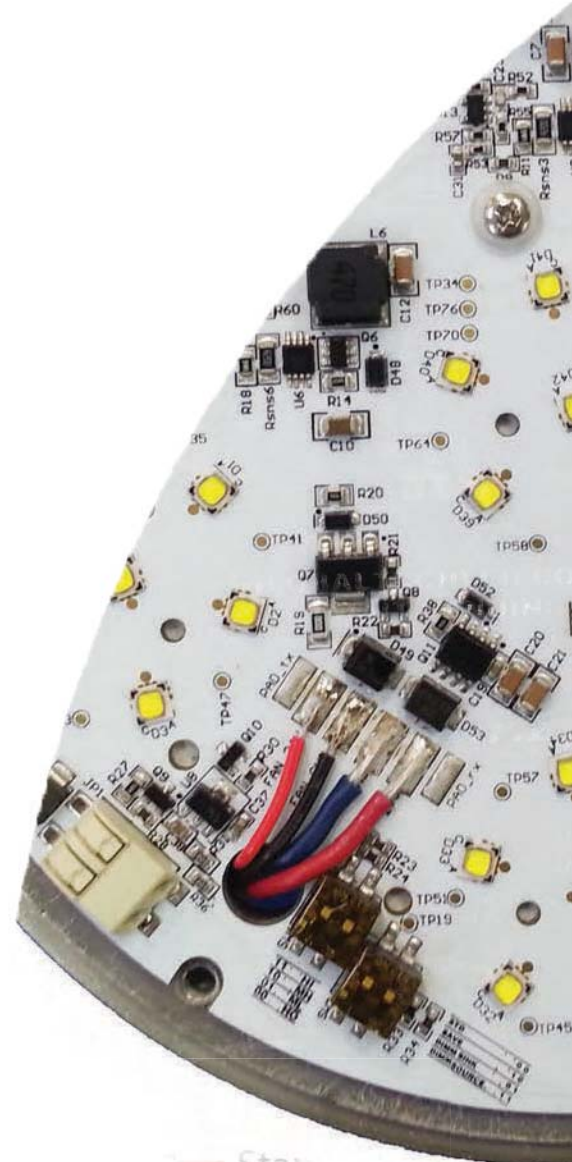

Lumen Depreciation Chart
Life Sync VS Standard *

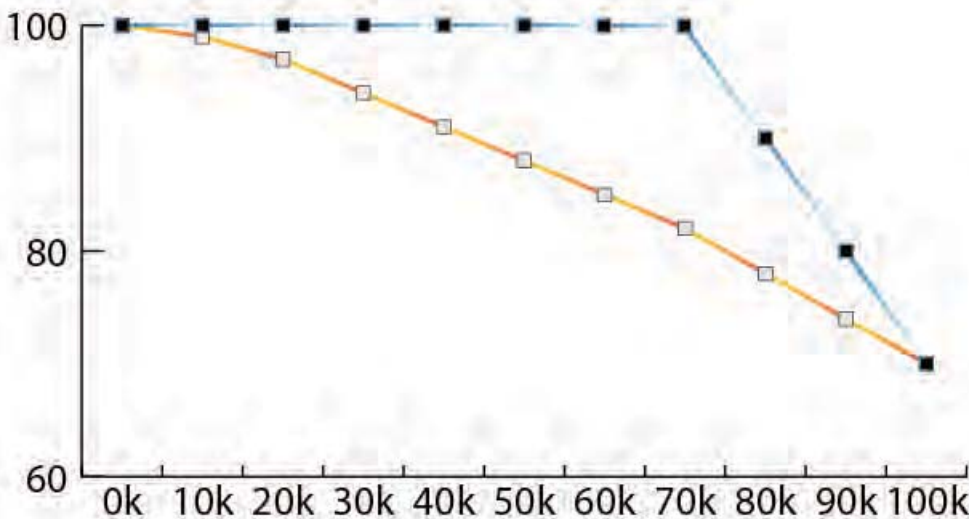

*For Display Purposes Only

Luxeon T LED Chips

The Brightest Chip for the Smartest Module



LUXEON® T Emitters

LUXEON® T emitters are illumination grade LEDs designed to deliver high efficacy with high flux density to enable tight beam control in directional and high lumen applications. With freedom from binning and with leading performance, LUXEON T emitters allow system optimization by blending the perfect combination of high efficacy and low system cost. With tight Correlated Color Temperature control, LUXEON T ensures consistency in system color point.

Features

- Freedom from Binning – 3 and 5 SDCM
- Hot tested at T_j 85°C
- Typical V_f of 2.7V and lowest thermal resistance, 3K/W
- Proven reliability
- Exceeds ENERGY STAR lumen maintenance requirements
- UL-recognized component [E3525 I9] with level 4 enclosure consideration

Benefits

- Delivers color consistency
- Ensure in application performance
- Optimized for efficacy driven applications
- Superior efficacy and light output

Key Applications

- Lamps
- Downlights
- Indoor
- Highbay and Lowbay
- Outdoor
- Architectural



Forced Air Thermal Solution

Optimize the Module for the Retrofit

System Information

Using a fan to force air through the heat sink provides an optimal level of active cooling by transporting excess heat away from the critical components on the circuit board. This viable active cooling solution for high brightness LEDs is inherently low in energy consumption, flexible enough to fit into a small space, and has an expected life (100,000hrs) matching that of the Luxeon LEDs. This system is used in retrofits to compensate for the lack of passive heat transfer in older fixtures.



Before

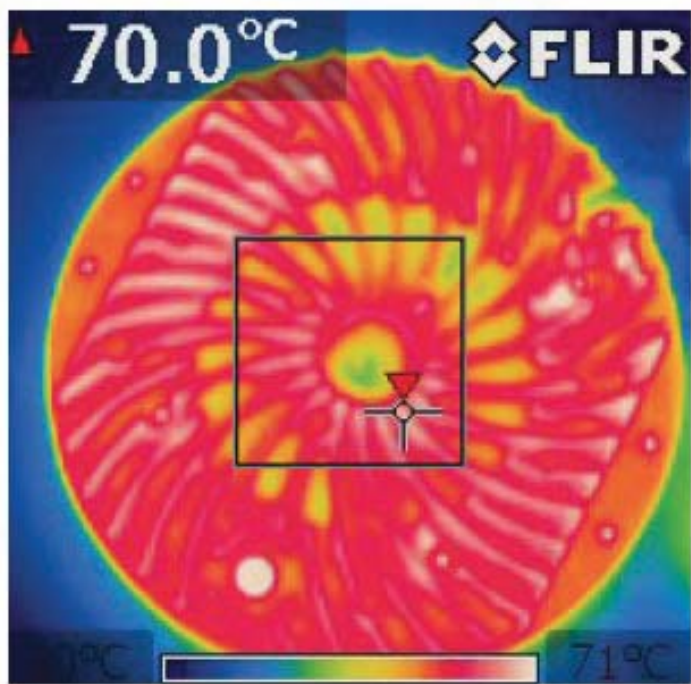

After

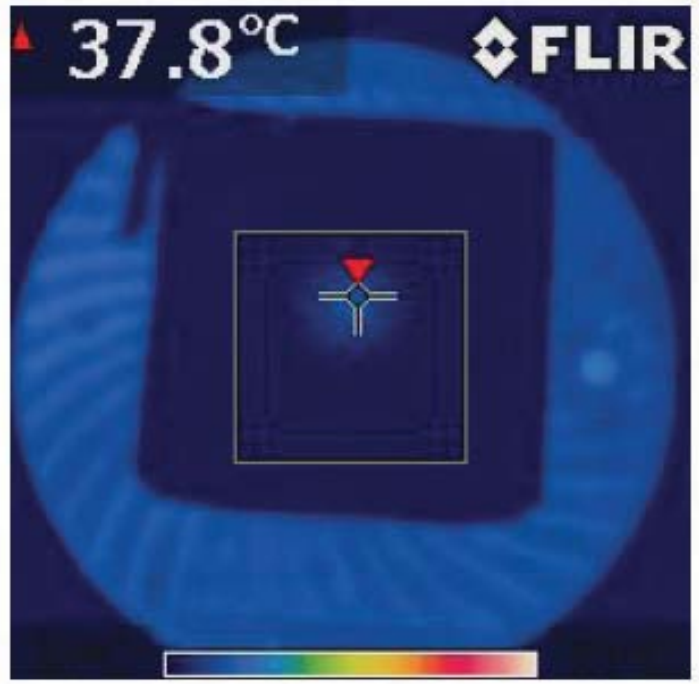

Retrofit Systems

Optimize the Module for the **Fixture**

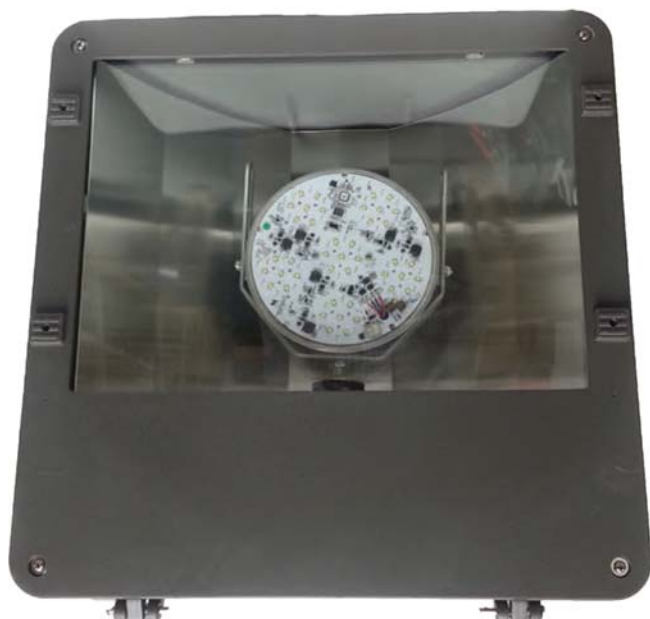

The Yoke Retrofit Bracket

With only three pieces, the yoke retrofit is the most universal mounting solution available. The threaded rod can be made to any length, optimizing the bracket for the fixture. The same bracket and rod (without the yoke) is used for finial applications or situations where a threaded rod would be a better mounting option.



The Plate Retrofit

GNP Energy LED has predesigned plates to fit almost any fixture. However, if a fixture you would like to retrofit doesn't fit one of our existing designs, we'll make one that will. Simply send us a sample fixture or the fixture dimensions, and our engineers will customize a plate for you.





Scalability

Optimize the **Modules** for the **Application**

Raising the Power

GNP modules have the benefit of being completely scalable. Both retrofit fixtures and brand new GNP LED units are ordered and built for the requirements of the application. This brilliant scaling system gives complete flexibility to adapt to the specific lighting environment.



Passive Cooling Solution

Optimize the Module for the **Fixture**



System Information

GNP Energy LED's passive cooling solution is an innovative fixture design incorporating a massive heat sink open to the outside air, transferring heat away from the circuit board at a rate unparalleled by any other passive cooling system on the market.





Power Mode Selection

Optimize the Module for the Application

Program Dip switch:

Program Selection - You can currently select 1 of 2 programs, as indicated by the dot allocation on the left side of the Dip Switch.

Functions:

STD:

A default setting unit is on at all times.

561 energy saver program (sav):

When this option is selected it allows the customer to operate outdoor lamps at 100% output for the first 5 hours of operation, dimming 50% for 6 late evening hours, than ramping back up to 100% output for the last hour of the evening. This useful program saves 3 hours of operation per night which results in savings over 1,100 hours per year!

Dimm Sink (default):

This selection is to be used when a motion sensor or dimming switch are active. Sink means that you are using a dimming ballast or controller that provides the 10v power so the control device adjusts the voltage to your needs.

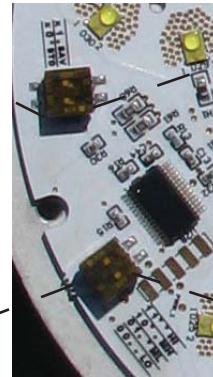
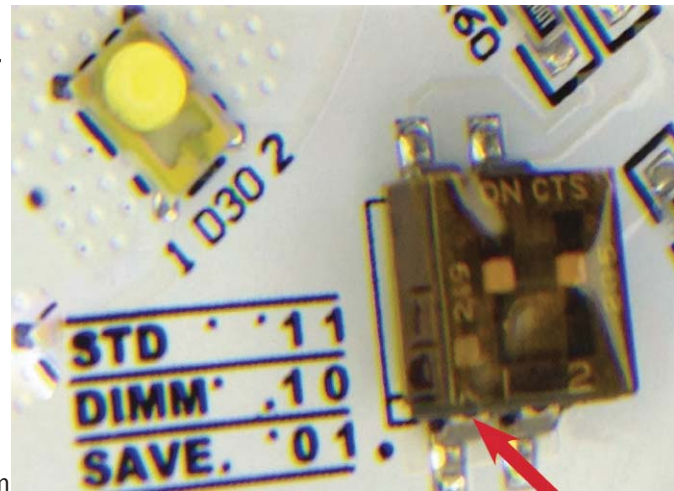

Wattage Dip switch:

Program Selection - You can currently select 1 of 4 wattage setting, as indicated by the dot allocation on the right side of the Dip Switch.

Both models feature 4 wattage selections:
5400- High Output, High, Med High, and Med Low
2700M- High, Med High, Med Low and Low

When both switches are positioned at the center of the board this indicates that you will be performing at the highest level of output.

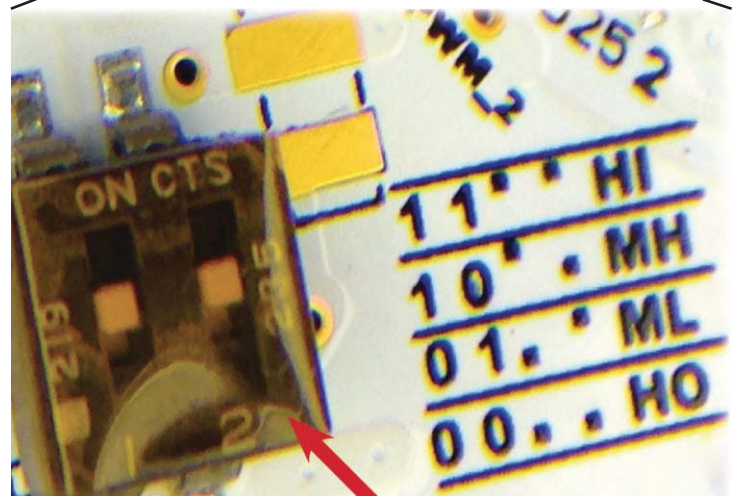

Please Refer to page 4 for Technical Specifications of the Wattage Selections for both Modules

Wireless Sensor Module

Optimize the Module for the Application



GNP Energy LED optional Wireless Module which facilitates Dimming and Instant On/Off Control using either Photocell or Motion Sensor or both. It is engineered with simple mapping software, and utilizes radio protocols for Zigbee, Synapse or others typically found in the industry.

When a motion sensor is engaged the Solstice is turned ON to 100% Output for 15 minutes. When no motion is detected after 15 minutes the Solstice can be set to either 20% or 50% Dimming or OFF. The Photocell or Motion Sensor must be installed within 500 feet of the Solstice Product using (20AWG) wiring for 0-10vdc sensor controls.

The system is setup at installation and is automatically optimized to provide high performance for the Solstice LED product. The Module integrates seamlessly with most of the major manufacturers of 0-10 VDC sensors such as Lutron, SensorSwitch, WattStopper.

Programming the Wireless Module:

Our unique selectable dip-switch identifies the task. The 5-dip switch input selector tells the Wireless Module what the control task is going to be. We provide a detailed list of devices with corresponding switch selections. The control selection is a 10-dip switch selector where you code who is following who. Switch 1-5 controls 1 device, and 6-10 controls a second device. In some situations, you may require 2 control devices controlling the same fixture. For example, let's say you have a motion sensor and you want it to control 2 fixtures. You would first set the input switch to designate a motion sensor and 2 light sources. On the control side you would configure all three devices with the same code (1-5). At this point, the 2 light sources will be controlled by the motion sensor: simple!

The controller does not need to be connected to the Internet in order for the system to work. In most cases, once the system is configured, the need to reconfigure the settings is minimal. For those clients that wish to have more control on a daily basis, the system can be set up using the Internet. Additional equipment will be required to operate the system along with yearly maintenance fees. This option will provide the remote monitoring of lights, collection of fixture data, such as temperature, service hours, energy usage, etc. and makes it easy to view or control lighting over the Internet.



Drivers

Optimize the Module for the Application

LEDs have evolved into a practical, flexible light source for a wide variety of illumination applications. Common LED products available in the market today are configured in a series-parallel array – designed to be powered by a suitable 24vdc driver – which allows flexibility to connect variable load levels. These operating voltages have become the standard in the industry.

- Limited output voltage and current plus isolation for safe operation
- UL Outdoor Damp location rated - Fully potted for moisture resistance and thermal IP 66 benefits
- Compact size design facilitates new simplified retrofit application as well as low-profile fixture design
- Low temperature operation allows for use in any outdoor application Performance (-40°C)
- Generous high temperature margin flexibility to facilitate fixture design capability (+60°C)
- Tightly regulated output Consistent light output across line (1% line, 5% load) and load levels
- The Solstice unit can be used for Solar Applications without the need for external drivers or inverters due to regulating our current on the PCB Board.
- A 5-year limited warranty*, solely on material, for new products and for end users, from the industry's most trusted component maker

Brands:

GNP Energy LED utilizes drivers from Rhoal, Fullam, Inventronics, and Meanwell. Utilizing multiple driver brands allows us to customize the modules to not only the application but also the fixture and the units immediate environment.





GNP Energy LED Warranty

GNP Energy LED warrants its Solstice LED engine and all components excluding driver for a period of (10) years from purchase date with proper registration by end user. Click [here](#) to register your product. In the event of no or incomplete registration, it will default to (5) years. Drivers and Eco-Line Products are under warranty for (5) years. GNP Energy LED will determine any unit defective if one or more of the following occurs.

Any individual LED or bank of LEDs do not light,

This warranty is conditioned upon proper storage, installation, use and maintenance. LED chips have a sealed lens, broken top lenses on LED chip, scuffs or other apparent signs of mishandling may void warranty.

GNP Energy LED may repair the damage at an additional cost. Estimate will be given prior to repair. This warranty is not applicable to any Solstice Unit which is not installed and operated in accordance with the current edition of The National Electric Code (NEC), the Standards for Safety of Underwriters' Laboratory, Inc. (UL), the Standards for the American National Standards Institute (ANSI), and with GNP Energy instructions and guidelines.

This warranty is not applicable to any product subjected to abnormal stresses and operating conditions. GNP Energy LED, LLC. shall correct any defects, at GNP Energy LED, LLC. option, by either repairing any defective part or parts or by replacing any defective part or parts or by making available a new replacement LED unit. The conditions of any tests concerning any Solstice Product which is claimed to have not performed to this warranty shall be mutually agreed upon in writing and GNP Energy LED, LLC. shall be notified of, and may be represented at any such tests. This express limited warranty is extended by GNP Energy LED, LLC. only to the original or first end-user purchaser. Warranty claims are to be made in accordance with GNP Energy LED, LLC. Published Warranty Service Program.

LABOR COSTS ASSOCIATED WITH WARRANTABLE LED MODULE REPLACEMENT. GNP Energy LED may pay labor costs on a job with a 3% or greater failure rate due to a product defect, up to \$25 (twenty five dollars) per unit at GNP's discretion, associated with replacement of product deemed warrantable upon inspection of returned goods up to one year from date of purchase. Invoices for labor must be sent to GNP Energy LED along with RGA (return goods authorization), and product to be inspected for warranty claim. If product defect is considered warrantable upon GNP inspection, GNP Energy LED will reimburse labor expenses up to \$25 per LED module. Projects asking for Labor cost reimbursements must first get approval from GNP and be issued an RGA that includes labor costs. GNP will not be responsible for equipment rental or other additional costs that may occur. *This program is subject to change at GNP's discretion.

NO IMPLIED STATUTORY WARRANTY OF MERCHANTABILITY OR FITNESS FOR A PARTICULAR PURPOSE SHALL APPLY BEYOND THE AFOREMENTIONED WARRANTY PERIOD. The foregoing warranty is exclusive of all other statutory, written or oral warranties, and no other warranties of any kind, statutory or otherwise, are given or herein expressed. This warranty sets forth GNP Energy LED, LLC. responsibilities regarding the Solstice LED unit and claimant's exclusive remedy.

LIMITATION OF LIABILITY. GNP Energy LED, LLC. will not under any circumstances whether as a result of breach of contract, breach of warranty, tort, strict liability or otherwise be liable for consequential, incidental, special or exemplary damages including but not limited to, loss of profits or revenues, loss of use of LED Unit or any other goods or associated equipment or damage to any associated equipment, cost of capital, cost of substitute products, facilities of services, down time cost, or claims of claimant's customers. GNP Energy LED, LLC. liability on any claim of any kind for any loss or damages arising out of, resulting from or concerning any aspect of this agreement of from the product or services furnished hereunder shall not exceed the price of the specific LED product which gives rise to the claim. This warranty gives the claimant specific legal rights. The claimant may also have other rights which vary from state to state.

Microwave sensor T8 LED Tube



CE RoHS FC

Advantage

- New technology, sensor and smart IC are integrated inside tubes, no need additional ballast.
- GNP special internal isolated power driver design, high watt available(25W), adjusted in delay time, sensor area, Min watt. 100% high voltage- resistance test, more safe.
- No ambient temperature nor noise interruption like PIR or voice-controlled, sensor area at least 10m.
- Special gridding circuit design, any individual LED failure will not cause other LEDs working.

Feature

- Saving up 90% more than fluorescent tube, 60% more than normal LED T8 .
- Meet the Europe and USA standard of UL,CE, RoHS, FCC certification.
- No Hg, Pb or other hazardous materials, no radiation, environment friendly.
- No frequency flash, instant startup, no hurting eyes.

Principle

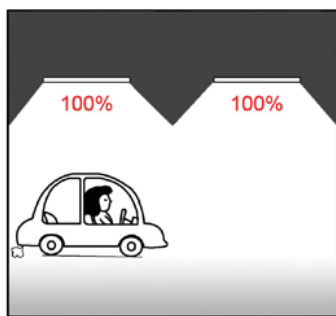

When car or people come,
100% light

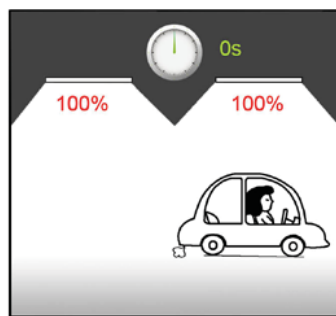

Keep 100% light before car or
people leave



20s after car or people left,
30% light

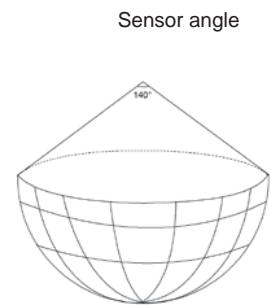

- Radar controlled, called Doppler effect. To test ambient movement intelligently, auto-adjust work state.
- When driving a car closer and closer(5-10meters, adjustable), auto-sensor receive signal and transmit to let light fully work at 100% (25W), its illumination equals to 60W fluorescent.
- After car parked and people left, auto-sensor will automatically turn down at 30%(adjustable) for energy saving.

Application

- Widely used in basement, parking lots, warehouse, corridors, passageway, elevator, bus stop, villa and other places where need 24 hours lighting.



Parameter

Type	GNPC-T8-06					
Length	600mm	1200mm	1200mm	1500mm	1500mm	1800mm
Movement power	9W	18W	20W	20W	25W	25W
Silence power (adjustable)	2.5W	5W	6W	6W	7.5W	7.5W
LED qty (Epistar SMD2835)	60pcs	105pcs	105pcs	105pcs	150pcs	150pcs
Lumens	>920lm	>1820lm	>1980lm	>1980lm	>2470lm	>2470lm
Sensor area	5-10m (adjustable)					
Sensor angle	140 degree					
Lighting last	20s (adjustable)					
React time	0.5s					
Working voltage	AC85-277V					
Lighting angle	120 degree					
CRI	>75Ra					
Colors Temp.	3000-7500K(Warm White/Neutral White/Pure White/Cool White)					
Power factor	>0.92					
Lifespan	≥30000H					
Material	AL (good quality for heat dissipation) +PC					
Working Temp.	-20~+60°C					

Test Report of GNPC-T8-06-1500mm-25W (6000k-Transparent Cover) IES

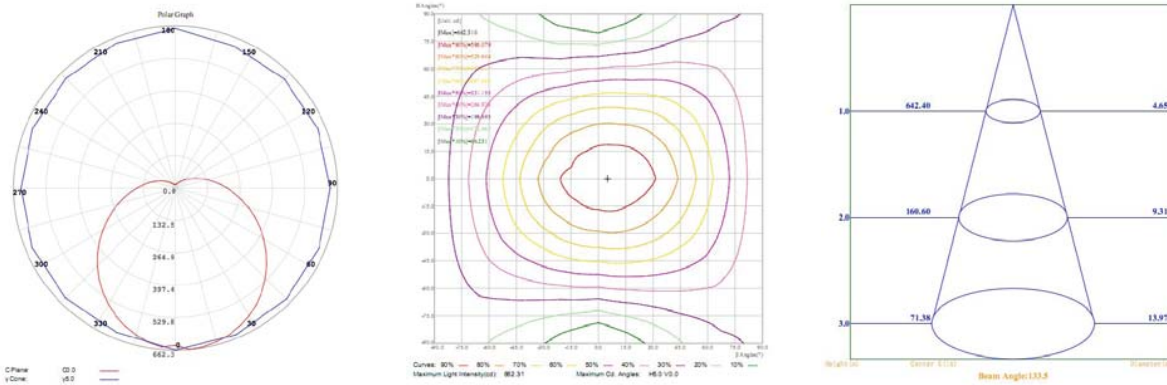

Decaying diagram

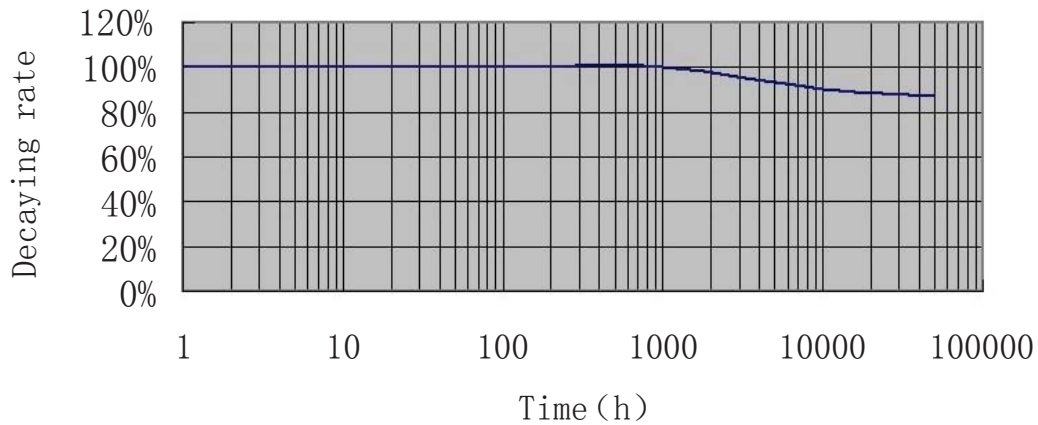

Colors Temperature



WARNING! (Two tubes are better installed more than 3 meters, or sensor area will be shorter.)

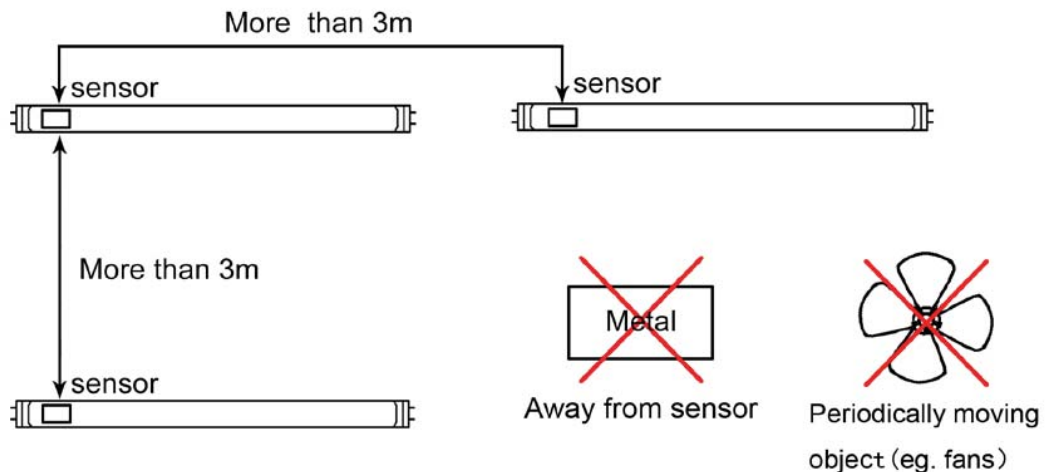

Spectrum Test Report of 100% Light

HPLLED Fast Spectrophotometer Test Report

LED Test Report

Product Mark

Product Type :GNPC-T8-06-1500mm-25W
Temperature :25'C
Operator :HYK

Manufacturer :GNP Energy
Humidity :51%
Test Date :2013-02

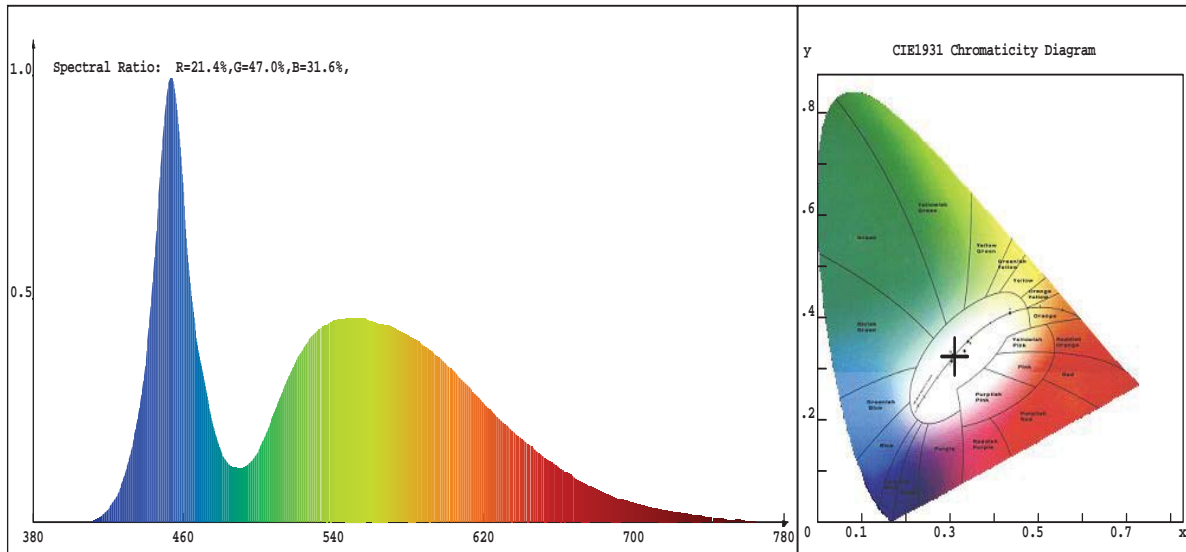

Chroma Parameters

Chro.Coord.:x=0.3113 y=0.3254 u=0.1982 v=0.3108 duv=0.0020
CCT: 6612K Dominant Wave.:487.0nm Purity:8.0%
Flux RGB Ratio:R=12.5%,G=83.7%,B=3.8% Peak Wave:453.5nm Half Width:21.3nm

Rending Index:Ra= 76.1

R1 =74	R2 =81	R3 =81	R4 =76	R5 =74	R6 =72	R7 =86	R8 =65
R9 =0	R10=51	R11=71	R12=41	R13=76	R14=89	R15=72	

Photo Parameters

Flux:2480.4lm Effi.:98.82lm/W Radiant:5504.4mW Iv:0.0mcd

Ele. Parameters

Voltage:U=220.100V Current:I=0.1182A
Power:P=25.1W Power Factor:PF=0.965

Instrument state

Instrument:Hopoo HP8000S	Integral Time: 26.379ms	VPeak: 15174
VDark: 1286	Scan Range: 380-780nm	Product ID: 201205106

Spectrum Test Report of 30% Light

HPLLED Fast Spectrophotometer Test Report

LED Test Report

Product Mark

Product Type :GNPC-T8-06-1500mm-25W
Temperature :25°C
Operator :HYK

Manufacturer :GNP Energy
Humidity :51%
Test Date :2013-02

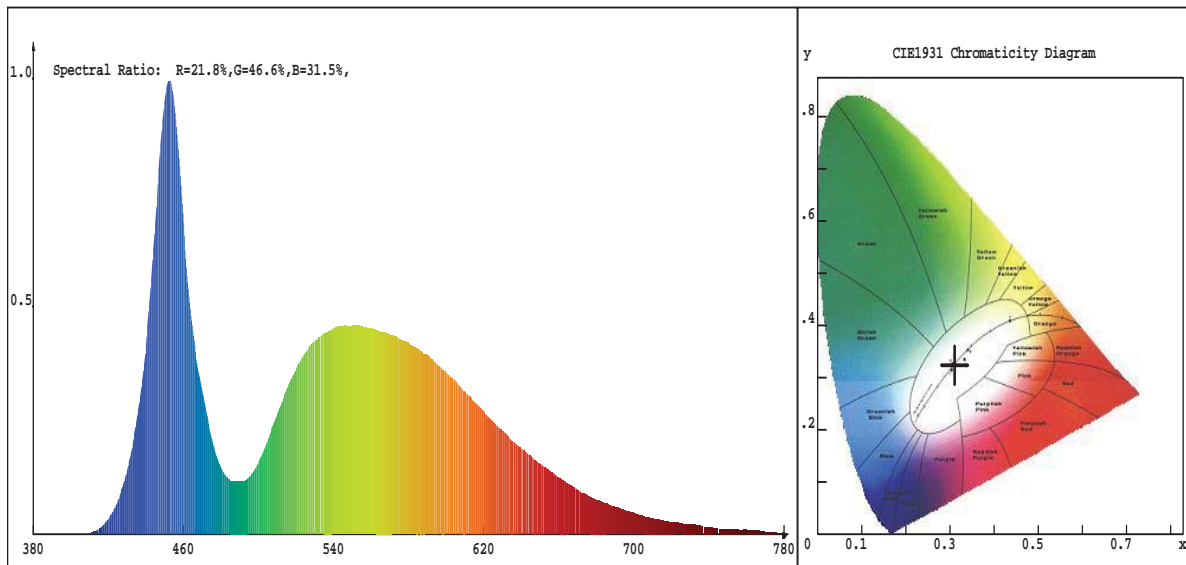

Chroma Parameters

Chro.Coord.:x=0.3113 y=0.3240 u=0.1987 v=0.3103 duv=0.0013
CCT: 6628K Dominant Wave.:486.1nm Purity:8.2%
Flux RGB Ratio:R=12.6%,G=83.7%,B=3.7% Peak Wave:452.5nm Half Width:21.7nm

Rending Index:Ra= 76.0

R1 =75	R2 =81	R3 =81	R4 =75	R5 =74	R6 =70	R7 =86	R8 =67
R9 =0	R10=50	R11=71	R12=41	R13=76	R14=89	R15=73	

Photo Parameters

Flux:884.1lm Effi.:85.83lm/W Radiant:1876.5mW Iv:0.0mcd

Ele. Parameters

Voltage:U=220.100V Current:I=0.0670A
Power:P=10.30W Power Factor:PF=0.702

Instrument state

Instrument:Hopoo HP8000S	Integral Time: 78.807ms	VPeak: 15030
VDark: 1302	Scan Range: 380-780nm	Product ID: 201205106

Installation Instruction

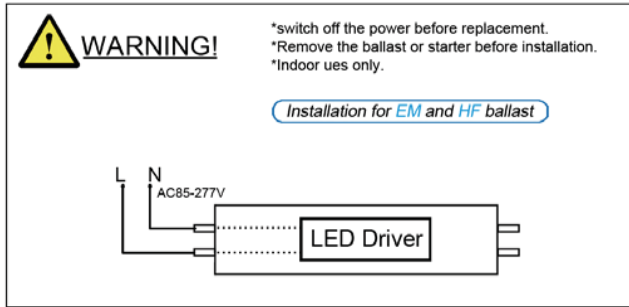

One side connection

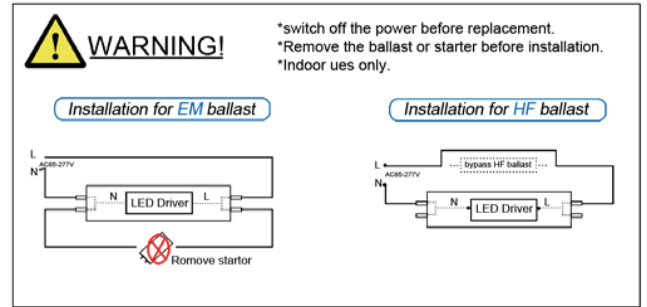

Two sides connection

Dimension(mm)

L:588mm/1198mm/1498mm/1764mm

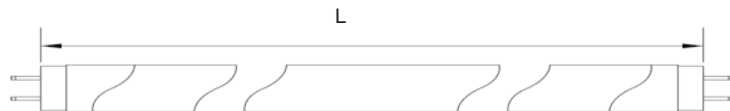

Packing Specification(mm)

One tube in one inner box, 25pcs inner box in one carton.

LED Tube length	Dimension of Outer carton =L*W*H	Total gross Weight
600mm	650*210*215mm	8.5kgs
1200mm	1250*210*215mm	16kgs
1500mm	1550*210*215mm	18.5kgs
1800mm	1850*210*215mm	21.5kgs

T8 LED TUBE

DLC UL SMD T8 LED Tube



DESIGNLIGHTS
CONSORTIUM



CLASSIFIED
C **UL** US
E362179



DESIGNLIGHTS
CONSORTIUM



CLASSIFIED
C **UL** US
E362179



FC C E

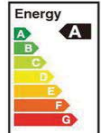

Features

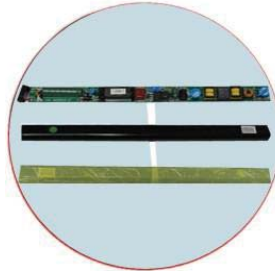

- ◆ DLC/UL(E362179) is certificated, LM80 & LM79 reports are available
- ◆ >100lm/W, CRI≥80
- ◆ Special circuit design, each LED works separately. If one fails, it does not affect other LED's work
- ◆ Double Insulation driver--- pass 3000V high voltage test @ 60s
- ◆ PF>0.98 @ 100V; PF>0.9 @277V
- ◆ 5 years warranty 50,000 hour rating

Specification

Color Temperature: 3000K, 4000K, 5000K

THD: ≤20%

Input Voltage: AC85-277V, 50/60Hz

Driver efficiency: ≥0.87

Temperature Characteristics: TA=25°C

Operating Temperature: -20~+50°C

Electrical / Optical Characteristics at TA=25°C

Length	Part No.	PC cover type	□Luminous flux (lm)□			Power	CRI	Viewing Angle
			3000K	4000K	5000K			
2FT (600mm)	T8-10W-60	Clear lens	1085lm	1155lm	1212lm	10W	≥80	120°
		Frosted lens	1025lm	1090lm	1152lm			
4FT (1200mm)	T8-18W-120	Clear lens	1980lm	2060lm	2155lm	18W	≥80	120°
		Frosted lens	1850lm	1940lm	2025lm			

Notes: Tolerance of measurement of luminous intensity±10%.

Dimension

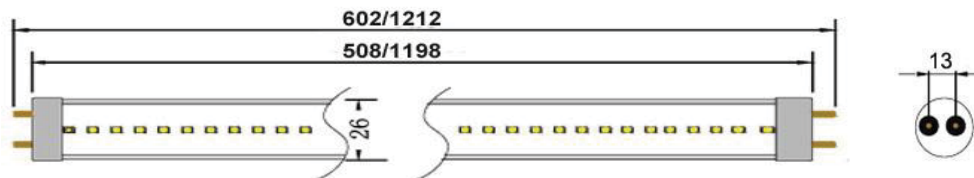

Notes: All dimension units are mm, and all dimension tolerance is ±1mm unless otherwise noted.

Luminance

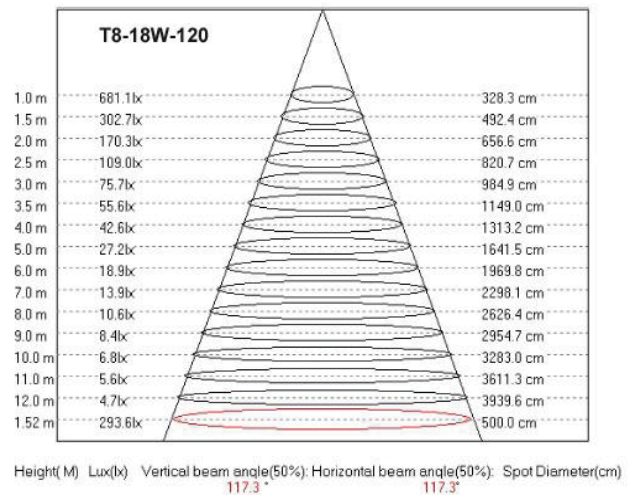
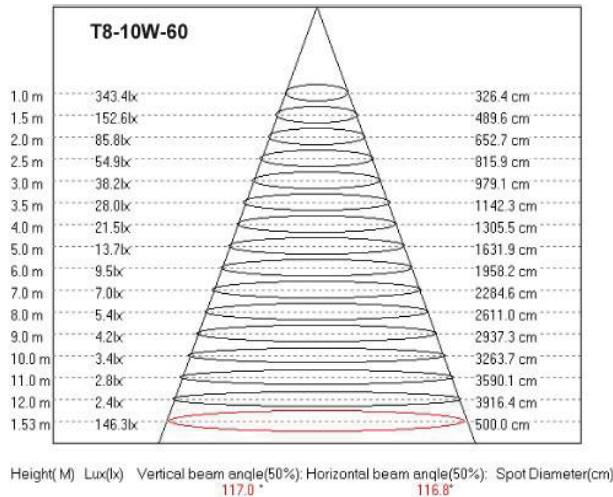

Light distribution curve

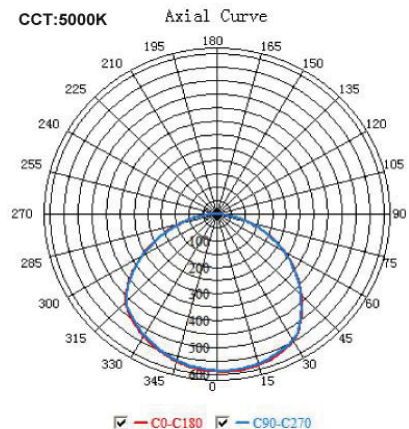
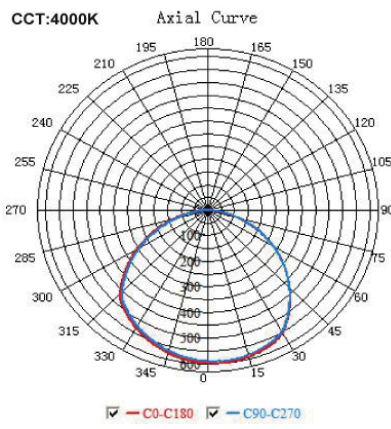
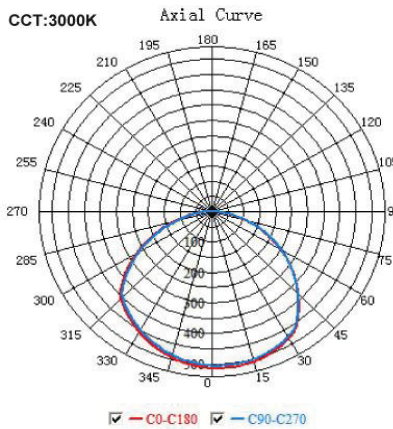

Installation



Before installation, please make sure the power is turned off

1. Use existing tombstones bracket, connect the power directly.



2. **Step 1:** Open the lamp holder cut off the wires at point “X” on the drawing;

Step 2: Connect the wires at point “O” on the drawing.

(1) Inductive ballast

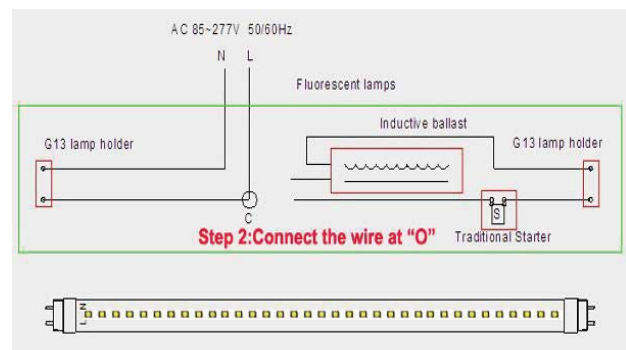
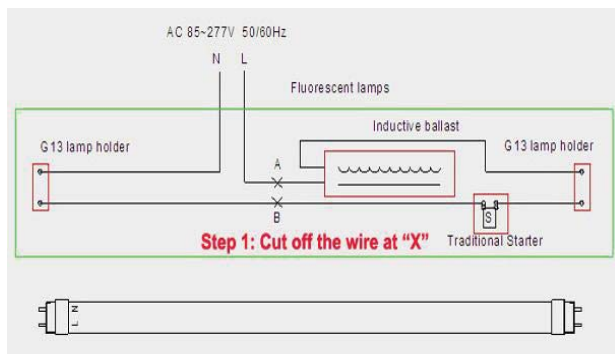

(2) Electronic ballast

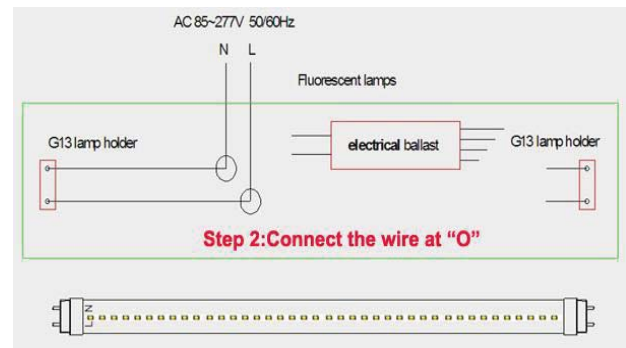
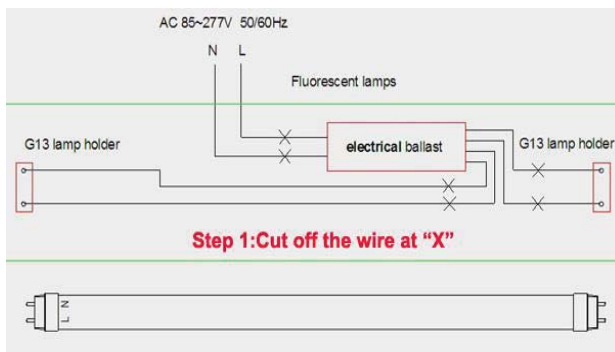

Application

Restaurants & Hotels, Shopping mall, Retail & Grocery, Show room, Airport, Project Gallery, Hospitals, Subway station, bus and train, warehouse etc.



Quality warranty

- ❖ 5 years warranty from the shipping date
- ❖ GNP Energy will replace all the failed products due to GNP Energy design/production quality central/material during the warranty period
- ❖ GNP Energy will bare all cost if the customer can help us to repair locally
- ❖ GNP Energy does not have the responsibility to compensate for any incorrect installation or artificial damage
- ❖ GNP Energy does not have the responsibility to compensate for damage occurred during the transit

Package

Part No.	Package dimension	N.W.	G.W.
T8-10W-60	25X6.5X7.5 in, 20pcs/carton	35.4lb/PCS	13.3 lb/CTN
T8-18W-120	48.5X6.5X7.5 in, 20pcs/carton	68.5lb/PCS	23.1 lb/CTN

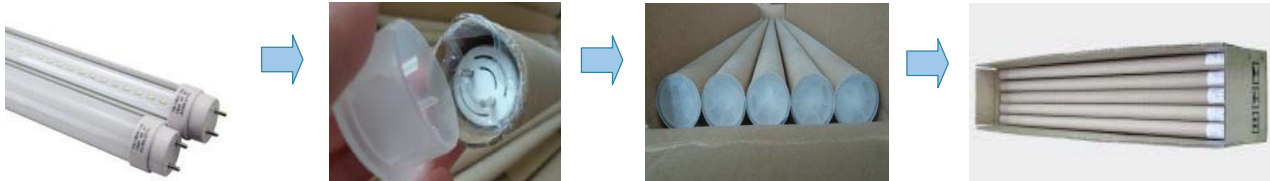

Contact information



GNP Energy

www.gnpenergy.com

Ph: 312-970-1LED

Fax: 866-286-1588

Construction:

- PC housing body and lens
- Stainless steel mounting brackets
- Stainless steel clips
- Isolated LED driver
- Epistar LED chips
- 1.2mm Aluminum heat sink

Electrical control:

- Input voltage range:100-277V AC
- Frequency:50/60Hz
- Power factor:>0.95
- Harmonic Distortion : THD<13%
- Protection: over-voltage , over-temperature, short circuit.
- Optional microwave motion sensor.
- Optional emergency battery pack

Warranty:

- 5 year warranty

Certificate:



Feature:

- Replaces maintenance & energy intensive HID&HPS fixtures
- With replaceable LED strip board, easy maintenance
- Poured in place gasket seals the enclosure from most hostile environments.
- Frosted diffuser giving an evenly distributed light output with no glare.
- Very tough diffuser resists breakage and reduces replacement and maintenance costs.
- IP65 Rating.
- Utilizes the LEDs with a lifespan of up to 50,000 hours
- Color Rendering Index(CRI)>80

Application:

Suitable for wet locations, Industrial Areas.



Parking Garages



Car Washes



Warehouse

Model	Wattage	Size	Dimensions(mm)	Voltage	Lumens	CCT(K)
GOG-LED220-SF	40W	4'	1210X102X83	100-277V	3800-4400lm	3000 4000
GOG-LED20-SF	20W	2'	610X102X83	100-277V	1900-2200lm	5000 6000

Construction:

- 1.2 mm Aluminum Body
- Poly carbonate Lens
- Isolated LED driver
- Epistar LED chips

Electrical control:

- Input voltage range:100-277V AC
- Frequency:50/60Hz
- Power factor:>0.95
- Harmonic Distortion : THD<13%
- Protection: over-voltage , over-temperature, short circuit.
- Optional microwave motion sensor.

Warranty:

- 5 year warranty

Certificate:



Feature:

- White aluminum body for greater heat dissipation
- With replaceable LED strip board, easy maintenance
- Frosted diffuser giving an evenly distributed light output with no glare.
- PC diffuser resists breakage and reduces replacement and maintenance costs.
- Utilizes the LEDs with a lifespan of up to 50,000 hours
- Color Rendering Index(CRI)>80
- Available in different lengths from 2' to 8'.
- Mounting: Wall ,Ceiling, Suspended.
- Compact size with excellent distribution fits multiple applications.

Application:

Suitable for Indoor Applications:

Schools , Hallways,
Commercial areas,
Industrial areas



Stairwells



Corridors



Shops

Model	Wattage	Size	Dimensions(mm)	Voltage	Lumens	CCT(K)
GOG-LED220-YPC	40W	4'	1314X125X40	100-277V	3800-4400lm	3000 4000
GOG-LED210-YPC	20W	2'	640X125X40	100-277V	1900-2200lm	5000 6000

Construction:

- 1.2 mm Aluminum Body
- Poly carbonate Lens
- Isolated LED driver
- Epistar LED chips

Electrical control:

- Input voltage range:100-277V AC
- Frequency:50/60Hz
- Power factor:>0.95
- Harmonic Distortion : THD<13%
- Protection: over-voltage , over-temperature, short circuit.
- Optional microwave motion sensor.
- Optional emergency battery pack

Warranty:

- 5 year warranty

Certificate:



Feature:

- White aluminum body for greater heat dissipation
- With replaceable LED strip board, easy maintenance
- Frosted diffuser giving an evenly distributed light output with no glare.
- PC diffuser resists breakage and reduces replacement and maintenance costs.
- utilizes the LEDs with a lifespan of up to 50,000 hours
- Color Rendering Index(CRI)>80
- Available in different lengths from 2' to 8'.
- Mounting: Wall ,Ceiling, Suspended.
- Compact size with excellent distribution fits multiple applications.

Application:

Suitable for Indoor Applications:

Schools , Hallways,
Commercial areas,
Industrial areas



Stairwells

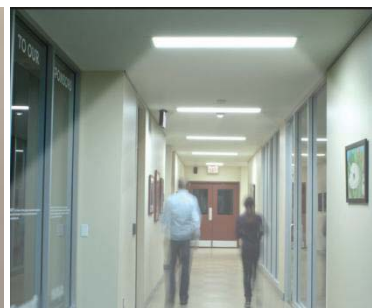

Hallways



Shops

Model	Wattage	Size	Dimensions(mm)	Voltage	Lumens	CCT(K)
GOG-LED220-FPC	40W	4'	1192X81X50	100-277V	3800-4400lm	3000 4000
GOG-LED210-FPC	20W	2'	582X81X50	100-277V	1900-2200lm	5000 6000

Construction:

- 1.2 mm Aluminum Body
- Poly carbonate Lens
- Isolated LED driver
- Epistar LED chips

Electrical control:

- Input voltage range:100-277V AC
- Frequency:50/60Hz
- Power factor:>0.95
- Harmonic Distortion : THD<13%
- Protection: over-voltage , over-temperature, short circuit.
- Optional microwave motion sensor.

Warranty:

- 5 year warranty

Certificate:



Feature:

- White aluminum body for greater heat dissipation
- With replaceable LED strip board, easy maintenance
- Frosted diffuser giving an evenly distributed light output with no glare.
- PC diffuser resists breakage and reduces replacement and maintenance costs.
- Utilizes the LEDs with a lifespan of up to 50,000 hours
- Color Rendering Index(CRI)>80
- Available in different lengths from 2' to 8'.
- Mounting: Wall ,Ceiling, Suspended.
- Compact size with excellent distribution fits multiple applications.

Application:

Suitable for Indoor Applications:

Schools , Hallways,
Commercial areas,
Industrial areas



Stairwells



Libraries



Schools

Model	Wattage	Size	Dimensions(mm)	Voltage	Lumens	CCT(K)
GOG-LED20-FPC	20W	4'	1192X60X53	100-277V	1900-2200lm	3000 4000 5000 6000

Construction:

- Stretching Aluminum Body.
- Tempered Glass Lens.
- Isolated LED driver.
- Epistar LED chips.
- 1.2mm Aluminum heat sink.

Electrical control:

- Input voltage range:100-277V AC
- Frenquency:50/60Hz
- Power factor:>0.95
- Harmonic Distortion : THD<13%
- Protection: over-voltage , over-temperature, short circuit.
- Optional emergency battery pack

Warranty:

- 5 year warranty

Certificate:



Feature:

- Stretching aluminum body for greater heat dissipation
- With replaceable LED strip board, easy maintenance
- Tempered glass diffuser resists breakage and reduces replacement and maintenance costs.
- utilizes the LEDs with a lifespan of up to 50,000 hours
- Color Rendering Index(CRI)>80
- Mounting: Wall ,Ceiling, Suspended.
- Compact size with excellent distribution fits multiple applications.

Application:

Suitable for
Outdoor and
special Applications



Tunnels



Bridges



Factories

Model	Wattage	Size	Dimensions(mm)	Voltage	Lumens	CCT(K)
GOG-LED220-X	40W	4'	1230X115X79	100-277V	3800-4400lm	3000 4000 5000 6000

Construction:

- 1.2 mm Aluminum Body
- Poly carbonate Lens
- Isolated LED driver
- Epistar LED chips

Electrical control:

- Input voltage range:100-277V AC
- Frenquency:50/60Hz
- Power factor:>0.95
- Harmonic Distortion : THD<13%
- Protection: over-voltage , over-temperature, short circuit.

Warranty:

- 5 year warranty

Certificate:



Feature:

- White aluminum body for greater heat dissipation
- With replaceable LED strip board, easy maintenance
- Frosted diffuser giving an evenly distributed light output with no glare.
- PC diffuser resists breakage and reduces replacement and maintenance costs.
- Utilizes the LEDs with a lifespan of up to 50,000 hours
- Color Rendering Index(CRI)>80
- Available in different lengths from 2' to 8'.
- Mounting: Wall ,Ceiling, Suspended.
- Compact size with excellent distribution fits multiple applications.

Application:

Suitable for Indoor Applications:

Commercial areas,
Industrial areas



Supermarket



Workshop



Storage Room

Model	Wattage	Size	Dimensions(mm)	Voltage	Lumens	CCT(K)
GOG-LED220-JLPC	40W	4'	1214X86X54	100-277V	3800-4400lm	3000 4000
GOG-LED210-JLPC	20W	2'	604X86X54	100-277V	1900-2200lm	5000 6000

Construction:

- 1.2 mm Aluminum Body
- 100% Acrylic frosted Lens
- Isolated LED driver
- Epistar LED chips

Electrical control:

- Input voltage range:100-277V AC
- Frequency:50/60Hz
- Power factor:>0.95
- Harmonic Distortion : THD<13%
- Protection: over-voltage , over-temperature, short circuit.
- Optional microwave motion sensor.

Warranty:

- 5 year warranty

Certificate:



Feature:

- White aluminum body for greater heat dissipation
- With replaceable LED strip board, easy maintenance
- Frosted diffuser giving an evenly distributed light output with no glare.
- Utilizes the LEDs with a lifespan of up to 50,000 hours
- Color Rendering Index(CRI)>80
- Available in different lengths from 2' to 8'.
- Mounting: Wall ,Ceiling, Suspended.
- Compact size with excellent distribution fits multiple applications.

Application:

Suitable for Indoor Applications:

Commercial areas,
Industrial areas



Supermarket



Office



Meeting Room

Model	Wattage	Size	Dimensions(mm)	Voltage	Lumens	CCT(K)
GOG-LED220-BG	40W	4'	1195X250X55	100-277V	3800-4400lm	3000 4000 5000 6000



LED-BPC-D Series LED Linear light

Construction:

- 1.2 mm Aluminum Body
- Poly carbonate Lens
- Isolated LED driver
- Epistar LED chips

Electrical control:

- Input voltage range:100-277V AC
- Frenquency:50/60Hz
- Power factor:>0.95
- Harmonic Distortion : THD<13%
- Protection: over-voltage , over-temperature, short circuit.
- Optional microwave motion sensor.

Warranty:

- 5 year warranty

Certificate:



Feature:

- White aluminum body for greater heat dissipation
- With replaceable LED strip board, easy maintenance
- Frosted diffuser giving an evenly distributed light output with no glare.
- PC diffuser resists breakage and reduces replacement and maintenance costs.
- Utilizes the LEDs with a lifespan of up to 50,000 hours
- Color Rendering Index(CRI)>80
- Available in different lengths from 2' to 8'.
- Mounting: Wall ,Ceiling, Suspended.
- Compact size with excellent distribution fits multiple applications.

Application:

Suitable for Indoor Applications:

Commercial areas,
Residential areas



Kitchen



Classroom



Residential place

Model	Wattage	Size	Dimensions(mm)	Voltage	Lumens	CCT(K)
GOG-LED220-BPC	40W	4'	1195X115X33	100-277V	3800-4400lm	3000 4000
GOG-LED210-BPC	20W	2'	585X115X33	100-277V	1900-2200lm	5000 6000

Construction:

- 1.2 mm Aluminum Body
- Poly carbonate Lens
- Isolated LED driver
- Epistar LED chips

Electrical control:

- Input voltage range:100-277V AC
- Frequency:50/60Hz
- Power factor:>0.95
- Harmonic Distortion : THD<13%
- Protection: over-voltage , over-temperature, short circuit.
- Optional ON/OFF Switch.
- Optional outlet.

Warranty:

- 5 year warranty

Certificate:



Feature:

- White aluminum body for greater heat dissipation
- With replaceable LED strip board, easy maintenance
- Frosted diffuser giving an evenly distributed light output with no glare.
- PC diffuser resists breakage and reduces replacement and maintenance costs.
- Utilizes the LEDs with a lifespan of up to 50,000 hours
- Color Rendering Index(CRI)>80
- Available in different lengths from 2' to 8'.
- Mounting: Wall ,Ceiling.
- Compact size with excellent distribution fits multiple applications.

Application:



Closet



Cabinet



Mirror light

Model	Wattage	Size	Dimensions(mm)	Voltage	Lumens	CCT(K)
GOG-LED20-BPC	20W	4'	1177X63X30	100-277V	1900-2200lm	3000 4000 5000 6000

GNP Energy Solar Powered LED Street Lights Silent Stand by Power Supply

Solar powered street lights are perfect for applications where there is no access to utility power. Perfect for remote areas, dark neighborhoods, or any area needing more light!

Solar powered street lights are perfect for anyone wanting to reduce electric bills. Return on investment* can be as little as 3 years (*including maintenance)

How does it work? The solar panel recharges the battery via a dusk to dawn photo sensor (solar charger) and powers a LED street light!



1 complete solar street light includes:

- (1) 240 solar panel
- (2) 125 ah maintenance free batteries -1800 duty cycle at 80 % depletion (5 years)
- (1) 15 position dusk to dawn solar charge controller
- (1) 50 watt LED (equal to 250 watt conventional bulb)

MC4 watertight connectors

Universal mounting 360 degree clamp works on any type of pole (ex. square, round, octagon, fluted, concrete, aluminum, wood...)

Clamps that allow adjustment (provides for any angle/ for any direction)

Dimensions: 30"H x 7.5"D x 14"W (7.5" depth provides lower center of gravity)

Some assembly required

Not included: pole

