

TIPS VENDOR AGREEMENT

Between FieldTurf USA, Inc. and
(Company Name)

THE INTERLOCAL PURCHASING SYSTEM (TIPS)

For

RCSP 170205 Synthetic or Natural Sports Fields, Courts or Tracks (JOC)

General Information

The Vendor Agreement (“Agreement”) made and entered into by and between The Interlocal Purchasing System (hereinafter referred to as “TIPS” respectfully) a government cooperative purchasing program authorized by the Region 8 Education Service Center, having its principal place of business at 4845 US Hwy 271 North, Pittsburg, Texas 75686. This Agreement consists of the provisions set forth below, including provisions of all Attachments referenced herein. In the event of a conflict between the provisions set forth below and those contained in any Attachment, the provisions set forth shall control.

The vendor Agreement shall include and incorporate by reference this Agreement, the terms and conditions, special terms and conditions, any agreed upon amendments, as well as all of the sections of the solicitation as posted, including any addenda and the awarded vendor’s proposal. Once signed, if an awarded vendor’s proposal varies or is unclear in any way from the TIPS Agreement, TIPS, at its sole discretion, will decide which provision will prevail. Other documents to be included are the awarded vendor’s proposals, task orders, purchase orders and any adjustments which have been issued. If deviations are submitted to TISP by the proposing vendor as provided by and within the solicitation process, this Agreement may be amended to incorporate any agreed deviations.

The following pages will constitute the Agreement between the successful vendors(s) and TIPS. Bidders shall state, in a separate writing, and include with their proposal response, any required exceptions or deviations from these terms, conditions, and specifications. If agreed to by TIPS, they will be incorporated into the final Agreement.

Definitions

PURCHASE ORDER is the TIPS member’s approval providing the authority to proceed with the negotiated delivery order under the Agreement. Special terms and conditions as agreed to between the vendor and TIPS member will be added as addendums to the PO. Items such as certificate of insurance, bonding requirements, small or disadvantaged business goals are some of the addendums possible.

Terms and Conditions

Freight

All deliveries shall be freight prepaid, F.O.B. destination and shall be included in all pricing offered unless otherwise clearly stated in writing.

Warranty Conditions

All supplies equipment and services shall include manufacturer's minimum standard warranty unless otherwise agreed to in writing. Vendor shall be an authorized dealer, distributor or manufacturer for all products. All equipment proposed shall be new unless clearly stated in writing.

Customer Support

The Vendor shall provide timely and accurate customer support to TIPS members. Vendors shall respond to such requests within one (1) working day after receipt of the request. Vendor shall provide training regarding products and services supplied by the Vendor unless otherwise clearly stated in writing at the time of purchase. (Unless training is a line item sold or packaged and must be purchased with product.)

Agreements

All Agreements and agreements between Vendors and TIPS Members shall strictly adhere to the statutes that are set forth in the Uniform Commercial Code as most recently revised.

Agreements for purchase will normally be put into effect by means of a purchase order(s) executed by authorized agents of the participating government entities.

Davis Bacon Act requirements will be met when Federal Funds are used for construction and/or repair of buildings.

Tax exempt status

A taxable item sold, leased, rented to, stored, used, or consumed by any of the following governmental entities is exempted from the taxes imposed by this chapter:(1) the United States; (2) an unincorporated instrumentality of the United States; (3) a corporation that is an agency or instrumentality of the United States and is wholly owned by the United States or by another corporation wholly owned by the United States;(4) the State of Texas; (5) a Texas county, city, special district, or other political subdivision; or (6) a state, or a governmental unit of a state that borders Texas, but only to the extent that the other state or governmental unit exempts or does not impose a tax on similar sales of items to this state or a political subdivision of this state. Texas Tax Code § 151.309.

Assignments of Agreements

No assignment of Agreement may be made without the prior written approval of TIPS. Payment can only be made to the awarded Vendor or vendor assigned dealer.

Disclosures

1. Vendor affirms that he/she has not given, offered to give, nor intends to give at any time hereafter any economic opportunity, future employment, gift, loan, gratuity, special discount, trip, favor or service to a public servant in connection with this Agreement.
2. Vendor shall attach, in writing, a complete description of any and all relationships that might be considered a conflict of interest in doing business with participants in the TIPS program.
3. The vendor affirms that, to the best of his/her knowledge, the offer has been arrived at independently, and is submitted without collusion with anyone to obtain information or gain any favoritism that would in any way limit competition or give an unfair advantage over other vendors in the award of this Agreement.

Renewal of Agreements

The Agreement with TIPS is for one (1) year with an option for renewal for additional consecutive years as provided in the solicitation. Total term of Agreement can be up to the number of years provided in the solicitation, if sales are reported through the Agreement and both parties agree.

Automatic Renewal Clauses Incorporated in Awarded Vendor Agreements with TIPS Members Resulting from the Solicitation and with the Vendor Named in this Agreement.

No Agreement for goods or services with a TIPS member by the awarded vendor named in this Agreement that results from the solicitation award named in this Agreement, may incorporate an automatic renewal clause with which the TIPS member must comply. All renewal terms incorporated in an Agreement by the vendor with the TIPS member shall only be valid and enforceable when the vendor receives written confirmation by purchase order or executed Agreement issued by the TIPS member for any renewal period. The purpose of this clause is to avoid a TIPS member inadvertently renewing an Agreement during a period in which the governing body of the TIPS member has not properly appropriated and budgeted the funds to satisfy the Agreement renewal. This term is not negotiable and any Agreement between a TIPS member and a TIPS awarded vendor with an automatic renewal clause that conflicts with these terms is rendered void and unenforceable.

Shipments

The Vendor shall ship ordered products within a commercially reasonable time after the receipt of the order. If a product cannot be shipped within that time, the Vendor shall notify TIPS and

the requesting entity as to why the product has not shipped and shall provide an estimated shipping date, if applicable. TIPS or the requesting entity may cancel the order if estimated shipping time is not acceptable.

Invoices

The Vendor or vendor assigned dealer shall submit invoices, to the TIPS participant. Each invoice shall include the TIPS participant's purchase order number. The shipment tracking number or pertinent information for verification of TIPS participant receipt shall be made available upon request. The Vendor or vendor assigned dealer shall not invoice for partial shipments unless agreed to in writing in advance by TIPS and the TIPS participant.

Payments

The TIPS participant will make payments directly to the Vendor or vendor assigned dealer at net 30 days after receiving invoice.

Pricing

The Vendor Agreements to provide pricing to TIPS and its participating governmental entities that is the lowest pricing available to like cooperative purchasing customers and the pricing shall remain so throughout the duration of the Agreement.

The Vendor agrees to promptly lower the cost of any product purchased through TIPS following a reduction in the manufacturer or publisher's direct cost to the Vendor. Price increases will be honored. However, the Vendor shall honor previous prices for thirty (30) days after written notification to TIPS of an increase.

All pricing submitted to TIPS shall include the participation fee, as provided in the solicitation, to be remitted to TIPS by the Vendor. Vendor will not show adding the fee to the invoice presented to customer. Failure to render the participation fee to TIPS shall constitute a breach of this agreement and shall be grounds for termination of this agreement and any other agreement held with TIPS.

Participation Fees

Vendor or vendor assigned dealer Agreements to pay the participation fee for all Agreement sales to TIPS on a monthly scheduled report. Vendor must login to the TIPS database and use the "Submission Report" section to report sales. The Vendor or vendor assigned dealers are responsible for keeping record of all sales that go through the TIPS Agreement. Failure to pay the participation fee will result in termination of Agreement. Please contact TIPS at tips@tips-usa.com or call (866) 839-8477 if you have questions about paying fees.

Indemnity

1. **Indemnity for Personality Agreements.** Vendor agrees to indemnify and hold harmless and defend TIPS, TIPS member(s), officers and employees, from and against all claims and suits for damages, injuries to persons (including death), property damages, losses, and expenses including court costs and attorney's fees, arising out of, or resulting from, Vendor's performance of this Agreement, including all such causes of action based upon common, constitutional, or statutory law, or based in whole or in part, upon allegations of negligent or intentional acts on the part of the Vendor, its officers, employees, agents, subcontractors, licensees, invitees, whether or not such claims are based in whole or in part upon the negligent acts or omissions of the TIPS, TIPS member(s), officers, employees, or agents.
2. **Indemnity for Performance Agreements.** The Vendor agrees to indemnify and hold harmless and defend TIPS, TIPS member(s), officers and employees from and against all claims and suits for damages, injuries to persons (including death), property damages, losses, and expenses including court costs and attorney's fees, arising out of, or resulting from, Vendor's work under this Agreement, including all such causes of action based upon common, constitutional, or statutory law, or based in whole or in part, upon allegations of negligent or intentional acts on the part of the Vendor, its officers, employees, agents, subcontractors, licensees, or invitees. Vendor further agrees to indemnify and hold harmless and defend TIPS, TIPS member(s), officers and employees, from and against all claims and suits for injuries (including death) to an officer, employee, agent, subcontractors, supplier or equipment lessee of the Vendor, arising out of, or resulting from, Vendor's work under this Agreement whether or not such claims are based in whole or in part upon the negligent acts or omissions of the TIPS, TIPS member(s), officers, employees, or agents.

Attorney's Fees--Texas Local Government Code § 271.159 is expressly referenced.

Pursuant to §271.159, TEXAS LOC. GOV'T CODE, in the event that any one of the Parties is required to obtain the services of an attorney to enforce this Agreement, the prevailing party, in addition to other remedies available, shall be entitled to recover reasonable attorney's fees and costs of court.

Multiple Vendor Awards

TIPS reserves the right to award multiple vendor Agreements for categories when deemed in the best interest of the TIPS membership. Bidders scoring 80% or above will be considered for an award. Categories are established at the discretion of TIPS.

State of Texas Franchise Tax

By signature hereon, the bidder hereby certifies that he/she is not currently delinquent in the payment of any franchise taxes owed the State of Texas under Chapter 171, Tax Code.

Miscellaneous

The Vendor acknowledges and agrees that continued participation in TIPS is subject to TIPS sole discretion and that any Vendor may be removed from the participation in the Program at any time with or without cause. Nothing in the Agreement or in any other communication between TIPS and the Vendor may be construed as a guarantee that TIPS participants will submit any orders at any time. TIPS reserves the right to request additional proposals for items already on Agreement at any time.

Purchase Order Pricing/Product Deviation

If a deviation of pricing/product on a purchase order occurs, TIPS is to be notified within 24 hours of receipt of order.

Cancellation for non-performance or Agreement deficiency

TIPS may terminate any Agreement if TIPS Members have not used the Agreement, or if purchase volume is determined to be “low volume” in any 12-month period. TIPS reserves the right to cancel the whole or any part of this Agreement due to failure by awarded vendor to carry out any obligation, term or condition of the Agreement. TIPS may issue a written deficiency notice to awarded vendor for acting or failing to act in any of the following:

- Providing material that does not meet the specifications of the Agreement;
- Providing work and/or material that was not awarded under the Agreement;
- Failing to adequately perform the services set forth in the scope of work and specifications;
- Failing to complete required work or furnish required materials within a reasonable amount of time;
- Failing to make progress in performance of the Agreement and/or giving TIPS reason to believe that awarded vendor will not or cannot perform the requirements of the Agreement; and/or
- Performing work or providing services under the Agreement prior to receiving a TIPS reviewed purchase order for such work.

Upon receipt of the written deficiency, awarded vendor shall have ten (10) days to provide a satisfactory response to TIPS. Failure to adequately address all issues of concern may result in Agreement cancellation. Upon cancellation under this paragraph, all goods, materials, work, documents, data and reports prepared by awarded vendor under this Agreement shall become the property of the TIPS Member on demand.

TIPS Member Purchasing Procedures

Purchase orders are issued by participating TIPS member to the awarded vendor indicating on the PO “Agreement Number”. Purchase Order is emailed to TIPS at tipspo@tips-usa.com.

- Awarded vendor delivers goods/services directly to the participating member.

- Awarded vendor invoices the participating TIPS member directly.
- Awarded vendor receives payment directly from the participating member.
- Awarded vendor reports sales monthly to TIPS (unless prior arrangements have been made with TIPS to report monthly).

Form of Agreement

If a vendor submitting an offer requires TIPS and/or TIPS Member to sign an additional agreement, a copy of the proposed agreement must be included with the proposal. In response to submitted supplemental Vendor Agreement documents, TIPS will review proposed vendor Agreement documents. Vendor's Agreement document shall not become part of TIPS's Agreement with vendor unless and until an authorized representative of TIPS reviews and approves it.

Licenses

Awarded vendor shall maintain in current status all federal, state and local licenses, bonds and permits required for the operation of the business conducted by awarded vendor. Awarded vendor shall remain fully informed of and in compliance with all ordinances and regulations pertaining to the lawful provision of services under the Agreement. TIPS reserves the right to stop work and/or cancel Agreement of any awarded vendor whose license(s) expire, lapse, are suspended or terminated.

Novation

If awarded vendor sells or transfers all assets or the entire portion of the assets used to perform this Agreement, a successor in interest must guarantee to perform all obligations under this Agreement. TIPS reserves the right to accept or reject any new party. A simple change of name agreement will not change the Agreement obligations of awarded vendor.

Site Requirements (when applicable to service or job)

Cleanup: Awarded vendor shall clean up and remove all debris and rubbish resulting from their work as required or directed by TIPS Member. Upon completion of work, the premises shall be left in good repair and an orderly, neat, clean and unobstructed condition.

Preparation: Awarded vendor shall not begin a project for which TIPS Member has not prepared the site, unless awarded vendor does the preparation work at no cost, or until TIPS Member includes the cost of site preparation in a purchase order.

Site preparation includes, but is not limited to: moving furniture, installing wiring for networks or power, and similar pre-installation requirements.

Registered sex offender restrictions: For work to be performed at schools, awarded vendor agrees that no employee of a sub-contractor who has been adjudicated to be a registered sex offender will perform work at any time when students are or reasonably expected to be present.

Awarded vendor agrees that a violation of this condition shall be considered a material breach and may result in the cancellation of the purchase order at the TIPS Member's discretion. Awarded vendor must identify any additional costs associated with compliance of this term. If no costs are specified, compliance with this term will be provided at no additional charge. Safety measures: Awarded vendor shall take all reasonable precautions for the safety of employees on the worksite, and shall erect and properly maintain all necessary safeguards for protection of workers and the public. Awarded vendor shall post warning signs against all hazards created by the operation and work in progress. Proper precautions shall be taken pursuant to state law and standard practices to protect workers, general public and existing structures from injury or damage.

Smoking

Persons working under Agreement shall adhere to local smoking policies. Smoking will only be permitted in posted areas or off premises.

Invoices

The awarded vendor shall submit invoices to the participating entity clearly stating "Per TIPS Agreement". The shipment tracking number or pertinent information for verification shall be made available upon request.

Marketing

Awarded vendor agrees to allow TIPS to use their name and logo within website, marketing materials and advertisement. Any use of TIPS name and logo or any form of publicity, inclusive of press release, regarding this Agreement by awarded vendor must have prior approval from TIPS.

Supplemental agreements

The entity participating in the TIPS Agreement and awarded vendor may enter into a separate supplemental agreement to further define the level of service requirements over and above the minimum defined in this Agreement i.e. invoice requirements, ordering requirements, specialized delivery, etc. Any supplemental agreement developed as a result of this Agreement is exclusively between the participating entity and awarded vendor. TIPS, its agents, TIPS members and employees shall not be made party to any claim for breach of such agreement.

Survival Clause

All applicable software license agreements, warranties or service agreements that were entered into between Vendor and Customer under the terms and conditions of the Agreement shall survive the expiration or termination of the Agreement. All Purchase Orders issued and accepted by Order Fulfiller shall survive expiration or termination of the Agreement.

Legal obligations

It is the responding vendor's responsibility to be aware of and comply with all local, state and federal laws governing the sale of products/services identified in this RFP and any awarded Agreement thereof. Applicable laws and regulations must be followed even if not specifically identified herein.

Audit rights

Awarded Vendor shall, at their sole expense, maintain appropriate due diligence of all purchases made by TIPS Member that utilizes this Agreement. TIPS and Region 8 ESC each reserve the right to audit the accounting for a period of three (3) years from the time such purchases are made. This audit right shall survive termination of this Agreement for a period of one (1) year from the effective date of termination. TIPS shall have authority to conduct random audits of Awarded Vendor's pricing that is offered to TIPS Members. Notwithstanding the foregoing, in the event that TIPS is made aware of any pricing being offered to eligible entities that is materially inconsistent with the pricing under this agreement, TIPS shall have the ability to conduct the audit internally or may engage a third-party auditing firm. In the event of an audit, the requested materials shall be provided in the format and at the location designated by Region 8 ESC or TIPS.

Force Majeure

If by reason of Force Majeure, either party hereto shall be rendered unable wholly or in part to carry out its obligations under this Agreement then such party shall give notice and fully particulars of Force Majeure in writing to the other party within a reasonable time after occurrence of the event or cause relied upon, and the obligation of the party giving such notice, so far as it is affected by such Force Majeure, shall be suspended during the continuance of the inability then claimed, except as hereinafter provided, but for no longer period, and such party shall endeavor to remove or overcome such inability with all reasonable dispatch.

Services

When applicable, performance bonds and payment bonds will be required on construction or labor required jobs. Awarded vendor will meet the TIPS member's local and state purchasing requirements. Awarded vendors may need to provide additional capacity as jobs increase. Bonds will not require that a fee be paid to TIPS. The actual cost of the bond will be a pass through to the TIPS member and added to the purchase order or Agreement.

Scope of Services

The specific scope of work for each job shall be determined in advance and in writing between TIPS Member and Awarded vendor. It is okay if the TIPS member provides a general scope, but the awarded vendor should provide a written scope of work to the TIPS member as part of the proposal.

Once the scope of the job is agreed to, the TIPS member will issue a PO and/or an Agreement with the estimate referenced as an attachment along with bond and any other special provisions agreed to for the TIPS member. If special terms and conditions other than those covered within this solicitation and awarded Agreements are required, they will be attached to the PO and shall take precedence over those in the base Agreement.

Project Delivery Order Procedures

The TIPS member having approved and signed an interlocal agreement, or other TIPS membership document, may make a request of the awarded vendor under this Agreement when the TIPS member has services that need to be undertaken. Notification may occur via phone, the web, email, fax, or in person.

Upon notification of a pending request, the awarded vendor shall make contact with the TIPS member as soon as possible, but must make contact with the TIPS member within two working days.

Scheduling of Projects

Scheduling of projects (if applicable) will be accomplished when the TIPS member issues a purchase order that will serve as "the notice to proceed". The period for the delivery order will include the mobilization, materials purchase, installation and delivery, design, weather, and site cleanup and inspection. No additional claims may be made for delays as a result of these items. When the tasks have been completed the awarded vendor shall notify the client and have the TIPS member inspect the work for acceptance under the scope and terms in the PO. The TIPS member will issue in writing any corrective actions that are required. Upon completion of these items, the TIPS member will issue a completion notice and final payment will be issued.

Support Requirements

If there is a dispute between the awarded vendor and TIPS member, TIPS or its representatives will assist in conflict resolution or third party (mandatory mediation), if requested by either party. TIPS, or its representatives, reserves the right to inspect any project and audit the awarded vendors TIPS project files, documentation and correspondence.

Incorporation of Solicitation

The TIPS Request for Proposals or the Request for Competitive Sealed Proposals solicitation and all associated documents and forms made part of the solicitation process, including any addenda, that resulted in the execution of this agreement are hereby incorporated by reference into this agreement as if copied verbatim.

Special Terms and Conditions

It is the intent of TIPS to Agreement with a reliable, high performance vendor to supply products and services to government and educational agencies. It is the experience of TIPS that the following procedures provide TIPS, the Vendor, and the participating agency the necessary support to facilitate a mutually beneficial relationship. The specific procedures will be negotiated with the successful vendor.

- **Agreements:** All vendor purchase orders and/or Agreements/agreements must be emailed to TIPS at tipspo@tips-usa.com. Should an agency send an order direct to vendor, it is the vendor's responsibility to forward the order to TIPS at the email above within 24 business hours and confirm its receipt with TIPS.
 - **Promotion of Agreement:** It is agreed that Vendor will encourage all eligible entities to purchase from the TIPS Program. Encouraging entities to purchase directly from the Vendor and not through TIPS Agreement is a violation of the terms and conditions of this Agreement and will result in removal of the Vendor from the TIPS Program.
 - **Daily Order Confirmation:** All Agreement purchase orders will be approved daily by TIPS and sent to vendor. The vendor must confirm receipt of orders to the TIPS member (customer) within 24 business hours.
 - **Vendor custom website for TIPS:** If Vendor is hosting a custom TIPS website, then updated pricing must be posted by 1st of each month.
 - **Back Ordered Products:** If product is not expected to ship within 3 business days, customer is to be notified within 24 hours and appropriate action taken based on customer request.
-

Term of Agreement is one year with renewal options for up to two additional years as provided in the solicitation.

TIPS Vendor Agreement Signature Form

RCSP 170205 Synthetic or Natural Sports Fields, Courts or Tracks (JOC)

Company Name FieldTurf USA, Inc.

Address 7445 Cote-de-Liesse, Suite 200

City Montreal, Quebec (Canada) State QC Zip H4T 1G2

Phone (800) 724-2969 Fax (514) 904-9311

Email of Authorized Representative eric.daliere@tarkettsports.com

Name of Authorized Representative Eric Daliere

Title President

Signature of Authorized Representative 

Date February 21, 2017

TIPS Authorized Representative Name Meredith Barton

Title Vice-President of Operations

TIPS Authorized Representative Signature 

Approved by ESC Region 8 

Date 3/23/2017

The Interlocal Purchasing System (TIPS Cooperative) Supplier Response

Bid Information		Contact Information		Ship to Information
Bid Creator	Mr. David Mabe General Manager	Address	Region VIII Education Service Center 4845 US Highway 271 North Pittsburg, TX 75686	Address
Email	david.mabe@tips-usa.com	Contact	Kim Thompson, TIPS Office Manager	Contact
Phone	+1 (903) 243-4759	Department Building		Department Building
Fax	+1 (866) 749-6674	Floor/Room		Floor/Room
Bid Number	170205 Addendum 1	Telephone	+1 (866) 839-8477	Telephone
Title	Synthetic or Natural Sports Fields, Courts or Tracks (JOC)	Fax	+1 (866) 839-8472	Fax
Bid Type	RFP	Email	bids@tips-usa.com	Email
Issue Date	2/2/2017 08:01 AM (CT)			
Close Date	3/17/2017 03:00:00 PM (CT)			

Supplier Information

Company FieldTurf USA, Inc.
 Address 175 N Industrial Blvd NE
 Calhoun, GA 30701

Contact
 Department
 Building
 Floor/Room
 Telephone (888) 209-0065 x246
 Fax
 Email

Submitted 3/15/2017 12:53:14 PM (CT)
 Total \$0.00

By submitting your response, you certify that you are authorized to represent and bind your company.

Signature Ross Hinrichs Email ross.hinrichs@fieldturf.com

Supplier Notes

Bid Notes

Bid Activities

Bid Messages

Bid Attributes

Please review the following and respond where necessary

#	Name	Note	Response
1	Yes - No	Disadvantaged/Minority/Women Business Enterprise - D/M/WBE (Required by some participating governmental entities) Vendor certifies that their firm is a D/M/WBE? Vendor must upload proof of certification to the "Response Attachments" D/M/WBE CERTIFICATES section.	No
2	Yes - No	Highly Underutilized Business - HUB (Required by some participating governmental entities) Vendor certifies that their firm is a HUB? Vendor must upload proof of certification to the "Response Attachments" HUB CERTIFICATES section.	No
3	Yes - No	The Vendor can provide services and/or products to all 50 US States?	Yes
4	States Served:	If answer is NO to question #3, please list which states can be served. (Example: AR, OK, TX)	
5	Company and/or Product Description:	This information will appear on the TIPS website in the company profile section, if awarded a TIPS contract. (Limit 750 characters.)	Synthetic Turf, Track And Tennis Courts and associated construction.
6	Primary Contact Name	Primary Contact Name	Eric Fisher
7	Primary Contact Title	Primary Contact Title	Director od Sales - SmartBuy
8	Primary Contact Email	Primary Contact Email	Eric.Fisher@smartbuycooperative.com
9	Primary Contact Phone	Enter 10 digit phone number. (No dashes or extensions) Example: 8668398477	503 563 6395
10	Primary Contact Fax	Enter 10 digit phone number. (No dashes or extensions) Example: 8668398477	503-692-8659
11	Primary Contact Mobile	Enter 10 digit phone number. (No dashes or extensions) Example: 8668398477	503-708-6548
12	Secondary Contact Name	Secondary Contact Name	Sarah Morehead
13	Secondary Contact Title	Secondary Contact Title	Director of Operations- SmartBuy
14	Secondary Contact Email	Secondary Contact Email	Sarah.Morehead@smartbuycooperative.com
15	Secondary Contact Phone	Enter 10 digit phone number. (No dashes or extensions) Example: 8668398477	503 563 6390
16	Secondary Contact Fax	Enter 10 digit phone number. (No dashes or extensions) Example: 8668398477	503-692-8659
17	Secondary Contact Mobile	Enter 10 digit phone number. (No dashes or extensions) Example: 8668398477	503-267-0165
18	Admin Fee Contact Name	Admin Fee Contact Name. This person is responsible for paying the admin fee to TIPS.	Sarah Morehead
19	Admin Fee Contact Email	Admin Fee Contact Email	Sarah.Morehead@smartbuycooperative.com

20	Admin Fee Contact Phone	Enter 10 digit phone number. (No dashes or extensions) Example: 8668398477	503 563 6390
21	Purchase Order Contact Name	Purchase Order Contact Name. This person is responsible for receiving Purchase Orders from TIPS.	Sarah Morehead
22	Purchase Order Contact Email	Purchase Order Contact Email	Sarah.Morehead@smartbuycooperative.com
23	Purchase Order Contact Phone	Enter 10 digit phone number. (No dashes or extensions) Example: 8668398477	503-267-0165
24	Company Website	Company Website (Format - www.company.com)	www.fieldturf.com
25	Federal ID Number:	Federal ID Number also known as the Employer Identification Number. (Format - 12-3456789)	58-2330410
26	Primary Address	Primary Address	175 N Industrial Blvd NE
27	Primary Address City	Primary Address City	Calhoun
28	Primary Address State	Primary Address State (2 Digit Abbreviation)	GA
29	Primary Address Zip	Primary Address Zip	30701
30	Search Words:	Please list search words to be posted in the TIPS database about your company that TIPS website users might search. Words may be product names, manufacturers, or other words associated with the category of award. YOU MAY NOT LIST NON-CATEGORY ITEMS. (Limit 500 words) (Format: product, paper, construction, manufacturer name, etc.)	FieldTurf, Beynon, Field, Turf, Track, Tennis, Grass, Synthetic, Football, Soccer, Baseball, Lacrosse, Court
31	Yes - No	Do you wish to be eligible to participate in a TIPS contract in which a TIPS member utilizes federal funds on contracts exceeding \$100,000? (Non-Construction)	Yes
32	Yes - No	Certification of Residency (Required by the State of Texas) Company submitting bid is a Texas resident bidder?	No
33	Company Residence (City)	Vendor's principal place of business is in the city of?	Cahloun
34	Company Residence (State)	Vendor's principal place of business is in the state of?	Georgia
35	Pricing Information:	Pricing information section. (Questions 36 - 38)	(No Response Required)
36	Yes - No	Pricing submitted includes the TIPS administration fee?	Yes
37	Yes - No	Vendor agrees to remit to TIPS the required administration fee?	Yes
38	Yes - No	Additional discounts to TIPS members for bulk quantities or scope of work?	Yes
39	Years Experience	Company years experience in this category?	21
40	Prices are guaranteed for?	(__Month(s), __ Year(s), or Term of Contract) (Standard term is "Term of Contract")	Term of Contract
41	Estimating Requirements	Awarded contractor must use Cost Works, JOC Works, RS Means Online, 4 Clicks, or Other Approved estimating software. If the contractor selects "Other Software", please make the request for approval in the next attribute question.	RS Means Online

- 42 Other Estimating Software Please list the program name, website address and phone number of the requested estimating software.
- 43 NON-COLLUSIVE BIDDING CERTIFICATE By submission of this bid or proposal, the Bidder certifies (No Response Required) that:
- 1) This bid or proposal has been independently arrived at without collusion with any other Bidder or with any Competitor;
 - 2) This bid or proposal has not been knowingly disclosed and will not be knowingly disclosed, prior to the opening of bids, or proposals for this project, to any other Bidder, Competitor or potential competitor;
 - 3) No attempt has been or will be made to induce any other person, partnership or corporation to submit or not to submit a bid or proposal;
 - 4) The person signing this bid or proposal certifies that he has fully informed himself regarding the accuracy of the statements contained in this certification, and under the penalties being applicable to the Bidder as well as to the person signing in its behalf. Not a negotiable term. Failure to agree will render your proposal non-responsive and it will not be considered.
- 44 CONFLICT OF INTEREST QUESTIONNAIRE - FORM CIQ If you have a conflict of interest as described in this form or the Local Government Code Chapter 176, cited therein- you are required to complete and file with TIPS, Richard Powell, 4845 US Highway 271 North, Pittsburg, Texas 75686 No
- You may find the Blank CIQ form on our website at:
- Copy and Paste the following link into a new browser or tab:
<https://www.tips-usa.com/assets/documents/docs/CIQ.pdf>
- Do you have any conflicts under this statutory requirement?
- 45 Filing of Form CIQ If yes (above), have you filed a form CIQ as directed here?

46 Certification Regarding Lobbying

Applicable to Grants, Subgrants, Cooperative Agreements, and Contracts Exceeding \$100,000 in Federal Funds. Yes, I certify
Submission of this certification is a prerequisite for making or entering into this transaction and is imposed by section 1352, Title 31, U.S. Code. This certification is a material representation of fact upon which reliance was placed when this transaction was made or entered into. Any person who fails to file the required certification shall be subject to a civil penalty of not less than \$10,000 and not more than \$100,000 for each such failure. The undersigned certifies, to the best of his or her knowledge and belief, that:
(1) No Federal appropriated funds have been paid or will be paid by or on behalf of the undersigned, to any person for influencing or attempting to influence an officer or employee of any agency, a Member of Congress, an officer or employee of congress, or an employee of a Member of Congress in connection with the awarding of a Federal contract, the making of a Federal grant, the making of a Federal loan, the entering into a cooperative agreement, and the extension, continuation, renewal, amendment, or modification of a Federal contract, grant, loan, or cooperative agreement.
(2) If any funds other than Federal appropriated funds have been paid or will be paid to any person for influencing or attempting to influence an officer or employee of any agency, a Member of Congress, an officer or employee of congress, or an employee of a Member of Congress in connection with this Federal grant or cooperative agreement, the undersigned shall complete and submit Standard Form-LLL, "disclosure Form to Report Lobbying," in accordance with its instructions.
(3) The undersigned shall require that the language of this certification be included in the award documents for all covered subawards exceeding \$100,000 in Federal funds at all appropriate tiers and that all subrecipients shall certify and disclose accordingly.

You may find the Blank Certification Regarding Lobbying form on our website at:

Copy and Paste the following link into a new browser or tab:

<https://www.tips-usa.com/assets/documents/docs/CRL.pdf>

Do you certify the three (3) certification of lobbying statements above? If you do not certify the three (3) statements above please download the Certification Regarding Lobbying form, fill out the form, sign the form, scan the form and upload to the Certification Regarding Lobbying section on the "Response Attachments" tab.

47 Regulatory Standing

I certify to TIPS for the proposal attached that my company is in good standing with all governmental agencies Federal or state that regulate any part of our business operations. If not, please explain in the next attribute question. Yes

48 Regulatory Standing

Regulatory Standing explanation of no answer. N/A

49 Antitrust Certification Statements (Tex. Government Code § 2155.005)

By submission of this bid or proposal, the Bidder certifies that: (No Response Required)

I affirm under penalty of perjury of the laws of the State of Texas that:

(1) I am duly authorized to execute this contract on my own behalf or on behalf of the company, corporation, firm, partnership or individual (Company) listed below;

(2) In connection with this bid, neither I nor any representative of the Company has violated any provision of the Texas Free Enterprise and Antitrust Act, Tex. Bus. & Comm. Code Chapter 15;

(3) In connection with this bid, neither I nor any representative of the Company has violated any federal antitrust law;

(4) Neither I nor any representative of the Company has directly or indirectly communicated any of the contents of this bid to a competitor of the Company or any other company, corporation, firm, partnership or individual engaged in the same line of business as the Company.

Instructions for Certification:

(No Response Required)

1. By agreeing to the form, the prospective lower tier participant is providing the certification set out on the form in accordance with these instructions.
2. The certification in this clause is a material representation of fact upon which reliance was placed when this transaction was entered into. If it is later determined that the prospective lower tier participant knowingly rendered an erroneous certification in addition to other remedies available to the federal government, the department or agency with which this transaction originated may pursue available remedies, including suspension and / or debarment.
3. The prospective lower tier participant shall provide immediate written notice to the person to which this proposal is submitted if at any time the prospective lower tier participant learns that its certification was erroneous when submitted or has become erroneous by reason of changed circumstances.
4. The terms "covered transaction," "debarred," "suspended," "ineligible," "lower tier covered transaction," "participants," "person," "primary covered transaction," "principal," "proposal" and "voluntarily excluded," as used in this clause, have the meanings set out in the Definitions and Coverage sections of rules implementing Executive Order 12549. You may contact the person to which this proposal is submitted for assistance in obtaining a copy of those regulations.
5. The prospective lower tier participant agrees by submitting this form that, should the proposed covered transaction be entered into, it shall not knowingly enter into any lower tier covered transaction with a person who is debarred, suspended, declared ineligible or voluntarily excluded from participation in this covered transaction, unless authorized by the department or agency with which this transaction originated.
6. The prospective lower tier participant further agrees by submitting this form that it will include this clause titled "Certification Regarding Debarment, Suspension, Ineligibility and Voluntary Exclusion-Lower Tier Covered Transaction" without modification in all lower tier covered transactions and in all solicitations for lower tier covered transactions.
7. A participant in a covered transaction may rely upon a certification of a prospective participant in a lower tier covered transaction that it is not debarred, suspended, ineligible or voluntarily excluded from the covered transaction, unless it knows that the certification is erroneous. A participant may decide the method and frequency by which it determines the eligibility of its principals. Each participant may, but is not required to, check the Nonprocurement List.
8. Nothing contained in the foregoing shall be construed to require establishment of a system of records in order to render in good faith the certification required by this clause. The knowledge and information of a participant is not required to exceed that which is normally possessed by a prudent person in the ordinary course of business dealings.
9. Except for transactions authorized under paragraph 5 of these instructions, if a participant in a covered transaction knowingly enters into a lower tier covered transaction with a person who is suspended, debarred, ineligible or voluntarily excluded from participation in this transaction, in addition to other remedies available to the federal government, the department or agency with which this transaction originated may pursue available remedies,

including suspension and / or debarment.

- 51 Suspension or Debarment Certification Debarment and Suspension (Executive Orders 12549 and 12689)—A contract award (see 2 CFR 180.220) must not be made to parties listed on the governmentwide exclusions in the System for Award Management (SAM), in accordance with the OMB guidelines at 2 CFR 180 that implement Executive Orders 12549 (3 CFR part 1986 Comp., p. 189) and 12689 (3 CFR part 1989 Comp., p. 235), "Debarment and Suspension." SAM Exclusions contains the names of parties debarred, suspended, or otherwise excluded by agencies, as well as parties declared ineligible under statutory or regulatory authority other than Executive Order 12549. Yes

By submitting this offer and certifying this section, this bidder:
Certifies that no suspension or disbarment is in place, which would preclude receiving a federally funded contract as described above.

- 52 Non-Discrimination Statement and Certification In accordance with Federal civil rights law and U.S. Department of Agriculture (USDA) civil rights regulations and policies, the USDA, its Agencies, offices, and employees, and institutions participating in or administering USDA programs are prohibited from discriminating based on race, color, national origin, religion, sex, gender identity (including gender expression), sexual orientation, disability, age, marital status, family/parental status, income derived from a public assistance program, political beliefs, or reprisal or retaliation for prior civil rights activity, in any program or activity conducted or funded by USDA (not all bases apply to all programs). Remedies and complaint filing deadlines vary by program or incident. Yes

Persons with disabilities who require alternative means of communication for program information (e.g., Braille, large print, audiotope, American Sign Language, etc.) should contact the responsible Agency or USDA's TARGET Center at (202) 720-2600 (voice and TTY) or contact USDA through the Federal Relay Service at (800) 877-8339. Additionally, program information may be made available in languages other than English.
To file a program discrimination complaint, complete the USDA Program Discrimination Complaint Form, AD-3027, found online at How to File a Program Discrimination Complaint and at any USDA office or write a letter addressed to USDA and provide in the letter all of the information requested in the form. To request a copy of the complaint form, call (866) 632-9992. Submit your completed form or letter to USDA by: (1) mail: U.S. Department of Agriculture, Office of the Assistant Secretary for Civil Rights, 1400 Independence Avenue, SW, Washington, D.C. 20250-9410; (2) fax: (202) 690-7442; or (3) email: program.intake@usda.gov.
(Title VI of the Education Amendments of 1972; Section 504 of the Rehabilitation Act of 1973; the Age Discrimination Act of 1975; Title 7 CFR Parts 15, 15a, and 15b; the Americans with Disabilities Act; and FNS Instruction 113-1, Civil Rights Compliance and Enforcement – Nutrition Programs and Activities)
USDA is an equal opportunity provider, employer, and lender.

Not a negotiable term. Failure to agree will render your proposal non-responsive and it will not be considered. I

certify that in the performance of a contract with TIPS or its members, that our company will conform to the foregoing anti-discrimination statement and comply with the cited law and regulations.

- 53 2 CFR PART 200 Contract Provisions Explanation (No Response Required)
- Required Federal contract provisions of Federal Regulations for Contracts for contracts with ESC Region 8 and TIPS Members:
- The following provisions are required to be in place and agreed if the procurement is funded in any part with federal funds.
- The ESC Region 8 and TIPS Members is the subgrantee or Subrecipient by definition. The federal Rule numbering or identification below is only for reference purpose on this form and does not identify an actual Federal designation or location of the rule. The Rules are located in 2 CFR PART 200 - Appendix II to Part 200—Contract Provisions for Non-Federal Entity Contracts Under Federal Awards at 2 CFR PART 200.
- In addition to other provisions required by the Federal agency or non-Federal entity, all contracts made by the non-Federal entity under the Federal award must contain provisions covering the following, as applicable.
- 54 2 CFR PART 200 (A) Contracts Yes
- Contracts for more than the simplified acquisition threshold currently set at \$150,000, which is the inflation adjusted amount determined by the Civilian Agency Acquisition Council and the Defense Acquisition Regulations Council (Councils) as authorized by 41 U.S.C. 1908, must address administrative, contractual, or legal remedies in instances where contractors violate or breach contract terms, and provide for such sanctions and penalties as appropriate. Notice: Pursuant to Federal Rule (A) above, when federal funds are expended by ESC Region 8 and TIPS Members, ESC Region 8 and TIPS Members reserves all rights and privileges under the applicable laws and regulations with respect to this procurement in the event of breach of contract by either party.
- Does vendor agree?
- 55 2 CFR PART 200 (B) Termination Yes
- Termination for cause and for convenience by the grantee or subgrantee including the manner by which it will be effected and the basis for settlement. (All contracts in excess of \$10,000)
- Pursuant to Federal Rule (B) above, when federal funds are expended by ESC Region 8 and TIPS Members, ESC Region 8 and TIPS Members reserves the right to terminate any agreement in excess of \$10,000 resulting from this procurement process for cause after giving the vendor an appropriate opportunity and up to 30 days, to cure the causal breach of terms and conditions. ESC Region 8 and TIPS Members reserves the right to terminate any agreement in excess of \$10,000 resulting from this procurement process for convenience with 30 days notice in writing to the awarded vendor. The vendor would be compensated for work performed and goods procured as of the termination date if for convenience of the ESC Region 8 and TIPS Members. Any award under this procurement process is not exclusive and the ESC Region 8 and TIPS reserves the right to purchase goods and services from other vendors when it is in the best interest of the ESC Region 8 and TIPS.
- Does vendor agree?

56	2 CFR PART 200 (G) Clean Air Act	<p>Clean Air Act (42 U.S.C. 7401-7671q.) and the Federal Water Pollution Control Act (33 U.S.C. 1251-1387), as amended—Contracts and subgrants of amounts in excess of \$150,000 must contain a provision that requires the non-Federal award to agree to comply with all applicable standards, orders or regulations issued pursuant to the Clean Air Act (42 U.S.C. 7401-7671q) and the Federal Water Pollution Control Act as amended (33 U.S.C. 1251-1387). Violations must be reported to the Federal awarding agency and the Regional Office of the Environmental Protection Agency (EPA).</p> <p>Pursuant to Federal Rule (G) above, when federal funds are expended by ESC Region 8 and TIPS Members, ESC Region 8 and TIPS Members requires that the proposer certify that during the term of an award by the ESC Region 8 and TIPS Members resulting from this procurement process the vendor agrees to the terms listed and referenced therein.</p> <p>Does vendor agree?</p>	Yes
57	2 CFR PART 200 (H) Debarment and Suspension	<p>Debarment and Suspension (Executive Orders 12549 and 12689)—A contract award (see 2 CFR 180.220) must not be made to parties listed on the governmentwide exclusions in the System for Award Management (SAM), in accordance with the OMB guidelines at 2 CFR 180 that implement Executive Orders 12549 (3 CFR part 1986 Comp., p. 189) and 12689 (3 CFR part 1989 Comp., p. 235), "Debarment and Suspension." SAM Exclusions contains the names of parties debarred, suspended, or otherwise excluded by agencies, as well as parties declared ineligible under statutory or regulatory authority other than Executive Order 12549.</p> <p>Pursuant to Federal Rule (H) above, when federal funds are expended by ESC Region 8 and TIPS Members, ESC Region 8 and TIPS Members requires the proposer certify that during the term of an award by the ESC Region 8 and TIPS Members resulting for this procurement process the vendor certifies that they are not debarred from receiving a contract from the federal government as provided therein.</p> <p>Does vendor agree?</p>	Yes
58	2 CFR PART 200 (I) Byrd Anti-Lobbying Amendment	<p>Byrd Anti-Lobbying Amendment (31 U.S.C. 1352)—Contractors that apply or bid for an award exceeding \$100,000 must file the required certification. Each tier certifies to the tier above that it will not and has not used Federal appropriated funds to pay any person or organization for influencing or attempting to influence an officer or employee of any agency, a member of Congress, officer or employee of Congress, or an employee of a member of Congress in connection with obtaining any Federal contract, grant or any other award covered by 31 U.S.C. 1352. Each tier must also disclose any lobbying with non-Federal funds that takes place in connection with obtaining any Federal award. Such disclosures are forwarded from tier to tier up to the non-Federal award.</p> <p>Pursuant to Federal Rule (I) above, when federal funds are expended by ESC Region 8 and TIPS Members, ESC Region 8 and TIPS Members requires the proposer certify that during the term and after the awarded term of an award by the ESC Region 8 and TIPS Members resulting for this procurement process the vendor certifies to the terms included or referenced therein.</p> <p>Does vendor agree?</p>	Yes

59	2 CFR PART 200 Federal Rule (12)	<p>Federal Rule (12) Compliance with all applicable standards, orders, or requirements issued under section 306 of the Clean Air Act (42 U.S.C. 1857(h)), section 508 of the Clean Water Act (33 U.S.C. 1368), Executive Order 11738, and Environmental Protection Agency regulations (40 CFR part 15). (Contracts, subcontracts, and subgrants of amounts in excess of \$100,000)</p> <p>Pursuant to Federal Rule (12) above, when federal funds are expended by ESC Region 8 and TIPS Members, ESC Region 8 and TIPS Members requires the proposer certify that in performance of the contracts, subcontracts, and subgrants of amounts in excess of \$100,000, the vendor will be in compliance with all applicable standards, orders, or requirements issued under section 306 of the Clean Air Act (42 U.S.C. 1857(h)), section 508 of the Clean Water Act (33 U.S.C. 1368), Executive Order 11738, and Environmental Protection Agency regulations (40 CFR part 15).</p> <p>Does vendor certify that it is in compliance with the Clean Air Act?</p>	Yes
60	2 CFR PART 200 Procurement of Recovered Materials	<p>A non-Federal entity that is a state agency or agency of a political subdivision of a state and its contractors must comply with section 6002 of the Solid Waste Disposal Act, as amended by the Resource Conservation and Recovery Act. The requirements of Section 6002 include procuring only items designated in guidelines of the Environmental Protection Agency (EPA) at 40 CFR part 247 that contain the highest percentage of recovered materials practicable, consistent with</p> <p>maintaining a satisfactory level of competition, where the purchase price of the item exceeds \$10,000 or the value of the quantity acquired during the preceding fiscal year exceeded \$10,000; procuring solid waste management services in a manner that maximizes energy and resource recovery; and establishing an affirmative procurement program for procurement of recovered materials identified in the EPA guidelines.</p> <p>Does vendor certify that it is in compliance with the Solid Waste Disposal Act as described above?</p>	Yes

61 Indemnification

The ESC Region 8 and TIPS is a Texas Political Subdivision and a local governmental entity; therefore, is prohibited from indemnifying third parties pursuant to the Texas Constitution (Article 3, Section 52) except as specifically provided by law or as ordered by a court of competent jurisdiction. A provision in a contract to indemnify or hold a party harmless is a promise to pay for any expenses the indemnified party incurs, if a specified event occurs, such as breaching the terms of the contract or negligently performing duties under the contract. Article III, Section 49 of the Texas Constitution states that "no debt shall be created by or on behalf of the State ... " The Attorney General has counseled that a contractually imposed obligation of indemnity creates a "debt" in the constitutional sense. Tex. Att'y Gen. Op. No. MW-475 (1982). Contract clauses which require the System or institutions to indemnify must be deleted or qualified with "to the extent permitted by the Constitution and Laws of the State of Texas." Liquidated damages, attorney's fees, waiver of vendor's liability, and waiver of statutes of limitations clauses should also be deleted or qualified with "to the extent permitted by the Constitution and laws of State of Texas." Not a negotiable term. Failure to agree will render your proposal non-responsive and it will not be considered. Do you agree to these terms?

Yes

62 Remedies

The parties shall be entitled to exercise any right or remedy available to it either at law or in equity, subject to the choice of law, venue and service of process clauses limitations agreed herein. Nothing in this agreement shall commit the TIPS to an arbitration resolution of any disagreement under any circumstances. Any Claim arising out of or related to the Contract, except for those specifically waived under the terms of the Contract, may, after denial of the Board of Directors, be subject to mediation at the request of either party. Any issues not resolved hereunder must be referred to non-binding mediation to be conducted by a mutually agreed upon mediator as a prerequisite to the filing of any lawsuit over such issue(s). The parties shall share the mediator's fee and any associated filing fee equally. Mediation shall be held in Camp or Titus County, Texas. Agreements reached in mediation shall be reduced to writing, and will be subject to the approval by the District's Board of Directors, signed by the Parties if approved by the Board of Directors, and, if signed, shall thereafter be enforceable as provided by the laws of the State of Texas. Do you agree to these terms?

Yes, I Agree

63 Remedies Explanation of No Answer

64	Choice of Law	<p>This agreement and any addenda or other additions and all contracts or awards resulting from this procurement process, however described, shall be governed by, construed and enforced in accordance with the laws of the State of Texas, regardless of any conflict of laws principles.</p> <p>Not a negotiable term. Failure to agree will render your proposal non-responsive and it will not be considered. Do you agree to these terms?</p>	Yes
65	Jurisdiction and Service of Process	<p>Any Proceeding arising out of or relating to this procurement process or any contract issued by TIPS resulting from or any contemplated transaction shall be brought in a court of competent jurisdiction in Camp County, Texas and each of the parties irrevocably submits to the exclusive jurisdiction of said court in any such proceeding, waives any objection it may now or hereafter have to venue or to convenience of forum, agrees that all claims in respect of the Proceeding shall be heard and determined only in any such court, and agrees not to bring any proceeding arising out of or relating to this procurement process or any contract resulting from or any contemplated transaction in any other court. The parties agree that either or both of them may file a copy of this paragraph with any court as written evidence of the knowing, voluntary and freely bargained for agreement between the parties irrevocably to waive any objections to venue or to convenience of forum. Process in any Proceeding referred to in the first sentence of this Section may be served on any party anywhere in the world. Venue clauses in contracts with TIPS members may be determined by the parties.</p> <p>Not a negotiable term. Failure to agree will render your proposal non-responsive and it will not be considered. Do you agree to these terms?</p>	Yes
66	Alternative Dispute Resolution	<p>Prior to filing of litigation, the parties may select non-binding mediation as a method of conflict resolution for issues arising out of or relating to this procurement process or any contract resulting from or any contemplated transaction. The parties agree that if nonbinding mediation is chosen as a resolution process, the parties must agree to the chosen mediator(s) and that all mediation venue shall be at a location in Camp or Titus, County, Texas agreed by the parties. The parties agree to share equally the cost of the mediation process and venue cost.</p> <p>Do you agree to these terms?</p>	Yes, I Agree
67	Alternative Dispute Resolution Explanation of No Answer		N/A
68	Infringement(s)	<p>The successful vendor will be expected to indemnify and hold harmless the TIPS and its employees, officers, agents, representatives, contractors, assignees and designees from any and all third party claims and judgments involving infringement of patent, copyright, trade secrets, trade or service marks, and any other intellectual or intangible property rights in connection with the vendor's proposal or ultimate contracts awarded and approved.</p>	Yes, I Agree

Do you agree to these terms?

69	Infringement(s) Explanation of No Answer		N/A
70	Acts or Omissions	The successful vendor will be expected to indemnify and hold harmless the TIPS, its officers, employees, agents, representatives, contractors, assignees and designees from and against any and all liability, actions, claims, demands or suits, and all related costs, attorney's fees and expenses arising out of, or resulting from any acts or omissions of the vendor or its agents, employees, subcontractors, or suppliers in the execution or performance of any agreements ultimately made by TIPS and the vendor. Do you agree to these terms?	Yes, I Agree
71	Acts or Omissions Explanation of No Answer		N/A
72	Contract Governance	Any contract made or entered into by the TIPS is subject to and is to be governed by Section 271.151 et seq, Tex Loc Gov't Code. Otherwise, TIPS does not waive its governmental immunities from suit or liability except to the extent expressly waived by other applicable laws in clear and unambiguous language.	Yes
73	Payment Terms and Funding Out Clause	Payment Terms: TIPS members pay net 30 or at point of sale and complies with the State of Texas payment law, Texas Government Code, Chapter 2251. See statute for specifics or consult your legal counsel. These are minimum terms required of the TIPS member in Texas by law and the parties may negotiate custom payment terms as desired provided they do not violate the statutory requirements. Statutory or binding regulations control TIPS members in this contract. Funding out Clause: Pursuant to Texas Local Government Code Sec. 271.903, any proposal offer accepted by TIPS and its members and all contracts to be approved are subject to the budgeting and appropriation of then currently available funds. See statute for specifics or consult your legal counsel. Not a negotiable term. Failure to agree will render your proposal non-responsive and it will not be considered. Do you agree to these terms?	Yes

74 Insurance and Fingerprint Requirements Information

Insurance

If applicable and your staff will be on TIPS member premises for delivery, training or installation etc. and/or with an automobile, you must carry automobile insurance as required by law. You may be asked to provide proof of insurance.

Fingerprint

It is possible that a vendor may be subject to Chapter 22 of the Texas Education Code. The Texas Education Code, Chapter 22, Section 22.0834. Statutory language may be found at: <http://www.statutes.legis.state.tx.us/>

If the vendor has staff that meet both of these criterion:
(1) will have continuing duties related to the contracted services; and

(2) has or will have direct contact with students

Then you have "covered" employees for purposes of completing the attached form.

TIPS recommends all vendors consult their legal counsel for guidance in compliance with this law. If you have questions on how to comply, see below. If you have questions on compliance with this code section, contact the Texas Department of Public Safety Non-Criminal Justice Unit, Access and Dissemination Bureau, FAST-FACT at

NCJU@txdps.state.tx.us and you should send an email identifying you as a contractor to a Texas Independent School District or ESC Region 8 and TIPS. Texas DPS phone number is (512) 424-2474.

See form in the next attribute to complete entitled:

Texas Education Code Chapter 22 Contractor Certification for Contractor Employees

(No Response Required)

75 Texas Education Code Chapter 22 Contractor Certification for Contractor Employees

Introduction: Texas Education Code Chapter 22 requires entities that contract with school districts to provide services to obtain criminal history record information regarding covered employees. Contractors must certify to the district that they have complied. Covered employees with disqualifying criminal histories are prohibited from serving at a school district.

Definitions: Covered employees: Employees of a contractor or subcontractor who have or will have continuing duties related to the service to be performed at the District and have or will have direct contact with students. The District will be the final arbiter of what constitutes direct contact with students. Disqualifying criminal history: Any conviction or other criminal history information designated by the District, or one of the following offenses, if at the time of the offense, the victim was under 18 or enrolled in a public school:

(a) a felony offense under Title 5, Texas Penal Code; (b) an offense for which a defendant is required to register as a sex offender under Chapter 62, Texas Code of Criminal Procedure; or (c) an equivalent offense under federal law or the laws of another state.

I certify that:

NONE (Section A) of the employees of Contractor and any subcontractors are covered employees, as defined above. If this box is checked, I further certify that Contractor has taken precautions or imposed conditions to ensure that the employees of Contractor and any subcontractor will not become covered employees. Contractor will maintain these precautions or conditions throughout the time the contracted services are provided.

OR

SOME (Section B) or all of the employees of Contractor and any subcontractor are covered employees. If this box is checked, I further certify that:

(1) Contractor has obtained all required criminal history record information regarding its covered employees. None of the covered employees has a disqualifying criminal history.

(2) If Contractor receives information that a covered employee subsequently has a reported criminal history, Contractor will immediately remove the covered employee from contract duties and notify the District in writing within 3 business days.

(3) Upon request, Contractor will provide the District with the name and any other requested information of covered employees so that the District may obtain criminal history record information on the covered employees.

(4) If the District objects to the assignment of a covered employee on the basis of the covered employee's criminal history record information, Contractor agrees to discontinue using that covered employee to provide services at the District.

Noncompliance or misrepresentation regarding this certification may be grounds for contract termination.

76 Solicitation Deviation/Compliance

Does the vendor agree with the General Conditions Standard Terms and Conditions or Item Specifications listed in this proposal invitation? Yes

77 Solicitation Exceptions/Deviations Explanation	<p>If the bidder intends to deviate from the General Conditions Standard Terms and Conditions or Item Specifications listed in this proposal invitation, all such deviations must be listed on this attribute, with complete and detailed conditions and information included or attached.</p> <p>TIPS will consider any deviations in its proposal award decisions, and TIPS reserves the right to accept or reject any bid based upon any deviations indicated below or in any attachments or inclusions.</p> <p>In the absence of any deviation entry on this attribute, the proposer assures TIPS of their full compliance with the Standard Terms and Conditions, Item Specifications, and all other information contained in this Solicitation.</p>	N/A
78 Agreement Deviation/Compliance	Does the vendor agree with the language in the Vendor Agreement?	Yes
79 Agreement Exceptions/Deviations Explanation	<p>If the proposing Vendor desires to deviate from the Vendor Agreement language, all such deviations must be listed on this attribute, with complete and detailed conditions and information included. TIPS will consider any deviations in its proposal award decisions, and TIPS reserves the right to accept or reject any proposal based upon any deviations indicated below. In the absence of any deviation entry on this attribute, the proposer assures TIPS of their full compliance with the Vendor Agreement.</p>	N/A

Line Items

Response Total: \$0.00

REFERENCES

Please provide three (3) references, preferably from school districts or other governmental entities who have used your services within the last three years. Additional references may be required. DO NOT INCLUDE TIPS EMPLOYEES AS A REFERENCE.

You may provide more than three (3) references.

Entity Name	Contact Person	Email	Phone
Mesquite ISD (6 Fields) (Texas)	Steve Bragg-Athletic Director	sbragg@mesquiteisd.org	972-882-7380
Celina ISD (2 fields) (Texas)	Bill Elliott-Athletic Director	billelliott@celinaisd.com	469-742-9120
Aledo ISD (Texas)	Tim Buchanan-Athletic Director	tbuchanan@aledo.k12.tx.us	817-235-5548
Clarksville Public Schools (Arkansas)	Toby Cook-Asst Superintendent	Toby.Cook@csdar.org	479-214-0911
Greenwood Public Schools (Arkansas)	John Ciesla-Superintendent	john.ciesla@greenwoodk12.com	479-996-4142
Batesville Public Schools (Arkansas)	Frank Drye-Facilities Director	frank.drye@batesvilleschools.org	870-793-0615
University of Central Oklahoma	Joe Muller-Director of Athletics	jmuller2@uco.edu	405-974-2502
Ardmore Public Schools (Oklahoma)	Chris Kennedy-Facilities Director	ckennedy@ardmoreschools.org	580-220-5925
Cushing Public School (Oklahoma)	Koln Knight-Superintendent	koln.knight@cushing.k12.ok.us	918-225-3425
Amarillo ISD (Texas)	Brad Thiessen-Director of Athletics	brad.thiessen@amaisd.org	806-584-1871
University of Texas Permian Basin	Steve Aicinena-Director of Athletics	aicinena_s@utpb.edu	432-552-2675

Please see full installation list for nationwide references



THE STAGE OF SPORTS EVOLUTION



Why Artificial Turf is the SMART OPTION



Increased field usage for the life of the surface

Creates significant new revenue stream from field rentals

Greatly reduces the overall costs of field maintenance

Saves billions of gallons of clean water each year

Eliminates the use of billions of pounds of chemicals each year

Diverts millions of tires from landfill sites each year

Eliminates grass clippings and fuel-powered mowing, aerating and re-seeding

Provides the opportunity to obtain multiple LEED credits

Here's what independent reviews often find when comparing Natural Grass and Artificial Turf fields:

“Despite the higher up-front and future replacement costs, an artificial turf MCPS Stadium field provides a substantially lower net cost per hour of use than any of the natural grass options because of the substantially increased hours of use and additional revenue generated from that increased use.”
Montgomery County Work Group

20 Year Cost Summary						
	Artificial Turf	Bermuda (Sand Base)	Kentucky BG (Sand Base)	Bermuda (Native Soil)	Cool Season (Native Soil)	
20 Year Net Costs	Initial Capital Cost	1,125,000	530,000	580,000	150,000	75,000
	20 Year Replacement Cost*	1,280,000	150,000	175,000	100,000	60,000
	20 Year Maintenance / Other Costs	206,000	1,000,000	1,000,000	900,000	500,000
	20 Year Total Costs	2,611,000	1,680,000	1,755,000	1,150,000	635,000
	20 Year Revenue - MCPS**	1,600,000	-	-	-	-
	20 Year Net Cost - MCPS	1,011,000	1,680,000	1,755,000	1,150,000	635,000
Cost Per Hour of Use	Annual Hours of Use	2,300	600	500	400	300
	20 Year Net Cost Per Hour of Use - MCPS	21.98	140.00	175.50	143.75	105.83

You know artificial turf makes sense.
So...what now?
 Time to find the right **turf partner.**

*Assumes two artificial turf carpet replacements (after years 8 and 16) and one major natural grass rehab after year 12.
 **No revenue assumed for natural grass fields since MCPS would reserve these fields only for MCPS team games and practices.

WHY FIELDTURF IS THE RIGHT TURF PARTNER

Since our invention of the original long pile artificial turf system some 15 years ago, we've been consistently innovating the industry.

Today, we don't just make turf. We make a difference.

Our dedication to innovation helps us make a difference for athletes, facility owners and operators – every single day.

PROVEN SAFETY

We've invested in key partnerships to study the issues that matter – like how compared to natural grass, FieldTurf can help reduce concussions and lower body injuries.

5 Year High School Football Study

- 44% Fewer Concussion Injuries Combined
- 43% Fewer ACL Injuries Combined
- 34% Fewer Ligament Tears
- 25% Fewer Injuries (Lasting 22+ Days)
- 20% Fewer 3rd Degree Injuries
- 16% Fewer Injuries (Lasting 1-2 Days)

Source: American Journal of Sports Medicine
HIGH SCHOOL FOOTBALL SAFETY STUDY: FIELDTURF VS. NATURAL GRASS, A 5-YEAR PROSPECTIVE STUDY

3 Year College Football Study

- 24% Fewer High Ankle Sprains
- 23% Fewer Injuries on 4-8+ Year Old Surface
- 20% Fewer Muscle Strains / Tears
- 20% Fewer Ligament Tears
- 20% Fewer Severe Injuries
- 12% Fewer Concussions

Source: American Journal of Sports Medicine
COLLEGE FOOTBALL SAFETY STUDY: FIELDTURF VS. NATURAL GRASS, A 3-YEAR PROSPECTIVE STUDY

SUPERIOR PERFORMANCE

Not only do our systems mirror the look and feel of natural grass – they replicate its performance! When compared to competitive turf systems, FieldTurf showcases superior performance.

Rotational traction values for each surface

Surface	Rotational Traction (Nm)
FieldTurf Revolution	53.1
Kentucky Bluegrass	52.3

See study for full results.

Source: The Pennsylvania State University
COMPARISON OF ROTATIONAL TRACTION OF ATHLETIC FOOTWEAR ON VARYING PLAYING SURFACES USING DIFFERENT NORMAL LOADS

GLOBAL EXPERIENCE

With over 5000 installations in North America and 7500 worldwide, FieldTurf has been the surface of choice for the last 20+ years.

Association	Number of Fields
NFL	20
FIFA 1 / 2 Star	211
NCAA Div I	500+

UNMATCHED DURABILITY

Manufactured and installed with the highest attention to detail, FieldTurf turf systems showcase proven durability. There are over 5000 FieldTurf fields still in use that are 8 or more years old.

Years of Use	Number of Fields
10+	1450
9+	1865
8+	2387

ENDLESS INNOVATION

From the original 3 layer infill system; to our SureLock coating drainage system; to our game-changing CoolPlay system – our patented innovations continue to change the game.

HONESTLY GREEN

Being green is not a cliché for us. It's a reality. Each year we help save millions of gallons of fresh water and eliminate tons of chemicals and pesticides. Our Cradle to Cradle™ certification is just part of our ongoing commitment to use recycled content in our manufacturing and convert old turf fields into new, reusable materials.

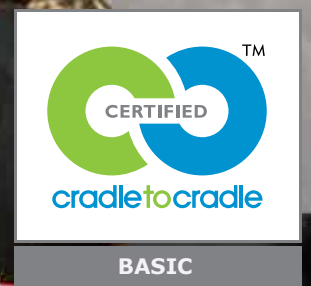
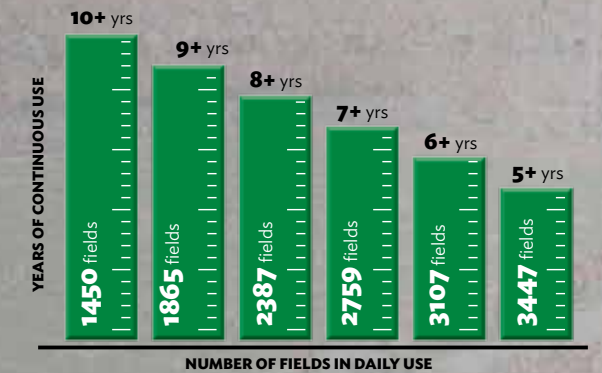
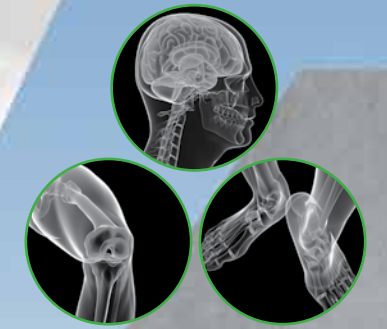

WE MAKE THE GAME SAFER

Heavyweight infill systems rise above.

Exhaustive study confirms that infill weight plays a key role in reducing player injuries.

Systems with >9.0 lbs/sq ft are proven safer!

Study presented at the 2014 annual American Orthopaedic Society for Sports Medicine (AOSSM) meeting. Percentage of Reduced Incidence of Injury on FieldTurf comparing FieldTurf with infill weight of >9 lbs/sq ft to other turf systems with 0 lbs to 5.9 lbs/sq ft of infill weight.



Concussion Injuries Combined
8.3%

lower incidence of injury between FieldTurf >9 lbs/sq ft and 3-5.9 lbs/sq ft



Total Injuries
20.5%

lower incidence of injury between FieldTurf >9 lbs/sq ft and 3-5.9 lbs/sq ft



Severe Injuries
16.8%

lower incidence of injury between FieldTurf >9 lbs/sq ft and 3-5.9 lbs/sq ft



Player-to-Turf Collisions
36.9%

lower incidence of injury between FieldTurf >9 lbs/sq ft and 3-5.9 lbs/sq ft



Adverse Weather Conditions Combined
26.3%

lower incidence of injury between FieldTurf >9 lbs/sq ft and 3-5.9 lbs/sq ft



Turf Age (4 to 8+ years)
33.8%

lower incidence of injury between FieldTurf >9 lbs/sq ft and 3-5.9 lbs/sq ft



Turf Age (8+ years)
72.7%

lower incidence of injury between FieldTurf >9 lbs/sq ft and 3-5.9 lbs/sq ft

MANUFACTURING EXCELLENCE



FIBER PRODUCTION:

Our fibers are produced at our very own facility in Germany, making FieldTurf one of the most vertically integrated companies in the world. The quality control process at our facility follows stringent testing of the yarn properties, including tensile strength, uniformity and color verification.



TUFTING EXPERTISE:

Once the fiber is produced it is ready for tufting. This takes place at our 500,000 square-foot manufacturing plant in Calhoun, Georgia. This plant is an ultra-modern facility in the heart of carpet country, with dedicated employees who have 300+ years of combined experience in the artificial turf industry.



COATING INNOVATION:

One of the most sophisticated coating lines in the artificial turf industry is at the heart of FieldTurf's Calhoun plant. It features our patented SureLock coating system which leaves 40% of the turf backing porous for industry-leading field drainage.



IN-HOUSE LOGO PRODUCTION:

Our specialized manufacturing capabilities allow us to bring your logo to life. Our logo experts can reproduce the most intricate and complex turf logos - and we do it all in-house. No matter the size, shape, color or detail of your logo, our team will reproduce it and bring it to life in your field.



EXPERIENCED INSTALLERS:

Installing a FieldTurf field is an art. Our installers are experienced and fully trained in all aspects of the FieldTurf product. These qualified experts are the ones our customers can count on to make sure that every FieldTurf field is installed to perform exactly as expected.

FieldTurf controls all aspects of the manufacturing value chain. This provides our customers with a high level of quality assurance.

WHICH SYSTEM IS RIGHT FOR YOU?

EACH OF OUR CUSTOMERS HAS UNIQUE NEEDS.

Our “Customer-First” philosophy guides YOU to identify the type of field YOU need.

And while many turf companies try to sell you “their best product” without ever knowing your needs, FieldTurf opts for a different approach. Our “Customer-First” philosophy guides you to identify the type of field you need. Our sports turf systems today are very different from anything else. Each is constructed with meticulous fiber and infill design criteria, to serve the unique needs of very different customers.

FIBER

SLIT-FILM

- Consists of wider fibers designed to lie over and encapsulate the infill, while absorbing heavy use from kicks, drags, tackles and slides
- Designed to withstand the highest use and provide durable, long-lasting fields



MONOFILAMENT

- Resilient individual monofilament fibers designed to stand upright
- Designed primarily for grass-like aesthetics and proper ball-roll characteristics; monofilament fibers give the field the desired appearance of perfectly mowed, healthy natural grass



HYBRID

- A combination of monofilament fibers and a slit-film fiber in the same stitch
- Designed to provide fiber resilience while encapsulating the infill for the life of the field



INFILL SYSTEMS

THREE-LAYER

- One of the most intricate and meticulous infill systems available today, this system can only be achieved by experienced installers
- Designed to provide the best Gmax and energy restitution results, providing athletes with improved safety and performance

AVAILABLE SYSTEMS

- REVOLUTION 360 • CLASSIC HD
- VERTEX PRIME



TWO-LAYER

- This homogeneous infill system consists of a sand base with crumb rubber to provide the proper firmness required for optimal athletic performance while providing proper shock absorption

AVAILABLE SYSTEMS

- XM6 • XT • VERTEX



LOW-INFILL

- Built on a pad, these systems utilize a basic design, re-engineered with new age technology to offer an alternative surface solution constructed with thatch and either little rubber or completely rubber-free

AVAILABLE SYSTEMS

- VINTAGE SERIES
- HOCKEY MULTI



GAUGE

Gauge refers to the distance between the rows of fibers. FieldTurf has the ability to produce a wide variety of gauges – but our standard systems are produced with a 3/4” gauge.

This wide gauge 3/4” spacing allows for proper cleat penetration of the infill. Proper penetration enables the athlete to plant, twist and release just like they do on natural grass – without undue torque transmitted to the knees and ankles. As a result, chances of injuries are greatly reduced.

Other turf systems typically use a very narrow gauge usually 3/8” or 1/2”. This narrow gauge results in turf that is overly dense, preventing the same penetration and positive biomechanical functions found on FieldTurf and natural grass.

The result is that the athlete plays on or in the fibers – not in the infill. This can cause the fibers to wear faster and makes it more difficult for the athlete to get solid footing, causing slippage.

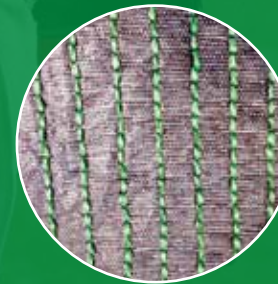

TURF BACKING

FINGER-UNIT / SURELOCK

- This backing delivers ultimate strength, stability and drainage
- A patented finger-unit seals only the rows of fibers, leaving the backing 40% porous, allowing for unmatched drainage.



SOLID COATED / PERFORATED

- While not quite as effective as the finger-unit backing, this backing provides good tuft bind and stability
- This solid coated backing is perforated to facilitate drainage

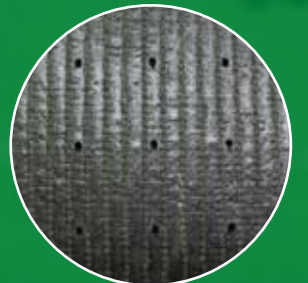

WHICH INFILL IS RIGHT FOR YOU?

The infill system is one of the most important aspects of all synthetic turf fields. It is the basis for the safety of the turf system by providing the appropriate cushioning to absorb impact. The infill provides the foundation to a field's performance level by offering traction for players to cut, plant and release just like they would on natural grass.

The infill is spread between the fibers to deliver what the athlete needs – a safe surface with proper performance attributes. The infill market is becoming more complex with new products being introduced at a rapid rate. With so many choices, it is important to understand the difference between the various infill types and materials.



Cryogenic Rubber

CRYOGENIC SBR

Cryogenic rubber is the cleanest and highest grade of recycled crumb rubber granule. Made from ground-up recycled tires, which have first been cryogenically frozen and then shattered, it provides a cleaner, smoother and rounded particle. It stays in suspension within a sand particle mix and is less likely to float in water.



Ambient Rubber

AMBIENT SBR

Ambient rubber is made from tires that are ground up at ambient temperatures. It results in a rougher and more irregular crumb than cryogenic rubber, with considerably more loose particulate. Its jagged edges attract water bubbles that can make it prone to flotation and displacement in wet conditions.



CoolPlay

COOLPLAY

CoolPlay utilizes FieldTurf's exclusive and innovative Extruded Cork Composite top dressing which allows the system to deliver the same behavior and overall stability as the elite systems but with an added heat reduction feature – up to 35° F cooler!



PureFill

PUREFILL

FieldTurf's PureFill cork infill is an all-natural infill. It is an organic, recyclable and sustainable product that is harvested from the cork oak tree every nine years, without harming the trees. It is 100% environmentally-friendly and non-toxic.



EcoMax

ECOMAX

EcoMax is an extruded composite of recycled materials and thermoplastic elastomer (TPE). It is a new, impact absorbing infill that offers safe and comfortable performance and the best value in its category regarding durability, price and performance.



EcoGreen

ECOGREEN

EcoGreen is built from premium, virgin TPE that have been selected for their characteristics to deliver a stable surface over the long-term. Each pellet has built-in memory and rebounds back to its original shape after compression. Resistant to UV degradation, it is a durable and fully recyclable infill alternative.



EcoGrind

ECOGRIND

EcoGrind is one of the most cost-efficient alternatives to SBR. Made from post-industrial recycled products, these reclaimed materials are ground-up to create a new, clean, eco-friendly infill and another alternative to crumb rubber. EcoGrind is the ideal answer for high use facilities looking for a proven infill solution.

PROVEN SAFE

Independent tests confirm that FieldTurf infill materials meet or exceed the stringent EN 71-3 requirements used in validating the safety of children's toys and materials.

WE ARE AS COMMITTED TO YOUR PROGRAM AS YOU ARE

And we're with you for the long term. When you buy a field from FieldTurf, you're buying from a company that knows how to take care of you. It's what we do best. We like to think of ourselves as the most trusted turf company. And every day that your athletes play on our turf, you will understand why.

CUSTOMER CONNECT

As a FieldTurf customer you will enjoy exclusive access to our online community, Customer Connect. You will appreciate this convenient service which offers users a full resource of maintenance content and an online store.



AFTERCARE SERVICE

FieldTurf's FieldCare Maintenance Program secures your investment by adding to your field's life, delivering consistent high performance and providing significant cost savings. We'll even build a customized program just for you.



INITIAL TRAINING

We'll make sure you know everything about your new FieldTurf field. After your field is installed, our experts will teach you exactly how to care for your new surface and keep it performing in top condition.

RESPONSE TIME

We pride ourselves on quick and effective response time. Our specially trained FieldTurf crews are always standing by. You'll never be stranded with a FieldTurf team that's here to handle any situation that may arise.



"The FieldTurf team has done a tremendous job at our school. We have 3 FieldTurf fields on our campus (2 outdoor and 1 indoor) and their commitment and responsiveness to our needs is second to none. They do what they promise in a timely manner and are always courteous and professional. We enjoy dealing with a company who puts our needs first."

Dan MacLean, Head Football Coach
Detroit Country Day School

"In the fall of 2013 we had Field Care come in and refurbish our football field. By the time they were done the field looked like new! I would recommend Field Care if you have any problems with your synthetic turf fields."

Erich Kiel, Facilities Coordinator
Eastern Michigan University





THE CHOICE OF FOOTBALL AT EVERY LEVEL

With fields at over 20 NFL teams, 150 premier NCAA programs and thousands of prestigious High Schools across the country, FieldTurf is the home of Football. Every year over 5 million snaps are taken on our surfaces. Trust FieldTurf's renowned performance, safety and quality.



"We went with FieldTurf because we wanted the best! Even after several years of use, it still looks and plays like new. We can see the difference our surface makes on the entire football team and directly affects our play and performance."

Steve Smith - Head Football Coach and Athletic Director, Piedmont High School

"...the biggest difference for me was our ability to stick our foot in the ground. FieldTurf really made a difference... we were able to really make some sharp cuts on that surface."

Brian Kelley - Head Coach, Notre Dame

"FieldTurf provides the best possible game and practice surfaces for our teams while maintaining the consistency and integrity of these high-use fields."

Jim Nolan, Sr. - Vice President of Finance, Administration and Operations for Gillette Stadium

20%



FEWER LIGAMENT TEARS

12%



LESS CONCUSSIONS

3 Year College Football Study
Source: COLLEGE FOOTBALL SAFETY STUDY:
FIELDTURF VS. NATURAL GRASS,
A 3-YEAR PROSPECTIVE STUDY
AMERICAN JOURNAL OF SPORTS MEDICINE



BEAUTIFUL TURF FOR THE BEAUTIFUL GAME



FC BARCELONA
OFFICIAL SPORTS SURFACES SUPPLIER



THE PITCH OF CHAMPIONS

FieldTurf is the choice of football around the globe. And it's the choice of top clubs like FC Barcelona, Ajax, Arsenal, Liverpool, West Ham United, Paris Saint Germain, Olympique Lyonnais, Werder Bremen, and Seattle Sounders.

Independent studies show that FieldTurf fiber technology delivers grass-like playability and ideal ball roll.

Our heavyweight infill system and wide gauge tufting allow us to achieve exceptional results for safety, energy restitution and performance.



Creighton University

Century Link Field

Gillette Stadium

SC Cambuur



[18]



[19]



University of Oregon

University of Houston

Brooklyn Cyclones

University of Texas

Oregon State University

University of Louisville

Dartmouth College

Sweeny High School

BASEBALL SOFTBALL

THE 5 PILLARS BEHIND FIELDTURF DOUBLEPLAY

SURFACE SPEED

Fast or grass-like, we customize surface speed to your program

NATURAL AESTHETICS

Unique fiber height for the most realistic appearance

REDUCED INFILL SPLASH

Documented infill splash reduction

INNOVATIVE DURABILITY SOLUTIONS

Tufted technologies for longer-lasting high-use areas

COACH APPROVED

We don't leave the site until Coach is satisfied!



"Man this stuff is good. I believe that playing on our FieldTurf field has helped in terms of getting our guys used to consistent play and focusing on making plays. It has been a contributor to our success and has helped Oregon State Baseball strive to reach the next level."
Pat Casey, Oregon State Beavers

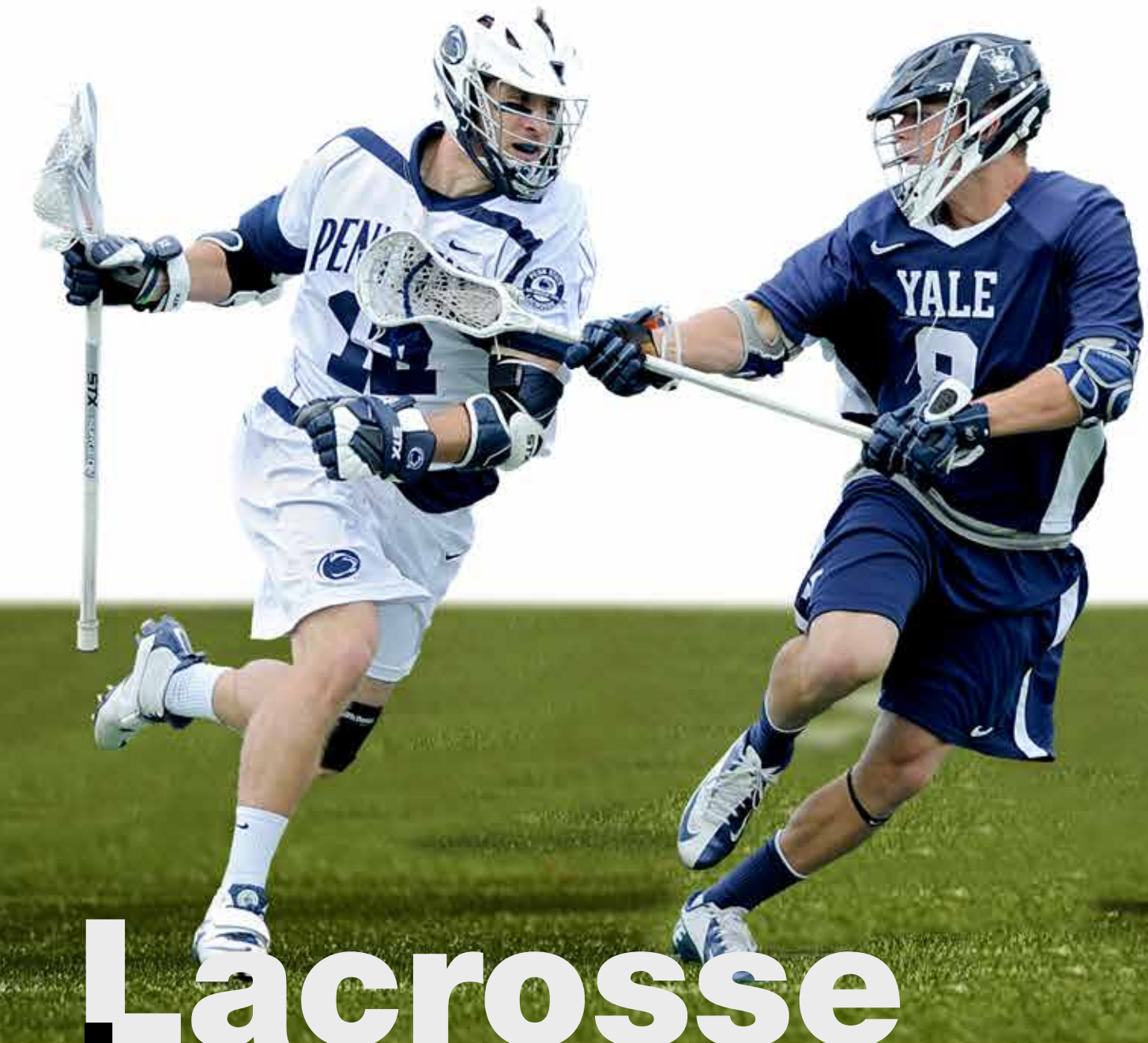

Lacrosse Lacrosse

We've been at the forefront of the impressive growth of Lacrosse. LAX players of all ages are playing on FieldTurf, from local clubs to the top college teams. Some of the best programs chose FieldTurf. It can take a beating and still provide the world-class performance you demand.



Rugby Rugby

FieldTurf's infill provides the same biomechanical properties as natural grass, giving players the best possible footing. Investing in a turf field means your surface will stand up to the constant beating your Rugby programs can put on a field.



Syracuse University



University of Louisville



Cardiff Arms Park - UK



University of Notre Dame



THINK BIG

Some of the largest sports complexes in the world look to FieldTurf to bring their vision to life.

Golden Eagle Regional Park
Sparks, NV
13 Fields - 1,400,000 sq. ft.

Medford Sports Park
Medford, OR
11 Fields - 968,000 sq. ft.

Washington State University
Pullman, WA
7 Fields - 878,322 sq. ft.

University of Notre Dame
Notre Dame, IN
6 Fields - 717,444 sq. ft.

Starfire Sports Complex
Tukwila, WA
8 Fields - 632,000 sq. ft.

Chino Hills Community Park Field
Chino Hills, CA
6 Fields - 615,000 sq. ft.

Regional Athletic Fields
Lacey, WA
6 Fields - 552,000 sq. ft.

Warhill Sports Complex
Williamsburg, VA
6 Fields - 510,000 sq. ft.

Mass Youth Soccer Association
Lancaster, MA
5 Fields - 445,000 sq. ft.

Syracuse University
Syracuse, NY
5 Fields - 432,474 sq. ft.

Rutgers University
New Brunswick, NJ
4 Fields - 424,421 sq. ft.

Ohio State University
Columbus, OH
5 Fields - 288,977 sq. ft.

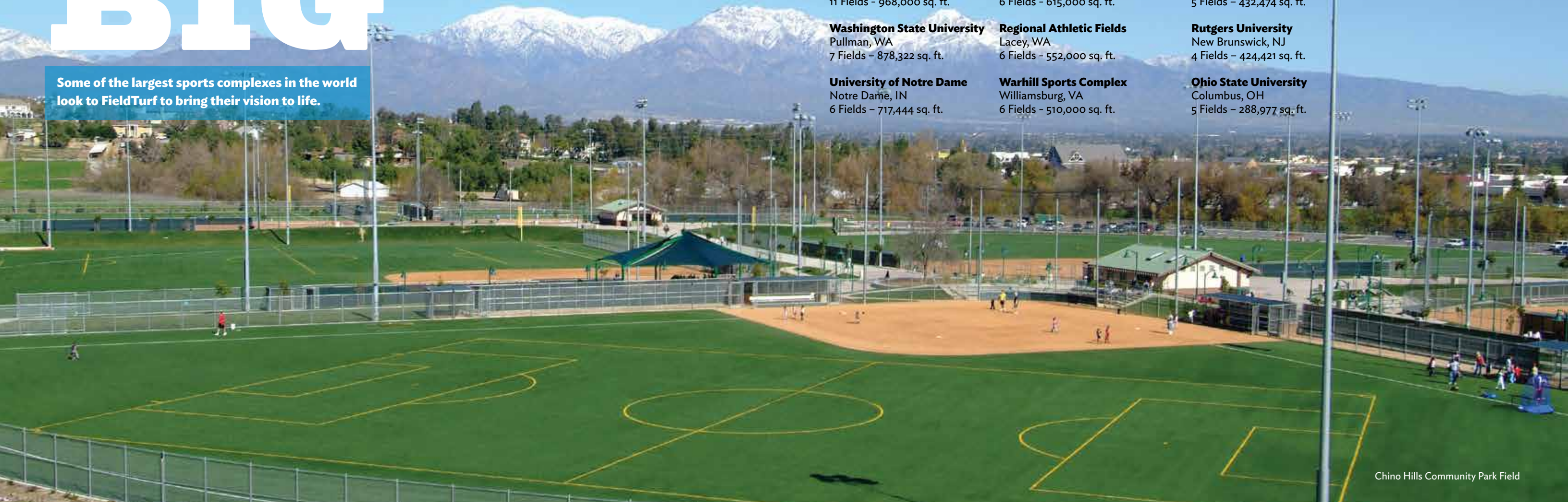

Chino Hills Community Park Field

THINK PROUD

Nothing gives us more pride than being selected to provide the right turf to our troops wherever they may be.

United States Air Force Academy

United States Military Academy

United States Coast Guard Academy

United States Naval Academy



what the experts say!

SAFE
DURABLE
PROVEN



KEVIN ANDERSON
DIRECTOR OF ATHLETICS
UNIVERSITY OF MARYLAND

"This FieldTurf project has been an overall success for the University of Maryland. Our playing surface at Capital One Field at Byrd Stadium has improved student-athlete safety through this innovative CoolPlay technology. We also now have had the ability to attract outside events to our campus, generating revenue and continuing to improve the on-campus lives of our students and our community."



TOM CALDER
DIRECTOR OF ATHLETICS AND RECREATION
JOHNS HOPKINS BLUE JAYS

"After looking at different options, FieldTurf was the best choice for us. We believe playing on FieldTurf's baseball-specific product will further develop our program and give us an excellent opportunity to continue our winning tradition."



MARK RICHT
HEAD FOOTBALL COACH
UNIVERSITY OF GEORGIA

"When we were looking to replace our synthetic field, I wanted to continue our relationship with FieldTurf. We like the quality and we are very excited about using CoolPlay. It will reduce the temperature of our turf for the safety of our players."



TERRY HOSSACK
ASSOCIATE VICE-PRESIDENT
UNIVERSITY OF TULSA

"We couldn't be happier with the new FieldTurf CoolPlay turf system. The field is noticeably cooler as promised and the players love it! The CoolPlay system is a great way to battle the Oklahoma heat and keep our players safe. It is impressive how FieldTurf created a cool high performance artificial turf system; it's just what we needed."



JOEY SAPUTO
PRESIDENT
MONTREAL IMPACT

"We are proud to offer the local community a good quality field, all the while having it available for use for all the club's teams, from the Espoirs in our sport-etudes program all the way to the pros in MLS. This new field is another step in the progression of our club and our sport."



DON PATKO
ATHLETIC DIRECTOR FACILITIES OPERATIONS
OHIO STATE UNIVERSITY

"Since we started on FieldTurf in 2007 at the stadium, our surface has consistently provided excellent footing for our players throughout the season."



DANNY MACIOCIA
HEAD FOOTBALL COACH
UNIVERSITÉ DE MONTRÉAL

"Our FieldTurf field has been a key part of our success! The ability to start using our field earlier in season has been instrumental in developing our athletes and team play. We are beyond impressed with the consistency and performance of our field."



JIM NOLAN
SENIOR VICE PRESIDENT OF FINANCE,
ADMINISTRATION & OPERATIONS
NEW ENGLAND PATRIOTS

"When we made the decision to install a new turf surface, we underwent an extensive evaluation and testing program of many other turf products in the marketplace. Selecting the FieldTurf Revolution product was a well-informed decision. What we are getting is an elite level turf system that will significantly benefit our players for years to come."



ELMAR BOLOWICH
HEAD MEN'S SOCCER COACH
CREIGHTON UNIVERSITY

"FieldTurf Revolution is an exceptional product. It has proven its worth in terms of durability, playability and visual appeal. FieldTurf has significantly contributed to the fact that Morrison Stadium is considered the #1 college soccer venue in the country."



NEEL DURBIN
DIRECTOR OF SCHOOLS
DYERSBURG CITY SCHOOLS

"FieldTurf has exceeded our expectations at every level. The sales personnel worked with us to meet our needs with the product and scheduling. The TCPN procurement process sped up the process and guaranteed a low price for our needs. The installation team was efficient, friendly and professional and every step was ahead of schedule."



TODD WHITTING
HEAD BASEBALL COACH
UNIVERSITY OF HOUSTON

"FieldTurf DoublePlay plays more like a natural ball field than anything else we have seen. From a product and company standpoint, FieldTurf is the right choice for us."



JOHN HAVERSTOCK
STADIUM MANAGER
McMAHON STADIUM

"We went and visited other facilities with the surface and we also received input from (Stamps equipment manager) George Hopkins and (assistant general manager) Mike Petrie based on the players' experience with turfs in other CFL stadiums. FieldTurf does many, many fields across North America and in fact I believe its market share is greater than all of its competitors combined."



JAIME SHERWOOD
DIRECTOR OF ATHLETICS
WAYZATA HIGH SCHOOL

"We had our initial FieldTurf field for a decade now and can confidently say that this investment has paid dividends throughout our entire organization both immediately in the short-term and each and every year thereafter."



TIMOTHY WISE
SENIOR ASSOCIATE ATHLETIC DIRECTOR
UNIVERSITY OF MIAMI

"We feel as though this upgrade to FieldTurf for our facility sends a positive message to our athletes that we want them to play on the highest performing surfaces, so they can perform at their best. We did a lot of research into what surface would be best for us and this is the one."



GLEN SHILLING
HEADMASTER
DETROIT COUNTRY DAY SCHOOL

"We looked at many different products in the industry and the same holds true today as it did more than a decade ago – nothing in the marketplace compares to what the FieldTurf product offers in terms of safety and playability. When we originally decided to install FieldTurf on our Stadium Field, we expected an excellent level of service and product and that is exactly what we experienced over the last 13 years. We are excited to continue our longstanding relationship with the world leader in artificial turf."



GREG BYRNE
DIRECTOR OF ATHLETICS
UNIVERSITY OF ARIZONA

"We've been extremely pleased with our FieldTurf CoolPlay that was installed at Arizona Stadium. The surface has provided a great enhancement to our stadium and has served as a benefit for our coaches and student-athletes because of the quality of service and its much lower temperature than normal artificial surfaces. The FieldTurf, along with our other stadium upgrades, has made a tremendous difference in our environment at Arizona Stadium."

THE STAGE OF SPORTS EVOLUTION.



THE ULTIMATE
SURFACE EXPERIENCE

TOP 10

**REASONS
WHY FIELDTURF IS
THE RIGHT CHOICE**





THE WORLD LEADER IN ARTIFICIAL TURF

TOP 10 REASONS

Since the very beginning, we have developed a reputation for setting quality and innovation standards that continue to revolutionize the artificial turf industry. Our competitors will try to convince you that their products are better with features that are not proven to yield the same long-term performance results that are associated with the FieldTurf system.

Here are the Top 10 Reasons why FieldTurf continues to be the #1 choice at all levels of sport.

1

PATENTED INFILL – for the highest performance

On natural grass, athletes cut, plant and release in the earth. Not on the blades of grass. On FieldTurf's artificial turf it's exactly the same. Our infill is the "artificial" earth, with the same bio-mechanical properties as natural grass. Just like on natural grass, athletes cut, plant and release in our infill. Not on the turf fibers. That's why FieldTurf performs like natural grass and lasts so long.

A typical 2.5" elite full-size FieldTurf field contains 736,000 lbs of infill. That is 496,000 lbs more infill mass than a typical all-rubber field. Testing proves that, unlike FieldTurf's infill system, particles in lightweight infill systems tend to easily migrate in the rain, creating divots and changes in the infill levels. This infill variation significantly impacts the safety of the turf system.

The FieldTurf Patented Infill System:

- The bottom layer is comprised of clean, washed silica sand to stabilize and support the entire system.
- Numerous passes of a mix of similarly sized rubber and silica sand are then layered into the system. The rubber and sand particles are a similar size to stay in suspension.
- Larger-sized cryogenic rubber top layer ensures that the rubber remains on top, providing a safe, forgiving surface.
- Total infill exceeds 9 pounds per square foot on a typical sports field. The FieldTurf infill mix allows for optimal safety and playability.



Silica Sand



Cryogenic Rubber

THE WORLD LEADER IN ARTIFICIAL TURF

2

PROVEN SAFETY – for the health of your athletes

Our focus on safety has led to numerous injury reducing innovations and improvements. The main reason that FieldTurf continues to outperform all other turf systems in reducing injury, is our patented sand/rubber layered infill system.

The findings of long-term testing programs show that FieldTurf is safer than any other synthetic turf system and equal to – if not better than – natural grass in most critical areas of player safety. No other company can make this claim.

A three-year study of competitive high school football found that as the artificial infill surface weight decreased, the incidence of game-related high school football trauma significantly increased across numerous playing conditions.

Some of the key differences found are as follows (p/sq.ft = pounds per square foot):

Concussion Injuries Combined

- 8.3% lower incidence of injury between FieldTurf >9 p/sq.ft and 3-5.9 p/sq.ft of infill weight

Total Injuries

- 20.5% lower incidence of injury between FieldTurf >9 p/sq.ft and 3-5.9 p/sq.ft of infill weight

Severe Injuries

- 16.8% lower incidence of injury between FieldTurf >9 p/sq.ft and 3-5.9 p/sq.ft of infill weight

College Football Safety Study Results:

Incidence, Mechanisms, and Severity of Game-Related College Football Injuries on FieldTurf Versus Natural Grass (A 3-Year Prospective Study)

Michael C. Meyers, PhD, FACSM
From the Department of Health and Human Development,
Montana State University, Bozeman, Montana.

- 12% Fewer Concussions
- 40% Fewer ACL Injuries
- 20.6% Fewer Severe Injuries
- 31.4% Fewer Ligament Tears

Source: The American Journal of Sports Medicine, Vol. 38, No. 4, 2010

High School Football Safety Study Results

Incidence, Causes, and Severity of High School Football Injuries on FieldTurf Versus Natural Grass (A 5-Year Prospective Study)

Michael C. Meyers, PhD, FACSM, and Bill S. Barnhill, MD
From the Human Performance Research Center, West Texas A&M University, Canyon, Texas, and
Panhandle Sports Medicine Associates, Amarillo, Texas.

- 44% Fewer Concussions
- 33.4% Fewer ACL Injuries
- 26.6% Fewer Severe Injuries
- 33.4 % Fewer Ligament Tears

Source: The American Journal of Sports Medicine, Vol. 32, No. 7, 2004

Women’s College Soccer Study Results:

Incidence, Mechanisms, and Severity of Match-Related Collegiate Women’s Soccer Injuries on FieldTurf and Natural Grass Surfaces (A 5-Year Prospective Study)

Michael C. Meyers, PhD, FACSM

- 22% Fewer Total Injuries
- 7% Fewer Substantial Injuries
- 2% Fewer Severe Injuries
- 12% Fewer Concussions
- 18% Lower ACL and Associated Tissue Trauma Combined

Source: The American Journal of Sports Medicine, Vol 41, No. 10, 2013



THE WORLD LEADER IN **ARTIFICIAL TURF**

3

FIBER INNOVATION
– *for optimal playability*

Our fibers are produced at our very own facility in Germany. This state-of-the-art facility was opened in 2010 and as a result, has turned FieldTurf into one of the most vertically integrated companies in the world. The quality control process at the facility includes stringent testing of the yarn properties (tensile strength, uniformity, color verification).

Our sports turf systems are constructed with meticulous fiber design, aiming to serve the needs of different customers.

No matter which fiber system you choose, FieldTurf’s products are all high quality and can serve any preference.

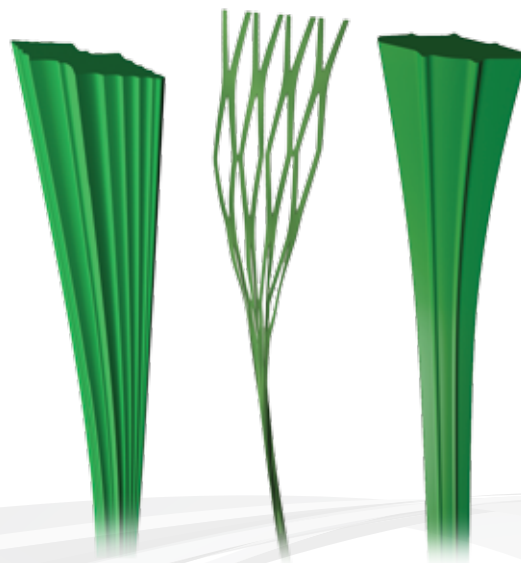

4

SURELOCK COATING
– *for maximum drainage*

FieldTurf’s patented backing offers drainage performance unequaled by any artificial turf product in the industry. A FieldTurf field is designed for all-weather playability.

Unlike the rest of the industry, the innovators at FieldTurf came up with a superior drainage solution for its Elite system. It’s called SureLock coating. This patented system coats only the rows of fiber, leaving the rest of the carpet untouched and naturally porous.

Strong Fiber + SureLock Coating = Solid Tuft Bind

Our patented SureLock coating system leaves the backing 40% porous for unmatched drainage and contributes to the highest performing tuft bind in the industry. Other products can randomly achieve good tuft bind but no one else can do it with the same level of consistency as FieldTurf.

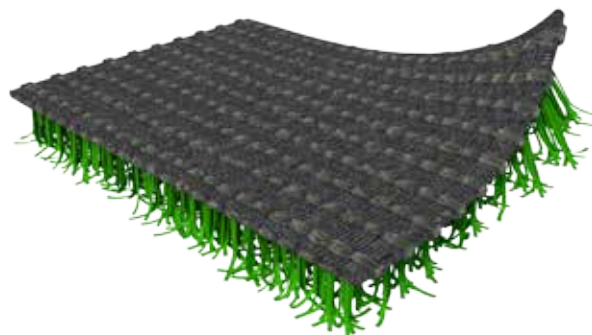

THE WORLD LEADER IN ARTIFICIAL TURF

5

MULTI-SPORT SOLUTIONS – for all sports and all levels

FieldTurf has long been the #1 choice for all sports and all levels. FieldTurf’s safety, performance and durability levels are far superior to any other system. As the world’s largest synthetic turf company, you will find FieldTurf in many major stadiums. There are no differences between a field installed at a high profile venue and one installed in a small town. For every professional or college field we build, we install the same quality field at 150 high schools and municipalities.

FieldTurf is extremely proud of the following accomplishments in the world of sports:

- 21 of 32 NFL teams have chosen to play / practice on FieldTurf
- 100+ NCAA football programs have FieldTurf
- 30+ NCAA baseball programs choose FieldTurf
- 30+ NCAA soccer programs have opted for FieldTurf
- 15 Pro soccer teams play / practice on FieldTurf
- 1000s of high school and municipal sports installations
- Over 7500 fields installed



6

SINGLE SOURCE RESPONSIBILITY – for customer security and satisfaction

FieldTurf has brought “single source responsibility” and quality to the forefront with its own manufacturing plants and quality control standards. Integrated, vertical manufacturing has paved the road toward true innovation and customer security, with fiber manufacturing, tufting, coating and testing all done in-house in FieldTurf plants. Installation is done by trained and certified FieldTurf installers.

FieldTurf is the only artificial turf company on the market to meet the most rigorous and comprehensive quality control standards:

- ISO certified manufacturing plants
- In-house fiber manufacturing
- In-house coating of all turf products
- In-house testing of each turf roll and its tuft bind
- Testing of infill and the verification of its grade
- Installation by FieldTurf certified installation crews



THE WORLD LEADER IN **ARTIFICIAL TURF**

7

INSURED WARRANTY
– *for complete peace of mind*

FieldTurf was the first company in the industry to offer a third-party insured warranty. And while you'll probably never need to use it, you can rest easy knowing that you're protected by the industry's best warranty in the unlikely event something goes wrong with your artificial turf system.

It's peace of mind that sets FieldTurf apart.

- Yearly Aggregate Claim Limit of \$32,000,000
- Per Claim Limit of \$32,000,000
- All fields are automatically covered upon issuance of the Warranty Certificate
- No deductible
- Prepaid for 8 Years

Through Tarkett, in operation since 1872, FieldTurf enjoys the strongest equity base in the entire industry. FieldTurf's Bonding Capacity of over \$75,000,000 is proof of the financial strength of a company with over 130 years of experience in the surfacing business.



8

INSTALLATION METHOD
– *for a stronger field*

FieldTurf does not cut corners when it comes to the installation of artificial turf fields.

In order to lower their prices, many competing companies will cut corners on important installation procedures. This severely compromises the durability of the entire field.

It is critical to demand proper installation standards:

- Sewn Seams = No Trip Hazards
- Meticulous Fiber Shearing = No Cuts
- Precision Infill Layering = A Safe Surface
- Experienced Installation Crews = Quality Assurance



THE WORLD LEADER IN **ARTIFICIAL TURF**

9

PROVEN DURABILITY
– for a better investment

Since its inception, FieldTurf has proven to be the most durable and longest-lasting synthetic turf system in the marketplace having installed more fields that are currently 8 years or older than all other competitor installations combined.

The FieldTurf system is not just marketing spin. It has been carefully engineered by athletes, for athletes to not only perform at the highest of levels but to do so for longer than any other turf product.

FieldTurf Fields Perform - Year After Year

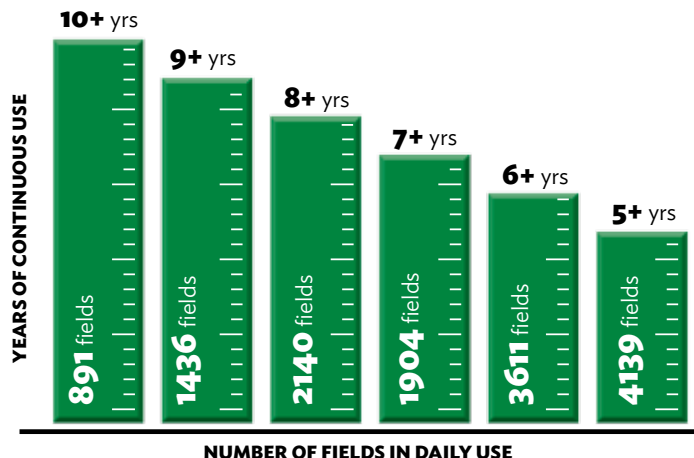

10

FIRST-CLASS SERVICE
– for your FieldTurf experience

FieldTurf does not sever its customer relations once the contract has been signed. We take the time to follow up with each and every one of our customers in order to ensure complete and consistent customer satisfaction. Our professional customer service agents are always ready to assist with any issues relating to your FieldTurf field. Whether your request is placed by phone or through email, our customer service department guarantees fast and effective solutions for all your field care needs.

Customer satisfaction remains FieldTurf's number one priority.

Every FieldTurf employee is graded on his/her performance in relation to our customers and it is a central point of focus for the development of FieldTurf as a company. We have implemented company-wide measures to guarantee complete customer satisfaction.



TOP 10 REASONS WHY FIELDTURF IS THE RIGHT CHOICE

Information

(800) 724-2969
info@fieldturf.com
www.fieldturf.com









THE ULTIMATE
SURFACE EXPERIENCE

We're even **greener** ...than we look.

This is no slogan. It's real.

We take our role as environmental stewards seriously. The whole reason behind our invention of the long pile, infilled artificial turf system was to provide safer playing fields for future generations. And that goes far beyond reducing player injuries. It means conserving natural resources, reducing consumption and recycling.

Conserving our natural resources.

 <p>Saving billions of gallons of clean water each year</p>	 <p>Eliminating the use of billions of pounds of chemicals each year</p>	 <p>Removing millions of tires from landfill sites each year</p>
 <p>Eliminating fuel-powered mowing, aerating and re-seeding</p>	 <p>Eliminating the massive CO2 emissions caused by grass clippings</p>	 <p>Providing the opportunity to obtain multiple LEED credits</p>

Converting waste into new resources.

 <p>Creating VersaTile shock and drainage tiles from old fields</p>	 <p>Turning old turf into high performance EcoMax infill</p>	 <p>Recycling old infill into new clean infill</p>
--	---	---

FieldTurf is 100% recyclable.

Our Cradle to Cradle™ certification is just part of our ongoing commitment to use recycled content in our manufacturing and then convert old turf fields into new, reusable materials. Even when a FieldTurf field finally comes to the end of its long life, it continues to help our planet.



Making a real difference.

31,066,000,000

Gallons of water saved since 1995



104,000,000

Tires diverted from landfills since 1995



329,720,000

Pounds of fertilizer eliminated since 1995





ANOTHER COOL INNOVATION FROM FIELDTURF

FieldTurf continues to sweat the details so athletes can enjoy a safe environment to challenge their limits and maximize their performance.

The experts at our Innovation and Performance Center have been hard at work finding a solution to high surface temperatures on those hot, sunny days. Years of experimenting with materials and systems have finally paid off.

CoolPlay was designed to reduce the heat without any reduction in field performance. No matter the age, sport or skill level of the athlete, CoolPlay is the cool solution.

High Performance. Low Temperature.



High Performance. Low Temperature.

High Performance. Low Temperature.

HOT FIELD? CHILL OUT.

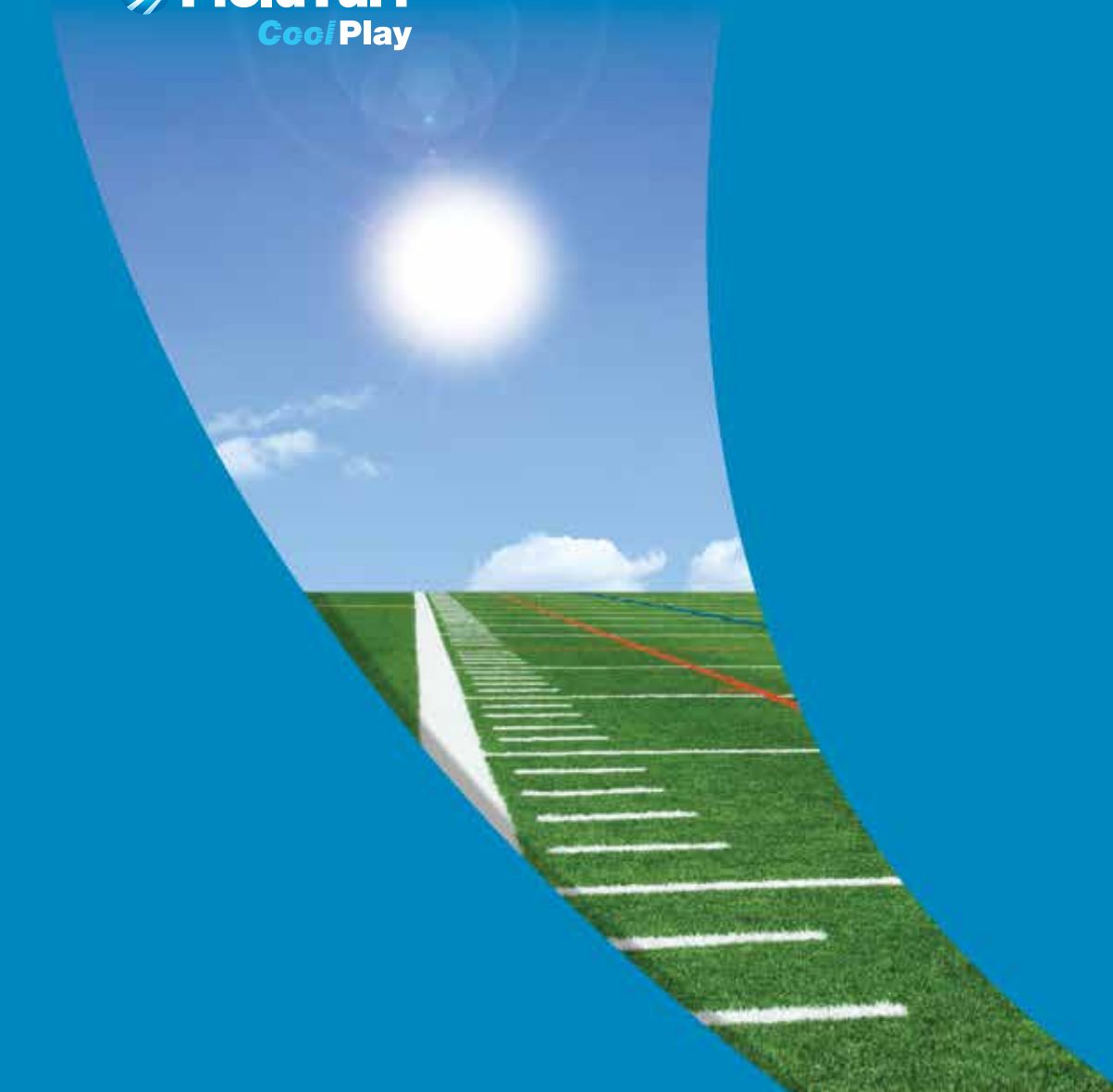

Information

(800) 724-2969
info@fieldturf.com
www.fieldturf.com



THE ULTIMATE
SURFACE EXPERIENCE



THE ULTIMATE
SURFACE EXPERIENCE



**HIGH PERFORMANCE.
LOW TEMPERATURE.**

-35°F

**LABORATORY TESTED TO BE OVER
35°F COOLER THAN TRADITIONAL
SAND/RUBBER SYSTEMS.**



CHILLING RESULTS

Hard work pays off. Our team tried everything until they found the perfect solution to the problem of hot fields. We tested it. And tested it again. Independent laboratory results concluded that CoolPlay was over 35°F cooler than traditional sand / rubber infill systems.

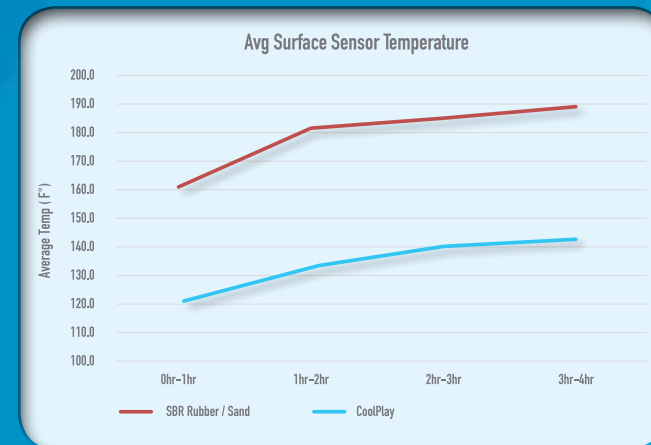

Evaluation of synthetic turf infill temperature when exposed to elevated temperature. June 2, 2016

CHILLING PERFORMANCE

CoolPlay is cool. FieldTurf's exclusive and innovative Extruded Composite top dressing allows the CoolPlay system to deliver the same behavior and overall stability as FieldTurf's Elite system fields found in the world's most famous stadiums. CoolPlay takes nothing away from performance ...except the heat!

COOL REVIEWS

"UTEP Soccer will now have one of the best artificial grass playing surfaces in the country. On top of that, the CoolPlay turf will not increase the field temperature."

Kevin Cross, Head Soccer Coach
University of Texas-El Paso

"We couldn't be happier with the new FieldTurf CoolPlay turf system. The field is noticeably cooler as promised and the players love it! The CoolPlay system is a great way to battle the Oklahoma heat and keep our players safe. It is impressive how FieldTurf created a cool high performance artificial turf system; it's just what we needed."

Terry Hossack, Associate Vice-President
University of Tulsa

CHILLING DESIGN

CoolPlay wasn't developed just to be cool. In designing the system, we ran a multitude of tests with one goal in mind: cooler surfaces with no compromise to the safety and performance of our fields.

- Crumb rubber as a top layer absorbs heat, causing the surface temperature to rise.
- An all-sand system may be cool, but the surface would be far too hard.
- Our organic and sand system is also cooler, but only CoolPlay offers a surface with ideal safety and performance.

Testing finally led us to the special CoolPlay top dressing that could replace the top layer of crumb rubber on our patented three-layer infill system – which is proven to offer better performance and safety in over 4,500 fields around the world.

The CoolPlay granule is durable, shock absorbing and absorbs far less heat than other alternatives.

SAVING MONEY IS ALSO PRETTY COOL

The existing alternative to CoolPlay is irrigation – which only provides temporary relief from high temperatures. Compared to a cost of about \$75,000 to install an irrigation system on a typical field, CoolPlay can save you a significant amount of money. Besides, irrigating an "artificial" turf field just doesn't make any sense. Any way you look at it, CoolPlay is an excellent alternative ...and saving \$40,000 is pretty cool, too!

A SAFE SOLUTION HEAVY METALS TESTING

CoolPlay has been tested to the industry standard. EN 71-3 (Par 3) toy testing - meeting all requirements.

Heavy Metal	CoolPlay	Requirements
Arsenic	<0.05	47
Lead	<0.5	60
Zinc	4	46,000



University of Nebraska



University of Arizona



University of Notre Dame



University of Tulsa



University of Georgia



University of Texas El Paso

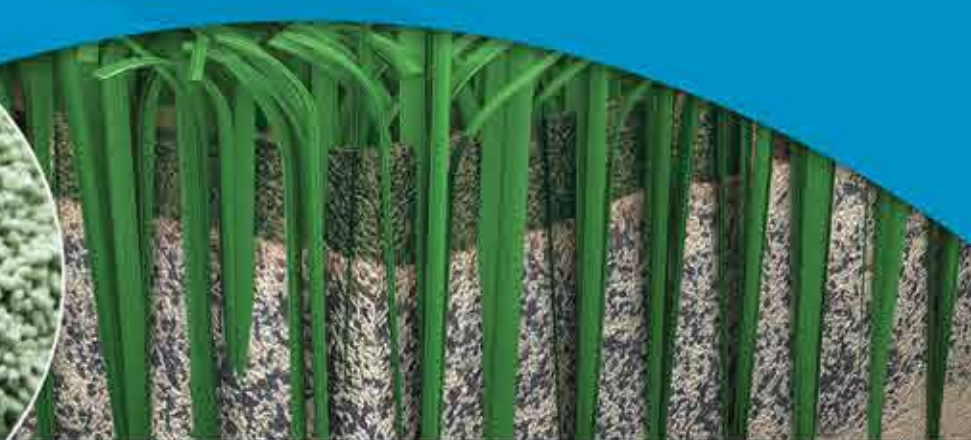

What makes FieldTurf Revolution the right system for **you?**

1. A long lasting, resilient, awesome looking fiber.

You won't believe how much science goes into these blades of grass, so let us tell you what you should look for when buying any turf fiber. It's called PPG.

POLYMER, PROCESS, AND GEOMETRY.

POLYMER FieldTurf Revolution uses a high grade polymer that was designed specifically for our turf. We gave it a great catalyst (Metallocene) and a super protective UV package (10,000 HALS of the best stuff we could find).

PROCESS Very few companies make their own turf fibers. We do. FieldTurf Revolution is made with state-of-the-art extrusion and precision manufacturing processes. Our extended, slower production line increases the "healing" time of the fiber, creating a much longer-lasting fiber.

GEOMETRY There are a bunch of geometries available. Which one works best? Focus on the results - durability and resilience - rather than the marketing stories. FieldTurf Revolution's intricate concave and ridged construction eliminates breaking points and provides a more natural looking fiber.

2. An infill system that is proven to protect your athletes.

Heavy infill provides better safety and playability. FieldTurf's heavyweight patented infill system is the real secret. While fibers provide aesthetic value, it is the infill that delivers what the athlete needs to perform. FieldTurf's Elite systems offer the heaviest infill in the industry - with up to 9.2 lbs of infill per sq. ft.

3. The best draining turf system available.

Torrential downpour? No problem. Our patented finger unit coating seals only the rows of fibers, leaving 40% of the backing completely porous, for unmatched drainage. Other systems simply coat the entire carpet backing and burn holes for water to drain through. It's a fact, nothing drains better than FieldTurf Revolution.

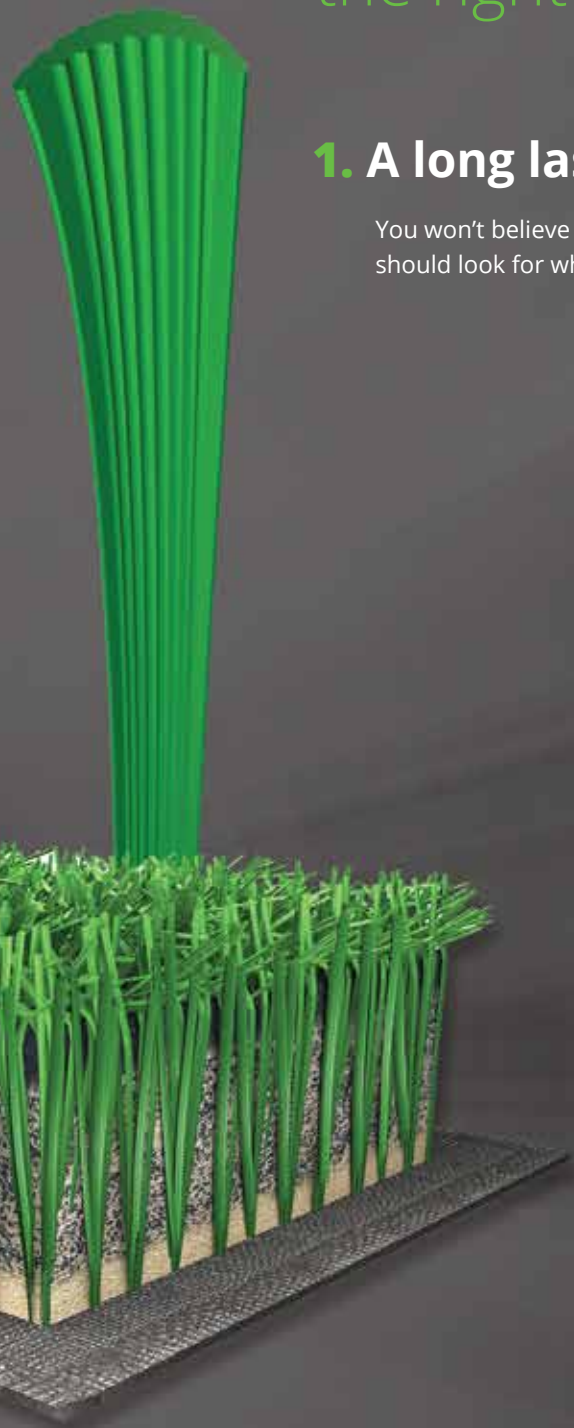

SPORT DEMANDS REVOLUTION



Information (800) 724-2969 | info@fieldturf.com | www.fieldturf.com



SPORT DEMANDS
REVOLUTION



Welcome to a
real Revolution.

This is the fiber that started a turf industry Revolution. FieldTurf Revolution now provides our customers with sports field performance that expands the limits on

DURABILITY, AESTHETICS, AND RESILIENCE.

FieldTurf Revolution is much more than just an awesome looking fiber. It's part of a unique turf system that is designed to provide your athletes with maximum

SAFETY AND PLAYABILITY.

The world's leading athletes can feel the difference. Your athletes will too. That's what makes FieldTurf Revolution such an

AMAZING TURF SYSTEM.

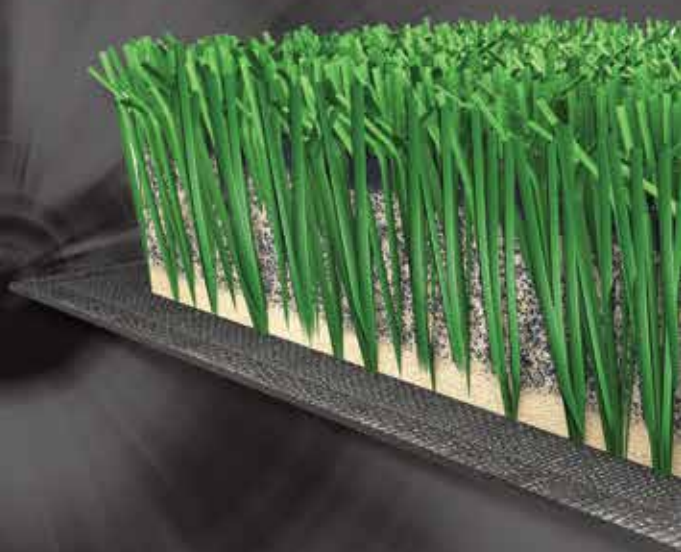

"I personally went across the country looking for the safest and most elite playing surface for the Western Michigan football program. Every time, we came back to FieldTurf. FieldTurf is the highest performing turf system on the market today - and that is why we will continue to have their product in Waldo Stadium. My priority is the safety of the young men on this team and I am confident FieldTurf is the right choice for the Broncos moving forward."

P.J. Fleck
Head Football Coach
Western Michigan University



"FieldTurf Revolution is an exceptional product. It has proven its worth in terms of durability, playability and visual appeal. FieldTurf has significantly contributed to the fact that Morrison Stadium is considered the #1 college soccer venue in the country."

Elmar Bolowich
Head Men's Soccer Coach
Creighton University



400

HIGH SCHOOLS

FieldTurf Revolution withstands the toughest use, surviving games, classes, band practice and every day punishment from America's busiest high schools.

800,000

HOURS

Many years of passion and effort went into the design, testing, development and production of this Revolutionary fiber.

7/11

RIDGED CONSTRUCTION

The engineered ridge design features 7 interior and 11 exterior ridges, reducing break points to provide Revolutionary durability.

9.2

POUNDS

That's the weight of infill per square foot in our 2.5" Elite system - keeping athletes of all ages safe.

118

INCHES

That's how much water drains through our patented finger unit backing each hour - the best draining carpet in the business. TSI Report #50278F

525

HAPPY CUSTOMERS

In less than 3 short years, FieldTurf Revolution has been selected over and over in the toughest competition.

#1

IN DURABILITY

Its durability is proven in head-to-head testing. Check out the results from the Penn State fiber wear testing.

TRUSTED BY THE BEST CUSTOMERS IN SPORT.

Look around the world and you will see the best teams and facilities - for any sport - trust the world's leading turf system, FieldTurf Revolution.



WANT TO KNOW HOW DURABLE FIELDTURF REVOLUTION IS?

Just ask the experts who put over 10 of the leading turf fibers to the test. The results validate our philosophy - proof that we put our durability claims where our science is.

Penn State's Synthetic Turf Fiber Wear Test wore various turf samples using the industry standard Lisport test. The samples were verified at 10,000, 20,000 and 30,000 cycles. After each interval, 10 fiber strands were analyzed for each sample and categorized. **Here are the results after 30,000 cycles:**

	Good	Hair Splitting	Fractured	Complete Splitting
Astroturf GameDay Grass 3D60H	0	1	7	2
Astroturf GameDay Grass 3D with Astroflect	0	0	3	7
ATG Sports RamTurf	4	6	0	0
FieldTurf Revolution	7	3	0	0
Hellas Matrix	1	7	2	0
Mondo 3NX	1	1	2	6
Shaw Sportex PowerBlade HP+	4	5	1	0
Sprinturf Ultrablade DF	0	1	6	3
UBU MNG9	4	4	1	1
UBU M4M	5	5	0	0
UBU M6M	6	4	0	0

Synthetic Turf Fiber Wear Test - Progress Report, November 2011
For more information visit: <http://plantscience.psu.edu/research/centers/ssrc/documents/lisport-report.pdf>



The winners of Super Bowl XLVIII have counted on FieldTurf since 2002. With FieldTurf in their practice facilities and in their home stadium, the Seahawks were one of the first NFL teams to recognize the benefits of FieldTurf. When you can choose any turf, it's nice to know that champions choose FieldTurf Revolution.



FIELDTURF

Classic

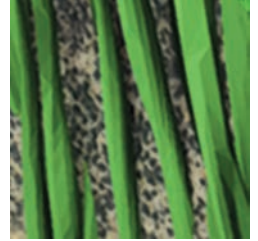

Durability
Redefined.

Classic HD



Classic HD

Durability Redefined.



Classic HD combines the proven durability of the very best in slit-film yarns with an upgraded production process to deliver the perfect combination of softness and stiffness. Its unique extrusion and inline precision cutter eliminates excess splitting, for longer-lasting performance. Complete with FieldTurf's patented infill system and known to reduce infill movement, the Classic HD System provides exceptional durability and a great investment at any level.



Durability without compromise. *It's part of FieldTurf's DNA.*

- Upgraded slit-film production process
- Ideal combination of softness and stiffness
- Excellent infill encapsulation
- 1500+ slit-film fields installed

FieldTurf Classic HD	FTHD-1	FTHD-57	FTHD-2
Pile Height:	2.5"	2.25"	2"
Pile Weight:	36 oz/yd ²	33 oz/yd ²	30 oz/yd ²
Total Infill Weight:	9 lbs+ /ft ²	8 lbs+ /ft ²	6 lbs+ /ft ²
Total Product Weight:	1381 oz/yd ²	1263 oz/yd ²	950 oz/yd ²

Warranty	■ 8 Years Insured ■ No Deductible ■ No Retention Period
-----------------	---



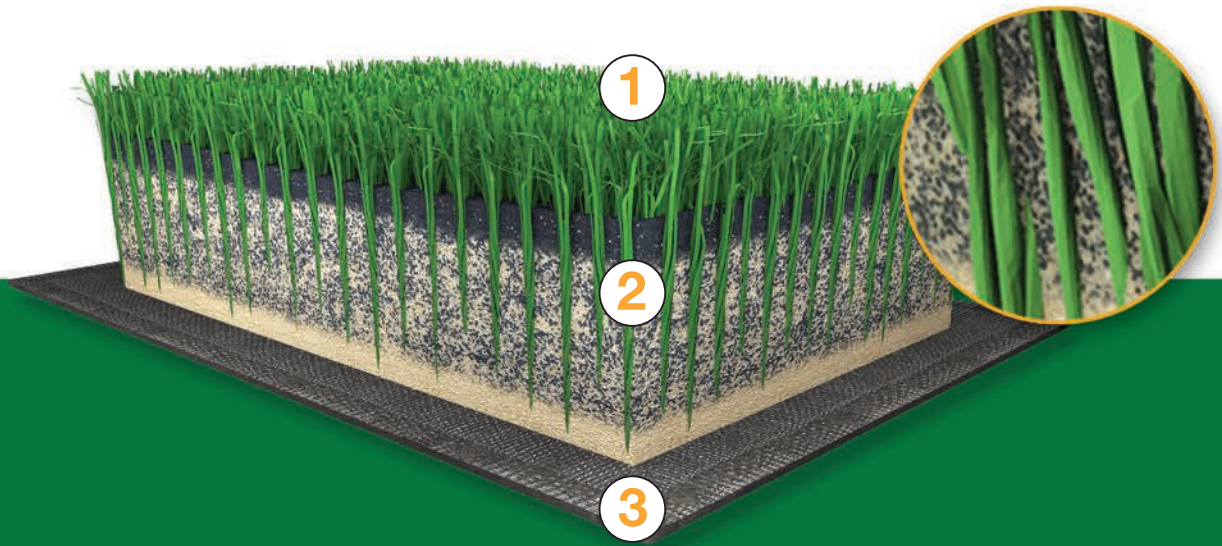

The Only Engineered System

1 Classic HD Fiber

Designed to be the very best slit-film fiber ever produced, Classic HD fibers are manufactured through an upgraded production process which reduces the amount of slits made to the fiber - allowing for much thicker fibers that are built to be much stronger. The fibrillation process of the Classic HD fibers splits the open end at the top of each fiber. The fibers then lay over on the surface and encapsulate the infill.



2 FieldTurf's Patented Infill

Specially sized cryogenic rubber particles and washed silica sand granules are layered, in a patented installation process. The grains of infill material settle inside the tiny honeycomb pockets in each fiber. This provides ideal player safety and performance that lasts longer than any other.



Silica Sand

Cryogenic Rubber

3 SureLock Coating System

Our patented SureLock coating system leaves the backing 40% porous for unmatched drainage and contributes to the highest performing tuft bind in the industry. Other products can randomly achieve good tuft bind but no one else can do it with the same level of consistency as FieldTurf.



SURELOCK



Durability Redefined.



Information

(800) 724-2969
info@fieldturf.com
www.fieldturf.com



THE ULTIMATE
SURFACE EXPERIENCE

THE ULTIMATE PORTABLE FIELD

EASYFIELD

Easy, Durable, High Performing
...and Portable!

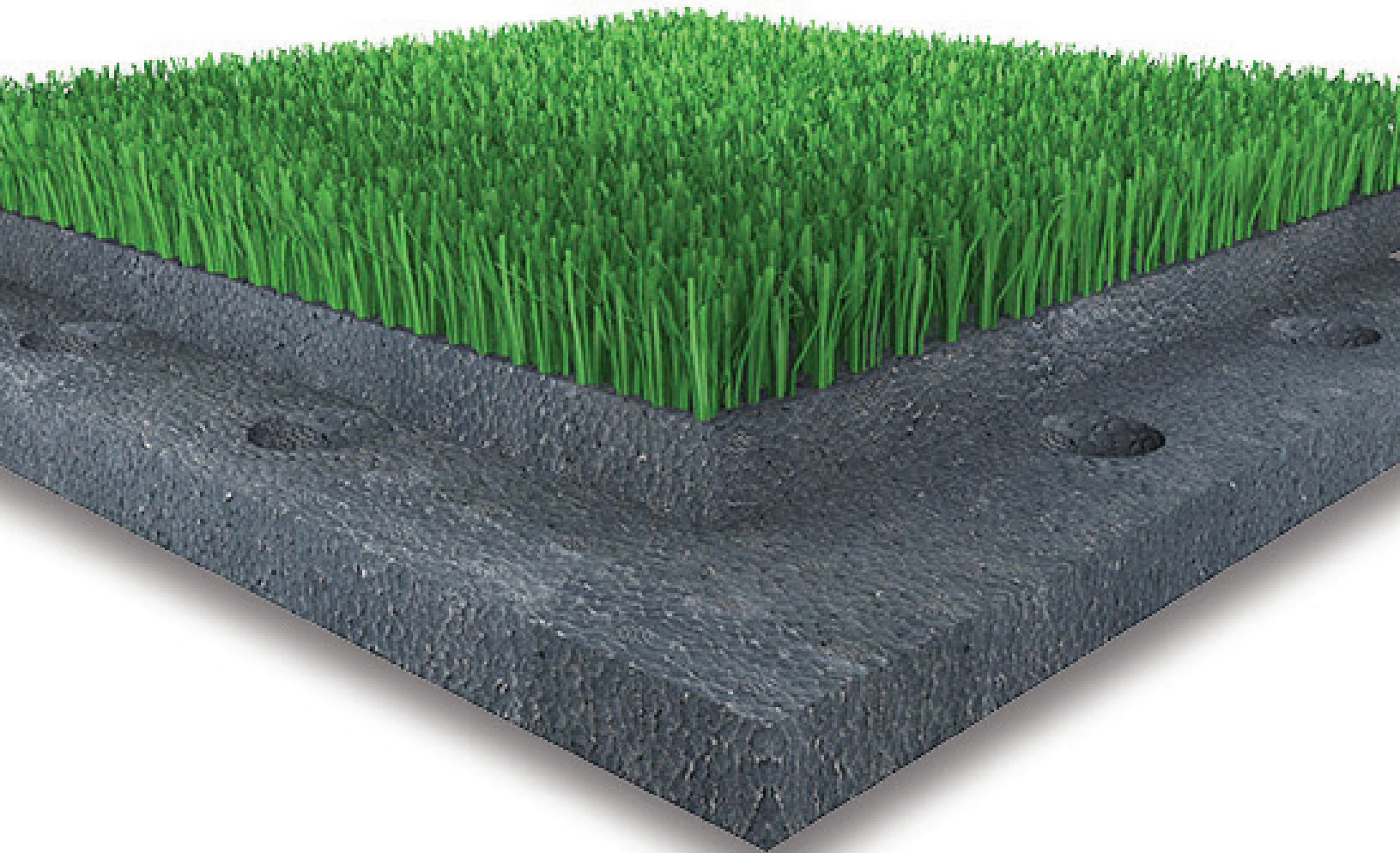



The **EASIEST** way to convert your surface **into a playing field**

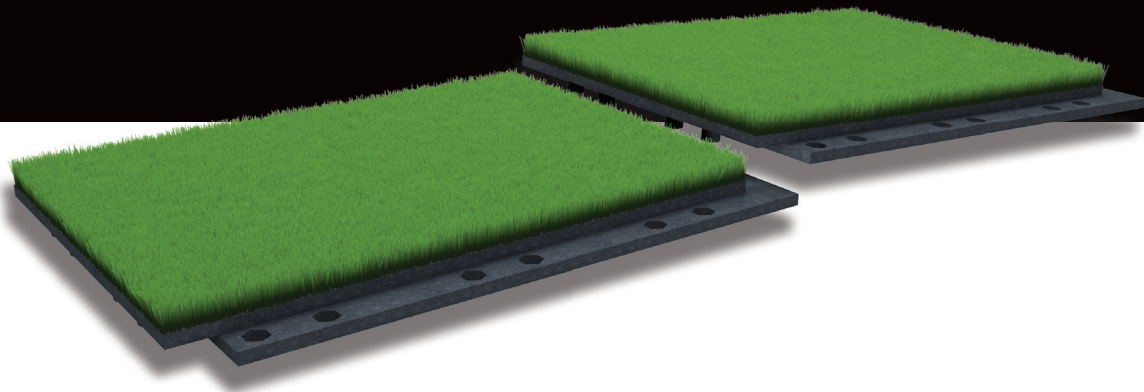

EasyLock Interlocking System

FieldTurf engineered the easiest, fastest and most secure way of locking your portable field panels together. Easylock is a simple male-female interlock system that fits your panels together perfectly for a seamless feel.

The Perfect Panel Size

The turf area of each panel has a dimension of 5.17 ft x 3.44 ft. At just 21 pounds, each panel is extremely light weight for easy carrying, maneuvering and installation.

From Floor to Field in Just Hours

Installing a good sports field has never been this easy. Our do-it-yourself system is so simple, a small crew of people can install a full size field (17,000 sq ft) in less than a day. No special equipment. No heavy lifting.

FieldTurf®
EASYLOCK

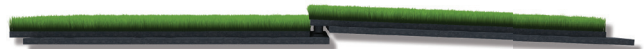
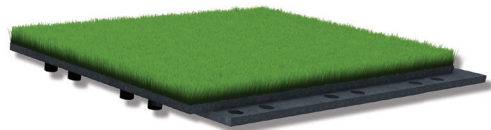

THE ULTIMATE PORTABLE FIELD



The **ULTIMATE** in **DURABILITY** for a portable field

Durable Turf

EasyField has best tested under rigorous conditions and has been designed to outlast any portable system under the harshest use. After 20,000 cycles on the Lisport Wear Machine, the turf still looks and plays great.

Durable Connectors

Dismantle and assemble your field with confidence - your field can take it! The innovative panels have been tested to keep their shape and properties through rigorous simulated durability testing

Durable Safety

EasyField's 45mm compressed foam pad provides excellent Gmax and shock absorption. Engineering has been designed to ensure little variation even after years of use.

THE HIGH PERFORMING **PORTABLE SURFACE.**

Property	Standard	Result	Ideal Range	What It Means For Your Athletes
Gmax (shock absorption)	ASTM F355	83G	< 220G	Excellent shock absorption for every athlete on your field.
Force Reduction	EN 14808	61%	60-70%	The surface absorbs the right amount of force and provides optimal spring for safety.
Deformation	EN 14809	7.5mm	4-10mm	Optimal deformation. A surface that deforms too much will result in overstretching of ligaments.
Energy Restitution	IRB	37%	30%-45%	Excellent return of energy to the athletes' legs to keep them energized and safe.
Ball Rebound	FIFA 08	0.64m	0.6m-0.85m	The ball bounce is reflective of that found on natural grass, as per FIFA's standards.
Ball Roll	EN 12234	6.5mm	4-8m	The ball roll is within the globally accepted range defined by FIFA to provide a realistic roll.

THE ULTIMATE PORTABLE FIELD





EasyField MADE FOR YOU!



Design Your Field

Curved corners? Oddly shaped areas? No problem!
We can design your custom field to fit your surface perfectly.



Be Flexible - Generate Revenue

Convert your area from floor to field and back to floor to
increase the use of your surfaces and revenue generation.



Stack 'em up

The EasyField panels can be easily stacked and stored to
provide long-lasting portable performance.



For more information visit: easy-field.com

Don't just get panels **GET A REAL FIELD!**

EasyField was designed with your facility in mind. It's a quick, convenient, portable, high performing indoor turf system.

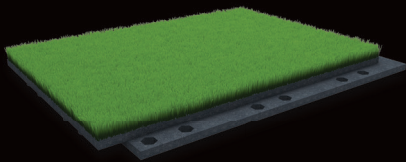

EasyField is a modular turf system that provides indoor facility owners with the ultimate in versatility – a durable, impact-absorbing turf system that can be easily removed and installed thanks to its EasyLock interlock method.



EASYFIELD

Easy, Durable, High Performing
...and Portable!

Information

(800) 724-2969
info@fieldturf.com
www.fieldturf.com



THE ULTIMATE
SURFACE EXPERIENCE

CUSTOMER CONNECT

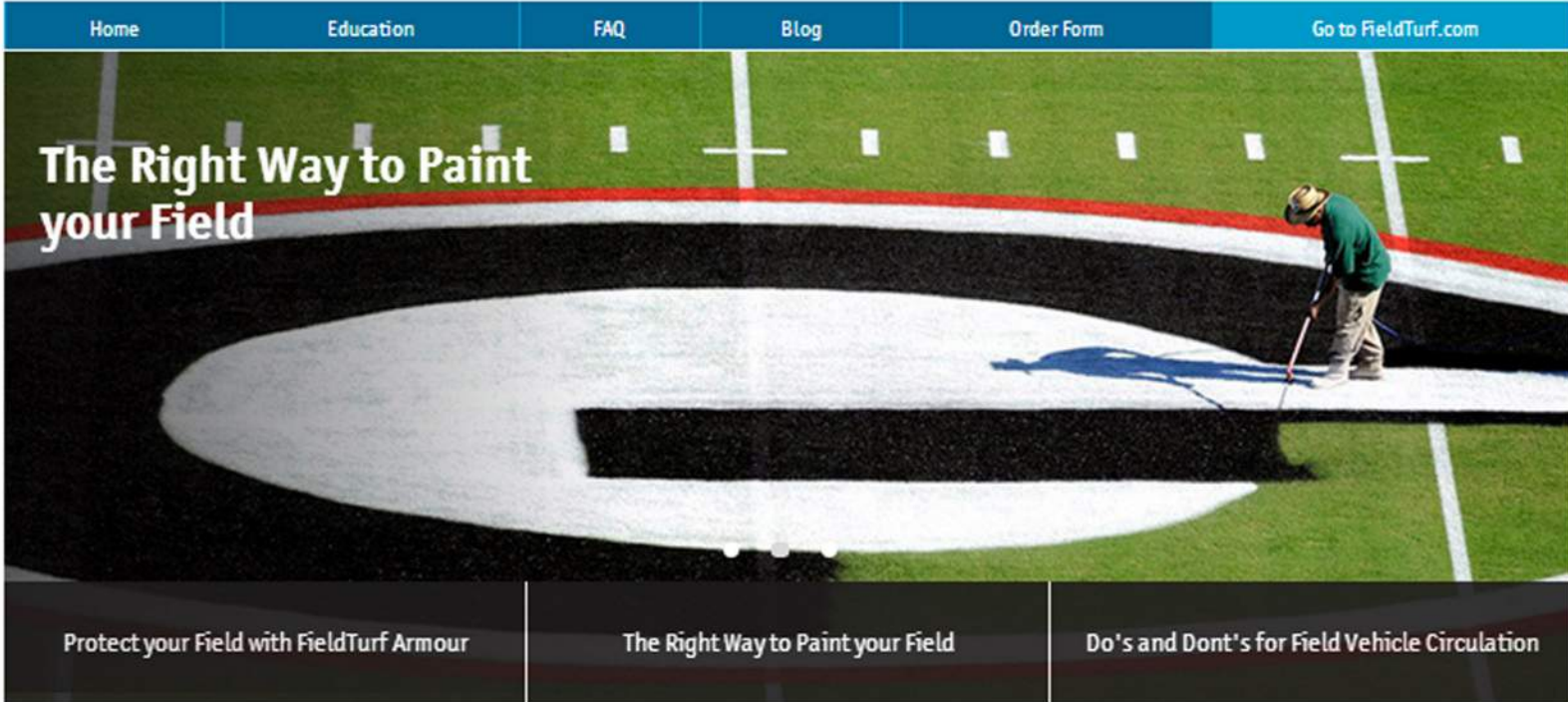

We are as **committed** to your program as you are!

And we're with you for the long term. When you buy a field from FieldTurf, you're buying from a company that knows how to take care of you. It's what we do best, and every day that your athletes play on our turf, you will understand why.

Customer Connect, FieldTurf's exclusive, customer only area helps connect you with your field! After signing up, you will gain access to a multitude of maintenance videos, brochures, articles and online store where you can now order all your maintenance supplies.

With Customer Connect you will truly feel connected with your **Field.**



Maintenance Videos



Expert Advice



Maintenance Brochures

FIELDTURF

XT

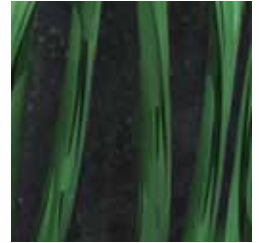

Best in
Class.

XT

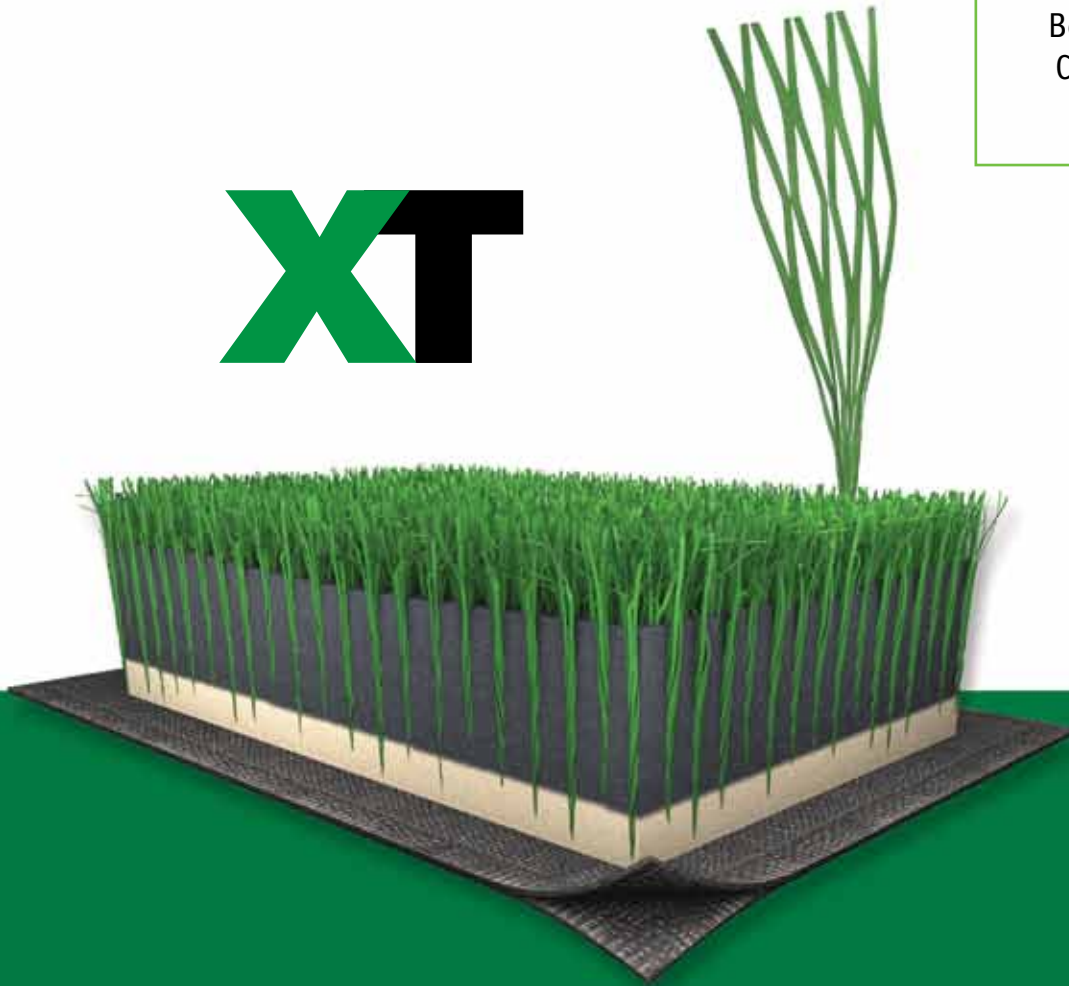



Best in Class.

The XT system is built with an innovative slit-film fiber which combines the durability of the very best slit-film yarns with an upgraded production process that delivers the perfect combination of softness and durability. The XT system is infilled with a solid 2-layer infill for proper player safety and stability. It is designed to deliver a long-lasting, high performance surface for a variety of sports.



Durability without compromise. It's part of FieldTurf's DNA.

- Upgraded slit-film production process
- An extremely durable yet soft fiber blade
- Excellent infill encapsulation
- Ballast layers of sand and top layers of rubber for world-class performance

FieldTurf XT	XT-65	XT-57	XT-50
Pile Height:	2.5"	2.25"	2"
Pile Weight:	36 oz/yd ²	33 oz/yd ²	30 oz/yd ²
Total Infill Weight:	7 lbs+ /ft ²	6 lbs+ /ft ²	5 lbs+ /ft ²
Total Product Weight:	1067 oz/yd ²	920 oz/yd ²	773 oz/yd ²



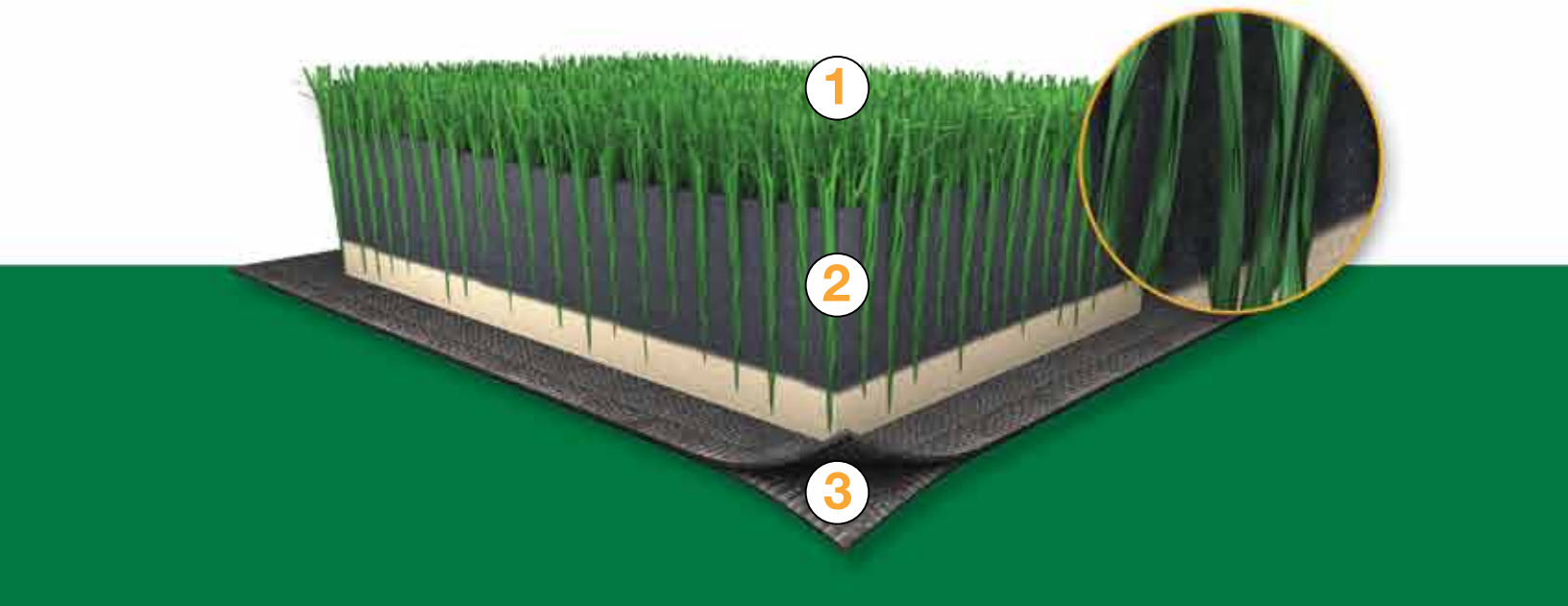

1 Slit-Film Fiber

Designed to be an extremely long-lasting slit-film fiber, the fibers used in the XT system are manufactured through an upgraded production process - allowing for more durable fibers that are built to virtually eliminate “edge decay”. The fibrillation process of the fibers splits the open end at the top of each fiber. The fibers then lay over and encapsulate the infill.



2 Two-Layered Infill

FieldTurf XT features a two-layer infill comprised of ballast layers of sand and top layers of recycled rubber granules for proper shock absorption and world-class performance.



Silica Sand

Recycled Rubber

3 Turf Backing

FieldTurf XT systems feature a dimensionally-stable backing that is coated and perforated at FieldTurf’s manufacturing facility. The result is an exceptional tuft bind strength that others cannot consistently achieve, along with excellent drainage characteristics.



Best in Class.

 **Information**

(800) 724-2969
info@fieldturf.com
www.fieldturf.com



THE ULTIMATE
SURFACE EXPERIENCE

FIELDTURF

XM6



Best in
Class.

XM6



XM6

Best in Class.



The FieldTurf XM6 system is built using a very unique triangular fiber design with 5 ridges built into the fiber for proper resilience. These best-in-class monofilament fibers are tufted into a dimensionally stable backing. The turf is then filled with two distinct layers of infill: first a stabilizing layer of silica sand is brushed into the fibers, followed by a layer of recycled rubber granules. The system is designed to deliver a long lasting, high performance surface for a variety of sports. The fibers have been built to provide excellent long-term durability.



Durability without compromise. *It's part of FieldTurf's DNA.*

- Fiber is a soft ridged monofilament
- XM6 fibers have strong wear resistance and excellent pile recovery
- The XM6 system features a dimensionally stable backing
- Ballast layers of sand and top layers of rubber infill for world-class performance

FieldTurf XM6	XM6-65	XM6-57	XM6-50
Pile Height:	2.5"	2.25"	2"
Pile Weight:	35 oz/yd ²	33 oz/yd ²	30 oz/yd ²
Total Infill Weight:	7 lbs/ft ²	6 lbs/ft ²	5 lbs/ft ²
Total Product Weight:	1066 oz/yd ²	920 oz/yd ²	773 oz/yd ²



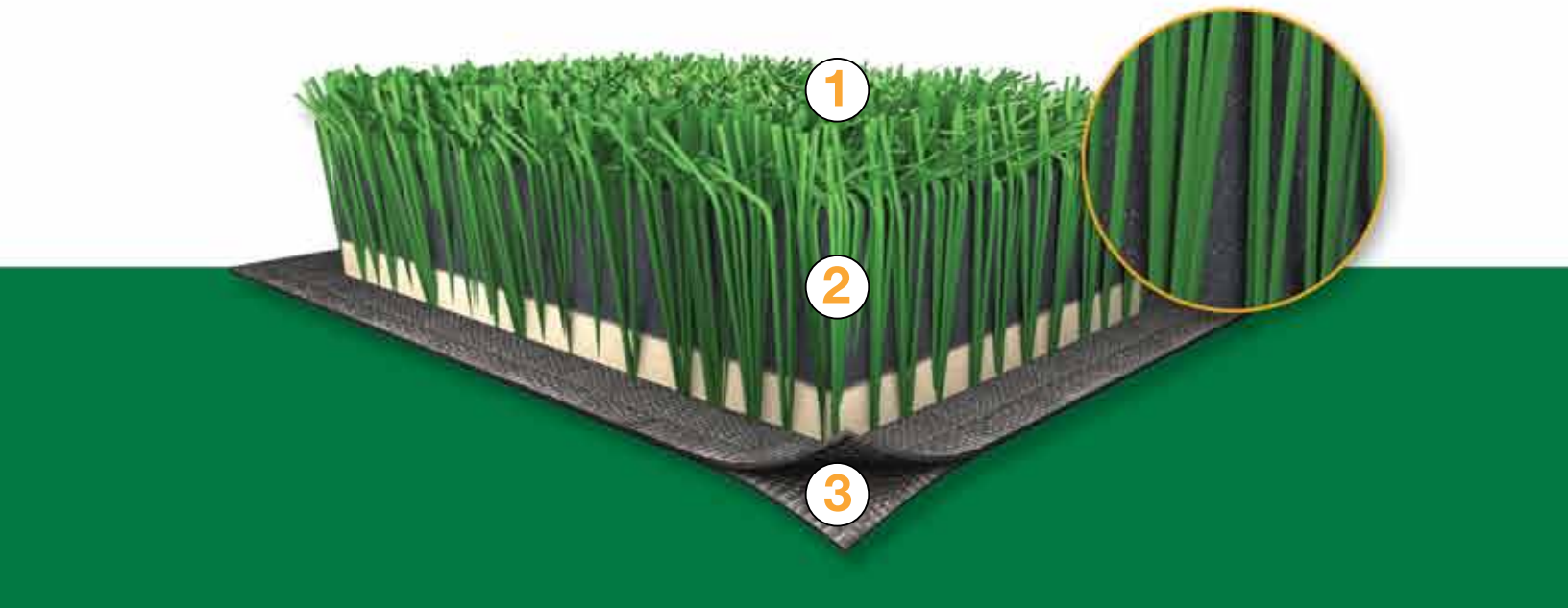

1 Monofilament Fiber

FieldTurf XM6 was developed with strict adherence to the 3 pillars of fiber development - Polymer, Process, and Geometry (PPG). The result is an exceptionally resilient and soft fiber that has been designed to provide excellent long-term durability.



2 Two-Layered Infill

FieldTurf XM6 features a two-layer infill comprised of ballast layers of sand and top layers of recycled rubber granules for proper shock absorption and world-class performance.



Silica Sand

Recycled Rubber

3 Turf Backing

FieldTurf XM6 features a dimensionally-stable backing that is coated and perforated at FieldTurf's manufacturing facility. The result is an exceptional tuft bind strength along with excellent drainage characteristics.



Best in Class.

 **Information**

(800) 724-2969
info@fieldturf.com
www.fieldturf.com



THE ULTIMATE
SURFACE EXPERIENCE



Manufacturer's Limited Warranty

FieldTurf warrants that if **FieldTurf** FTRV-1 (Product) for multi-sport use synthetic turf proves to be defective in material or installation workmanship, UV degradation, resulting in premature wear, during normal and ordinary use of the Product for the sporting activities provided herein or for any other uses for which FieldTurf provides its written authorization, within eight (8) years from the date of completion of installation (as indicated in this Warranty), FieldTurf shall either repair or replace the affected area of the Product in accordance with the terms of this Warranty. FieldTurf's sole liability under this Warranty shall be limited to either repair or replacement of the affected area of the Product, at its sole discretion, and FieldTurf shall have no other obligations or liabilities with respect to defects of the Product. FieldTurf will, at FieldTurf's option, either repair or replace the affected area to the extent required to meet the Warranty period, but no cash refunds will be made. **FieldTurf** warrants that all materials installed meet or exceed the product specifications and further warrants that replacement material will be available through the Warranty period. **FieldTurf** will verify that their representative has inspected the installation and that the work conforms to **FieldTurf's** requirements and further warrants that the installation was done in accordance with both **FieldTurf's** recommendations and any written directives of FieldTurf's representative. This Warranty shall commence upon the date of completion indicated in this Warranty. The accompanying Warranty service will not come into effect unless and until FieldTurf's Certificate of Completion is sent for validation to the corporate office of FieldTurf indicated herein within thirty (30) days of the date of completion or Purchaser's first use, whichever occurs first. In all cases, the Warranty shall be deemed to commence upon the date of completion indicated in this Warranty. The acceptance form of the terms and conditions contained in FieldTurf's Maintenance Guidelines must also be provided to FieldTurf's corporate office within thirty (30) days of completion of installation. **FieldTurf** warrants that the G-max to maintain a value of below 135 at installation and no greater than 185 for the life of the warranty, as per ASTM 1936 and F-355 standards, providing that the customer has performed the regular maintenance as outlined in the maintenance guidelines. This Warranty is limited to the remedies of repair or replacement, which shall constitute the exclusive remedies available under this Warranty; all other remedies or recourse which might otherwise be available are hereby waived by the Purchaser. FieldTurf will have no other obligations or liability for damages arising out of or in connection with the use or performance of the Product, including, without limitation, damages for personal injury and/or economic losses. This Warranty shall not come into effect, and FieldTurf shall have no obligations under this Warranty, unless and until FieldTurf is paid in full for the Product to be warranted hereunder.

Field Markings: Football, Soccer

Other Exclusions

EXCEPT AS EXPRESSLY SET FORTH IN THE MANUFACTURER'S LIMITED WARRANTY ABOVE, FIELDTURF DISCLAIMS ALL OTHER WARRANTIES OF ANY KIND, EXPRESS OR IMPLIED, IN FACT OR IN LAW, INCLUDING, BUT NOT LIMITED TO, THE IMPLIED WARRANTIES OF MERCHANTABILITY AND FITNESS FOR A PARTICULAR PURPOSE.

THIS WARRANTY SHALL BECOME NULL AND VOID IF THE PURCHASER FAILS TO MAINTAIN THE FIELD IN ACCORDANCE WITH THE FIELDTURF MAINTENANCE GUIDELINES AND SCHEDULE PROVIDED BY FIELDTURF THEREIN. ALL MAINTENANCE SHALL BE PERFORMED BY FIELDTURF-TRAINED AND/OR FIELDTURF-AUTHORIZED MAINTENANCE PERSONNEL ONLY.

Furthermore, this Manufacturer's Limited Warranty **does not cover**:

1. Damage resulting from accident, *force majeure*, misuse, intentional and unintentional abuse, infill displacement, and neglect or from other than normal play and ordinary use of the Product. For purposes of this Warranty, normal play and ordinary use shall mean usage up to 3,000 hours per year of regular play and utilization for the sporting activities provided herein; normal play and ordinary use also includes a reasonable number of users or participants, but does not include repetitive marching, repetitive training or high-intensity drills on the same part of the field, especially in the areas of, but not limited to, home plate, pitcher's mound, base areas, base paths, soccer penalty mark/spot areas, goal areas, sideline areas and lacrosse crease areas, all of which require frequent maintenance in accordance with FieldTurf Maintenance Guidelines and may require regular replacement.

This warranty is insured by a third party.

For more information please contact Customer Service at FieldTurf at the number listed below.
7445 Côte-de-Liesse Road Suite 200, Montreal, QC, Canada H4T 1G2 • Toll Free: 1-800-724-2969 •





Manufacturer's Limited Warranty

2. Damage resulting from failure to maintain the Product in accordance with FieldTurf's Maintenance Guidelines provided to the Purchaser. The Purchaser shall keep a log of all maintenance performed on the Product and supply FieldTurf with a copy upon request.
3. Damage resulting from repair, attempted repair and/or maintenance by anyone other than FieldTurf or an authorized FieldTurf distributor or authorized FieldTurf maintainer.
4. Damage due to causes which include, but are not limited to, the application of chemicals and/or cleaning agents, adhesive backing, dirt, traffic, negligence, vandalism, fire, flood, windstorm, animals, improper care and Acts of God.
5. Failure and/or improper design of the base; depression of the soil, subsurface or other matter upon which the base or Product rests; and any and all resulting damage to the Product arising therefrom.
6. FieldTurf does not warrant the percolation rate, long term planarity and/or compaction of the base which the product is installed. **FIELDTURF DISCLAIMS ALL WARRANTIES AS TO THE BASE, EXPRESS OR IMPLIED, AND ANY AND ALL RESULTING DAMAGE TO THE PRODUCT ARISING THEREFROM.**
7. Damage resulting from the use of improper footwear such as long-spiked track shoes, regular and repeated use of steel cleats, and flat-soled shoes. Standard molded soccer or football cleats are recommended.

All synthetic turf is subject to normal wear and tear, which is not a manufacturing defect and is not covered by this Warranty. In addition to the other factors listed in this Warranty, wear and tear depends on, without limitation, the construction of synthetic turf (fiber face weight, stitch rate, fiber pile height and gauge, infill components and maintenance of the field) and the intensity of use of the synthetic turf. The Product will be stable to light fading with the maximum fading of the Product during the Warranty period not to exceed fifteen percent (15%) of color loss annually based upon an acceptable grey scale. This Warranty does not cover slight variations or gradations of color within the Product and/or face distortion. Normal behavior of the fiber and infill with respect to the wear pattern of a field can be found in the "Field Settling" document, provided in the FieldTurf after-sales service package.

FieldTurf disclaims all liability for incidental and consequential damages for breach of any express or implied warranty, including any implied warranty of merchantability, with respect to the Product. In the event that the Product is used for purposes other than the sporting activities provided herein or any other uses for which FieldTurf gives its written authorization, it being understood that FieldTurf has tested the Product for use in connection with these sporting activities and may not have tested it for other uses, FieldTurf shall not be responsible for any and all damages incurred and the Manufacturer's Limited Warranty, as well as all legal warranties, shall become null and void. Any Product repairs or replacements performed under the terms of this Warranty shall not extend the term of this Warranty.

Name of Purchaser:		<input type="text"/>	
Date of completion:	<input type="text"/>	Sporting Activities:	<input type="text" value="Multi-Sport use"/>
Location:	<input type="text"/>	Installed by:	<input type="text" value="FieldTurf USA Inc."/>
Address:	<input type="text"/>	City:	<input type="text"/>
State:	<input type="text"/>	Zip:	<input type="text"/>
Tel:	<input type="text"/>	Fax:	<input type="text"/>
Signature:	<input type="text"/>	(Please Print Name)	<input type="text" value="Darren Gill"/>
Date:	<input type="text" value="November 1st, 2015"/>	Reference:	<input type="text" value="0000"/>

This warranty is insured by a third party.

For more information please contact Customer Service at FieldTurf at the number listed below.
7445 Côte-de-Liesse Road Suite 200, Montreal, QC, Canada H4T 1G2 • Toll Free: 1-800-724-2969 •





Manufacturer's Limited Warranty

FieldTurf warrants that if **FieldTurf** FTRV-1F (Product) for multi-sport use synthetic turf proves to be defective in material or installation workmanship, UV degradation, resulting in premature wear, during normal and ordinary use of the Product for the sporting activities provided herein or for any other uses for which FieldTurf provides its written authorization, within eight (8) years from the date of completion of installation (as indicated in this Warranty), FieldTurf shall either repair or replace the affected area of the Product in accordance with the terms of this Warranty. FieldTurf's sole liability under this Warranty shall be limited to either repair or replacement of the affected area of the Product, at its sole discretion, and FieldTurf shall have no other obligations or liabilities with respect to defects of the Product. FieldTurf will, at FieldTurf's option, either repair or replace the affected area to the extent required to meet the Warranty period, but no cash refunds will be made. FieldTurf warrants that all materials installed meet or exceed the product specifications and further warrants that replacement material will be available through the Warranty period. FieldTurf will verify that their representative has inspected the installation and that the work conforms to FieldTurf's requirements and further warrants that the installation was done in accordance with both FieldTurf's recommendations and any written directives of FieldTurf's representative. Warranty shall commence upon the date of completion indicated in this Warranty. The accompanying Warranty service will not come into effect unless and until FieldTurf's Certificate of Completion is sent for validation to the corporate office of FieldTurf indicated herein within thirty (30) days of the date of completion or Purchaser's first use, whichever occurs first. In all cases, the Warranty shall be deemed to commence upon the date of completion indicated in this Warranty. The acceptance form of the terms and conditions contained in FieldTurf's Maintenance Guidelines must also be provided to FieldTurf's corporate office within thirty (30) days of completion of installation. **FieldTurf** warrants that the G-max to maintain a value of below 135 at installation and no greater than 185 for the life of the warranty, as per ASTM 1936 and F-355 standards, providing that the customer has performed the regular maintenance as outlined in the maintenance guidelines. This Warranty is limited to the remedies of repair or replacement, which shall constitute the exclusive remedies available under this Warranty; all other remedies or recourse which might otherwise be available are hereby waived by the Purchaser. FieldTurf will have no other obligations or liability for damages arising out of or in connection with the use or performance of the Product, including, without limitation, damages for personal injury and/or economic losses. This Warranty shall not come into effect, and FieldTurf shall have no obligations under this Warranty, unless and until FieldTurf is paid in full for the Product to be warranted hereunder.

For the designated high-traffic areas (Home Plate, Pitcher's Mound, Base areas, Base Paths) and all synthetic turf installed anywhere on the infield, the above-noted warranty applies except that the applicable warranty period shall be limited to a two (2) year manufacturer's warranty.

Field Markings: Baseball, Softball

Other Exclusions

EXCEPT AS EXPRESSLY SET FORTH IN THE MANUFACTURER'S LIMITED WARRANTY ABOVE, FIELDTURF DISCLAIMS ALL OTHER WARRANTIES OF ANY KIND, EXPRESS OR IMPLIED, IN FACT OR IN LAW, INCLUDING, BUT NOT LIMITED TO, THE IMPLIED WARRANTIES OF MERCHANTABILITY AND FITNESS FOR A PARTICULAR PURPOSE.

THIS WARRANTY SHALL BECOME NULL AND VOID IF PURCHASER FAILS TO MAINTAIN THE FIELD IN ACCORDANCE WITH THE FIELDTURF MAINTENANCE GUIDELINES AND SCHEDULE PROVIDED BY FIELDTURF THEREIN. ALL MAINTENANCE SHALL BE PERFORMED BY FIELDTURF-TRAINED AND/OR FIELDTURF-AUTHORIZED MAINTENANCE PERSONNEL ONLY.

Furthermore, this Manufacturer's Limited Warranty **does not cover**:

1. Damage resulting from accident, *force majeure*, misuse, intentional and unintentional abuse, infill displacement, and neglect or from other than normal play and ordinary use of the Product. For purposes of this Warranty, normal play and ordinary use shall mean usage up to 3,000 hours per year of regular play and utilization for the sporting activities provided herein; normal play and ordinary use also includes a reasonable number of users or participants, but does not include repetitive marching, repetitive training or high-intensity drills on the same part of the field, especially in the areas of, but not limited to, home plate, pitcher's mound, base areas, base paths all of which require frequent maintenance in accordance with FieldTurf Maintenance Guidelines and may require regular replacement.
2. Damage resulting from failure to maintain the Product in accordance with the baseball specific maintenance and use instructions provided to the buyer. Given the nature of baseball, this warranty shall be conditional upon the owner carrying out regular baseball specific field maintenance as specified in FieldTurf's applicable maintenance manuals/guidelines and maintaining written logs showing same. The owner understands the particular baseball requirement for frequent in-fill replenishment and maintenance on bases, base paths and anywhere else in-fill is naturally displaced.

This warranty is insured by a third party.

For more information please contact Customer Service at FieldTurf at the number listed below.
7445 Côte-de-Liesse Road Suite 200, Montreal, QC, Canada H4T 1G2 • Toll Free: 1-800-724-2969 •





Manufacturer's Limited Warranty

3. Damage resulting from repair, attempted repair and/or maintenance by anyone other than FieldTurf or an authorized FieldTurf distributor or authorized FieldTurf maintainer.
4. Damage due to causes which include, but are not limited to, the application of chemicals and/or cleaning agents, adhesive backing, dirt, traffic, negligence, vandalism, fire, flood, windstorm, animals, improper care and Acts of God.
5. Failure and/or improper design of the base; depression of the soil, subsurface or other matter upon which the base or Product rests; and any and all resulting damage to the Product arising therefrom.
6. FieldTurf does not warrant the percolation rate, long term planarity and/or compaction of the base which the product is installed. **FIELDTURF DISCLAIMS ALL WARRANTIES AS TO THE BASE, EXPRESS OR IMPLIED, AND ANY AND ALL RESULTING DAMAGE TO THE PRODUCT ARISING THEREFROM.**
7. Damage resulting from the use of improper footwear such as long-spiked track shoes, regular and repeated use of steel cleats, and flat-soled shoes. Standard molded soccer or football cleats are recommended.

All synthetic turf is subject to normal wear and tear, which is not a manufacturing defect and is not covered by this Warranty. In addition to the other factors listed in this Warranty, wear and tear depends on, without limitation, the construction of synthetic turf (fiber face weight, stitch rate, fiber pile height and gauge, infill components and maintenance of the field) and the intensity of use of the synthetic turf. The Product will be stable to light fading with the maximum fading of the Product during the Warranty period not to exceed fifteen percent (15%) of color loss annually based upon an acceptable grey scale. This Warranty does not cover slight variations or gradations of color within the Product and/or face distortion. Normal behavior of the fiber and infill with respect to the wear pattern of a field can be found in the "Field Settling" document, provided in the FieldTurf after-sales service package.

FieldTurf disclaims all liability for incidental and consequential damages for breach of any express or implied warranty, including any implied warranty of merchantability, with respect to the Product. In the event that the Product is used for purposes other than the sporting activities provided herein or any other uses for which FieldTurf gives its written authorization, it being understood that FieldTurf has tested the Product for use in connection with these sporting activities and may not have tested it for other uses, FieldTurf shall not be responsible for any and all damages incurred and the Manufacturer's Limited Warranty, as well as all legal warranties, shall become null and void. Any Product repairs or replacements performed under the terms of this Warranty shall not extend the term of this Warranty.

Name of Purchaser:			
Date of completion:		Sporting Activities:	Multi-Sport Use
Location:		Installed by:	FieldTurf USA
Address:		City:	
State:		Zip:	
Tel:		Fax:	
Signature:		(Please Print Name)	Darren Gill
Date:	December 15 th , 2015	Reference:	0000

This warranty is insured by a third party.

For more information please contact Customer Service at FieldTurf at the number listed below.
7445 Côte-de-Liesse Road Suite 200, Montreal, QC, Canada H4T 1G2 • Toll Free: 1-800-724-2969 •



TRACK WARRANTY (FULL DEPTH)

Beynon Sports Surfaces guarantees the installation of the rubber athletic surface to be free from defects in materials and workmanship for a period of (5) years from completion of installation. Should any defect occur, repairs will be made free of charge. This guarantee covers only the work performed by Beynon Sports Surfaces.

The guarantee covers track and field use only, and shall not be interpreted as holding Beynon Sports Surfaces responsible for any deterioration of the work due to normal use or the abuses of the installation. Abuse of the installation specifically includes, but is not limited to:

- 1) Use of the track by motor vehicles or equipment.
- 2) Use of the track for other than track and field activity (i.e. parades, assembly, and bleachers).
- 3) Damage to the surface caused by football, soccer, or baseball.
- 4) Vandalism.

The owner acknowledges that the sub-base and the base are a completely separate installation and are not covered by this guarantee. This guarantee does not cover the base asphalt or problems in the Beynon rubber track surface which are a result of defect, cracking, shifting or deterioration of the base asphalt or vegetation growth through the base asphalt.

The track striping, when provided by Beynon Sports Surfaces is guaranteed as above to be free from defects in materials and workmanship. Fading due to normal use is excluded.

This warranty is the exclusive and sole remedy of the owner. Prior to warranty being effective, all bills associated with the installation of the track system must be paid in full.

Beynon Sports Surfaces

Project

Date

MAINTENANCE TRACK SURFACE WARRANTY

Beynon Sports Surfaces. guarantees the installation of the rubber athletic surface to be free from defects in materials and workmanship for a period of (1) one year from completion of installation. Should any defect occur, repairs will be made free of charge. This guarantee covers only the work performed by Beynon Sports Surfaces.

The guarantee covers track and field use only, and shall not be interpreted as holding Beynon Sports Surfaces responsible for any deterioration of the work due to normal use or the abuses of the installation. Abuse of the installation specifically includes, but is not limited to:

- 1) Use of the track by motor vehicles or equipment.
- 2) Use of the track for other than track and field activity (i.e. parades, assembly, and bleachers).
- 3) Damage to the surface caused by football, soccer, or baseball.
- 4) Vandalism.

The owner acknowledges that the sub-base and the base are a completely separate installation and are not covered by this guarantee. This guarantee does not cover the base asphalt or problems in the Beynon rubber track surface which are a result of defect, cracking, shifting or deterioration of the base asphalt or vegetation growth through the base asphalt.

The track striping, when provided by Beynon Sports Surfaces is guaranteed as above to be free from defects in materials and workmanship. Fading due to normal use is excluded.

This warranty is the exclusive and sole remedy of the owner. Prior to warranty being effective, all bills associated with the installation of the track system must be paid in full.

Beynon Sports Surfacing

Project

Date

COURT WARRANTY

Beynon Sports Surfaces and California Products Corp. guarantees the installation of the tennis court surface to be free from defects in materials and workmanship for a period of (1) one year from completion of installation. Should any defect occur, repairs will be made free of charge. This guarantee covers only the materials and work performed by Beynon Sports Surfaces and their sub-contractors.

The guarantee covers tennis court use only, and shall not be interpreted as holding Beynon Sports Surfaces or California Products Corp. responsible for any deterioration of the work due to normal use or the abuses of the installation. Abuse of the installation specifically includes, but is not limited to:

- 1) Use of the tennis/basketball court by motor vehicles or equipment.
- 2) Use of the tennis court for other than tennis activity.
- 3) Damage to the surface caused by vandalism.

The owner acknowledges that the sub-base and the base are a completely separate installation and are not covered by this guarantee. This guarantee does not cover the base asphalt/concrete or problems in the court surfacing system which are a result of defect, cracking, shifting or deterioration of the base asphalt/concrete or vegetation growth through the base asphalt/concrete.

The court striping, when provided by Beynon Sports surfaces is guaranteed as above to be free from defects in materials and workmanship. Fading due to normal use is excluded.

This warranty is the exclusive and sole remedy of the owner. Prior to warranty being effective, all bills associated with the installation of the court system must be paid in full.

Beynon Sports Surfaces California Products Corp.

Project

Date

**IT ALL
STARTS
AT THE
SURFACE**

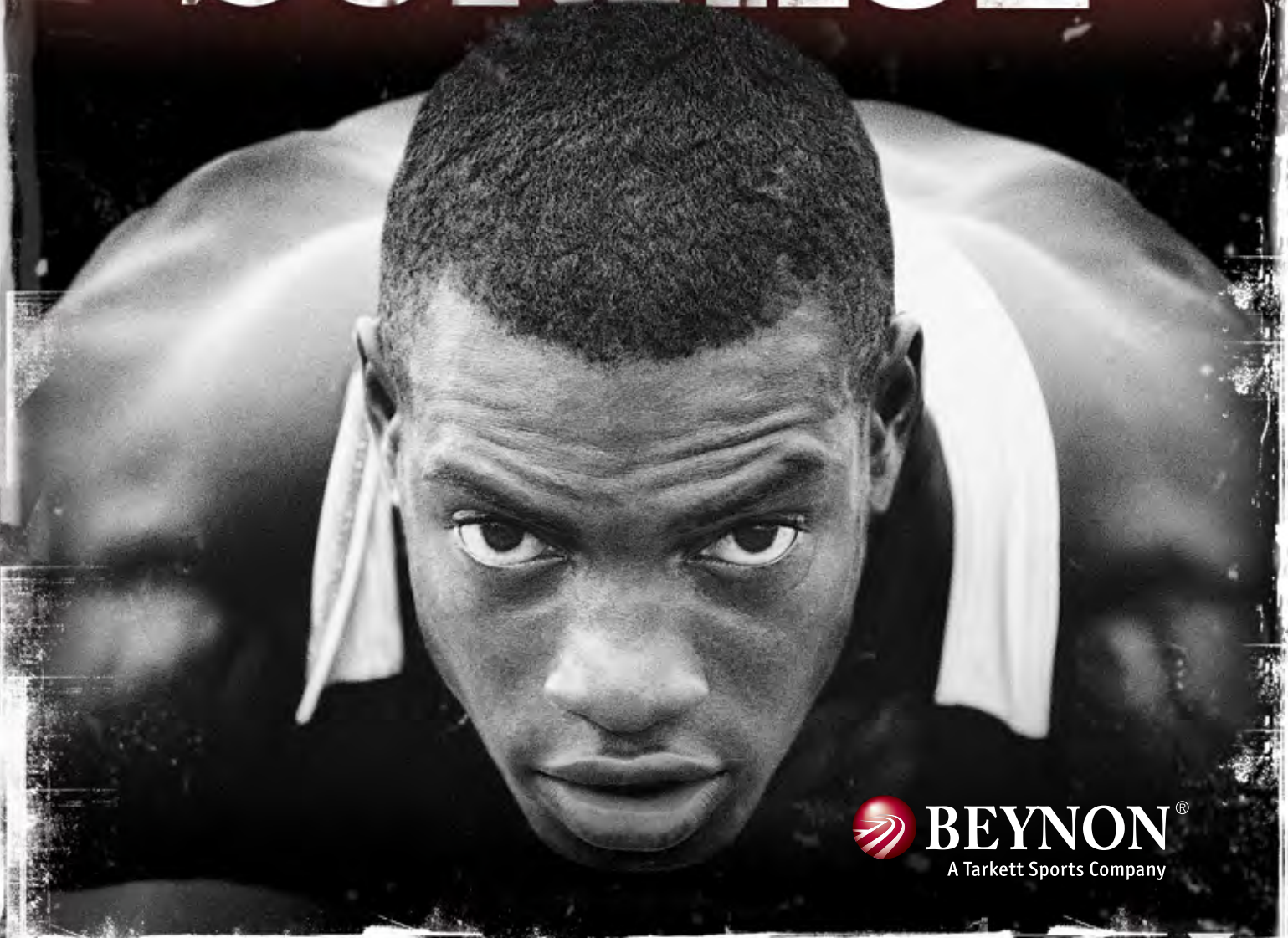

 **BEYNON**[®]
A Tarkett Sports Company

PERFECTION TO ONE-HUNDREDTH OF A SECOND



Welcome to the finish line for your training, competition, and high-performance needs for track and field.

Just as no two athletes are alike, the same holds true for our tracks—designed and built specifically to fit your program and budget while safely propelling your athletes to record-breaking times.

Beynon Sports' passion is to position you to win.

How do we do it? Read on. If you want to set yourself apart from competition, then Beynon Sports is the right choice.

**THE WORLD
IS AT YOUR
FEET.**

WE'VE BEEN THE **LEADER** IN ATHLETIC SURFACING SINCE 1971

John T. Beynon founded Beynon Sports with the vision of creating high-performance athletic surfaces designed for speed and competition, as well as daily training. Our premier track and field surfaces are found in the world's most renowned athletic facilities, carrying some of the world's greatest champions to record-breaking times. At Beynon Sports Surfaces, we take pride in our history and our accomplishments, but we're even prouder of the performance, longevity, and resiliency of our track surfaces.

In the spring of 2008, Beynon Sports joined FieldTurf and the Tarkett Sports

family, combining the most recognized and prestigious name in the artificial turf market with the celebrated Beynon Sports track and field, fieldhouse, and gymnasium sports surfacing systems.

The result is a global firm with unmatched financial strength and a dedication to innovation, customer service, and excellence.

Through this partnership, your track and field program will receive unprecedented service, quality, and support as well as the financial backing to stand behind our products as you move forward with your track and field project.

“I opted to go with a Beynon track over Mondo because I believe it to be a superior product. Our Beynon track has been in place since the fall of 2005, though if you came out to our track today, you would think it had just been poured yesterday. The Beynon track is easier on the athletes and since our track has been in place, stress fractures have become almost nonexistent.”

— Ralph Spry
HEAD TRACK AND FIELD COACH,
AUBURN UNIVERSITY

CONTACT US TO GET YOUR PROJECT STARTED

Headquarters and Manufacturing Center

Beynon Sports Surfaces, Inc.
16 Alt Road
Hunt Valley, MD 21030

PH 888.240.3670
410.771.9473
FX 410.771.9479

Regional Operations Centers



350 CR 255
Georgetown, TX 78633

PH 866.330.8150
512.778.6170
FX 512.778.6180

4263 N. Selland Avenue
Fresno, CA 93722

PH 559.840.1585
FX 559.478.4815

19495 SW Teton Avenue
Tualatin, OR 97062

PH 800.423.5875
FX 503.692.0491

Beynon Sports has regional sales offices across North America to meet the local needs of every customer.

SPEED

IS IMPORTANT.

LONGEVITY

IS VITAL

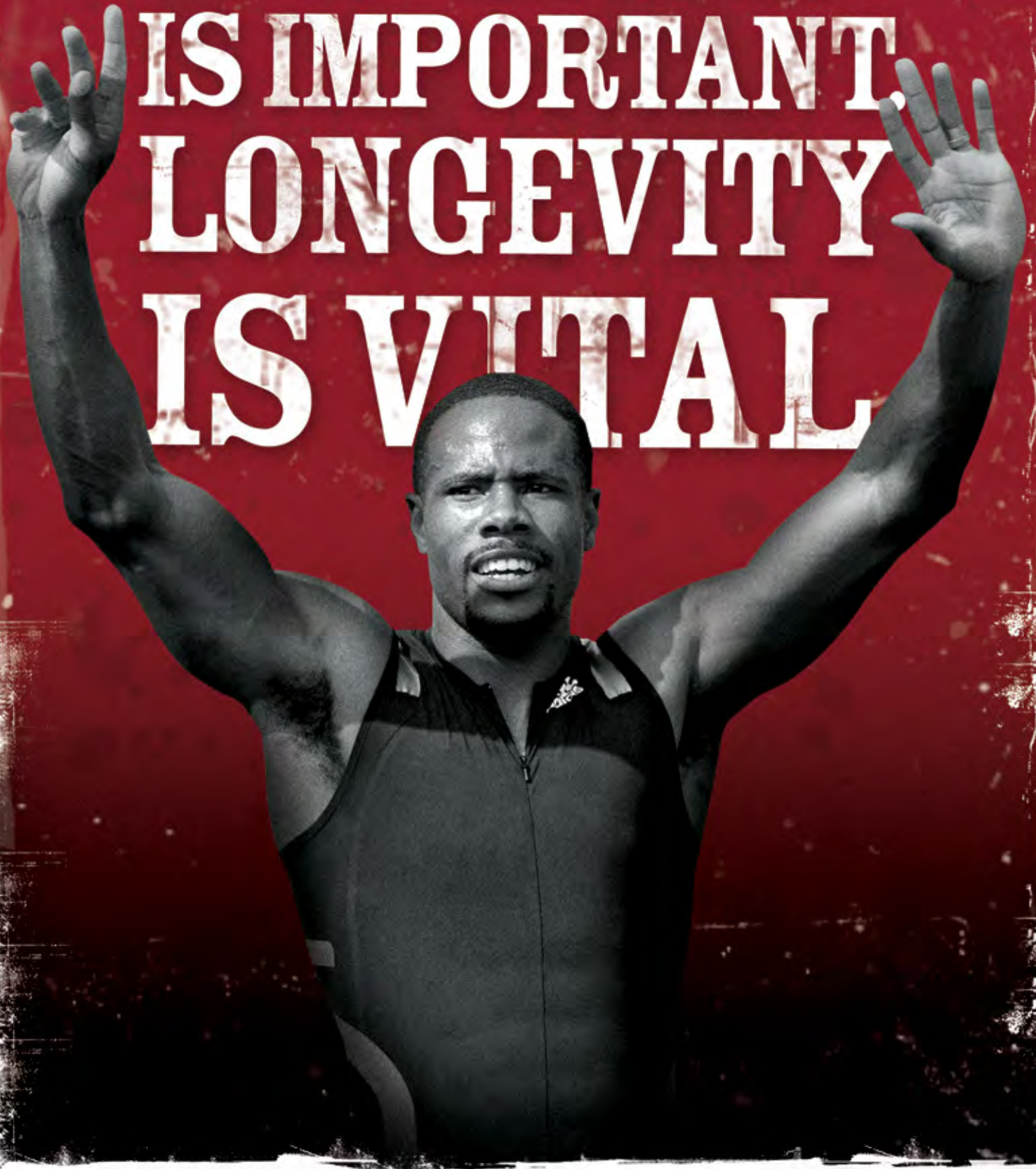

THE SCIENCE BEHIND TRACK AND FIELD



OUR CHEMISTS **CREATE** THE WORLD'S MOST REFINED SURFACES

What you see is an incredible track and field facility. What you feel is the premier surface for training and competition. Quality and attention to detail are of the utmost importance. To Beynon Sports, that means overseeing every surface from raw material selection, to manufacturing the system for the specific needs of the coaches and student-athletes, all the way through installation. It also means having our track and field systems tested and certified according to IAAF and DIN standards to ensure that your athletes receive a superior product.

We guarantee only the finest raw materials, tireless research and development, and outstanding workmanship go into each system. Our team is made up of the finest and most experienced in the industry, from world-famous track coaches to the leading polyurethane research chemists and the most experienced installation personnel. With them, and through vigorously researching and developing new environmentally sustainable technologies, we are able to bring your athletes the latest track and field surfacing innovations.

We adhere to the top standards for renewable polyols, and we are the leader in research and development of environmentally conscious products in the polyurethane sports surfacing industry.

From your initial inquiry, our dedicated team gives you undivided attention. We listen to your desires and work with you to get the precise track and field or fieldhouse system that fits your needs. Only Beynon Sports can manufacture your track to your specification, which makes it easier to give you the track surface you want, whether it is ideal for competition or perfect for extended risk-free training. Our 50,000 square foot state-of-the-art manufacturing facility is dedicated solely to the research and development, production, and quality assurance of our outdoor and indoor athletic surfacing systems.

Once the subbase of your track and field system is cured and tested for planarity, only our experienced, trained technicians or accredited applicators install your surface to ensure superior precision, performance, and workmanship.



“Last weekend on this track, Tyson Gay ran two memorable 100-meter times in two days: an American record of 9.77 seconds and then 9.68.”

— Frank Litsky
THE NEW YORK TIMES



TUNED SYSTEMS

SURFACES MADE TO FIT

Beynon Sports understands that one track does not fit all—that's why Beynon Sports is the only sports surfacing company that offers customized track and field surfaces with our TUNED Systems. Your track can be TUNED to match the desired feel under foot and force reduction range within IAAF parameters.

Customizing your track is the key to your athletes' top performance. Beynon Sports can adjust the durometer of the track and field surface to make it more forgiving for training or more ideal for competition. We can even modify the force reduction in various areas of the track to accommodate the needs of specific events.

“There was some concern that the new polyurethane track at the University of Oregon’s Hayward Field would be too slow for the sprinters at the U.S. Olympic Trials, that it would favor the distance events—so much for that theory.”

— Mark Zeigler
THE SAN DIEGO UNION-TRIBUNE

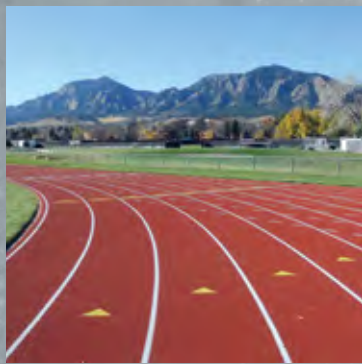

UNIVERSITY OF COLORADO

After daily use of its rubber sheet good track, the University of Colorado started seeing a trend of foot and tibia-fibula joint disorders, as well as stress fractures in its athletes. The university required a track and field surface suitable for daily training and capable of providing fast times during competitive meets. The University of Colorado contacted Beynon Sports Surfaces to solve this problem. The solution was Beynon Sports' BSS 2000 Resurfacing System with our embedded texture. The new BSS 2000 Resurfacing System provided a surface ideally suited to the University of Colorado's track and field program. Since installation, the previous joint disorders are no longer experienced.



GILLIS FIELDHOUSE AT THE U.S. MILITARY ACADEMY AT WEST POINT

The U.S. Military Academy had a problem: Their rolled rubber fieldhouse surface was hard, brittle and fading. Beynon Sports' TUNED BSS 2000 Resurfacing System was the answer. After test patches to determine the correct thickness for the desired force reduction were installed, the only decisions left were color and texture. The Academy chose our Hobart Texture™ for the track oval and our spike resistant smooth surface for the basketball and volleyball courts. The TUNED BSS 2000 Resurfacing System provided the U.S. Military Academy at West Point a fieldhouse surface that is both durable for military drill rehearsals and resilient for everyday athletic training and competition.

FULL POUR SYSTEMS

BSS3000

FOCUSSES POWER INTO WINNING

The revolutionary BSS 3000 is IAAF Certified, environmentally friendly, and rapidly improves athletic performance by efficiently converting impact energy into kinetic energy, propelling the athlete forward.

The ultra-soft polyurethane elastomer allows for superior shock absorption for better performance. Additionally, by using only renewable polyol technologies, we reduce the release of carbon dioxide into the atmosphere by 300,000 pounds upon installation.

The BSS 3000 is unlike any sports surface in the market today and unlike other full pour track surfaces, the BSS 3000 contains no SBR. Extensive R&D efforts and rigorous testing have combined to deliver this remarkable advancement in track and field surfacing.

The force reduction layer provides superior shock absorbing properties controlled by an innovative solid gel polyurethane formulation.

Extensive research and development has led to better performance and faster times by efficiently converting impact energy into kinetic energy.

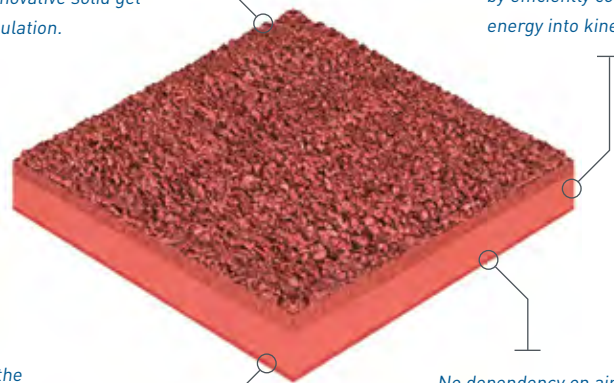

More than 40% of the polyurethane material is derived from a renewable source.

No dependency on air (foam) for shock absorption. Shock-absorbing properties are controlled by the innovative solid gel polyurethane formulation.



BSS2000

THE ULTIMATE EDGE IN WORLD-CLASS PERFORMANCE

The Olympic-caliber BSS 2000 is IAAF Certified and offers athletes the top level of control and maximum energy return. It makes training more manageable and allows athletes to compete at the highest levels with the best in the world.

Featuring a force reduction layer of butyl rubber and full-depth color polyurethane, this system is finished with a customized surface engineered to meet the intense demands of competition.

EPDM granules are mixed throughout the wear layer with your choice of embedded or encapsulated textures to give your athletes superior traction and complete control.

The force reduction layer is constructed with butyl rubber and environmentally friendly polyurethane for maximum energy return.

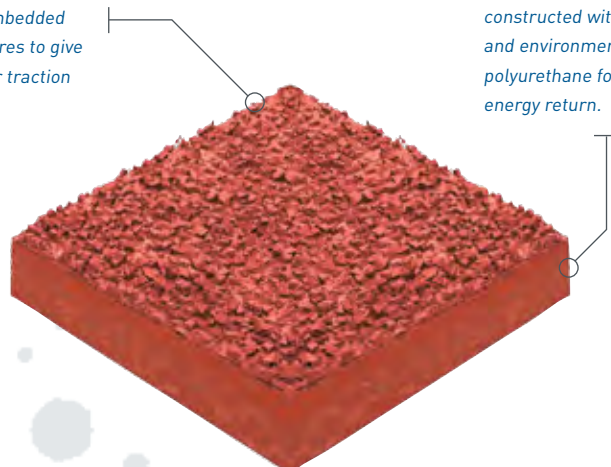

FULL POUR SYSTEMS

BSS1000

THE SURFACE THAT LETS YOUR ATHLETES PUSH THEIR PERFORMANCE TO THE LIMIT

The BSS 1000 is an IAAF Certified surface that allows athletes to give it their all while training or in competition. This surface is durable enough to resist the roughest weather and the toughest competition.

Its bio-engineered force reduction layer integrates very fine SBR rubber granules with environmentally friendly polyurethane to create an impermeable shock-absorbing cushion.



Sharp, precise markings and a seamless surface make this system ideal for world-class competitions.

Choose between embedded, encapsulated, or Beynon's specialized Hobart Texture™.

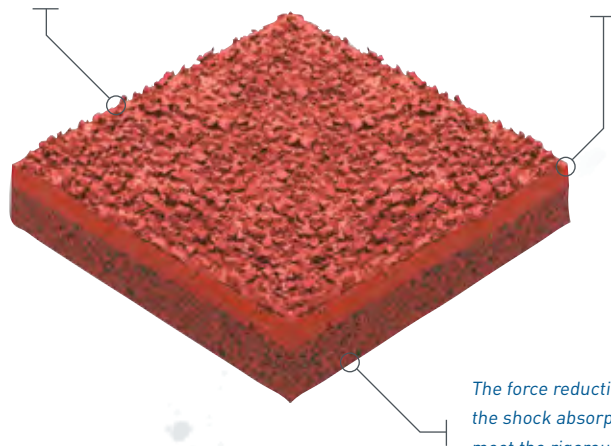

The force reduction layer provides the shock absorption necessary to meet the rigorous demands of the IAAF performance specifications.

BSS1000ML

SURFACES TO DO YOUR BEST BY BEATING YOUR BEST

The BSS 1000ML is an IAAF Certified full pour multilayered track and field surface for schools and universities that desire a full pour track surface to meet competitive bidding requirements.

Made of UV stabilized two-component polyurethane, recycled SBR granules, and EPDM, the BSS 1000ML is a three-layer system that exceeds the requirements of IAAF performance standards.



Choose between embedded, encapsulated, or Beynon's specialized Hobart Texture™.

The force reduction layer is composed of two layers of UV stabilized elastomeric polyurethane and SBR rubber.

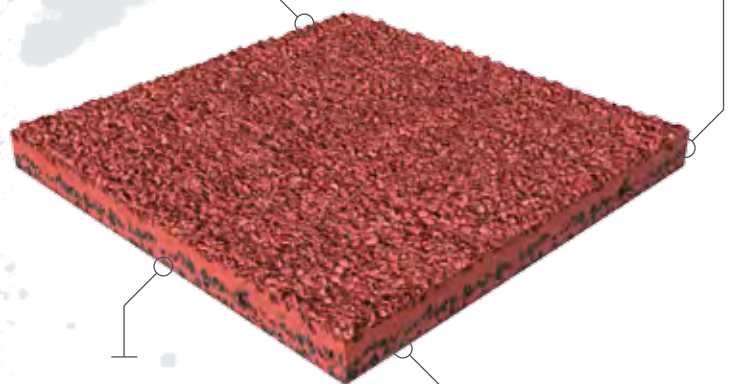

Composed of UV stabilized two-component polyurethane, recycled SBR granules, and EPDM (type of synthetic rubber).

IAAF Certified and backed by an industry-leading five-year warranty.

PAVED SYSTEMS

BSS300

A TRACK SYSTEM AS TOUGH AND DURABLE AS THOSE WHO RUN ON IT

The IAAF Certified BSS 300 is a durable, all-weather, flood and chip sandwich system with excellent shock absorption and the highest return of energy. It's impermeable, resilient, and fast and can take on anything that comes its way.

The Dual Durometer Sandwich system features paved-in-place polyurethane, topped with a two-component seal coat and finished with a flow-applied layer of two-component polyurethane and your choice of texture. The two-component wear layer provides the ultimate return of energy and ensures the longest life cycle in the industry.



Your choice of an embedded or encapsulated texture is applied, providing all-weather usage and minimizing granule migration.

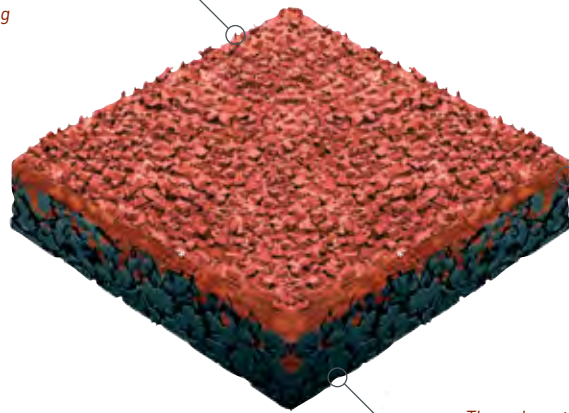

The paved-in-place installation process creates a uniform monolithic surface.

The polyurethane bound, black rubber basemat provides optimum shock absorption.

BSS200

A TRACK SYSTEM THAT STANDS STRONG NO MATTER THE ELEMENTS

You get the most out of the BSS 200 because it allows for safe, long-term training while providing a premier surface to meet virtually every level of competition. You'll get the optimal performance from your athletes for years to come with its ability to withstand most weather climates and conditions.

We start with a paved-in-place polyurethane basemat, then it's coated with a two-component polyurethane sealer to make the surface impermeable.

This track delivers consistent energy return throughout its lifespan.



A spray-applied top layer of EPDM granules and single-component polyurethane creates an all-weather surface, free of granule migration.

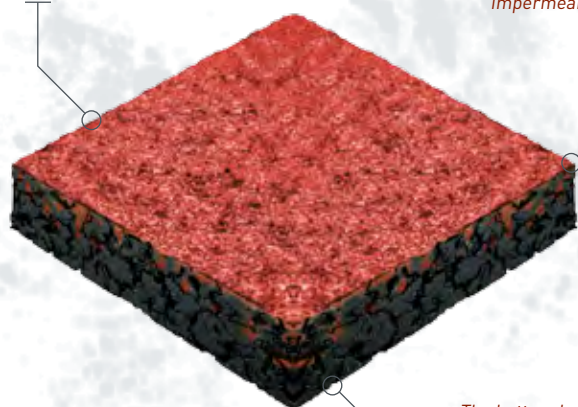

A two-component polyurethane seal coat is applied for an impermeable surface.

The bottom layer combines a polyurethane binder and SBR granules to achieve optimal comfort and shock absorption.

PAVED SYSTEMS

BSS100

THE IAAF CERTIFIED BSS 100 HAS AN EXTENSIVE HISTORY OF LONGEVITY

This surface stands up to all weather conditions and satisfies multi-use needs. It delivers consistent energy return throughout its life cycle and is water permeable.

The BSS 100 is a paved-in-place porous track with a single-compound polyurethane binder and SBR rubber granules, finished with multiple sprays of 100% solids, pigment polyurethane, and EPDM granules.



The surface is sprayed multiple times with pigmented polyurethane and EPDM granules for texture and traction.

SBR rubber granules are paved in place with resilient polyurethane to form the shock-absorbing base layer.

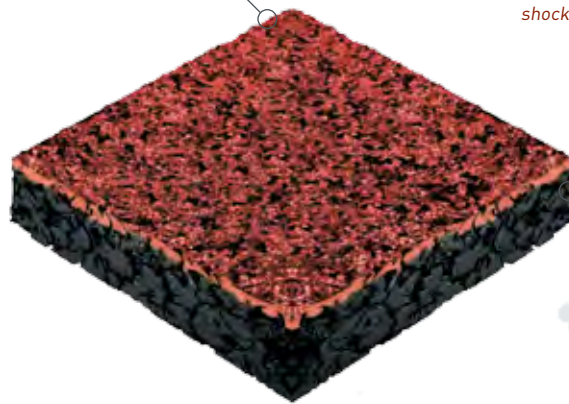

YOUR CHOICE OF TEXTURE

For an Olympic-caliber track, you can finish your surface with your choice of embedded granules, encapsulated granules, or our state-of-the-art Hobart Texture™. These textures are as unique as they are functional. We listened to your needs and developed unique surface textures that can be found on the finest track and field facilities across the United States and around the globe.

These customized textures can be utilized with our BSS 300, 1000, 1000ML, 2000, and 3000 systems and are strong enough to stand up to the sun, rain, snow, and heavy loads.



Embedded



Encapsulated

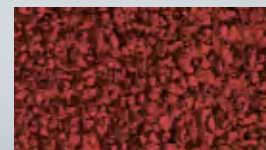

Hobart

BREATHE NEW LIFE INTO YOUR EXISTING SURFACE

Resurfacing your track and field system through Beynon Sports can extend the life of your existing track by 10 to 15 years at a fraction of the cost of replacement. Beynon Sports specializes in the resurfacing of existing track and field facilities. Our resurfacing systems make older, worn, hard sheet good and polyurethane systems brand new. We can also adjust the force reduction to make the surface more user-friendly for daily training and competition.

Beynon Sports has developed a formulated polyurethane primer specifically to adhere to all existing track and field surfaces to allow for full chemical adhesion of the new resurfacing system. Due to the complex nature of UV degradation, an existing track and field surface undergoes chemical changes that present a challenge for any other

company to achieve substantial bond, but because of our understanding of the chemistry, and more than 15 years of extensive research and development, we can guarantee that the chemical bond is obtained.

In order to ensure a lasting surface and bond, the adhesion level needs to be at a minimum of 300 psi. Our research shows that the use of our specially formulated polyurethane primer in conjunction with the new polyurethane resurfacing system will achieve levels greater than 400 psi. Tests of our competitors' resurfacing products have shown adhesion levels of less than 50 psi. With our history and research of resurfacing track and field systems, only Beynon Sports can guarantee full and proper adhesion.

TRACK RESURFACING OPTIONS

We offer the following types of resurfacing systems: 3mm+5mm, 2mm+5mm, and 5mm.

This means we first apply a 2mm or 3mm force reduction layer to improve the feel under foot and correct surface irregularities or minor planarity issues with the existing track and field surface. Once complete, we apply our 5mm resurfacing system with your choice of embedded, encapsulated, or Hobart Texture™.



Embedded



Encapsulated



Hobart

INDOOR PRODUCTS

POLYTURF

KEEPS GOING STRONG
SEASON AFTER SEASON

PolyTurf is a two-component, poured-in-place polyurethane system that offers maximum durability with minimal maintenance.

This seamless surface resists UV degradation and stains and endures the daily use from tables, chairs, and rolling loads—all while providing superior athletic performance. You get the best of both worlds: high resiliency and enduring toughness.

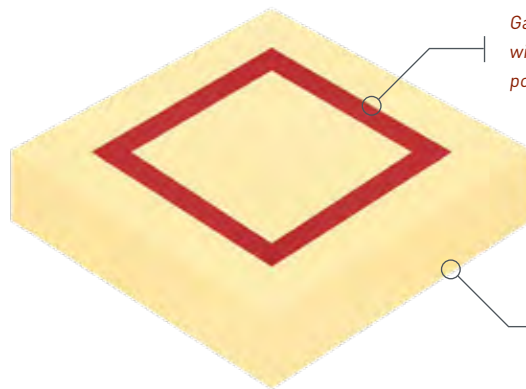

Game lines are meticulously applied with chemically bonded pigmented polyurethane marking paint.

Seamless, self-leveling construction ensures a resilient playing surface.

POLYTURF PLUS DUAL-DUROMETER SYSTEM

SURFACES THAT TAKE
WINNERS TO THE NEXT LEVEL

PolyTurf Plus features a bio-engineered force reduction layer beneath the PolyTurf wear layer to increase return of energy and shock absorbency—taking your sports surface to the next level of performance.

PolyTurf Plus' resilient wear layer is tough enough to endure the extreme demands of daily training and competition, and withstands the abuse of tables, chairs, and rolling loads.

The combination of outstanding athletic performance and rugged durability make PolyTurf Plus a low maintenance and long lifecycle investment that will go the distance for your team.

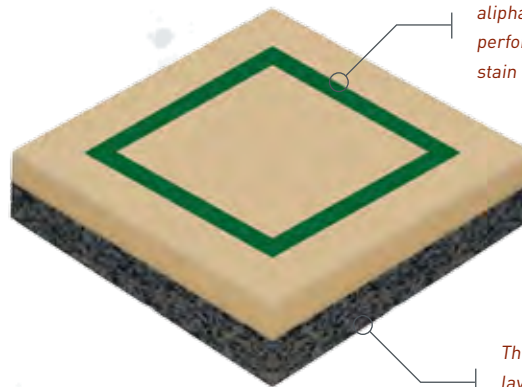

A spray-applied, water-based aliphatic coating provides optimal performance characteristics and stain resistance.

The bioengineered force reduction layer is achieved through seamless self-leveling construction.

POLYTURF PLUS PAD & POUR

CUSTOMIZE TO PERFORM
UNLIKE ANY OTHER

With the PolyTurf Plus Pad & Pour, you can customize your flooring to fit your facility's needs.

Choose from a variety of shock pad thicknesses to achieve your desired training and competing characteristics. We then top it with our two-component polyurethane choke coat layer and self-leveling polyurethane wear coat layer for long-lasting durability.

Our water-based polyurethane finish—in your choice of colors, textures, and thicknesses—ensures easy maintenance and outstanding physical properties.

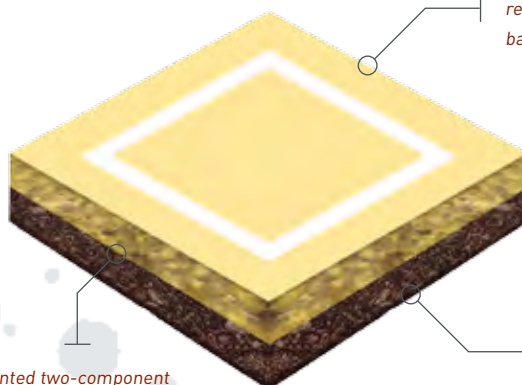

Specifically formulated elastomeric resin gives the surface exceptional ball rebound and durability.

A patented two-component choke coat layer seals the shock pad's pores.

Polyurethane adhesive bonds pad to substrate.

BSS1000 WITH HOBART TEXTURE™

CREATED BY WINNERS
BUILT FOR CHAMPIONS

Found in some of today's most prestigious fieldhouses, the BSS 1000 with our Hobart Texture™ is ideal for multi-function arenas. This dual-durometer, IAAF Certified surface is completely spike resistant and provides exceptional shock absorption and return of energy.

Additionally, the stain-resistant coating is durable enough to resist the toughest competition and requires no advanced maintenance.

Can be designed, manufactured, and installed at a thickness of 10mm and IAAF Certified at 13mm.

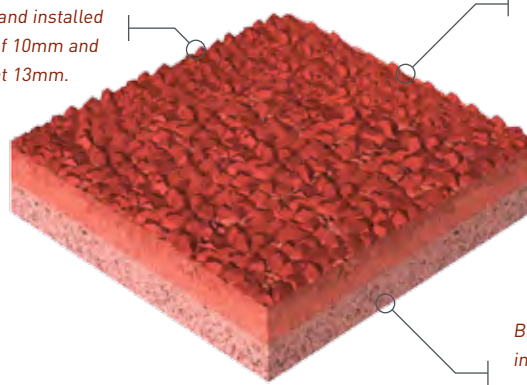

Tuned to the precise durometer required to meet and exceed the needs of your coaching staff, athletes, and facility managers.

Bioengineered force reduction layer integrates very fine SBR rubber granules with environmentally friendly polyurethane.

POLYTURF SP

THE SPIKE-RESISTANT SURFACE
YOUR FACILITY DESERVES

The PolyTurf SP system is a smooth surface that utilizes revolutionary BEYPUR 500 technology to provide a non-textured surface that repels the wear and indentation of spikes.

The PolyTurf SP system can feature a bioengineered force reduction layer or a prefabricated polyurethane-bound pad beneath our proprietary polyurethane wear layer to increase return of energy and shock absorbency.

The BEYPUR 500 polyurethane wear layer provides a seamless spike-resistant surface with unparalleled performance characteristics. PolyTurf SP's resilient wear layers are tough enough to endure the extreme demands of daily training and competition—as well as the abuse of tables, chairs, and rolling loads.

The teaming of superior performance and rugged durability makes the PolyTurf SP a low maintenance, long-lasting investment that will go the distance for your organization.

The BEYPUR 500 polyurethane wear layer provides a seamless spike-resistant surface with unparalleled performance.

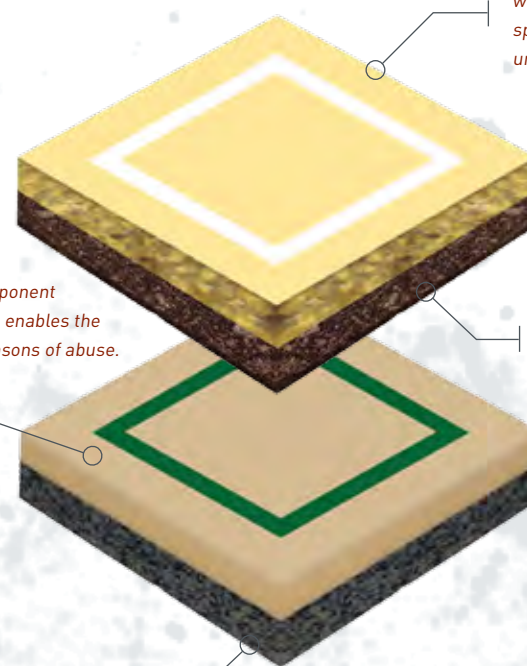

A full-depth two-component elastomeric urethane enables the surface to endure seasons of abuse.

The shock pad is pre-manufactured using 100% recycled rubber and polyurethane binder.

Chemical/mechanical bond to the substrate

WE ARE A **LEADER** IN ENVIRONMENTAL AWARENESS

Beynon Sports is committed to exceeding environmental standards, which is why we lead the industry in research and development. We bring our clients the most environmentally friendly products available by using natural-based compounds and renewable resources and utilizing no hazardous materials from our formulations.

Our eco-friendly components and research and development initiatives include:

- **CONCRETE PRIMER** — High Solids, Zero VOC primer utilizing renewable, natural-based raw materials.
- **100% SOLIDS 1-C SPRAY** — Beynon Sports is the only manufacturer to supply a 100% solids single-component structural spray, thus eliminating exposure to solvents.
- **ISOCYANATE-FREE WATERBORNE POLYURETHANE 1-C SPRAY** — Beynon Sports is the only manufacturer to provide a non-isocyanate based polyurethane single-component structural spray.
- **BEYPUR 250** — Two-component polyurethane wear layer material utilizing more than 45% renewable polyols.
- **WATER-BASED ALIPHATIC COATING** — Odorless and solvent-free coatings for gymnasium, fieldhouse, and outdoor track systems.

- **2-C URETHANES** — 100% Solids, zero VOCs and formulated without heavy metals to create an eco-friendly and non-hazardous system.

- **LEED® CERTIFICATION** — Beynon Sports' entire product suite is eligible for LEED Credits. LEED is a rating system developed by the U.S. Green Building Council to set a benchmark for the design, construction, and operation of high-performance green facilities. Our indoor product line was designed specifically for this market.



It is the mission of Beynon Sports to exceed the expectations of our customers through the formulation, production, distribution, and installation of safe, environmentally friendly athletic surfaces designed for speed, resiliency, and daily use in athletic facilities around the world. To increase awareness and maintain our leadership position as innovators in the industry, Beynon Sports is actively involved in green-focused organizations.

A WARRANTY THAT OUTLASTS ALL OTHERS



Beynon Sports offers the strongest warranty in the industry and we back it up.

Our comprehensive five-year warranty on all track and field surfaces or our all-inclusive 10-year warranty on select BSS 1000ML, BSS 1000, BSS 2000, or BSS 3000 track and field surfaces can also be backed by a third-party insured warranty for a coterminous five-year or eight-year period. Beynon Sports maintains a prepaid zero-deductible product defect insurance policy with no limit per claim, no retention, and no retention period based on our significant capital surplus and reserve funds.

FEATURED INSTALLATIONS

UNIVERSITY OF OREGON, HAYWARD FIELD



The University of Oregon's Hayward Field required an Olympic-caliber track and field system to meet the needs of the U.S. Olympic Trials, annual Prefontaine Meet, and the NCAA Championships. To ensure Hayward Field received the best track and field surface available, the U.S. Olympic Committee, Nike®, and USA Track & Field evaluated all track and field surfacing systems and interviewed athletes, coaches, and designers from around the world. Their conclusion was that only Beynon Sports' IAAF Certified Class I, BSS 2000 system with

embedded texture could provide the surface necessary to propel their athletes into the Olympics at record-setting times. As validation of their choice, at the 2012 U.S. Olympic Trials, the American, collegiate, high school, American junior, and world junior records in the 100 meters were all set on their BSS 2000 track surface. The performances at the University of Oregon have proven, once again, that competing on Beynon Sports' polyurethane surfaces is preferred by the world's best athletes.

“Thank you for your personal attention to the myriad details associated with building the competition venues at Hayward Field. It was a fantastic success and you and your staff played pivotal roles in that outcome. I appreciate your willingness to respond to our specific and unique needs for Hayward Field.”

— Vin Lananna
ASSOCIATE ATHLETIC DIRECTOR,
UNIVERSITY OF OREGON



FEATURED INSTALLATIONS

SPIRE INSTITUTE, GENEVA, OHIO



The SPIRE Institute is one of the largest indoor and outdoor track and field complexes in the Midwest. It is world renowned for being one of the fastest indoor track and field facilities in the country—records are steadily broken at the high school, collegiate, and professional levels. At any given time, the area can host two long jumps, two pole vaults, two high jumps, and three shot puts while running the gamut of races.

The SPIRE Institute features an eight-lane 300 meter indoor track using Beynon Sports' BSS 1000 surface with Hobart Texture™ as well as various basketball and volleyball courts utilizing Beynon Sports' PolyTurf sports surface. Outdoors the SPIRE Institute boasts Beynon Sports' BSS 2000 surface with embedded texture, providing athletes with multiple high-performance sports surfaces for training and competition.

“The NAIA is looking forward to having the SPIRE Sports Complex host our Indoor Track & Field National Championships for the next two years. This organization oversees world-class facilities and will offer our student-athletes, coaches, and fans a truly memorable experience. We are excited to nationally showcase the best track and field athletes in Geneva, Ohio.”

— Jim Carr
NAIA PRESIDENT AND CEO

UNIVERSITY OF WASHINGTON



When the University of Washington chose to build a world-class track and field facility on a concrete subbase supported by dozens of perfectly engineered piers, they needed a sports surfacing manufacturer and installer that could handle the challenges and provide them with a surface of unmatched quality and performance.

After an extensive and comprehensive evaluation process, the Huskies selected Beynon Sports' BSS 2000 track and field surface with the specialized Hobart Texture™.

With more than 160 installations throughout the NCAA Division I, II, and III combined with eight IAAF Certified surfaces to choose from, only Beynon had the expertise and qualifications to provide the Huskies with the surface they needed. Completed in October 2012, the track rewards athletes with the maximum energy return required to shatter records.

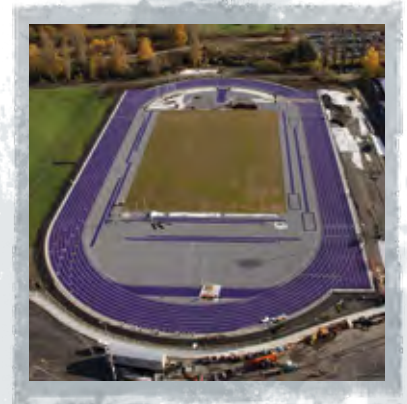

FEATURED INSTALLATIONS

UNIVERSITY OF ALABAMA, SAM BAILEY TRACK AND FIELD STADIUM



In 2006 the Crimson Tide needed to resurface some of their runways and opted to go with Beynon. A few years later, when the time came to replace Sam Bailey Track and Field Stadium's entire running surface, the choice was clear—Beynon Sports. This was due to our unmatched quality of products and expertise in multicolor polyurethane surfaces, as well as superior

customer care. The University of Alabama selected Beynon Sports' IAAF Certified BSS 2000 track surface with embedded texture with a unique design featuring wider turns that resulted in faster times. Finished in November 2012, the BSS 2000 track and field surface will provide one of the best surfaces in the world for speed as well as distance events.

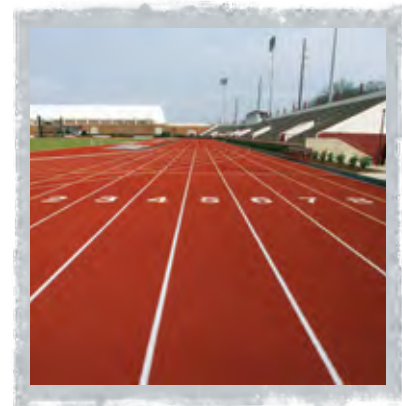

UNIVERSITY OF KENTUCKY, SHIVELY TRACK COMPLEX



The track and field surface at the University of Kentucky had become worn and a challenge for hosting competitive NCAA meets. Rather than simply trying to renovate their existing track facility, the University of Kentucky selected Beynon Sports to build a new facility utilizing both our IAAF Certified BSS 2000 and BSS 3000 track and field surfaces. Beynon Sports was the general contractor for the entire project, managing not only the track surfacing but also the

concrete curbs, slot drains, asphalt, and subbase. Handling this larger scope of work was no small task, but with full site contracting capabilities, it is one Beynon Sports was prepared for. With a résumé that includes construction of multiple IAAF Class I facilities in the United States, Beynon Sports' construction expertise and outstanding customer service were the clear choice for the University of Kentucky.



FEATURED INSTALLATIONS

LIBERTY UNIVERSITY, MATTHES-HOPKINS TRACK COMPLEX



As of 2013, six of the 15 Big South Men's and Women's Outdoor Track and Field Championships have been held at Liberty University, including the inaugural event in 1994. With an impressive list of championships, Liberty University needed a new track and field facility that could exceed the expectations of their coaches,

athletes, and distinguished alumni. Liberty University chose Beynon Sports to manage the entire reconstruction of the Matthes-Hopkins Track Complex from facility design to site contracting to installation of their new BSS 1000 track and field surface with Hobart Texture™.



BUCKNELL UNIVERSITY, CHRISTY MATHEWSON MEMORIAL STADIUM

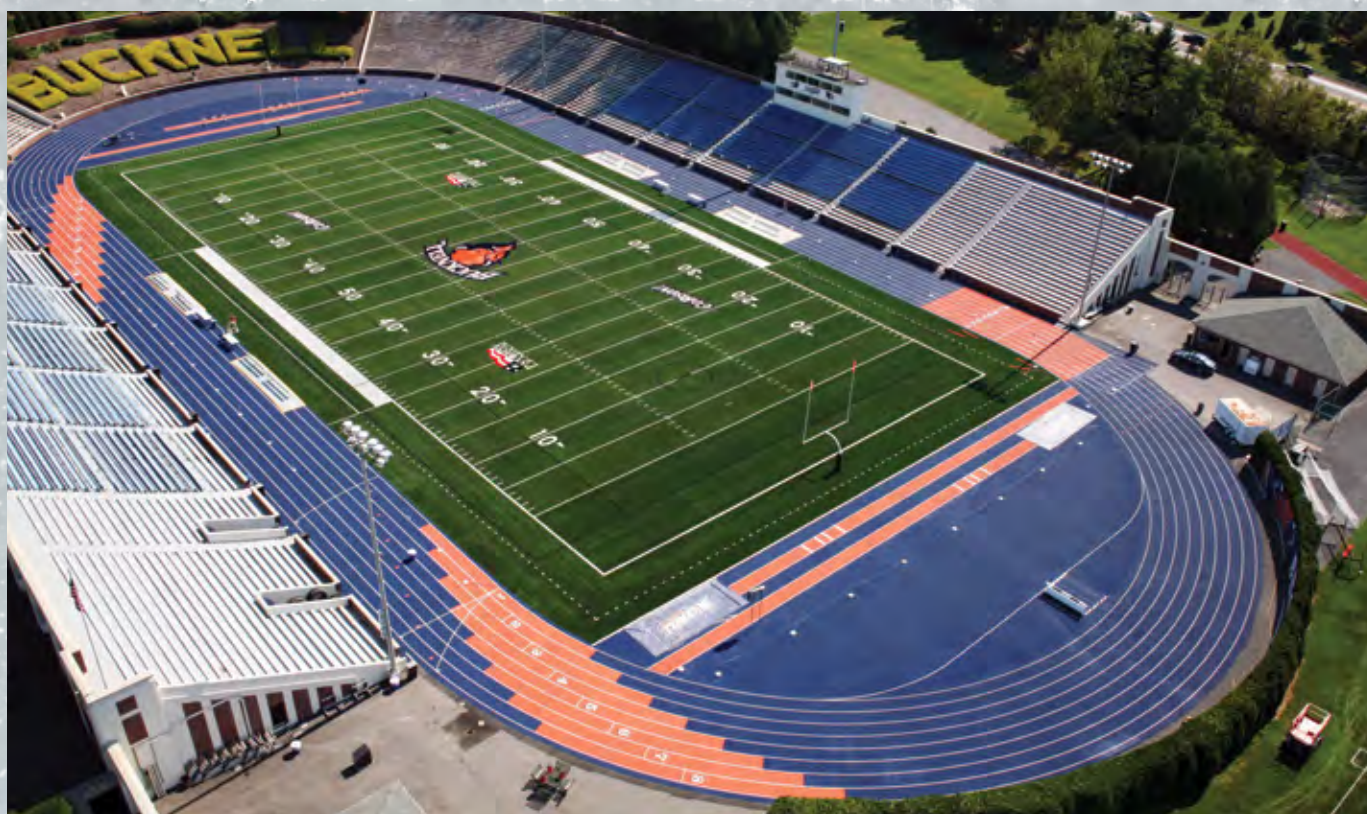

Bucknell University and Beynon Sports extended their long partnership when the Bison elected to go with Beynon Sports' BSS 2000 with Hobart Texture™ for the renovation of the Christy Mathewson Memorial Stadium. Beynon Sports' history of great customer service and exceptional products made the decision to remain with Beynon an easy choice.

This marks the fifth time that Bucknell University has selected Beynon Sports to design, manufacture, and install their athletic surfaces on campus. With Bucknell University's Gerhard Fieldhouse also utilizing a Beynon surface, the Bison can train and compete on Beynon Sports' surfaces year-round.

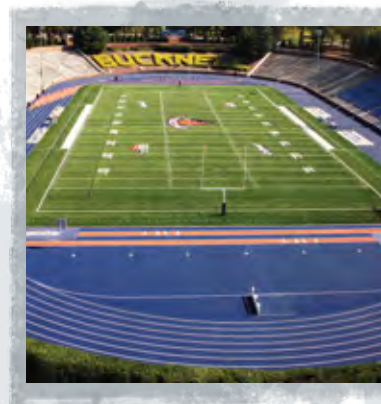



BEYNON[®]
A Tarkett Sports Company

16 ALT ROAD | HUNT VALLEY, MARYLAND 21030 | 410.771.9473 | WWW.BEYNONSPORTS.COM

About Beynon Sports:

Beynon Sports was founded by John T. Beynon with the vision of creating the highest performing synthetic surfaces designed for speed and competition, as well as daily training. Beynon's premier IAAF-Certified track and field surfaces, GreenGuard-certified indoor fieldhouse and gymnasium surfaces and outdoor tennis courts are found in the world's most renowned athletic facilities.

In the spring of 2008, Beynon Sports joined the Tarkett Sports family, combining the most recognized and prestigious name in the artificial turf market in FieldTurf with the celebrated Beynon Sports' branded track and field, fieldhouse and gymnasium surfacing systems. The result is a global firm with unmatched financial strength and a dedication to innovation, customer service, and excellence. Through this partnership, clients receive unprecedented service, quality, and support as well as the financial backing to stand behind the products manufactured and installed.

Beynon Sports is part of Tarkett Sports, a Division of the Tarkett Group. Tarkett Sports is the largest entity in the sports and landscape surfacing industries. Included within the Tarkett Sports portfolio is the world-renowned FieldTurf brand of artificial turf along with an impressive range of performance sports flooring products. This product range includes: synthetic and hardwood basketball; volleyball and gymnasium flooring; squash and racquetball courts; floor protection and covering systems; weight room flooring; and high performance indoor and outdoor running tracks. All Tarkett Sports surfaces are developed, produced and installed with a concentration on sustainability and a commitment to protecting the environment, providing additional LEED contribution opportunities for customers. The company calls this focus on sustainability and the environment 'Environmental Intelligence' and all company personnel strive to exemplify this philosophy in all aspects of the business.

Key Talking Points:

- Industry leader in the design, formulation, production and installation of outdoor track and field, and indoor fieldhouse and gymnasium polyurethane surfaces for high schools, universities and international arenas
- Over 1,500 installations worldwide in the past ten (10) years with over 40 years' experience in the renovation and new construction of sports facilities
- Manufacture over thirty-seven (37) unique polyurethane components for the indoor and outdoor sports surfacing market
- Go to market using a direct installation model, where Beynon Sports' own employees physically construct the surface on-site
- Core markets are North America, Caribbean and Southeast Asia with early-stage share development in India, South America and the European Union

Culture of Beynon Sports:

With the spirit of a start-up and the depth and stability of an industry powerhouse, Beynon Sports provides its employees with the autonomy to execute their objectives in a truly entrepreneurial environment, the resources to master their tasks and the purpose to understand how the effective execution of each individual's responsibilities represents a critical part of the success of the organization.

At Beynon Sports, our team members are dedicated to four core principles:

- **Commitment to the Customer**, which simply means doing what we say we will do.
- **Focus on Financial Strength** to create long-term sustainability. This requires an ever-vigilant focus on cost control, maintenance or expansion of operating margins and avoidance of unquantifiable risks.
- **An Unwavering Emphasis on Operational Excellence** in all aspects of our business – from product formulation to production from estimating to contract management and from construction to close-out.
- **Dedication to the Employee**, which means diligently executing each of our duties thoroughly and conscientiously and the company, in turn, providing fair compensation and benefits and opportunities for career growth and a promoting a healthy balance between our personal and professional lives.

Ownership and Structure:

- Founded in 2001 by John T. Beynon
- Acquired by Tarkett in April 2008
- Beynon is a Division of Tarkett Sports

Approximate Annual Revenues and Number of Employees:

- \$85M USD per year
- 300 employees in the Peak Summer Months

What is the Address of our Headquarters and ISO-9001 Manufacturing Center?

- 16 Alt Road, Hunt Valley, Maryland 21030 (410) 771-9473
Main Contact: Mark Scrivano

Where are Our Operational Centers Located?

- 350 CR 255, Georgetown, Texas 78633
(512) 778-6170
Main Contact: Rick Ediger
- 19600 SW 129th Avenue, Tualatin, Oregon 97062
(503) 563-6396
Main Contact: Rob Gloeckner
- 4263 N Selland Ave, Fresno, California 93722
(559) 840-1585
Main Contact: Mason Farnsworth
- 775 Canosa Ct., Denver, Colorado 80204 (Renner Sports)
(303) 825-3435
Main Contact: Greg McKenna

How Many Installation Teams Do We Have?

- Twenty-four (24) Installation Teams

How Many Regional Sales Offices Do We Have?

- Fourteen (14) Regional Sales Offices Across the United States

How Many Tracks and Fieldhouses Do We Build Each Year?

- Between 180 and 225 facilities each Year Across North America at close to 10.0M square feet of surfacing.
- Including our Partners in the Northeast, close to 275 clients select a Beynon surface each year.

Why Do We Use Distributors in the Northeast?

Due to the increased seasonality in the Northeast, a mature and established market, and the requirement for a Union-designated workforce, Beynon Sports partners with contractors dedicated to the same ideals and levels of workmanship and client satisfaction.

Key Competitive Advantages of Beynon:

- Manufacturer and Installer – Single Source Provider and Warranty.
- Third-Party Insured Warranty on All Projects (Only Track Manufacturer and Installer who can provide this).
- Bonding Capacity.
 - Ability to bond a single project up to \$20,000,000
 - Aggregate bonding capacity at \$75,000,000
- Seven (7) IAAF Certified Systems – Solution to Meet Any Budget
- Customization.
 - All surfaces are designed, manufactured and installed to the precise durometer and force reduction desired
 - All polyurethane products are made in Hunt Valley, Maryland, USA
- Leading Builder in North America with >50% Market Share.
- Access to SmartBuy Cooperative Purchasing.

Why is SmartBuy such a Great Tool for the Client?

- Control: Get the Beynon surface you want without leaving anything to chance.
- Speed: No purchasing process is faster from proposal-> contract. Period.
- Simplicity: Single contract, sole-source responsibility, no General Contracting mark-up.
- Value: Secure the team, schedule and terms of your choosing.
- Savings: Time, energy and confusion of the bid process is greatly reduced.

- [Plexipave Products](#)
- [Plexicushion Products](#)
- [Component Products](#)
- [Selecting a Surface](#)
- [Tennis Court Colorizer](#)
- [Court Maintenance](#)
- [Court Resurfacing](#)
- [Reference Sites](#)
- [Tennis Specs / MSDS](#)

Plexipave Tennis Court Surface Products



[Open Plexipave Color Card](#)

"As the USC men's tennis coach for the past 23 years, I was always looking for a slow, long-lasting court surface. Plexipave was the answer! They also have brilliant colors that stay sharp."

Dick Leach Retired Men's Tennis Coach
University of Southern California

"I think it's great for the body. I think it's good for anyone's body. It's a lot easier on the joints, which is always good, especially when you're 6-2."

Maria Sharapova
Professional Tennis Player From the New York Times, article "Australian Open Evens the Playing Surfaces" published Jan 13, 2008

Plexipave systems are formulated to meet the requirements of players at any level. For **tennis court surfaces**, there are three systems to choose from, offering varying degrees of speed and playability, all rated by the governing body of the game, the International Tennis Federation (ITF).

Plexipave IW - ITF Category 1 - Pace: Slow

For those who desire a much slower surface, to compensate for lower humidity, high altitudes or simply to change the pace of the game, Plexipave has developed the I.W. mixture, first used at the Indian Wells, CA tournament facility.

Plexipave Standard - ITF Category 3 - Pace: Medium

Considered by many to be the best combination of consistency-of-play, pace and footing. Plexipave Standard is the traditional and most widely used tennis court surface system. Standard Plexipave provides a consistent and reliable medium-pace playing surface.

Plexipave H.U. - ITF Category 4 - Pace: Medium-Fast

Harvard University has been the birthplace of many great innovations and playing traditions. Plexipave H.U. is no exception. It has also been adapted as the standard for the Australian Open Series.

The Plexipave Color Finish System is an all-weather, durable, quick drying color surface that provides superior resistance to deterioration from ultra-violet rays. Plexipave is a 100% acrylic latex, color intense tennis surface formulated for use over asphalt and concrete. The high performance finish coat is available in ten popular standard colors. Custom colors are available to meet individual needs. Plexipave has been the choice of tournament installations around the world.

Plexipave - Plexipave

[\[Back to top \]](#)

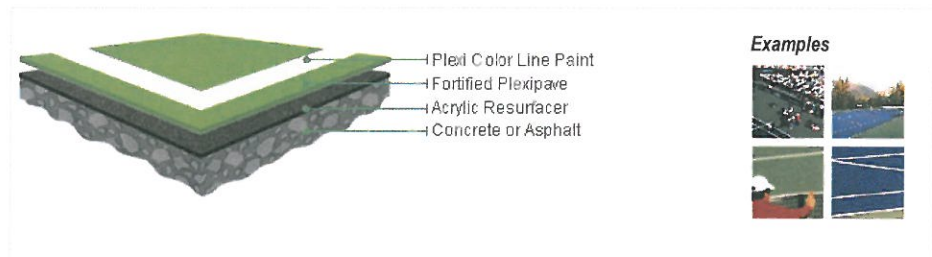

Plexipave

© 2014

California Products, Inc., All rights reserved | [Site Map](#)



- [Plexipave Products](#)
- [Plexicushion Products](#)
- [Component Products](#)
- [Selecting a Surface](#)
- [Tennis Court Colorizer](#)
- [Court Maintenance](#)
- [Court Resurfacing](#)
- [Reference Sites](#)
- [Tennis Specs / MSDS](#)



[Open Plexipave Color Card](#)

"As the USC men's tennis coach for the past 23 years, I was always looking for a slow, long-lasting court surface. Plexipave was the answer! They also have brilliant colors that stay sharp."

Dick Leach Retired Men's Tennis Coach
University of Southern California

"I think it's great for the body. I think it's good for anyone's body. It's a lot easier on the joints, which is always good, especially when you're 6-2."

Maria Sharapova
Professional Tennis Player From the New York Times, article "Australian Open Evens the Playing Surfaces" published Jan 13, 2008

Plexipave and Plexicushion Tennis Court Surfaces

Advanced acrylic tennis surface systems for indoor and outdoor tennis facilities

Plexipave and Plexicushion systems are advanced tennis surfacing systems designed to provide players with the highest levels of surface performance for competition and cushioning for safe training.

The **Plexipave** Color Finish system is an all-weather, durable quick-drying color surfacer that provides superior resistance to deterioration from ultra-violet rays. Plexipave is a 100% acrylic latex color intense sports surface formulated for use over asphalt and concrete.

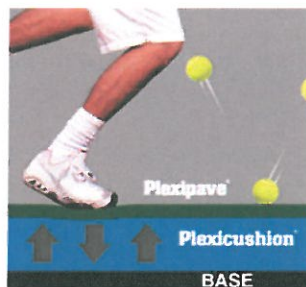

The **Plexicushion System** combines the consistent bounce, sure footing and outstanding durability of Plexipave with the innovative, shock-absorbing properties of EPDM rubber cushioning. The result is a tennis surface that dynamically responds to body impact and reduces fatigue on legs, knees, ankles and feet.

The Plexicushion substrate, a special blend of latex, rubber and plastic particles forms a resilient layer that absorbs body shock and reduces muscle fatigue. The 100% acrylic Plexipave surface provides uniform bounce, long lasting color and allows speed of play specification.

System Components Plexipave and Plexicushion are engineered tennis surface systems made up of innovative materials installed according to rigid application specifications. Each layer in the system serves a specific purpose, and contributes to the quality of the finished court.

- Textured line paint insures uniform ball bounce.
- Highly pigmented finishes allow speed of play specification. (Available in a popular palette of colors)
- Multiple Plexipave acrylic layers for the firm, uniform and durable surface Plexipave and Plexicushion are noted for.
- Plexicushion is an enhancement that provides dynamic response to body impact, attenuates foot and leg shock, and reduces fatigue.
- A filler undercoat.
- The Systems can be installed indoors or outdoors, on asphalt or concrete.
- Additional Plexipave products are used for patching, leveling and etching base surfaces.

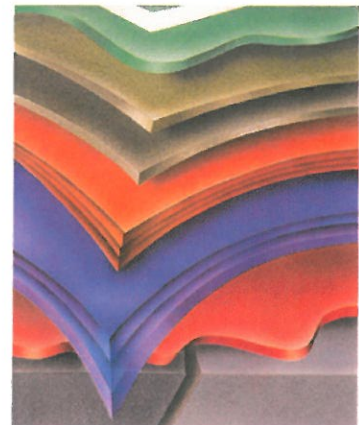

Durability and Value Worldwide

Owners and facility managers around the world appreciate Plexipave's long-lasting, all-weather durability. It's 100% acrylic, asbestos-free composition retains color, texture and playability for 5 to 7 years between resurfacings. Excellent wear resistance represents significant value: a Plexipave or Plexicushion court is a wise investment that yields substantial returns year after year.

Outstanding Service and Support

Plexipave and Plexicushion are the most widely used acrylic tennis court surfacing systems in the world. They have achieved a global presence in tennis surface systems, and enjoy an international reputation for excellence and dependability. With the Plexipave and Plexicushion Systems, you get superior products supported by a worldwide organization of authorized applicators.

Superior Playability

Tennis players everywhere attest to the superior playability of the Plexipave System. Plexipave's speed of play makes it possible for all types of players to excel, and its distinctive qualities of consistently true bounce and sure footing enhance coaching, training and competition. According to coaches, when tournament competitors play on Plexipave and Plexicushion, they are unhindered by surface inconsistencies, allowing a level of play which truly reflects the athlete's skill.



**COPELAND COATING
COMPANY, INC.**



ACTION-PAVE®
ATHLETIC SURFACES

ACTION PAVE CUSHION AND SUPER CUSHION

DESCRIPTION -

ACTION PAVE CUSHION is a highly resilient, rubberized coating consisting of encapsulated rubber particles and fillers, blended with 100% acrylic emulsion to provide a resilient, shock absorbing surface. (Three coat application.)

ACTION PAVE SUPER CUSHION is for those who demand only the best. It offers the ultimate in championship caliber resiliency. Formulated with varying gradations of granulated rubber particles suspended in 100% acrylic emulsion, **ACTION PAVE SUPER CUSHION** is super resilient to help reduce foot and leg fatigue, but durable enough to resist impact and gouging. (Five coat gradated rubber application.)

USE -

Apply over new surfaces which have been coated with **ACTION PAVE ACRYLIC RESURFACER** or over previously color coated surfaces which never received a resilient cushion system.

APPLICATION -

Use a standard, commercial quality, squeegee 24", 30" or 36" in width. Clean squeegee with water immediately after use.

MIX DESIGN -

ACTION PAVE CUSHION and **SUPER CUSHION** are concentrated and need to be mixed on site with clean water. Thorough mixing is required. Mortar mixer offers best results.

2 parts **ACTION PAVE CUSHION** or **SUPER CUSHION**
1 part water

COVERAGE -

To surface the standard tennis court (800 square yards) approximately 55 gallons of concentrated **ACTION PAVE CUSHION** or approximately 80 gallons of concentrated **ACTION PAVE SUPER CUSHION** is required. (These quantities are per coat.) The amount of material needed will vary slightly due to variation in density of the asphalt substrate and the technique of application. Approximate coverage ratio = 14 Square yards per gallon of concentrate for **ACTION PAVE CUSHION** and 10 square yards per gallon of concentrate for **ACTION PAVE SUPER CUSHION**.

SURFACE PREPARATION AND APPLICATION -

The surface must be clean and free of grease, oil and any other foreign material.

ACTION PAVE CUSHION (three coat application): Pour a ribbon of material along one end of the area to be surfaced. Spread evenly by walking in one direction and then reversing direction. Always maintain a wet edge and do not overwork material. After thorough drying and before applying the next coat of material, inspect the surface and scrape off any ridges, lumps or other imperfections. Then apply the next coat at a 90° angle to the

Page 1 of 2

3600 Route 20
PO Box 595
Nassau, (Albany area) NY 12123
www.copelandcoating.com



Tel: (518) 766-2932
(800) 303-4219
Fax: (518) 766-3603
E-mail: copeland@albany.net

"The pavement maintenance people...since 1945"

first one.

ACTION PAVE SUPER CUSHION (five coat application): Utilizing the larger gradated rubber particles of the SUPER CUSHION mix for the first three applications of this system, we create a rough rubber texture which is then filled and made uniform with two final coats of regular cushion material. The result is a very durable and highly resilient acrylic underlayment ready for the ACTION PAVE ACRYLIC COLOR SURFACE. Application procedures for this five (5) coat system are the same as for the three (3) coat system on the preceding page.

LIMITATIONS -

- Do not apply ACTION PAVE CUSHION or SUPER CUSHION when surface temperature is below 50°F (10°C) or when fog, rain or high humidity is imminent.
- Do not apply if surface temperature is above 130°F (55°C).
- Do not store in direct sunlight.
- Close cover tightly.
- Keep from freezing.



**COPELAND COATING
COMPANY, INC.**



ACTION-PAVE®
ATHLETIC SURFACES

ACTION PAVE ACRYLIC FINISH COAT

DESCRIPTION -

100% acrylic emulsion, special pigmented prime color reinforcing pigments that provide a super durable, long lasting finish coat to all surfaces. ACTION PAVE ACRYLIC FINISH coat has been specifically engineered to protect the entire ACTION PAVE ATHLETIC SURFACE SYSTEM from the ultraviolet rays of the sun and to cool the surface for more pleasurable play. Unlike other acrylic surfacing finish coats, ACTION PAVE ACRYLIC FINISH is fully pigmented, resulting in longer lasting, richer, full depth color.

USE -

Apply over existing color coated surfaces where no additional texture is needed. Apply over ACTION PAVE ACRYLIC FILLER coat(s) to finish off the ACTION PAVE ATHLETIC SURFACING SYSTEM.

APPLICATION -

Use a standard, commercial quality, squeegee or hair type applying brush 24", 30" or 36" in width. Clean squeegee/brush with water immediately after use.

MIX DESIGN -

ACTION PAVE ACRYLIC FINISH is concentrated and needs to be mixed on site with clean water. Thorough mixing is required. Mortar mixer offers best results.

2 parts ACTION PAVE ACRYLIC FINISH
1 part water

COVERAGE -

To surface the standard tennis court (800 square yards) a one (1) coat application will require 55 gallons of concentrated ACTION PAVE ACRYLIC FINISH. A two (2) coat application will require 95 gallons of concentrated ACTION PAVE ACRYLIC FINISH. Approximate coverage ratio for a one (1) coat application = 15 square yards per gallon of concentrate.

SURFACE PREPARATION AND APPLICATION -

The surface must be clean and free of grease, oil and any other foreign debris. ACTION PAVE ACRYLIC FINISH coat is to be applied over previously color coated or new surfaces which have already received ACTION PAVE ACRYLIC FILLER coat(s).

Spread ACTION PAVE ACRYLIC FINISH coat evenly by walking in one direction and then reversing direction. Always maintain a wet edge and do not overwork the material. Avoid leaving any puddles when squeegeeing material back and forth. Allow materials to dry sufficiently before applying the ACTION PAVE ACRYLIC WHITE LINE PAINT.

LIMITATIONS -

- Do not apply ACTION PAVE ACRYLIC FINISH coat when surface temperature is below 50°F (10°C) or when

Page 1 of 2

3600 US Route 20
PO Box 595
Nassau, (Albany area) NY 12123
www.copelandcoating.com



(518) 766-2932
(800) 303-4219
Fax: (518) 766-3603
E-mail: ActionPave@copelandcoating.com

"The pavement maintenance people...since 1945"



LIMITATIONS (continued) -

fog, rain or high humidity is imminent.

- Do not apply if surface temperature is above 130°F (55°).
- Do not store in direct sunlight.
- Close cover tightly.
- Keep from freezing.

	Medium Green	Dark Green	Red	Blue	Gray	Beige (Sand)	White Line Paint
Non Volatile	30.4%	31.2%	30.5%	30.7%	31.7%	31.5%	47.0%
Volatile	69.6%	68.8%	69.5%	69.3%	68.3%	68.5%	
<i>Non Volatile:</i>							
Chromium Oxide	12.3%	11.9%					
Iron Oxide		2.6%	14.8%	3.0%	2.9%	10.0%	
Silica & Silicates	45.7%	44.5%	44.6%	44.1%	43.2%	44.7%	16.6%
Titanium Dioxide				10.8%	14.6%	6.6%	57.9%
Phthalocyanine Blue				2.1%			
Additives	9.9%	9.7%	9.3%	9.1%	9.0%	8.0%	5.6%
Acrylic Polymer	32.1%	31.3%	31.3%	30.9%	30.3%	30.7%	19.9%
<i>Volatile:</i>							
Alcohols & Glycols	4.9%	4.9%	4.9%	4.9%	4.9%	4.9%	4.9%
Water	95.1%	95.1%	95.1%	95.1%	95.1%	95.1%	94.1%

Dilution Ratio: 55 gallons ACTION PAVE concentrate 0 to 500 pounds sand (dependent upon surface and playing speed desired) 24 to 30 gallons water

Viscosity: Brookfield #6 spindle - 20 RPM 1 1,500 cps. * 2,000 cps. (avg.)

pH: 9.0 * .6 (avg.)



**COPELAND COATING
COMPANY, INC.**



ACTION-PAVE®
ATHLETIC SURFACES

ACTION PAVE ACRYLIC CRACK & LEVELING BINDER PATCH

DESCRIPTION -

A super durable acrylic emulsion mixed on site to repair cracks and level and fill low spots. It is a three (3) component bonding emulsion for correcting major and minor non-structural cracks and can smooth over and temporarily repair structural cracks. It is very effective in filling low spots in 1/4" to 1/2" lifts. Multiple applications will be required to achieve a smooth, surfacable repair.

USE -

After cracks and low spots are thoroughly clean, apply ACTION PAVE ACRYLIC CRACK AND LEVELING BINDER PATCH to the areas of repair. This repair should be done and completed in its entirety before any other ACTION PAVE products are applied.

APPLICATION -

Apply to cracks using a horseshoe squeegee and to low spots using an aluminum straight edge.

MIX DESIGN -

A three (3) component emulsion which is mixed on site using a hand drill or mortar mixer consists of:

- 1 part ACTION PAVE CRACK AND LEVELING BINDER PATCH
- 2 parts dry silica sand (75-100 mesh)
- 1/3 part portland cement

Mix the silica sand and cement thoroughly in a clean mortar mixer or container utilizing a power hand drill. Be sure cement is thoroughly mixed with the silica sand, removing all lumps. Then add ACTION-PAVE CRACK AND LEVELING BINDER PATCH with agitation. Mix until uniform. If the mix is too dry adjust by adding more ACTION PAVE CRACK AND LEVELING BINDER PATCH until a workable consistency is achieved.

NOTE: NEVER ADD WATER.

Upon completion of mixing apply material immediately. Clean up all mixing and application equipment immediately upon completion.

NOTE: MATERIAL SETS UP VERY RAPIDLY.

COVERAGE -

Approximately six square feet per gallon of mixed emulsion at 1/4" depth. Approximately five linear feet per gallon of mixed emulsion at 1/2" width X 1/2" to 3/4" depth.

SURFACE PREPARATION AND APPLICATION-

The surface for low spot patching must be clean and free of all dirt, debris and any film or mildew which may

Page 1 of 2

3600 US Route 20
PO Box 595
Nassau, (Albany area) NY 12123
www.copelandcoating.com



(518) 766-2932
(800) 303-4219
Fax: (518) 766-3603
E-mail: ActionPave@copelandcoating.com

"The pavement maintenance people...since 1945"

have accumulated due to the holding of water. Spread the mixed emulsion over the low spot using a squeegee, if size permits, floating the material into the low spot in 1/4" to 1/2" lifts. Allow material to dry thoroughly. Scrape and repeat process until desired level is achieved. Smooth surface and prepare it for ACTION PAVE ACRYLIC FILLER and FINISH coats.

The filling of cracks requires surface cracks to be thoroughly clean and dry. Squeegee with a horseshoe squeegee, filling to refusal. Multiple applications may be required. For structural cracks rout, air blow and thoroughly clean and dry. Fill to refusal using a horseshoe squeegee. Multiple applications will be required. After final application, scrape areas of repair thoroughly and make final repairs before applying ACTION PAVE ACRYLIC RESURFACER, FILLER or FINISH.

LIMITATIONS -

- Do not apply ACTION PAVE ACRYLIC CRACK AND LEVELING BINDER PATCH when surface temperature is below 50°F (10°C) or when fog, rain or high humidity is imminent.
- Do not apply if surface temperature is above 130°F (55°C).
- Do not store in direct sunlight.
- Close covers tightly.
- Keep from freezing.



**COPELAND COATING
COMPANY, INC.**



ACTION-PAVE®
ATHLETIC SURFACES

ACTION PAVE ACRYLIC FILLER COAT(S)

DESCRIPTION -

100% acrylic emulsion, special reinforcing pigments and pure silica sand that provides a uniform and controlled texture which is extremely durable, however, remains flexible. ACTION PAVE ACRYLIC FILLER COAT(S) has been specifically engineered to protect asphalt and concrete surfaces from the harsh northeast weather conditions. Unlike other acrylic surfacing fillers, ACTION PAVE ACRYLIC FILLER is fully pigmented, resulting in longer lasting, richer, full depth color.

USE -

Apply over existing color coated surfaces to rejuvenate and add texture. The ACTION-PAVE ACRYLIC FILLER coat(s) can be tailored to increase or decrease the speed of the surface. Apply over new surfaces which have had the ACTION PAVE ACRYLIC RESURFACER properly applied and cured.

APPLICATION -

Use a standard, commercial quality, squeegee 24", 30" or 36" in width. Clean squeegee with water immediately after use.

MIX DESIGN -

ACTION PAVE ACRYLIC FILLER is concentrated and needs to be mixed on site with clean water. Thorough mixing is required. Mortar mixer offers best results.

2 parts ACTION PAVE ACRYLIC FILLER
1 part water

COVERAGE -

To surface the standard tennis court (800 square yards) a one (1) coat application will require 60 gallons of concentrated ACTION PAVE ACRYLIC FILLER. A two (2) coat application will require 115 gallons of concentrated ACTION PAVE ACRYLIC FILLER. A three (3) coat application will require 165 gallons of concentrated ACTION PAVE ACRYLIC FILLER. Approximate coverage ratio for a standard two (2) coat application = 7 square yards per gallon of concentrate.

SURFACE PREPARATION AND APPLICATION -

The surface must be clean and free of grease, oil and any other foreign material. ACTION PAVE ACRYLIC FILLER coat is to be applied over previously color coated surfaces or new surfaces which have already had ACTION PAVE ACRYLIC RESURFACER applied. All crack repair and other preparation must be completed.

Spread ACTION PAVE ACRYLIC FILLER coat evenly by walking in one direction and then reversing direction. Always maintain a wet edge and do not overwork the material. Avoid leaving any puddles when squeegeeing material back and forth. Before applying the next filler coat, or the final finish coat, allow coating to dry sufficiently and inspect it. Scrape off any ridges, lumps or other imperfections and then apply the next coat.

Page 1 of 2

3600 US Route 20
PO Box 595
Nassau, (Albany area) NY 12123
www.copelandcoating.com



(518) 766-2932
(800) 303-4219
Fax: (518) 766-3603
E-mail: ActionPave@copelandcoating.com

"The pavement maintenance people...since 1945"

LIMITATIONS -

- Do not apply ACTION PAVE ACRYLIC FILLER coat(s) when surface temperature is below 50°F (10°C) or when fog, rain or high humidity is imminent.
- Do not apply if surface temperature is above 130°F (55°C).
- Do not store in direct sunlight.
- Close cover tightly.
- Keep from freezing.

	Medium Green	Dark Green	Red	Blue	Gray	Beige (Sand)	White Line Paint
Non Volatile	30.4%	31.2%	30.5%	30.7%	31.7%	31.5%	47.0%
Volatile	69.6%	68.8%	69.5%	69.3%	68.3%	68.5%	
<i>Non Volatile:</i>							
Chromium Oxide	12.3%	11.9%					
Iron Oxide		2.6%	14.8%	3.0%	2.9%	10.0%	
Silica & Silicates	45.7%	44.5%	44.6%	44.1%	43.2%	44.7%	16.6%
Titanium Dioxide				10.8%	14.6%	6.6%	57.9%
Phthalocyanine Blue				2.1%			
Additives	9.9%	9.7%	9.3%	9.1%	9.0%	8.0%	5.6%
Acrylic Polymer	32.1%	31.3%	31.3%	30.9%	30.3%	30.7%	19.9%
<i>Volatile:</i>							
Alcohols & Glycols	4.9%	4.9%	4.9%	4.9%	4.9%	4.9%	4.9%
Water	95.1%	95.1%	95.1%	95.1%	95.1%	95.1%	94.1%

Dilution Ratio: 55 gallons ACTION PAVE concentrate 0 to 500 pounds sand (dependent upon surface and playing speed desired) 24 to 30 gallons water

Viscosity: Brookfield #6 spindle - 20 RPM 1 1,500 cps. * 2,000 cps. (avg.)

pH: 9.0 * .6 (avg.)



**COPELAND COATING
COMPANY, INC.**



ACTION-PAVE®
ATHLETIC SURFACES

ACTION PAVE® ACRYLIC RESURFACER

DESCRIPTION -

ACTION PAVE ACRYLIC RESURFACER (concentrated acrylic resurfacing emulsion) is a heavy bodied, 100% acrylic emulsion developed specifically for use on open or pitted asphalt surfaces to reduce porosity and provide a uniform surface texture. Application of ACTION PAVE ACRYLIC RESURFACER provides an economical means for filling voids in asphalt pavements and protecting the asphalt from ultra-violet rays.

USE -

Apply over newly paved surfaces or old, severely oxidized, pitted surfaces.

APPLICATION -

Use a standard, commercial quality, squeegee 24", 30" or 36" in width, or spray apply product. Clean squeegee or sprayer with water immediately after use.

MIX DESIGN -

ACTION PAVE ACRYLIC RESURFACER is concentrated and needs to be mixed on site with clean water. Thorough mixing is required. Mortar mixer offers best results.

2 parts ACTION PAVE ACRYLIC RESURFACER
1 part water

COVERAGE -

The amount of material needed will vary slightly due to variation in density of the asphalt substrate and the technique of application. Approximate coverage ratio = twelve (12) square yards per gallon of concentrate.

SURFACE PREPARATION AND APPLICATION -

The surface must be clean and free of grease, oil and any other foreign material. New asphalt shall cure a minimum of five (5) days and may require a longer curing period in cold or dry climate areas. Pour a ribbon of material along one end of the area to be surfaced. Spread evenly by walking in one direction and then reversing direction or spray product in same manner. Always maintain a wet edge and do not overwork material. Before applying the next coat of material, inspect coating and scrape off any ridges, lumps or other imperfections and then apply the next coat 90° to this coat.

LIMITATIONS -

- Do not apply ACTION PAVE ACRYLIC RESURFACER when surface temperature is below 50°F (10°C) or when fog, rain or high humidity is imminent.
- Do not apply if surface temperature is above 130°F (55°C).
- Do not store in direct sunlight.
- Close cover tightly.
- Keep from freezing.

3600 US Route 20
PO Box 595
Nassau, (Albany area) NY 12123
www.copelandcoating.com



(518) 766-2932
(800) 303-4219
Fax: (518) 766-3603
E-mail: ActionPave@copelandcoating.com

"The pavement maintenance people...since 1945"



**COPELAND COATING
COMPANY, INC.**



ACTION-PAVE®
ATHLETIC SURFACES

ACTION PAVE ACRYLIC WHITE LINE PAINT

DESCRIPTION -

ACTION PAVE ACRYLIC WHITE LINE PAINT is an extremely durable 100% acrylic emulsion carefully formulated for use on tennis and basketball courts, running tracks and any other indoor or outdoor recreational surface. It offers a neat, clean, permanent line of marking. It is designed to be applied over all other ACTION PAVE products.

USE -

Line and event markings for tennis and basketball courts, running tracks and any other indoor or outdoor recreational surface.

APPLICATION -

Apply with a paint brush, roller or other suitable paint application equipment. Clean equipment with water immediately after use.

MIX DESIGN -

ACTION PAVE ACRYLIC WHITE LINE PAINT is to be used as is. DO NOT ADD WATER.

COVERAGE -

One gallon will be adequate to do one doubles tennis court.

SURFACE PREPARATION AND APPLICATION -

The surface must be clean and free of grease, oil and any other foreign material. Apply as you would any other paint.

LIMITATIONS -

- Do not apply ACTION-PAVE WHITE LINE PAINT when surface temperature is below 50°F (10°C) or when fog, rain or high humidity is imminent.
- Do not apply if surface temperature is above 130°F (55°C).
- Do not store in direct sunlight.
- Close cover tightly.
- Keep from freezing.

IMPORTANT NOTE -

Allow lines to dry and cure for 24 hours before allowing any play on the new surface.

Page 1 of 1

3600 US Route 20
PO Box 595
Nassau, (Albany area) NY 12123
www.copelandcoating.com



(518) 766-2932
(800) 303-4219
Fax: (518) 766-3603
E-mail: ActionPave@copelandcoating.com

"The pavement maintenance people...since 1945"

OMNISPORTS 6.5 mm

Omnisports 6.5 mm is a vinyl multi-use sports floor containing a non-woven fiberglass layer and PVC foam backing. Its slightly textured surface is protected with Top Clean xp®, allowing easy maintenance.

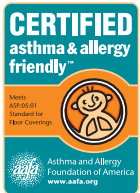
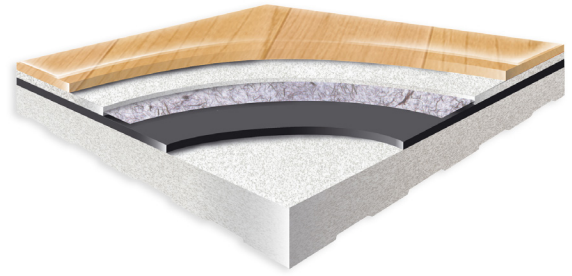

Warranty Protection

- 10 year product coverage and 15 year wear layer coverage. Refer to sample warranty document for complete coverage details.

Environmental Facts and LEED

- For environmental facts and LEED credits, visit: tarkettsportsindoor.com/en/specs-and-data/environmental-fact-sheets and tarkettsportsindoor.com/en/specs-and-data/leed-information.

Maintenance Instructions

- For a complete maintenance guide, visit: tarkettsportsindoor.com/en/specs-and-data/care-and-maintenance.

Installation Methods

- GreenLay™: perimeter glue installation requiring only 2% of the surface area to be glued with Tarkett's solvent-free Multi-Poxy adhesive (moisture tolerance: 92% RH per ASTM F2170)
- Full Adhesive: full glue installation using Tarkett's solvent-free Multi-Poxy adhesive over the entire surface area (moisture tolerance: 92% RH per ASTM F2170)
- Tarkolay: installation over Tarkolay moisture barrier (moisture tolerance: 98% RH per ASTM F2170)

Sports Characteristics

Property	Standard	Value
Surface Finish Effect	ASTM F2772-11	Passed
Force Reduction	ASTM F2772-11	Class 2
Vertical Deformation	ASTM F2772-11	Passed
Ball Rebound	ASTM F2772-11	Passed

Technical Characteristics

Property	Standard	Value
Reaction to Fire	ASTM E648	Class 1 (Radiant Panel)
Below-Room Sound Insulation	ISO 717/02	+/- 19 dB
In-Room Sound Insulation	NF S31-074	61 dB
Static Load Tolerance	ASTM F970 (modified)	200 psi
Indentation Resistance	EN 1516	0.21 mm — 0.40 mm
Rolling Load	EN 1569	≤ 0.5 mm (No Degradation)
Resistance to Impact	EN 1517	No Degradation
Taber Abrasion	ASTM D3389	0.02 g (1,000 Cycles)
Stain Resistance	ASTM F925	Excellent
Roll Width	EN 426/EN 427	2 m (6.5')
Roll Length	EN 426/EN 427	26 m (85.3')
Thickness	EN 428/EN 429	6.5 mm (0.256")
Weight	EN 430	4.7 kg/m ² (0.96 lbs./sq. ft.)
Wear Layer	EN 429	0.70 mm
Microbial Resistance	ASTM G21 (backing)	No growth

Compatible substrates include: properly constructed and prepared concrete, wood, asphalt, and cementitious underlayments. Refer to current installation guidelines, ASTM F710, ACI 302.2R, and other industry standard recommendations for more information. Tarkett Sports reserves the right to modify these specifications without affecting their compliance with standards. Some results may vary in relation to certain flexibilities found within specified testing procedures and manufacturing tolerances.

888.364.6541
tarkettsportsindoor.com



Available Colors for Omnisports 6.5 mm



Light Maple



Beech[◇]

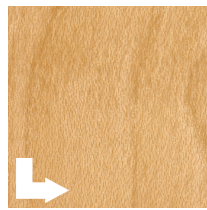

Golden Maple

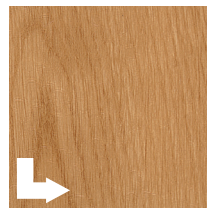

Classic Oak[◇]



Gunstock Oak[◇]



Dark Beech[◇]

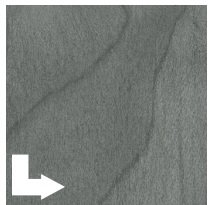

Grey Maple



Mint Green Maple

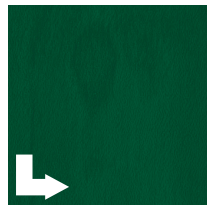

Green Maple



Sky Blue Maple

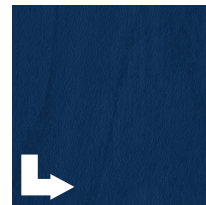

Blue Maple

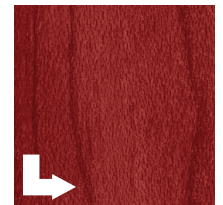

Red Maple



Yellow



Orange



Dark Orange



Purple



Magenta



Red

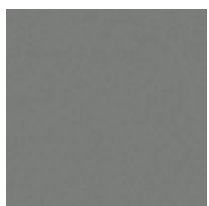

Grey



Black

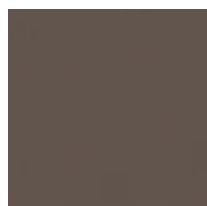

Brown



Sky Blue



Night Blue



Royal Blue



Forest Green



Mint Green



Light Green

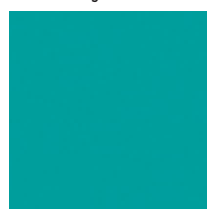

Teal

The colors presented here are representations only. An actual sample is recommended for exact color evaluation and matching.
[◇]This pattern has a 3" wide plank. Maple patterns have a width of 2 3/4".

 Quick Ship

POLYTURF PLUS

7+2 Pad and Pour

PolyTurf Plus Pad and Pour 7+2 is a seamless polyurethane sports surface that is designed for durability. This field-constructed system includes a 7 mm recycled rubber base mat for comfort and shock absorption.

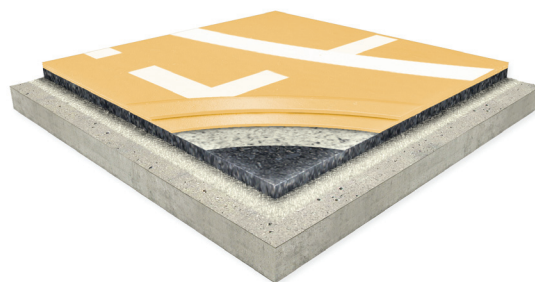

Warranty Protection

- 8-year comprehensive product coverage. Refer to sample warranty document for complete coverage details.

Environmental Facts and LEED

- For environmental facts and LEED credits, visit: tarkettsportsindoor.com/en/specs-and-data/environmental-fact-sheets and tarkettsportsindoor.com/en/specs-and-data/leed-information.

Maintenance Instructions

- For maintenance instructions, please refer to the PolyTurf Plus Pad and Pour maintenance guide at the following link: tarkettsportsindoor.com/en/specs-and-data/care-and-maintenance.

Installation Methods

- Multi-Poxy Adhesive:** installation using Tarkett's solvent-free Multi-Poxy adhesive, which allows moisture tolerance of up to 92% relative humidity per ASTM F2170.
- Beybond 50 Adhesive:** installation using Beybond 50 two-part polyurethane adhesive, which allows moisture tolerance of up to 83% relative humidity per ASTM F2170.
- Tarkolay with Multi-Poxy:** installation over Tarkolay moisture barrier using Tarkett's solvent-free Multi-Poxy adhesive, which allows moisture tolerance of up to 98% relative humidity per ASTM F2170.

Sports Characteristics

Property	Standard	Value
Surface Finish Effect	ASTM F2772-11	Passed
Force Reduction	ASTM F2772-11	Class 2
Vertical Deformation	ASTM F2772-11	Passed
Ball Rebound	ASTM F2772-11	Passed

Technical Characteristics

Property	Standard	Value
Reaction to Fire	ASTM E648	Class 1 (Radiant Panel)
Shore Hardness	—	80 (Shore A)
Tensile Strength	ASTM D412	1600 psi
Elongation	ASTM D412	150%
Tear Strength	ASTM D624	122 PLI
Thickness	—	9.0 mm (0.354")
Roll Width (Base Mat)	—	1.5 m (59")
Roll Length (Base Mat)	—	25 m (82')
Weight (Base Mat)	—	4.5 kg/m ² (0.93 lbs./sq. ft.)
Density (Base Mat)	ASTM D297	0.67 min g/cm ³
Tensile Strength (Base Mat)	ASTM D412	88 psi (die cast C)
Elongation (Base Mat)	ASTM D412	48.5% (die cast C)
Compression (Base Mat)	ASTM F36	87% (50 psi), 91% (100 psi), 91% (200 psi)
Flexibility (Base Mat)	ASTM F147	0-1
Compression Set B (Base Mat)	ASTM D395	37% (25% deflection, 158° F/22 hrs.)
Compression Set B (Base Mat)	ASTM D395	37% (25% deflection, 158° F/22 hrs.)

Compatible substrates include: properly constructed and prepared concrete, wood, asphalt, and cementitious underlayments. Refer to current installation guidelines, ASTM F710, ACI 302.2R, and other industry standard recommendations for more information. Tarkett Sports reserves the right to modify these specifications without affecting their compliance with standards. Some results may vary in relation to certain flexibilities found within specified testing procedures and manufacturing tolerances.

888.364.6541
tarkettsportsindoor.com



Available Colors for PolyTurf Plus Pad and Pour 7+2

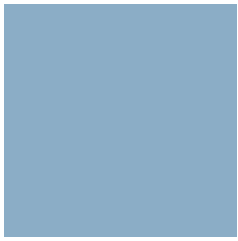

Sky Blue



Pool Blue



Blue Jay



Deep Blue



Coastal Blue



Teal Blue



Midnight Blue



Aqua



Red



Red Rub

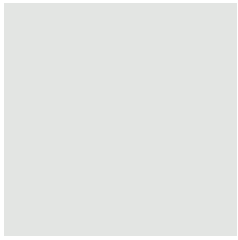

Grey Cloud



Grey Smoke



Storm Grey



Black



Orange

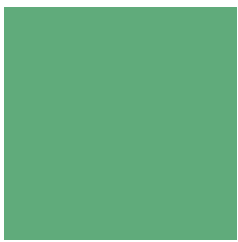

Tropical Green



Garden Green

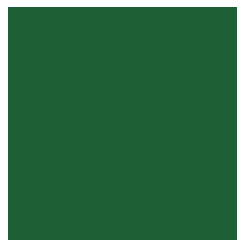

Forest Green



Violet

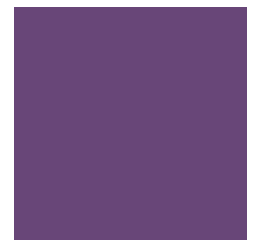

Purple



Sand



Tan



Smoothie



Desert



Gold

The colors presented here are representations only.

For information on obtaining individual color swatches, contact a local Tarkett Sports representative or call 888-364-6541.

TARKOLAY Moisture Barrier

Tarkolay is a resilient slip sheet membrane designed to act as a moisture barrier for flooring installations. It does so by separating the vapor pressure of the concrete from the flooring above.

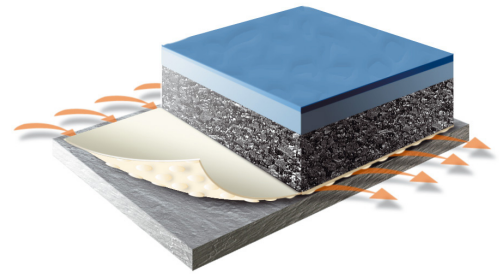

Installation Options

- PolyTurf Plus Pad and Pour Flooring: Tarkolay can be installed as an underlayment for PolyTurf Plus Pad and Pour systems using Tarkett Sports' Multi-Poxy adhesive.
- Omnisports Multi-Use Sports Flooring: Tarkolay can be installed as an underlayment for Omnisports flooring using Tarkett Sports' Multi-Poxy adhesive.
- Dropzone and Dropzone Speckle Weight Room Flooring: Tarkolay can be installed as an underlayment for Dropzone and Dropzone Speckle flooring using Tarkett Sports' Multi-Poxy adhesive.

Installation Method

- Tarkolay is installed in a direction parallel to the sheet flooring surface and offset.

Heating System Compatibility

- Tarkolay is compatible with in-slab heating systems (conditions required).

Performance Characteristics

Property	Standard	Value
Moisture Tolerance	ASTM F2170	96% RH

Technical Characteristics

Property	Standard	Value
Material Type	—	Resilient Sheet Vinyl
Color	—	White
Surface Texture	—	Smooth
Backing Texture	—	Dimpled
Roll Width	EN 426/EN 427	2 m (6.5')
Roll Length	EN 426/EN 427	45 m (147' 7")
Thickness	EN 428/EN 429	1.3 mm (0.05")
Weight	EN 430	1.16 kg/m ² (0.26 lbs./sq. ft.)
Permeance	ASTM E96	< 0.20 Perm
Dimensional Stability	EN 434	0.01%

Compatible substrates include: properly constructed and prepared concrete, wood, asphalt, and cementitious underlayments. Refer to current installation guidelines, ASTM F710, ACI 302.2R, and other industry standard recommendations for more information. Tarkett Sports reserves the right to modify these specifications without affecting their compliance with standards. Some results may vary in relation to certain flexibilities found within specified testing procedures and manufacturing tolerances.

888.364.6541
tarkettsportsindoor.com

Tarkett Sports

EIGHT-YEAR LIMITED MANUFACTURER'S WARRANTY

WARRANTOR: FieldTurf USA, Inc.
175 N Industrial Blvd N.E.
Calhoun, Georgia
30701

OWNER: (“Insert Owner’s Name and Address”)

PRODUCT: PolyTurf Plus Pad & Pour

WARRANTY: FieldTurf warrants to Owner, subject to the terms and conditions contained in this Warranty, that the above-described Surface is free from defects in materials and workmanship under normal use and service, so long as the Surface was installed in accordance with the drawings, plans and specifications for the Surface.

WARRANTY PERIOD: This Warranty shall be in force for a period of 96 months from the Effective Date as defined below.

RESPONSE FOR WARRANTY REPAIRS: FieldTurf agrees to perform all repairs required by this Warranty within a reasonable time upon receiving proper written notice from Owner as provided below and after FieldTurf carries out all inspections and tests, which it may deem necessary or advisable. Any required repair work shall be initiated by FieldTurf within a reasonable time from FieldTurf’s receipt of Owner’s written notice requesting such repairs.

LIMITATIONS AND EXCLUSIONS: This Warranty does not apply to any defect, failure, damage, or undue wear in or to the Surface caused by or connected with: (a) the installation process of the Surface on the Owner’s base; (b) improper or insufficient design or engineering, or improper or insufficient project drawings, plans or specifications; (c) an inadequate or defective pre-existing base or surface; (d) the inherent characteristics of the earth or surface upon which the Surface is installed; (e) misuse, abuse, or deliberate acts of vandalism; (f) accident, negligence, or acts of God; (g) static or dynamic loads exceeding FieldTurf’s recommendations; (h) use of improper cleaning methods; or (i) Owner’s failure to care for and maintain the Surface in accordance with FieldTurf’s written instructions. FieldTurf does not warrant or guarantee the accuracy or sufficiency of any drawings, plans, or specifications not prepared by FieldTurf and which are used in connection with installing the Surface. This Warranty shall be of no force and effect if FieldTurf is not paid in full for the Surface and FieldTurf’s obligations under this Warranty are expressly contingent upon FieldTurf being paid in full for the Surface.

This Warranty shall not apply to the Surface, or any part thereof, which has been repaired or altered without FieldTurf’s prior written consent. No allowance or credit will be granted for any repairs or alterations to the Surface made by Owner except as authorized by this Warranty.

THIS WARRANTY IS EXPRESSLY IN LIEU OF ALL OTHER WARRANTIES, EXPRESSED, IMPLIED OR ARISING BY OPERATION OF LAW, INCLUDING (BUT NOT LIMITED TO) ANY IMPLIED WARRANTIES OF MERCHANTABILITY OR FITNESS FOR A PARTICULAR PURPOSE AND OF ALL OTHER OBLIGATIONS OR LIABILITIES ON FIELDTURF’S PART. FIELDTURF SHALL NOT BE LIABLE FOR ANY DAMAGES UNDER TORT, CONTRACT OR STRICT LIABILITY AND/ OR INCIDENTAL, CONSEQUENTIAL, SPECIAL OR INDIRECT DAMAGES UNDER THIS WARRANTY.

Tarkett Sports

FIELDTURF'S SOLE OBLIGATION UNDER THIS WARRANTY IS TO REPAIR OR REPLACE AT ITS SOLE DISCRETION ALL OR ANY PORTION OF THE SURFACE WHICH MAY BE DETERMINED TO BE DEFECTIVE. FIELDTURF'S LIABILITY FOR ANY SUCH REPAIR OR REPLACEMENT SHALL IN NO EVENT EXCEED THE AMOUNT OF THE PURCHASE PRICE ATTRIBUTABLE TO THE DEFECTIVE PORTION OF THE SURFACE WHICH IS REPAIRED OR REPLACED.

MAINTENANCE INSTRUCTIONS: FieldTurf has supplied Owner with a copy (attached) of the Maintenance Manual containing written instructions for the care and maintenance of the Surface. Owner acknowledges receipt of said Maintenance Manual and agrees to comply with and carry out the instructions contained in it as a condition of this Warranty. The terms of the Maintenance Manual are incorporated in this Warranty by reference.

CLAIMS: All claims by Owner under this Warranty must be made in writing to the following address within thirty calendar days after Owner learns of any defect giving rise to the claim: FieldTurf USA, Inc., Indoor Division, 175 N Industrial Blvd N.E., Calhoun, Georgia 30269.

INSPECTIONS AND TESTS: FieldTurf shall be allowed to inspect the Surface during reasonable business hours regarding any claim, which Owner makes under this Warranty; to be present at and to analyze the results of all tests conducted by Owner or others; and to conduct such tests as FieldTurf in its discretion may deem advisable. Owner shall promptly furnish FieldTurf with a copy of all written reports of any tests performed by Owner or on Owner's behalf. FieldTurf shall not be responsible for any costs or expenses incurred by Owner or others with respect to such tests, except that FieldTurf shall pay for the costs of all tests and analyses conducted or directed by FieldTurf representatives.

EFFECTIVE DATE: The Effective Date of this Warranty is the ____ day of _____, 2014.

FieldTurf USA, Inc.

By: _____

Signature: _____

Title: _____

Date: _____

Enclosed: Instructions for Care and Maintenance of your Product

Tarkett Sports

MANUFACTURER'S LIMITED WARRANTY

WARRANTOR: FieldTurf, USA Inc.
175 N Industrial Boulevard NE
Calhoun, Georgia 30701
USA

OWNER: ("Insert Owner's Name and Address")

SURFACE: OMNISPORTS
("Surface")

WARRANTY DESCRIPTION AND WARRANTY PERIODS:

LIMITED PRODUCT DEFECT WARRANTY: FieldTurf USA, Inc. ("FieldTurf") warrants to Owner, subject to the terms and conditions contained in this Warranty, that the above-described Surface is free from defects in materials and workmanship under normal use and service, as long as the Surface was installed in accordance with the drawings, plans and specifications for the Surface. The Limited Product Defect Warranty shall be in force for a period of ten (10) years from the Effective Date as defined below.

LIMITED WEAR WARRANTY: FieldTurf warrants to Owner, subject to the terms and conditions contained in this Warranty, that there will be no wear-through of the Surface's wear layer under normal use and service, as long as the Surface was installed in accordance with the drawings, plans and specifications for the Surface. For purposes of the Limited Wear Warranty, "wear-through" refers to the top layer of the Surface and means a complete loss of the wear-layer so that the printed layer (pattern or color) is materially changed or affected. The Limited Wear Warranty only shall be in force for a period of fifteen (15) years from the Effective Date.

RESPONSE FOR WARRANTY REPAIRS: FieldTurf agrees to perform all repairs required by this Warranty within a reasonable time upon receiving proper written notice from Owner as provided below and after FieldTurf carries out all inspections and tests, which it may deem necessary or advisable. Any required repair work shall be initiated by FieldTurf within a reasonable time after FieldTurf's receipt of Owner's written notice requesting such repairs. FieldTurf's sole liability under this Warranty shall be limited to either repair or replacement of the affected area of the Surface, at its sole discretion, and FieldTurf shall have no other obligations or liabilities with respect to defects of the Surface.

LIMITATIONS AND EXCLUSIONS: This Warranty does not apply to any defect, failure, damage, and/or accelerated, undue or excessive wear in or to the Surface caused by or connected with: (a) the installation process of the Surface on the Owner's base; (b) improper or insufficient design or engineering, or improper or insufficient project drawings, plans or specifications; (c) an inadequate or defective pre-existing base or surface; (d) the inherent characteristics of the earth or surface upon which the Surface is installed; (e) misuse, abuse, or deliberate acts of vandalism; (f) accident, negligence, or acts of God; (g) static or dynamic loads exceeding FieldTurf's recommendations; (h) use of improper cleaning methods; (i) the introduction or accumulation of moisture around or under the Surface; (j) Owner's failure to care for and maintain the Surface in accordance with FieldTurf's Maintenance Manual and other written instructions; or (k) use which is not generally accepted as a typical use of the Surface. FieldTurf does not warrant or guarantee the accuracy or sufficiency of any drawings, plans, or specifications not prepared by FieldTurf and which are used in connection with installing the Surface. This Warranty shall be of no force and effect if FieldTurf is not paid in full for the Surface and FieldTurf's obligations under this Warranty are expressly contingent upon FieldTurf being paid in full for the Surface.

For more information please contact the Indoor division of FieldTurf at (888) 364-6541.

Tarkett Sports

This Warranty shall not apply to the Surface, or any part thereof, which has been repaired or altered without FieldTurf's prior written consent. No allowance or credit will be granted for any repairs or alterations to the Surface made by Owner except as authorized by this Warranty.

THIS WARRANTY IS EXPRESSLY IN LIEU OF ALL OTHER WARRANTIES, EXPRESSED, IMPLIED OR ARISING BY OPERATION OF LAW, INCLUDING (BUT NOT LIMITED TO) ANY IMPLIED WARRANTIES OF MERCHANTABILITY OR FITNESS FOR A PARTICULAR PURPOSE AND OF ALL OTHER OBLIGATIONS OR LIABILITIES ON FIELDTURF'S PART. FIELDTURF USA, INC. SHALL NOT BE LIABLE FOR ANY DAMAGES UNDER TORT, CONTRACT OR STRICT LIABILITY AND/ OR INCIDENTAL, CONSEQUENTIAL, SPECIAL OR INDIRECT DAMAGES UNDER THIS WARRANTY.

FIELDTURF'S SOLE OBLIGATION UNDER THIS WARRANTY IS TO REPAIR OR REPLACE AT ITS SOLE DISCRETION ALL OR ANY PORTION OF THE SURFACE WHICH MAY BE DETERMINED TO BE DEFECTIVE. FIELDTURF'S LIABILITY FOR ANY SUCH REPAIR OR REPLACEMENT SHALL IN NO EVENT EXCEED THE AMOUNT OF THE PURCHASE PRICE ATTRIBUTABLE TO THE DEFECTIVE PORTION OF THE SURFACE WHICH IS REPAIRED OR REPLACED.

MAINTENANCE INSTRUCTIONS: FieldTurf has made available or supplied Owner with a copy of the Maintenance Manual containing written instructions for the care and maintenance of the Surface. Owner acknowledges receipt of said Maintenance Manual and agrees to comply with and carry out the instructions contained in it as a condition of this Warranty. The terms of the Maintenance Manual are incorporated in this Warranty by reference. If a Maintenance Manual is not received by Owner at the time of issuance of this warranty, it is the owner's obligation to request and maintain record of receipt.

CLAIMS: All claims by Owner under this Warranty must be made in writing to the following address within thirty calendar days after Owner learns of any defect giving rise to the claim: FieldTurf USA, Inc. Indoor Division, 175 N Industrial Blvd. Calhoun, Georgia, 30701.

INSPECTIONS AND TESTS: FieldTurf shall be allowed to inspect the Surface during reasonable business hours regarding any claim, which Owner makes under this Warranty; to be present at and to analyze the results of all tests conducted by Owner or others; and to conduct such tests as FieldTurf in its discretion may deem advisable. Owner shall promptly furnish FieldTurf with a copy of all written reports of any tests performed by Owner or on Owner's behalf. FieldTurf shall not be responsible for any costs or expenses incurred by Owner or others with respect to such tests, except that FieldTurf shall pay for the costs of all tests and analyses conducted or directed by FieldTurf representatives.

GOVERNING LAW AND CONSENT: This Warranty shall be governed by and interpreted in accordance with the law of the State of Georgia.

EFFECTIVE DATE: The Effective Date of this Warranty is the _____ day of _____, 2014.

OWNER'S NAME

FieldTurf USA, Inc.

By: _____

By: _____

Title: _____

Title: _____

Date: _____

Date: _____

For more information please contact the Indoor division of FieldTurf at (888) 364-6541.



SPORTSFIELD SPECIALTIES

41155 STATE HIGHWAY 10
PO BOX 231
DELHI, NY 13753
TOLL FREE: 888-975-3343
FAX: 607-746-8481

"DESIGNED TO MEET THE DEMANDS
OF MODERN SPORTS CONSTRUCTION"



- **6" Square Pole with 4' Extension.**
- **Limited Lifetime Warranty.**
- **Optional Sleeve Sold Separately.**
- **Black Powder Coat Finish.**

402-797 - Spalding Dominator Pole System



SPORTSFIELD SPECIALTIES

41155 STATE HIGHWAY 10
PO BOX 231
DELHI, NY 13753
TOLL FREE: 888-975-3343
FAX: 607-746-8481

"DESIGNED TO MEET THE DEMANDS
OF MODERN SPORTS CONSTRUCTION"



- **High Performance Goal With 180-Degree Action for Collegiate Play**
- **7 Year Warranty.**
- **Meets NCAA and NFHS Specifications**
- **Includes Anti-Whip Net**

411-704 - Slam-Dunk® Precision 180 Goal



SPORTSFIELD SPECIALTIES

41155 STATE HIGHWAY 10
PO BOX 231
DELHI, NY 13753
TOLL FREE: 888-975-3343
FAX: 607-746-8481

"DESIGNED TO MEET THE DEMANDS
OF MODERN SPORTS CONSTRUCTION"



- **Regulation Glass Backboard Meeting FIBA, NCAA, and NFHS Specifications**
- **Direct Goal Mount Designed to Prevent The Goal From Touching The Glass**
- **Limited Lifetime Warranty**

413-003 - SuperGlass Pro Backboard

DESIGNED TO MEET THE DEMANDS
OF MODERN SPORTS CONSTRUCTION



41155 ST. HWY 10
PO BOX 231
DELHI, NY 13753
TOLL FREE: 888-975-3343
FAX: 607-746-8481



- ***Made of a Pliable PVC Plastic that is Guaranteed Not to Crack***
- ***IAAF, NCAA and NFHS Compliant***
- ***Consists of Four (4) Interlocking Sections That Fit Inside a Discus Throw Circle, Instantly Converting to a Hammer Throw Circle***
- ***Easily Installed/Removed and Portable***

PROPRIETARY AND CONFIDENTIAL

THE INFORMATION CONTAINED IN THIS DRAWING IS THE SOLE PROPERTY OF SPORTSFIELD SPECIALTIES INC. ANY REPRODUCTION IN PART OR AS A WHOLE WITHOUT THE WRITTEN PERMISSION OF SPORTSFIELD SPECIALTIES INC. IS PROHIBITED.

TF362 - GILL ATHLETICS HAMMER CONVERSION CIRCLE

NOT TO SCALE

SPORTSFIELD SPECIALTIES INC 09062012

DESIGNED TO MEET THE DEMANDS
OF MODERN SPORTS CONSTRUCTION



41155 ST. HWY 10
PO BOX 231
DELHI, NY 13753
TOLL FREE: 888-975-3343
FAX: 607-746-8481

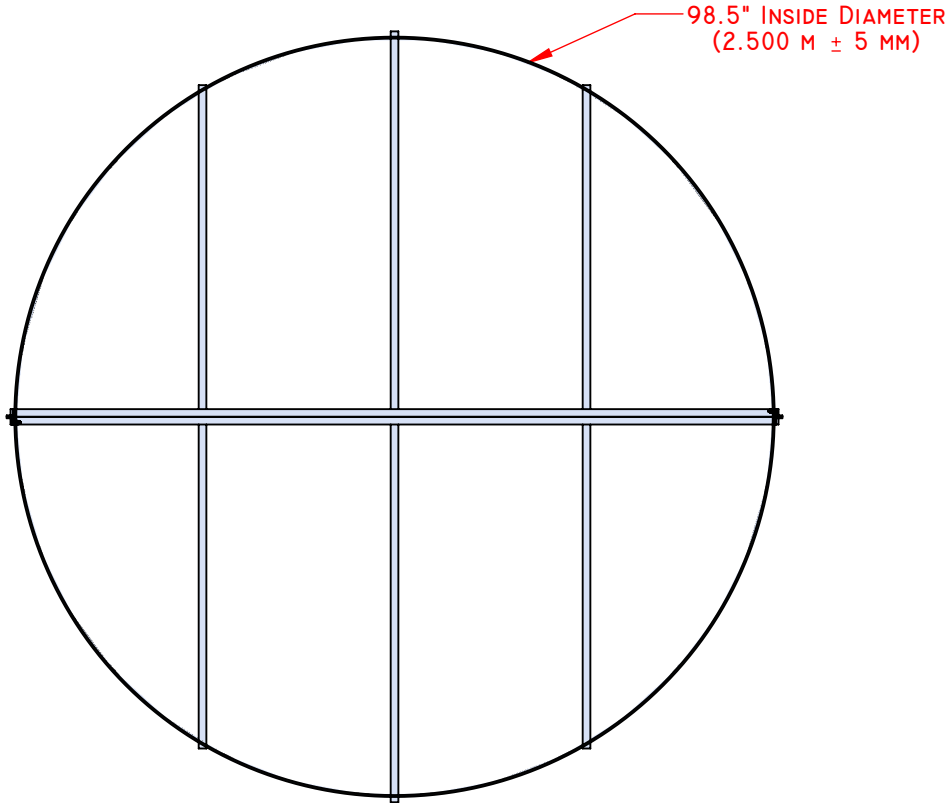

3/4" (0.75") DEPRESSED
FONCRETE FINISHING SCREED LINE

1/4" x 4" ALUMINUM
ROLLED THROW RING

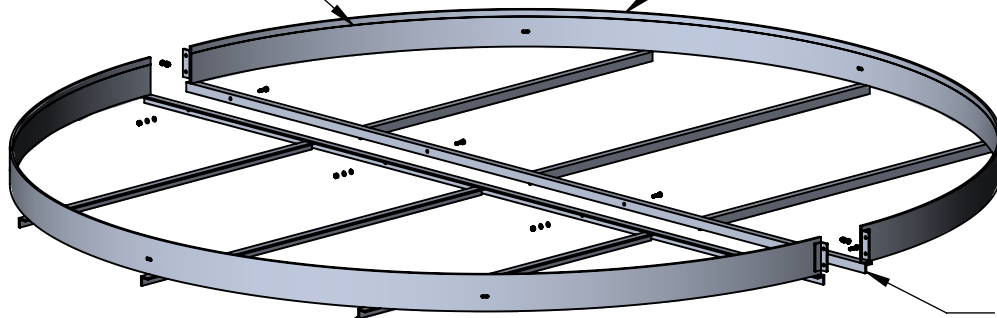

1" x 1" x 3/16" ALUMINUM
ANGLE SUPPORTS

BOLT TOGETHER
CONSTRUCTION
STAINLESS STEEL
HARDWARE INCLUDED

PROPRIETARY AND CONFIDENTIAL

THE INFORMATION CONTAINED IN THIS
DRAWING IS THE SOLE PROPERTY OF
SPORTSFIELD SPECIALTIES INC. ANY
REPRODUCTION IN PART OR AS A WHOLE
WITHOUT THE WRITTEN PERMISSION OF
SPORTSFIELD SPECIALTIES INC. IS
PROHIBITED.

**TFDWRING
DISCUS WEB REINFORCED THROW RING**

NOT TO SCALE

SPORTSFIELD SPECIALTIES INC 12112014

DESIGNED TO MEET THE DEMANDS
OF MODERN SPORTS CONSTRUCTION



41155 ST. HWY 10
PO BOX 231
DELHI, NY 13753
TOLL FREE: 888-975-3343
FAX: 607-746-8481

STANDARD BLACK POWDER COATED FINISH

MEETS AND/OR EXCEEDS CURRENT IAAF
SPECIFICATIONS, RULES AND REQUIREMENTS

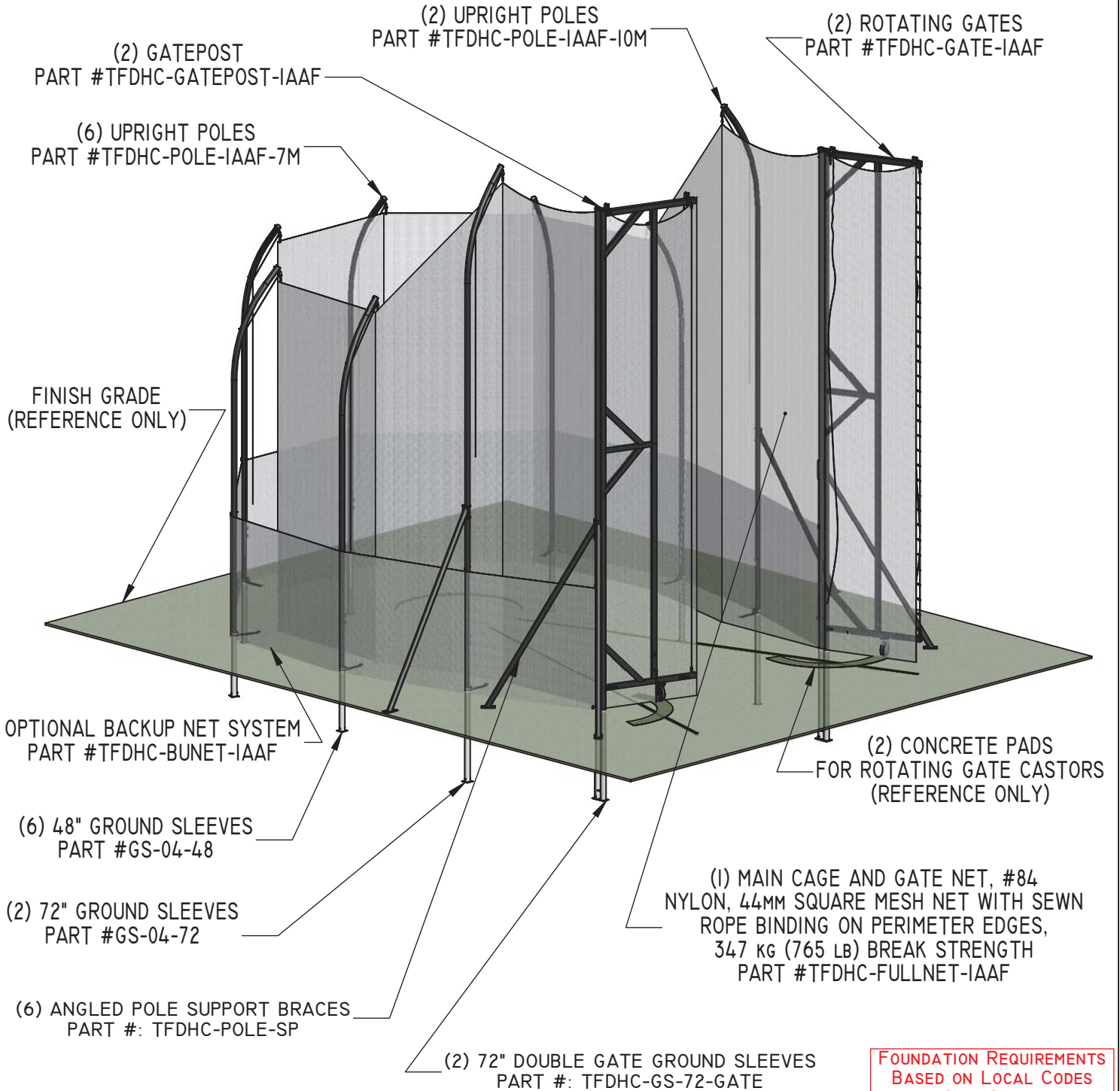

PROPRIETARY AND CONFIDENTIAL
THE INFORMATION CONTAINED IN THIS
DRAWING IS THE SOLE PROPERTY OF
SPORTSFIELD SPECIALTIES INC. ANY
REPRODUCTION IN PART OR AS A WHOLE
WITHOUT THE WRITTEN PERMISSION OF
SPORTSFIELD SPECIALTIES INC. IS
PROHIBITED.

**TFDHCIAAF - IAAF HAMMER/DISCUS CAGE
SINGLE PAD ELEVATION VIEW
WITH OPTIONAL BACKUP NET SYSTEM**

NOT TO SCALE

SPORTSFIELD SPECIALTIES INC 11042014

DESIGNED TO MEET THE DEMANDS
OF MODERN SPORTS CONSTRUCTION



41155 ST. HWY 10
PO BOX 231
DELHI, NY 13753
TOLL FREE: 888-975-3343
FAX: 607-746-8481

WWW.SPORTSFIELDSPECIALTIES.COM

MEETS AND/OR EXCEEDS CURRENT IAAF
SPECIFICATIONS, RULES AND REQUIREMENTS

ROTATING GATE AND SUPPORT POLE
DUAL GROUND SLEEVE (2)

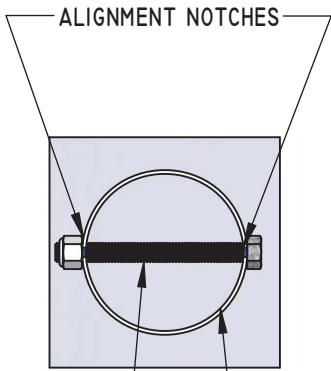
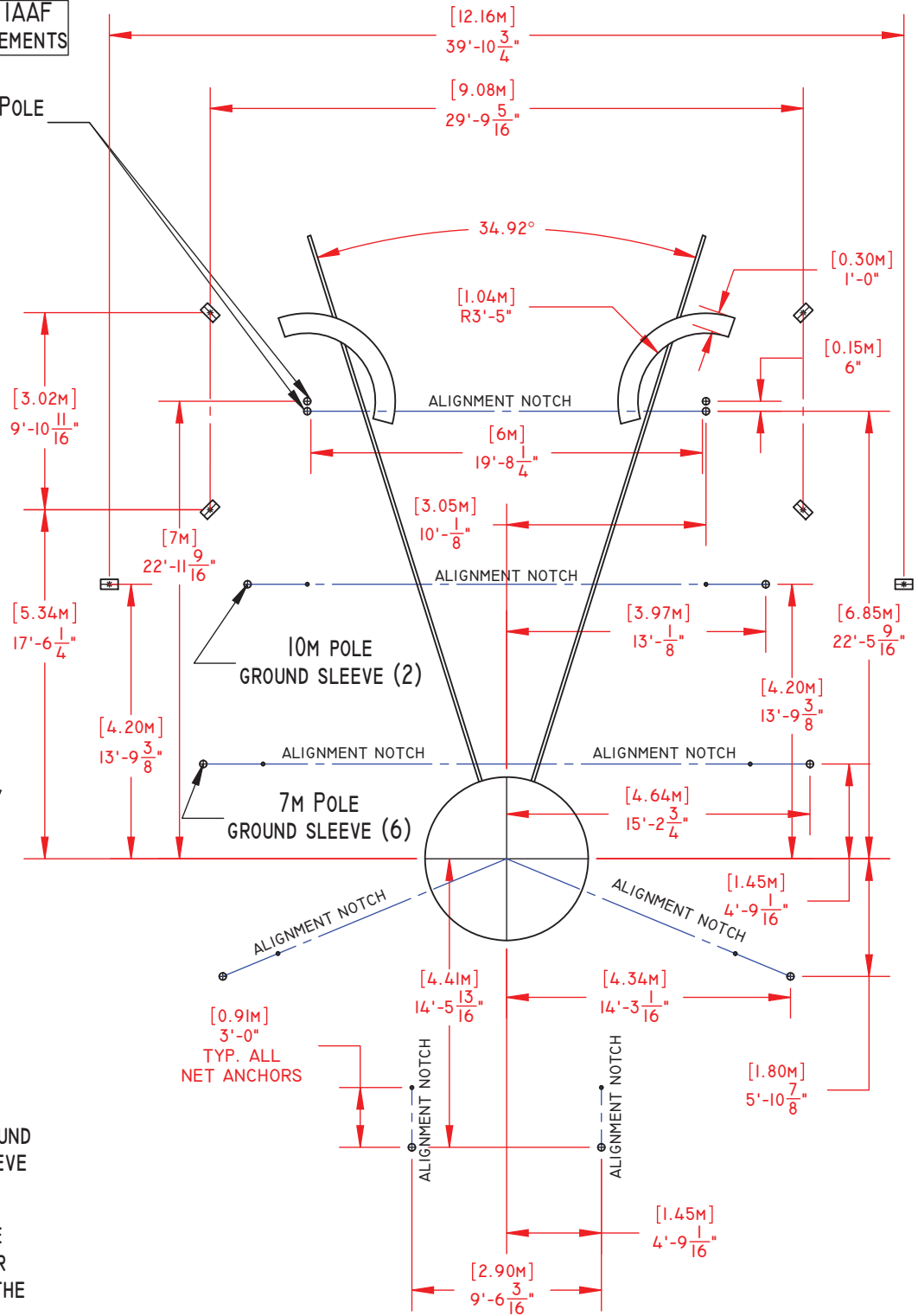

STOP BOLT ——— GROUND SLEEVE

STOP BOLT ALIGNMENTS MUST
MATCH THE ALIGNMENT NOTCH
DIRECTION IN THE LAYOUT IN ORDER
FOR THE CAGE POLES TO LOCK IN THE
CORRECT POSITION.

PROPRIETARY AND CONFIDENTIAL
THE INFORMATION CONTAINED IN THIS
DRAWING IS THE SOLE PROPERTY OF
SPORTSFIELD SPECIALTIES INC. ANY
REPRODUCTION IN PART OR AS A WHOLE
WITHOUT THE WRITTEN PERMISSION OF
SPORTSFIELD SPECIALTIES INC. IS
PROHIBITED.

IAAF HAMMER/DISCUS CAGE, SINGLE PAD GROUND SLEEVE LAYOUT

NOT TO SCALE

SPORTSFIELD SPECIALTIES INC 11202014

DESIGNED TO MEET THE DEMANDS
OF MODERN SPORTS CONSTRUCTION



**SPORTSFIELD
SPECIALTIES**

WWW.SPORTSFIELDSPECIALTIES.COM

41155 ST. HWY 10
PO BOX 231
DELHI, NY 13753
TOLL FREE: 888-975-3343
FAX: 607-746-8481

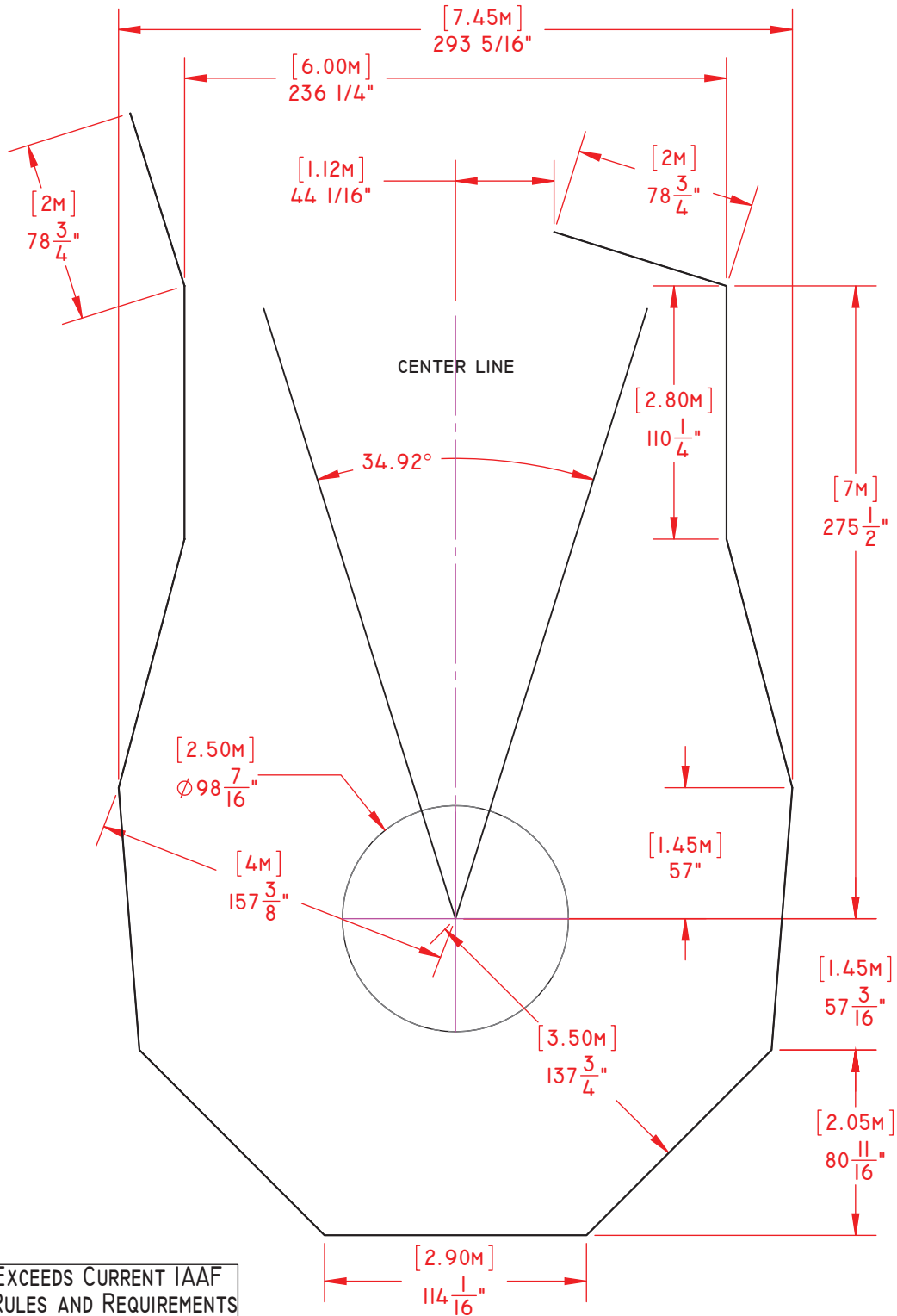

MEETS AND/OR EXCEEDS CURRENT IAAF
SPECIFICATIONS, RULES AND REQUIREMENTS

PROPRIETARY AND CONFIDENTIAL
THE INFORMATION CONTAINED IN THIS
DRAWING IS THE SOLE PROPERTY OF
SPORTSFIELD SPECIALTIES INC. ANY
REPRODUCTION IN PART OR AS A WHOLE
WITHOUT THE WRITTEN PERMISSION OF
SPORTSFIELD SPECIALTIES INC. IS
PROHIBITED.

**TFDHCIAAF - IAAF HAMMER/DISCUS CAGE
SINGLE PAD LAYOUT**

NOT TO SCALE

SPORTSFIELD SPECIALTIES INC 11142014

DESIGNED TO MEET THE DEMANDS
OF MODERN SPORTS CONSTRUCTION



**SPORTSFIELD
SPECIALTIES**

WWW.SPORTSFIELDSPECIALTIES.COM

41155 ST. HWY 10
PO BOX 231
DELHI, NY 13753
TOLL FREE: 888-975-3343
FAX: 607-746-8481

UNITED STATES PATENT #7,641,593, ISSUED JANUARY 5, 2010
UNITED STATES PATENT #8,186,125, ISSUED MAY 29, 2012
UNITED STATES PATENT #8,745,955, ISSUED JUNE 10, 2014

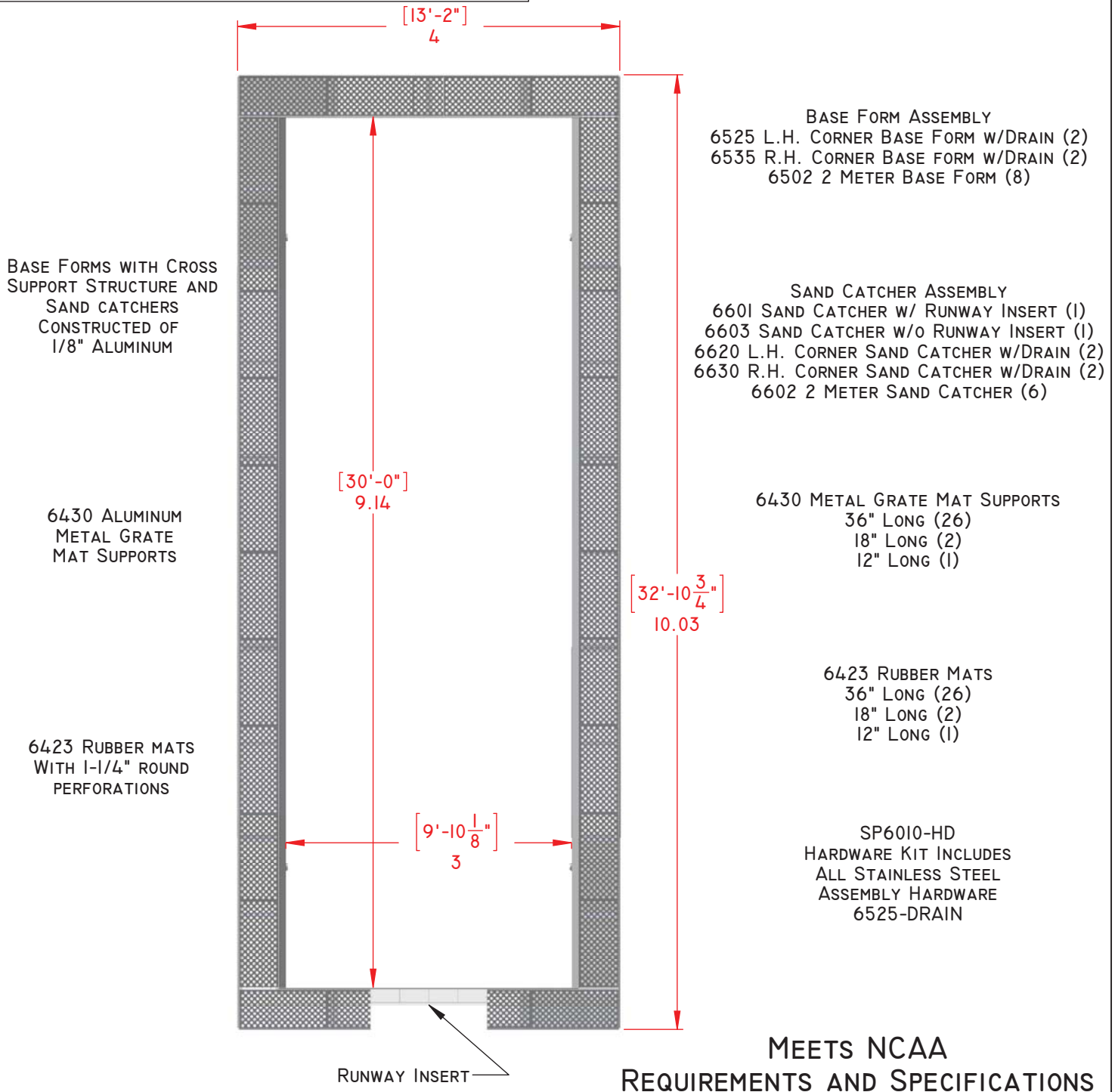

PROPRIETARY AND CONFIDENTIAL
THE INFORMATION CONTAINED IN THIS DRAWING IS THE SOLE PROPERTY OF SPORTSFIELD SPECIALTIES INC. ANY REPRODUCTION IN PART OR AS A WHOLE WITHOUT THE WRITTEN PERMISSION OF SPORTSFIELD SPECIALTIES INC. IS PROHIBITED.

SP6010 JUMPFORM®
COLLEGE 3M x 9M SAND PIT WITH SAND CATCHERS

NOT TO SCALE

SPORTSFIELD SPECIALTIES INC 11012014

DESIGNED TO MEET THE DEMANDS
OF MODERN SPORTS CONSTRUCTION



41155 ST. HWY 10
PO BOX 231
DELHI, NY 13753
TOLL FREE: 888-975-3343
FAX: 607-746-8481

UNITED STATES PATENT #7,641,593, ISSUED JANUARY 5, 2010
UNITED STATES PATENT #8,186,125, ISSUED MAY 29, 2012
UNITED STATES PATENT #8,745,955, ISSUED JUNE 10, 2014

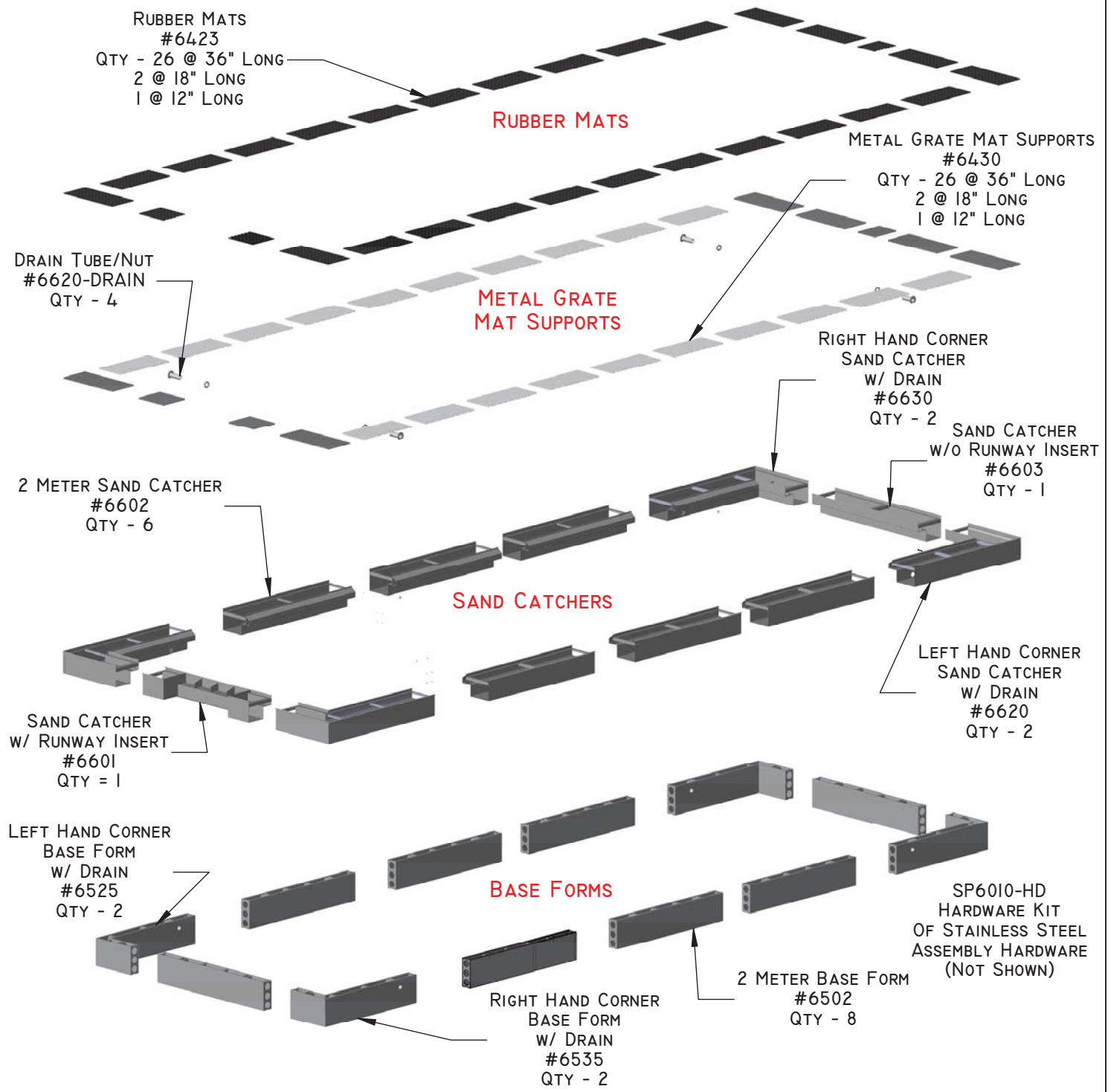

PROPRIETARY AND CONFIDENTIAL
THE INFORMATION CONTAINED IN THIS DRAWING IS THE SOLE PROPERTY OF SPORTSFIELD SPECIALTIES INC. ANY REPRODUCTION IN PART OR AS A WHOLE WITHOUT THE WRITTEN PERMISSION OF SPORTSFIELD SPECIALTIES INC. IS PROHIBITED.

SP6010 JUMPFORM® EXPLODED VIEW
COLLEGE 3M X 9M SAND PIT WITH SAND CATCHERS

NOT TO SCALE

SPORTSFIELD SPECIALTIES INC 11012014

DESIGNED TO MEET THE DEMANDS
OF MODERN SPORTS CONSTRUCTION



41155 ST. HWY 10
PO BOX 231
DELHI, NY 13753
TOLL FREE: 888-975-3343
FAX: 607-746-8481

6800 COLLEGE SAND PIT COVER SET (12-6801 COVERS)

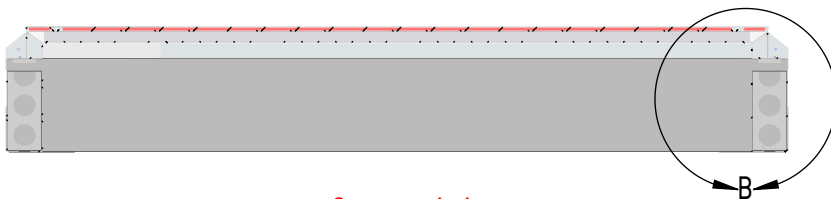
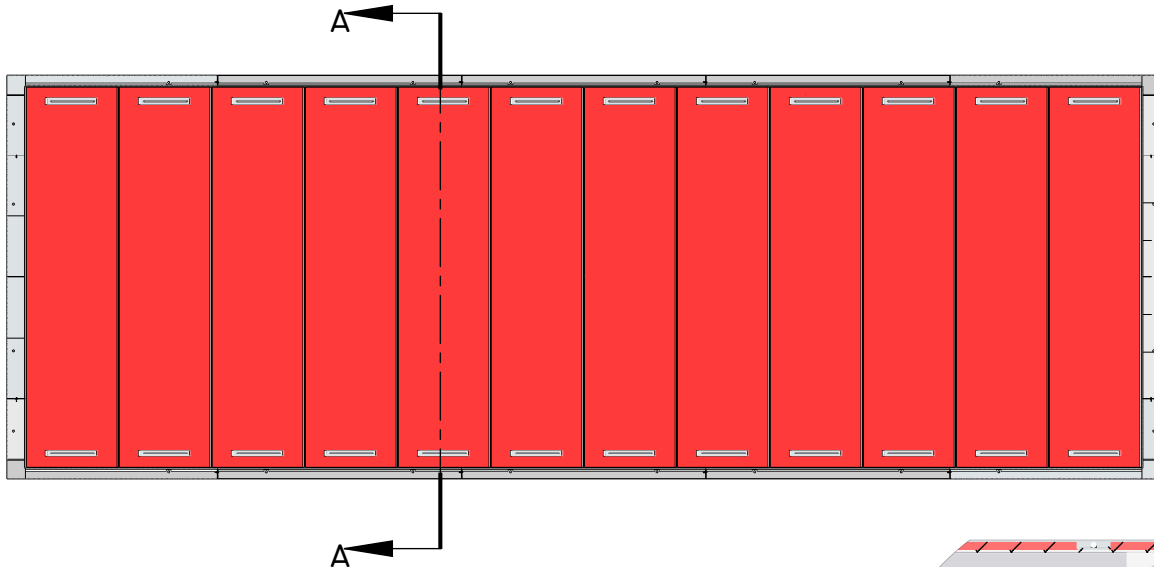

SECTION A-A

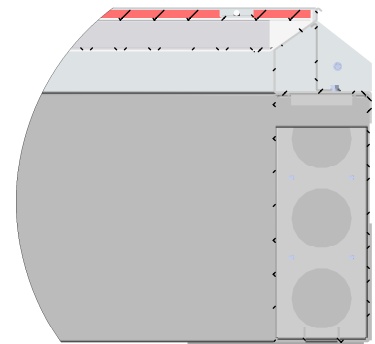

DETAIL B

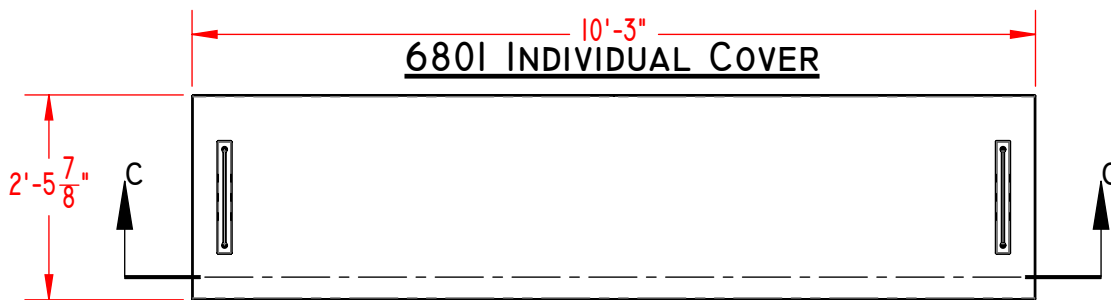

PRODUCT WEIGHTS
6800 - 960LBS/SET
6801 - 80LBS EACH
*WEIGHTS PRIOR
TO SURFACING

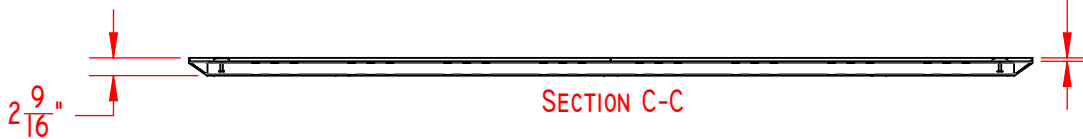

SECTION C-C

$\frac{1}{2}$ " RECESS TO ACCEPT
SYNTHETIC TRACK SURFACE
BY OTHERS

PROPRIETARY AND CONFIDENTIAL

THE INFORMATION CONTAINED IN THIS DRAWING IS THE SOLE PROPERTY OF SPORTSFIELD SPECIALTIES INC. ANY REPRODUCTION IN PART OR AS A WHOLE WITHOUT THE WRITTEN PERMISSION OF SPORTSFIELD SPECIALTIES INC. IS PROHIBITED.

SP6800 COLLEGE SAND PIT COVER SET

NOT TO SCALE

SPORTSFIELD SPECIALTIES INC 11012014

DESIGNED TO MEET THE DEMANDS
OF MODERN SPORTS CONSTRUCTION



41155 ST. HWY 10
PO BOX 231
DELHI, NY 13753
TOLL FREE: 888-975-3343
FAX: 607-746-8481

STANDARD POWDER COATED WHITE FINISH
YELLOW & ORANGE AVAILABLE

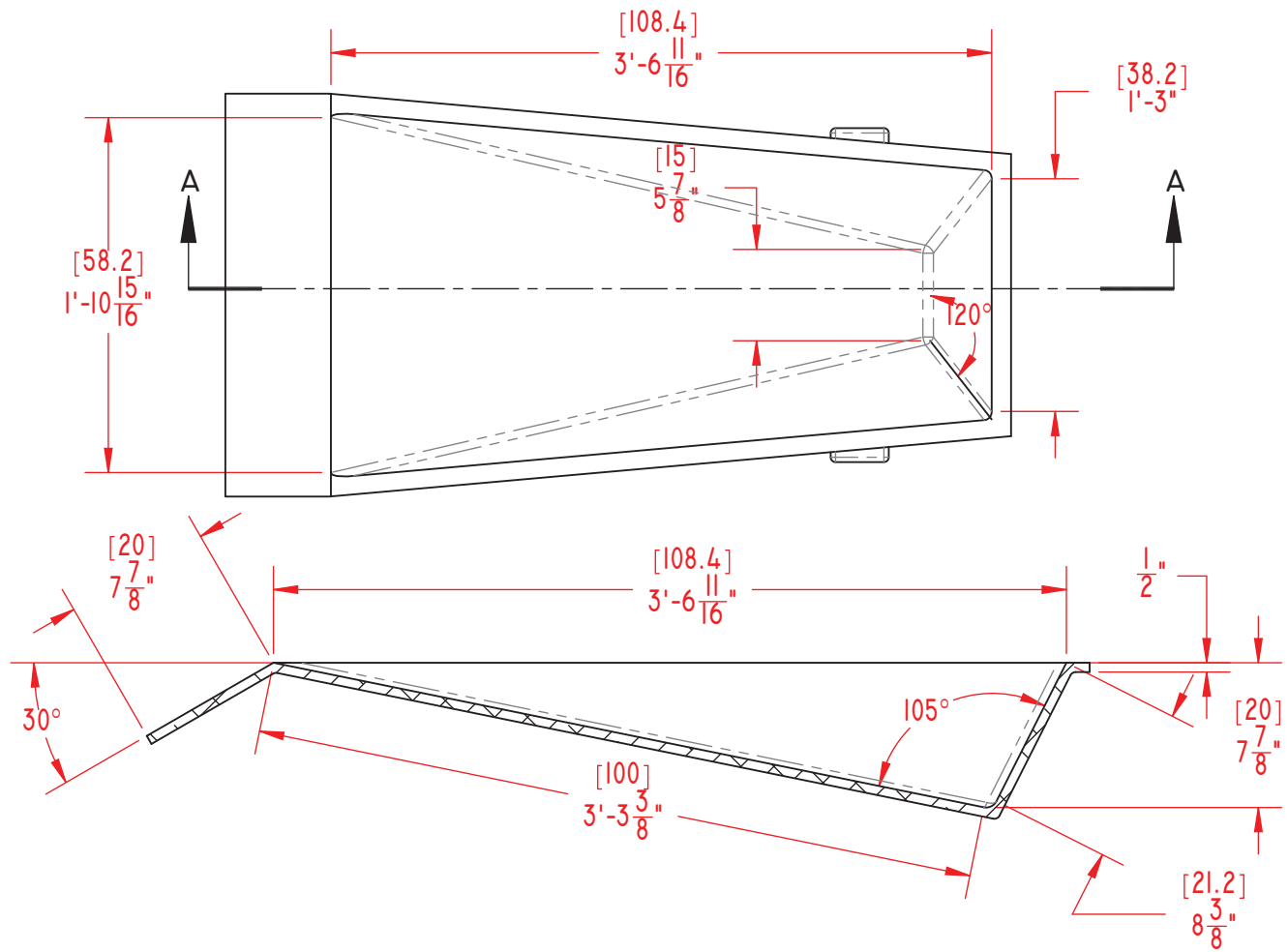
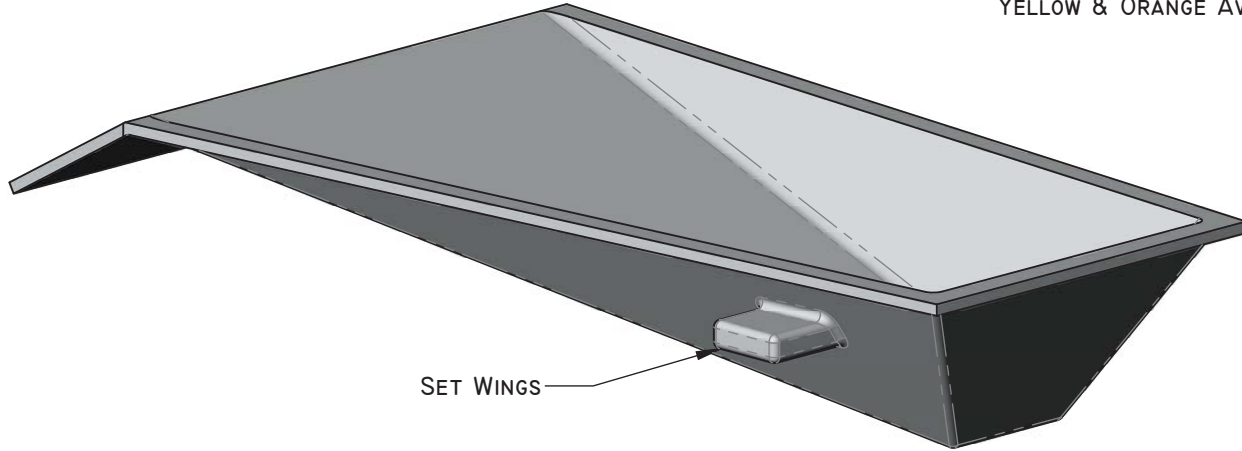

MEETS AND/OR EXCEEDS ALL IAAF, NCAA AND NFHS SPECIFICATIONS

PROPRIETARY AND CONFIDENTIAL

THE INFORMATION CONTAINED IN THIS DRAWING IS THE SOLE PROPERTY OF SPORTSFIELD SPECIALTIES INC. ANY REPRODUCTION IN PART OR AS A WHOLE WITHOUT THE WRITTEN PERMISSION OF SPORTSFIELD SPECIALTIES INC. IS PROHIBITED.

TFPV001CA - CAST ALUMINUM VAULT BOX

NOT TO SCALE

SPORTSFIELD SPECIALTIES INC 11012014

TFPV001CA Cast Aluminum Pole Vault Box with TFPV003ALTR-CA Cover Plug

SECTION 11480 Athletic Equipment - Track & Field

PART 1 GENERAL

1.01 WORK INCLUDED

A. Provide all equipment and materials, and do all work necessary to furnish and install the athletic equipment, as indicated on the drawings and as specified herein. Athletic equipment shall include, but not be limited to:

1. TFPV001CA Vault Box with TFPV003ALTR-CA Cover Plug

1.02 RELATED WORK

A. Examine contract documents for requirements that affect work of this section. Other specification sections that directly relate to the work of this section include, but are not limited to:

1. Section 02200 – Earthwork; Excavation and Backfill and establishment of sub-grade elevations.
2. Section 02511 – Asphalt, Concrete, and Pavement
3. Section 02535 – Synthetic Track Surfacing
4. Section 02542 – Synthetic Field Surfacing
5. Section 03300 – Cast-in-Place Concrete

1.03 REFERENCES

A. Comply with applicable requirements of the following standards. Where these standards conflict with other specified requirements, the most restrictive requirements shall govern.

1. National Federation of State High School Associations (NFHS)
2. National Collegiate Athletic Association (NCAA)
3. International Amateur Athletic Association (IAAF)
4. American Sports Builders Association (ASBA)
5. Manufacturers Data and Recommended Installation Requirements

1.04 SUBMITTALS

A. Manufacturers Product Data

1. Provide manufacturers product data prior to actual field installation work, for Architects or Owners representatives

review.

B. Shop Drawings

1. Provide drawings of the manufacturers recommended installation and foundation requirements prior to actual field installation work, for Architects or Owners representatives review.

1.05 QUALITY ASSURANCE

- A.** Manufacturers warranties shall pass to the Owner and certification made that the product materials meet all applicable grade trademarks or conform to industry standards and inspection requirements.

1.06 PRODUCT DELIVERY AND STORAGE

- A.** Materials delivered to the site shall be examined for damage or defects in shipping. Any defects shall be noted and reported to the Owners representative. Replacements, if necessary, shall be immediately re-ordered, so as to minimize any conflict with the construction schedule. Sound materials shall be stored above ground under protective cover or indoors so as to provide proper protection.

PART 2 PRODUCTS

2.01 Cast Aluminum Pole Vault Box with Cover Plug

BASE: TFPV001CA Pole Vault Box with TFPV003ALTR-CA Cover Plug as manufactured by:

Sportsfield Specialties Inc.
P.O. Box 231
41155 State Highway 10
Delhi, NY 13753
p. 888-975-3343
f. 607-746-8481

B. COMPONENTS:

1. TFPV001CA Pole Vault Box fabricated with ½” Cast Aluminum having the following attributes:
 - A. Regulation Size
 - B. Cast Aluminum Setting Wings for Concrete Encasement
 - C. Powder Coating White (Yellow & Orange Available)

2. TFPV003ALTR-CA Cover Plug fabricated with 1/8" Aluminum having the following attributes:
 - A. Sized to Fill Void of Vault Box
 - B. Top Surface Recessed 1/2" to Accept Synthetic Track Material

PART 3 EXECUTION

3.01 INSTALLATION OF EQUIPMENT

- A. All athletic equipment shall be installed as recommended with manufacturer's written directions, and as indicated on the drawings.

END OF SECTION

DESIGNED TO MEET THE DEMANDS
OF MODERN SPORTS CONSTRUCTION

41155 ST. HWY 10
PO BOX 231
DELHI, NY 13753
TOLL FREE: 888-975-3343
FAX: 607-746-8481

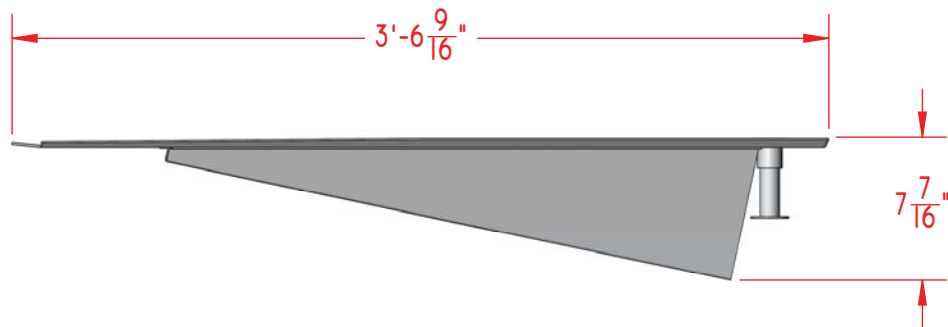
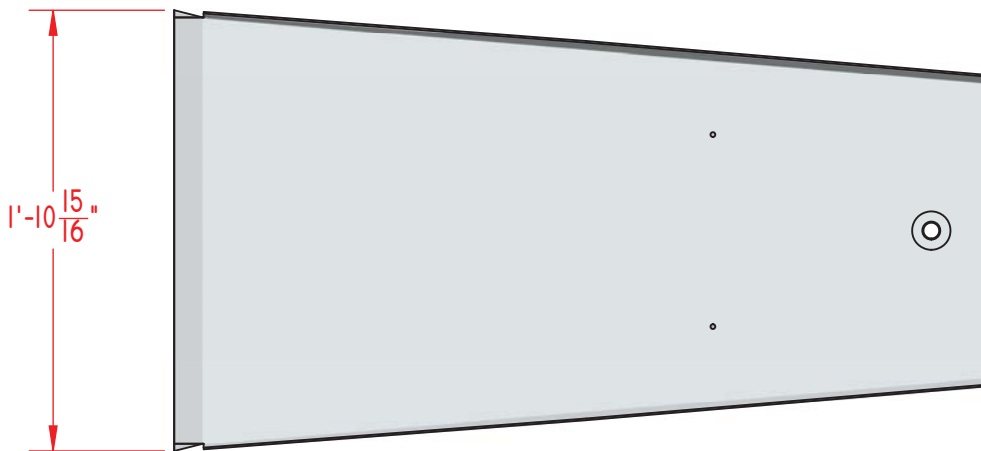
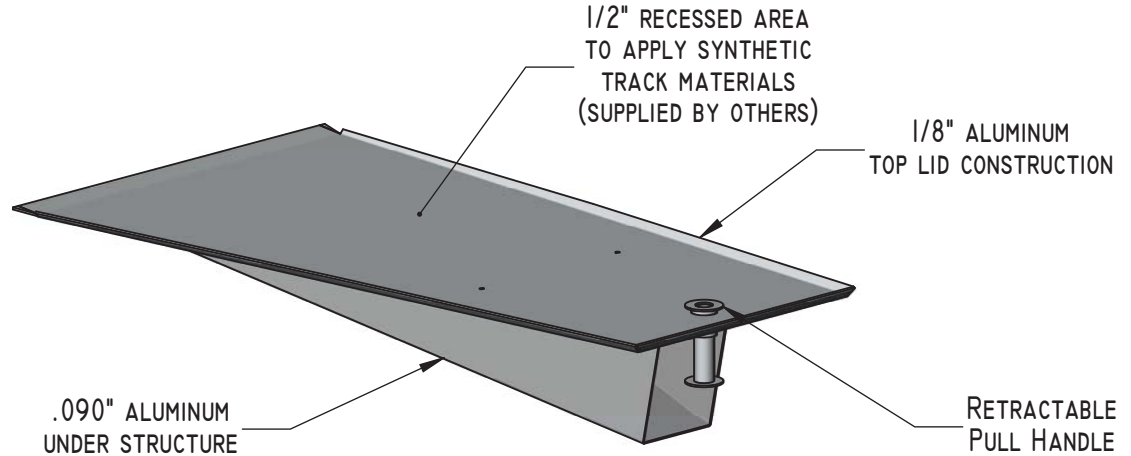

PROPRIETARY AND CONFIDENTIAL

THE INFORMATION CONTAINED IN THIS
DRAWING IS THE SOLE PROPERTY OF
SPORTSFIELD SPECIALTIES INC. ANY
REPRODUCTION IN PART OR AS A WHOLE
WITHOUT THE WRITTEN PERMISSION OF
SPORTSFIELD SPECIALTIES INC. IS
PROHIBITED.

TFPV003ALTR-CA - CAST ALUMINUM VAULT BOX COVER PLUG

NOT TO SCALE

SPORTSFIELD SPECIALTIES INC 11012014

DESIGNED TO MEET THE DEMANDS
OF MODERN SPORTS CONSTRUCTION



41155 ST. HWY 10
PO BOX 231
DELHI, NY 13753
TOLL FREE: 888-975-3343
FAX: 607-746-8481

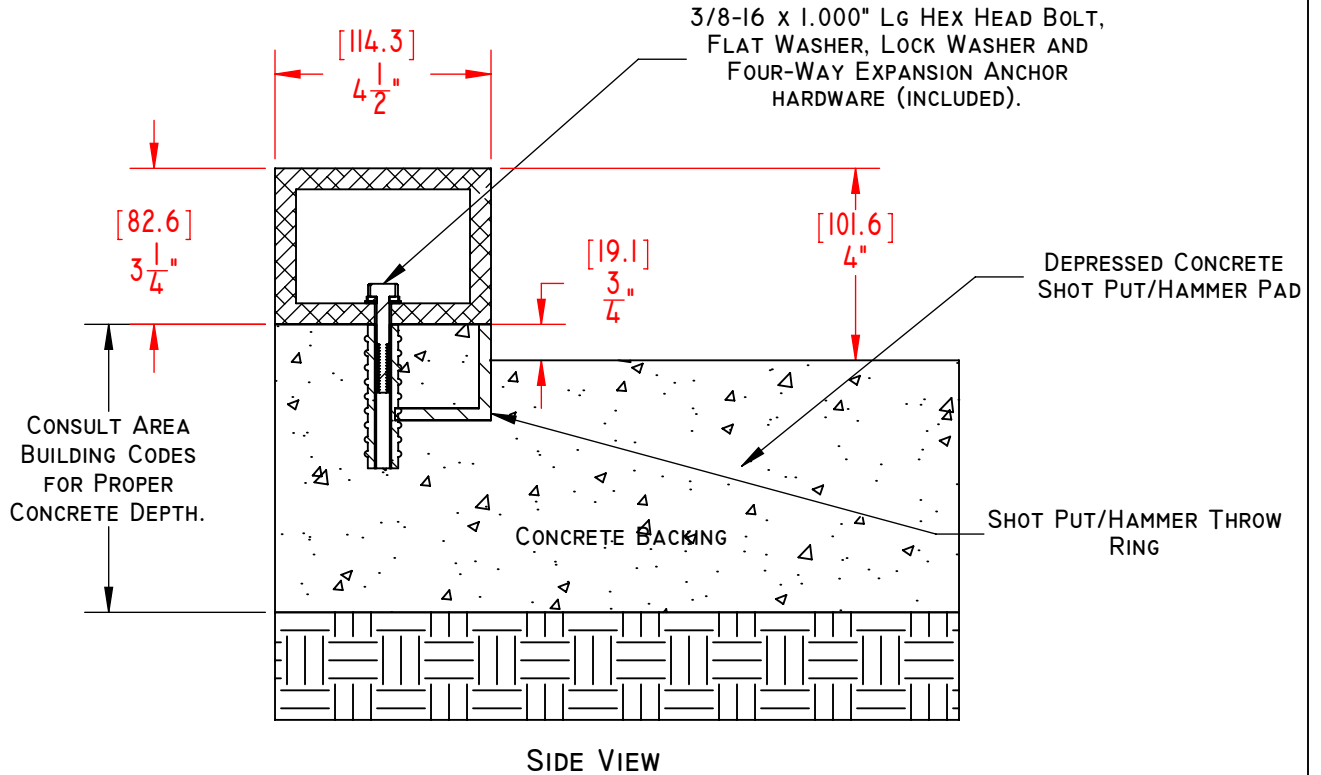
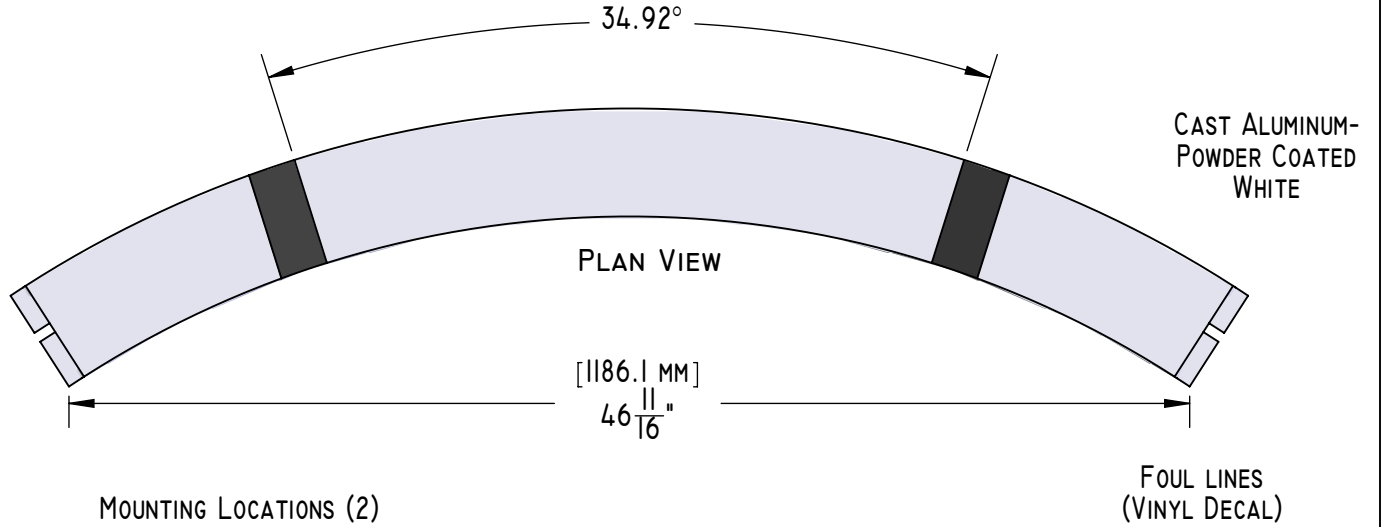

PROPRIETARY AND CONFIDENTIAL

THE INFORMATION CONTAINED IN THIS
DRAWING IS THE SOLE PROPERTY OF
SPORTSFIELD SPECIALTIES INC. ANY
REPRODUCTION IN PART OR AS A WHOLE
WITHOUT THE WRITTEN PERMISSION OF
SPORTSFIELD SPECIALTIES INC. IS
PROHIBITED.

**TFSPT001AL - SHOT PUT TOE BOARD
DEPRESSED PAD INSTALLATION**

NOT TO SCALE

SPORTSFIELD SPECIALTIES INC 11012014

DESIGNED TO MEET THE DEMANDS
OF MODERN SPORTS CONSTRUCTION



41155 ST. HWY 10
PO BOX 231
DELHI, NY 13753
TOLL FREE: 888-975-3343
FAX: 607-746-8481

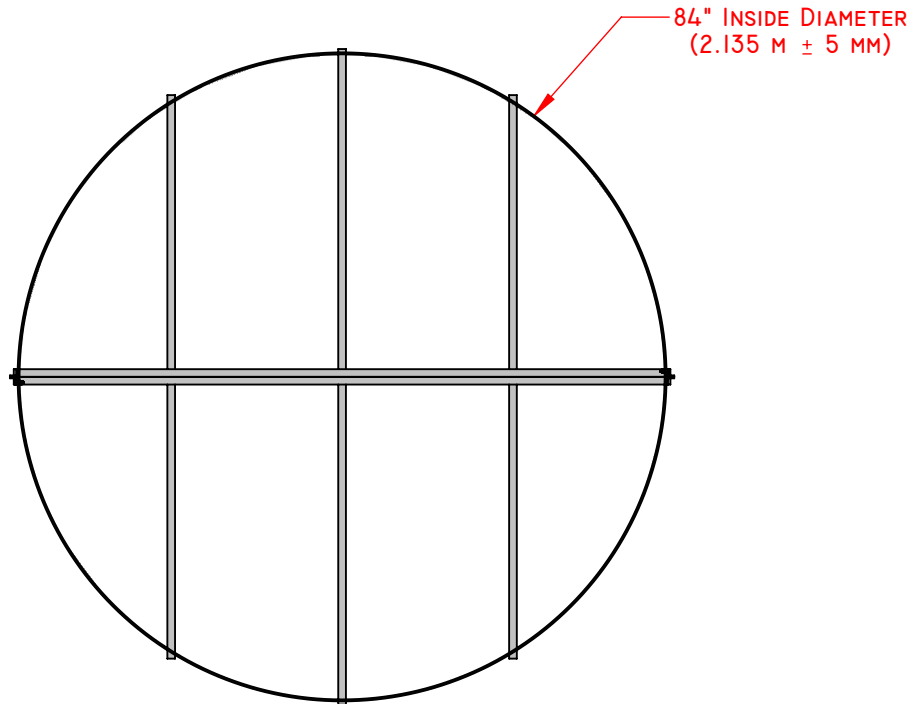

3/4" (0.75") DEPRESSED
CONCRETE FINISHING SCREED LINE

1/4" x 4" ALUMINUM
ROLLED THROW RING

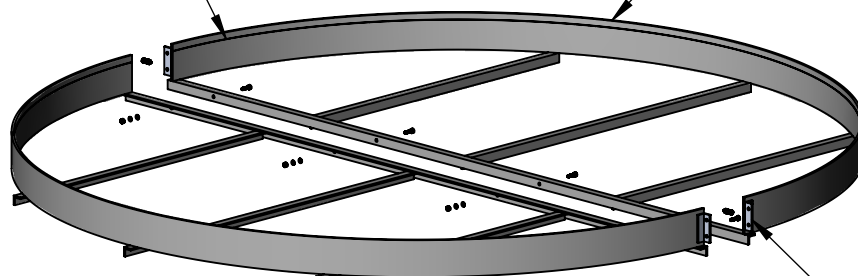

BOLT TOGETHER
CONSTRUCTION
STAINLESS STEEL
HARDWARE INCLUDED

PROPRIETARY AND CONFIDENTIAL

THE INFORMATION CONTAINED IN THIS DRAWING IS THE SOLE PROPERTY OF SPORTSFIELD SPECIALTIES INC. ANY REPRODUCTION IN PART OR AS A WHOLE WITHOUT THE WRITTEN PERMISSION OF SPORTSFIELD SPECIALTIES INC. IS PROHIBITED.

**TFSWRING
SHOT PUT/HAMMER WEB REINFORCED THROW RING**

NOT TO SCALE

SPORTSFIELD SPECIALTIES INC I2112014

DESIGNED TO MEET THE DEMANDS
OF MODERN SPORTS CONSTRUCTION



41155 ST. HWY 10
PO BOX 231
DELHI, NY 13753
TOLL FREE: 888-975-3343
FAX: 607-746-8481

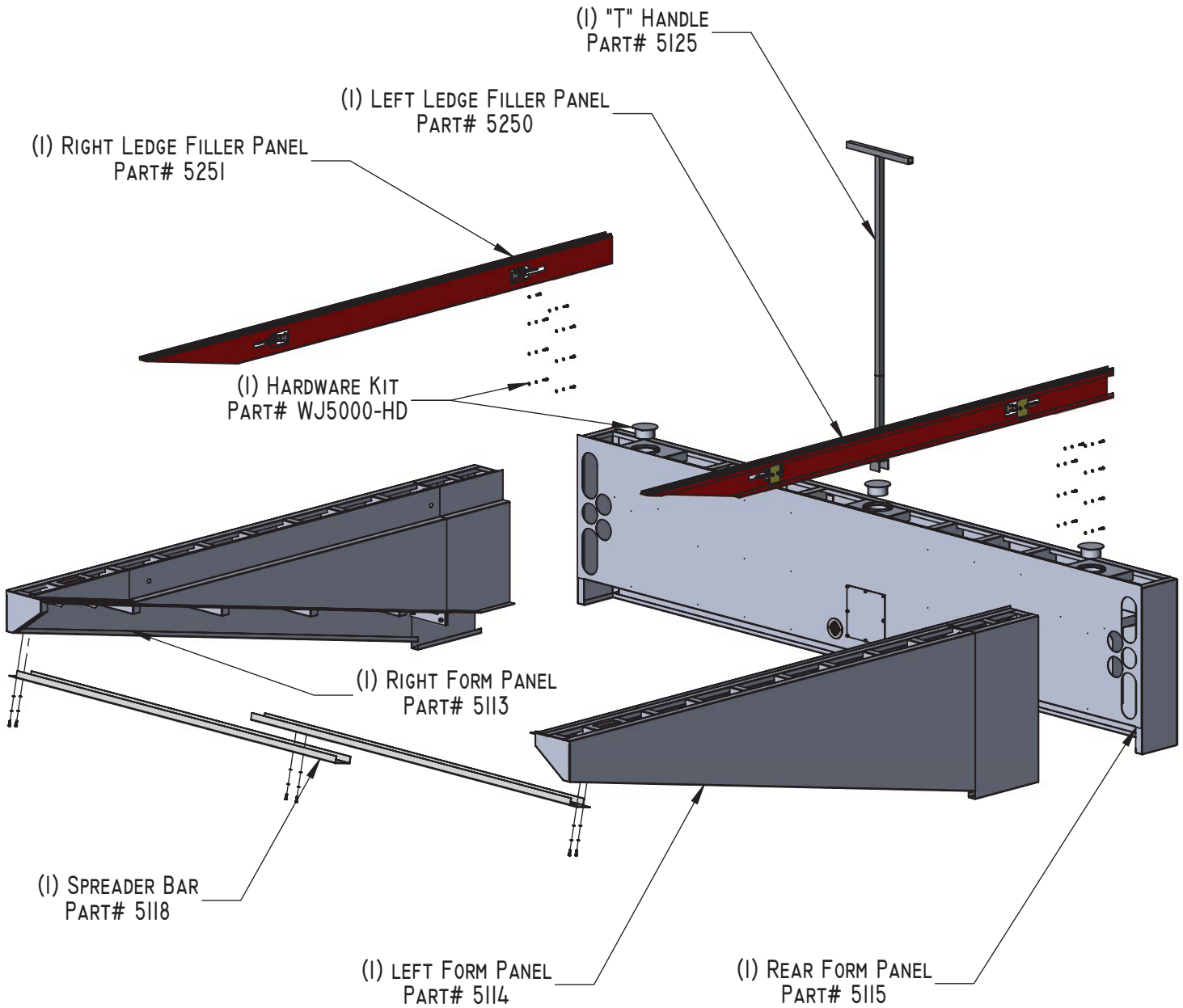

PROPRIETARY AND CONFIDENTIAL

THE INFORMATION CONTAINED IN THIS DRAWING IS THE SOLE PROPERTY OF SPORTSFIELD SPECIALTIES INC. ANY REPRODUCTION IN PART OR AS A WHOLE WITHOUT THE WRITTEN PERMISSION OF SPORTSFIELD SPECIALTIES INC. IS PROHIBITED.

**WJ5000 WATER JUMP PIT
STEEPLECHASE ELEVATION VIEW**

NOT TO SCALE

PRODUCT WEIGHT: 510 LBS.

SPORTSFIELD SPECIALTIES INC 11012014

DESIGNED TO MEET THE DEMANDS
OF MODERN SPORTS CONSTRUCTION



41155 ST. HWY 10
PO BOX 231
DELHI, NY 13753
TOLL FREE: 888-975-3343
FAX: 607-746-8481

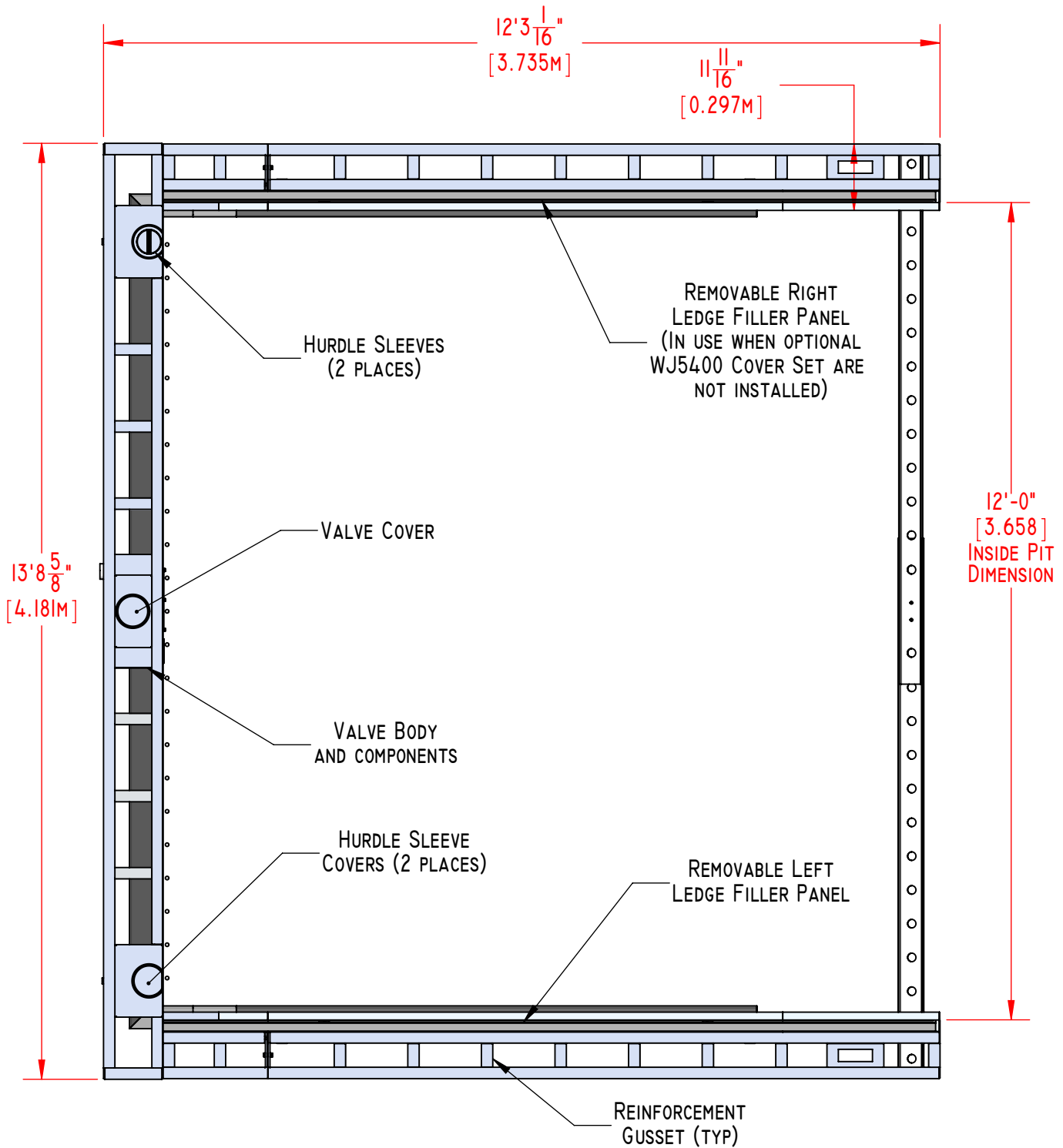

MEETS 2015-2016 N.C.A.A. RULES

NOTE: WJ5000 WATER JUMP PIT IS ALL ALUMINUM CONSTRUCTED.

PROPRIETARY AND CONFIDENTIAL

THE INFORMATION CONTAINED IN THIS DRAWING IS THE SOLE PROPERTY OF SPORTSFIELD SPECIALTIES INC. ANY REPRODUCTION IN PART OR AS A WHOLE WITHOUT THE WRITTEN PERMISSION OF SPORTSFIELD SPECIALTIES INC. IS PROHIBITED.

**WJ5000 WATER JUMP PIT WITH LEDGE FILLERS
PLAN VIEW**

NOT TO SCALE

PRODUCT WEIGHT: 510 LBS.

SPORTSFIELD SPECIALTIES INC 04272015

DESIGNED TO MEET THE DEMANDS
OF MODERN SPORTS CONSTRUCTION



41155 ST. HWY 10
PO BOX 231
DELHI, NY 13753
TOLL FREE: 888-975-3343
FAX: 607-746-8481

WWW.SPORTSFIELDSPECIALTIES.COM

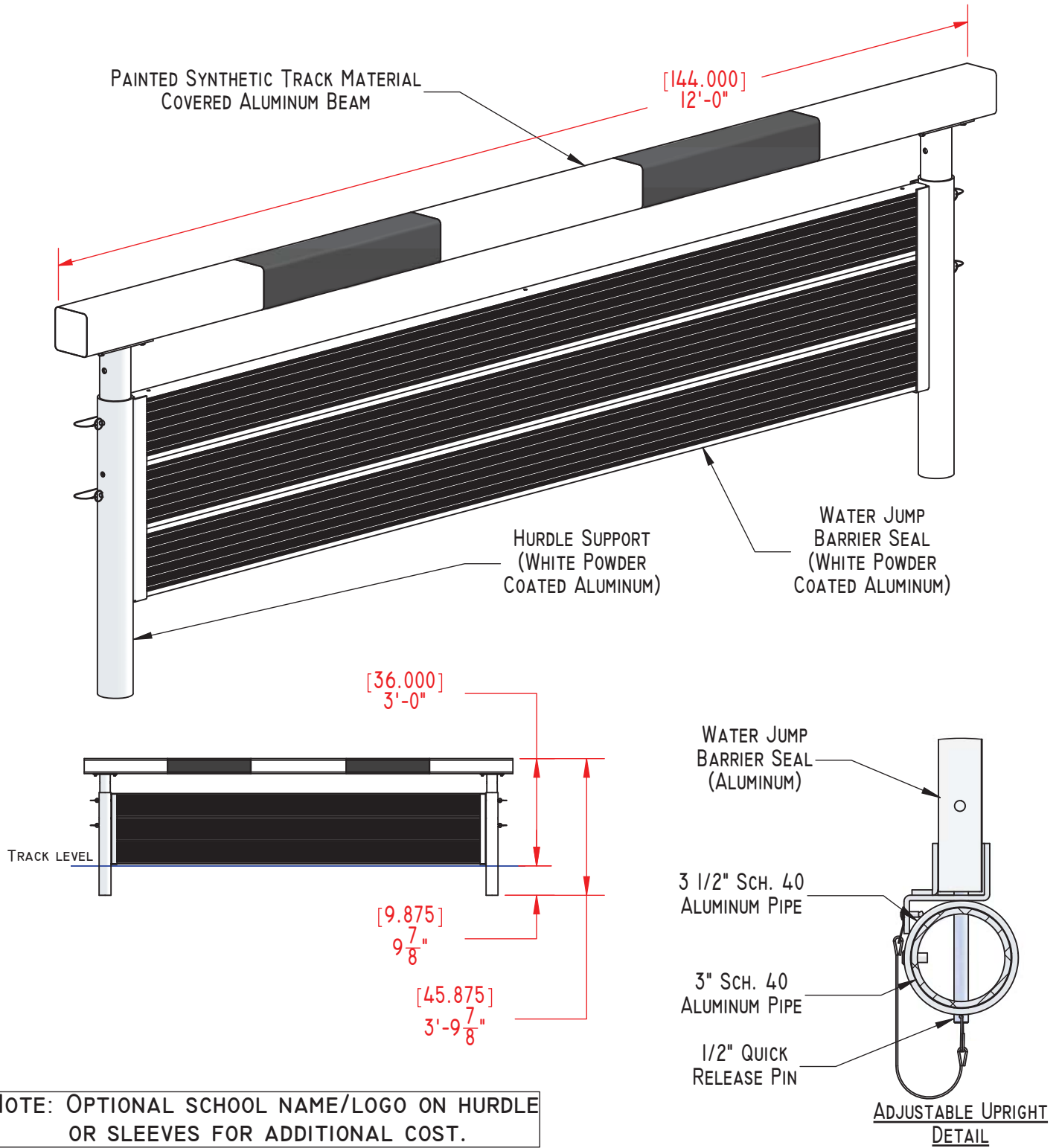

NOTE: OPTIONAL SCHOOL NAME/LOGO ON HURDLE OR SLEEVES FOR ADDITIONAL COST.

PROPRIETARY AND CONFIDENTIAL
THE INFORMATION CONTAINED IN THIS DRAWING IS THE SOLE PROPERTY OF SPORTSFIELD SPECIALTIES INC. ANY REPRODUCTION IN PART OR AS A WHOLE WITHOUT THE WRITTEN PERMISSION OF SPORTSFIELD SPECIALTIES INC. IS PROHIBITED.

ADJUSTABLE STEEPLE CHASE HURDLE WJ5020 PLAN VIEW - MEN'S POSITION

NOT TO SCALE

SPORTSFIELD SPECIALTIES INC 11012014

DESIGNED TO MEET THE DEMANDS
OF MODERN SPORTS CONSTRUCTION



41155 ST. HWY 10
PO BOX 231
DELHI, NY 13753
TOLL FREE: 888-975-3343
FAX: 607-746-8481

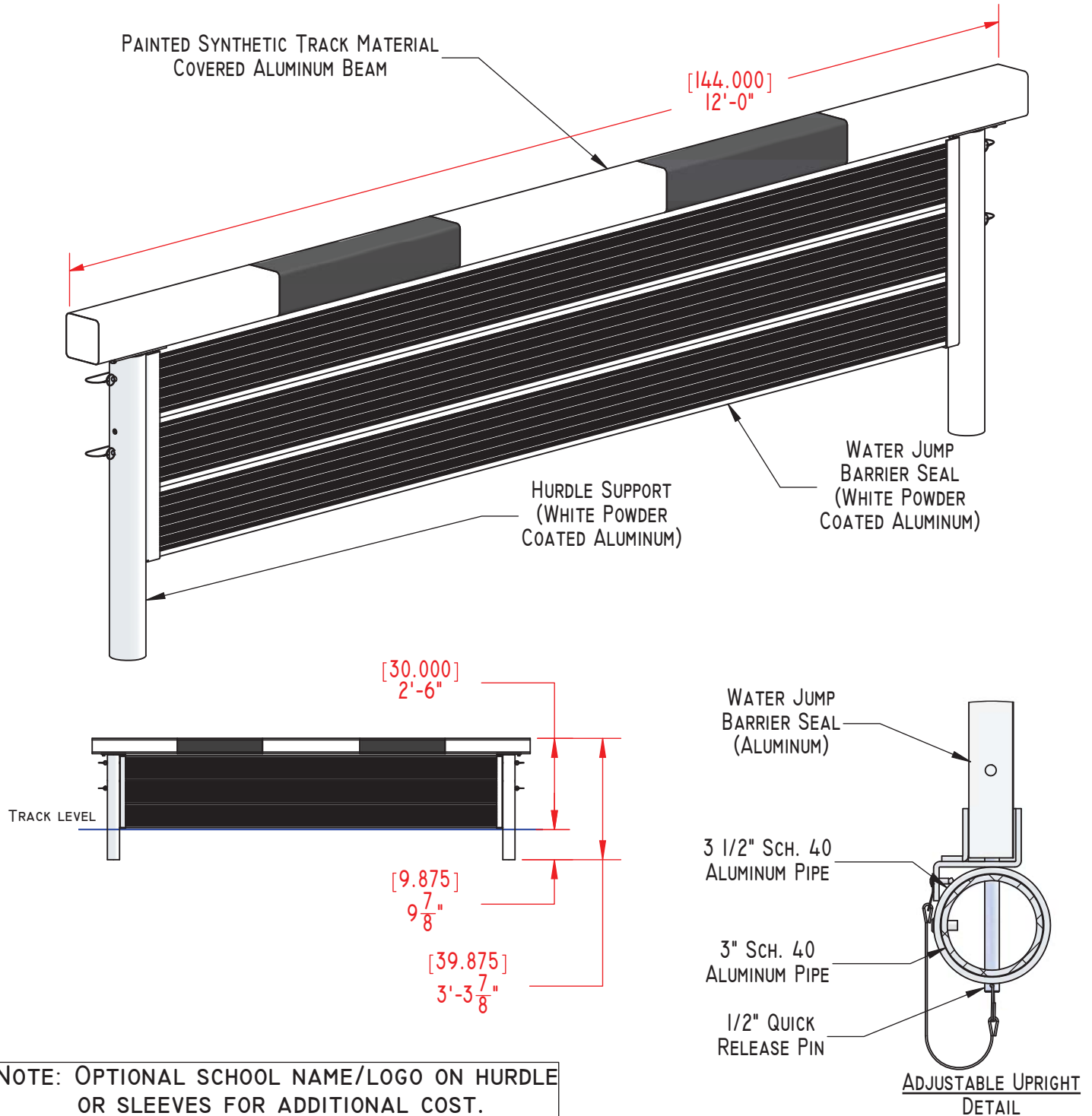

PROPRIETARY AND CONFIDENTIAL
THE INFORMATION CONTAINED IN THIS DRAWING IS THE SOLE PROPERTY OF SPORTSFIELD SPECIALTIES INC. ANY REPRODUCTION IN PART OR AS A WHOLE WITHOUT THE WRITTEN PERMISSION OF SPORTSFIELD SPECIALTIES INC. IS PROHIBITED.

**ADJUSTABLE STEEPLE CHASE HURDLE
WJ5020 PLAN VIEW - WOMEN'S POSITION**

NOT TO SCALE

SPORTSFIELD SPECIALTIES INC 11012014

DESIGNED TO MEET THE DEMANDS
OF MODERN SPORTS CONSTRUCTION

41155 ST. HWY 10
PO BOX 231
DELHI, NY 13753
TOLL FREE: 888-975-3343
FAX: 607-746-8481

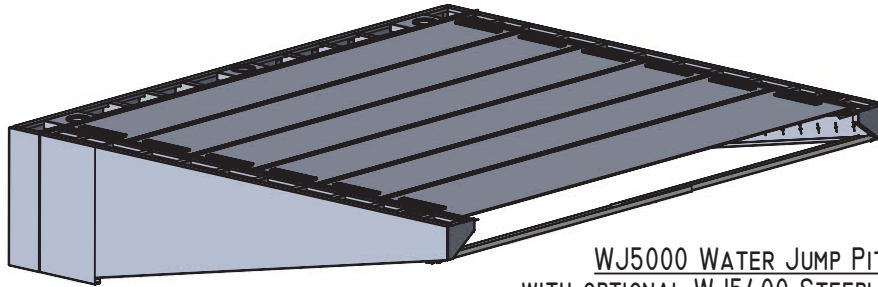

WJ5000 WATER JUMP PIT
WITH OPTIONAL WJ5400 STEEPLECHASE
COVER SET

(5) STANDARD STEEPLECHASE COVER
PART# 5401

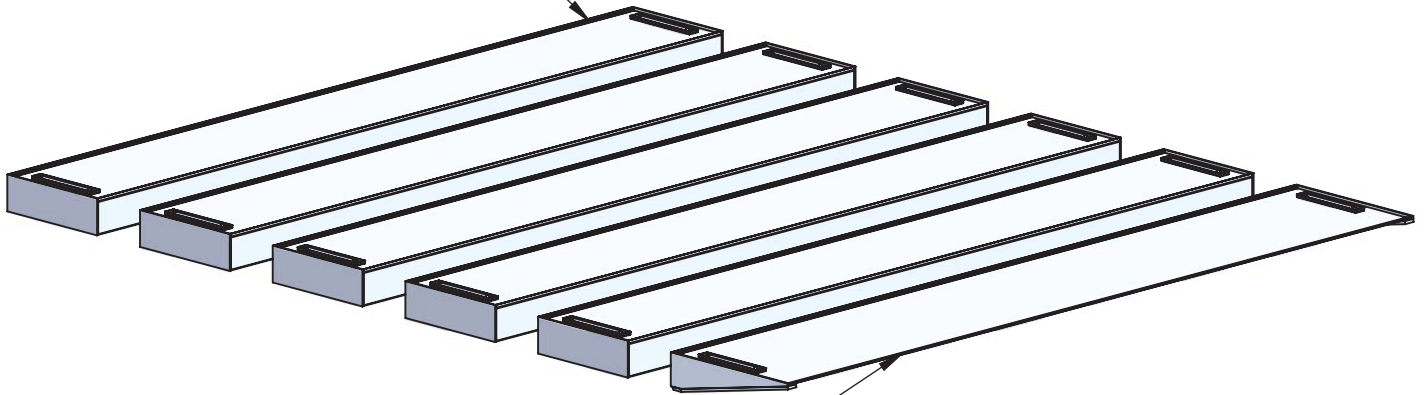

(1) WEDGE COVER
PART# 5402

PROPRIETARY AND CONFIDENTIAL
THE INFORMATION CONTAINED IN THIS
DRAWING IS THE SOLE PROPERTY OF
SPORTSFIELD SPECIALTIES INC. ANY
REPRODUCTION IN PART OR AS A WHOLE
WITHOUT THE WRITTEN PERMISSION OF
SPORTSFIELD SPECIALTIES INC. IS
PROHIBITED.

WJ5400 STEEPLECHASE WATER JUMP PIT PANEL COVER SET

NOT TO SCALE

PRODUCT WEIGHT: 540 LBS.

SPORTSFIELD SPECIALTIES INC 11012014

DESIGNED TO MEET THE DEMANDS
OF MODERN SPORTS CONSTRUCTION



41155 ST. HWY 10
PO BOX 231
DELHI, NY 13753
TOLL FREE: 888-975-3343
FAX: 607-746-8481

WWW.SPORTSFIELDSPECIALTIES.COM

UNITED STATES PATENT # 8,337,318, ISSUED DECEMBER 25, 2012

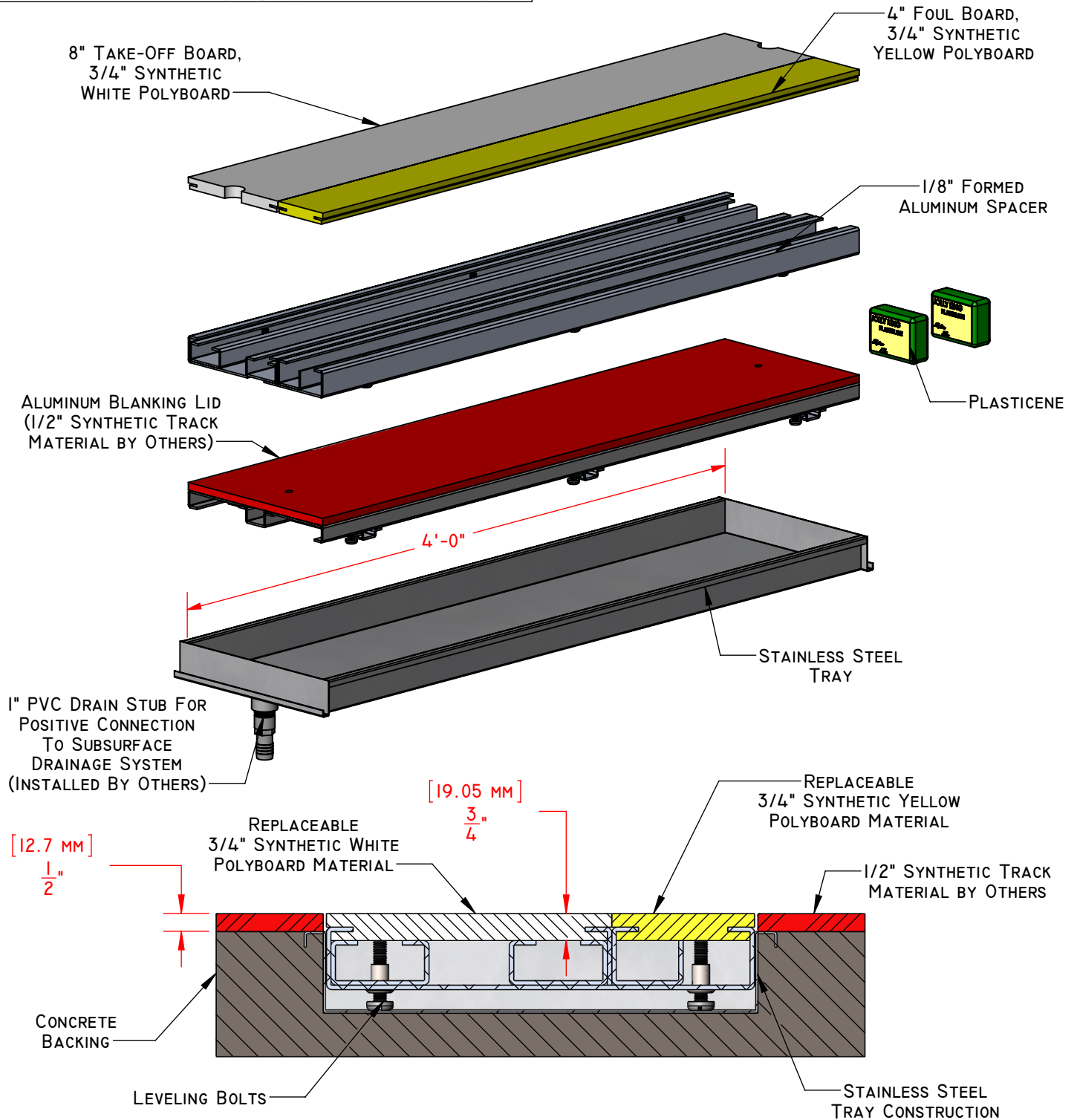

PROPRIETARY AND CONFIDENTIAL
THE INFORMATION CONTAINED IN THIS
DRAWING IS THE SOLE PROPERTY OF
SPORTSFIELD SPECIALTIES INC. ANY
REPRODUCTION IN PART OR AS A WHOLE
WITHOUT THE WRITTEN PERMISSION OF
SPORTSFIELD SPECIALTIES INC. IS
PROHIBITED.

TFLTPO12SS-SYN - 12" LONG/TRIPLE JUMP TAKE-OFF BOARD SYSTEM
WITH REPLACEMENT BLANKING LID

NOT TO SCALE

SPORTSFIELD SPECIALTIES INC 02272015

DESIGNED TO MEET THE DEMANDS
OF MODERN SPORTS CONSTRUCTION



41155 ST. HWY 10
PO BOX 231
DELHI, NY 13753
TOLL FREE: 888-975-3343
FAX: 607-746-8481

SET INCLUDES ALL HARDWARE
AND TWO (2) POST CAPS

2-7/8" OD GALVANIZED
12 GAUGE STEEL

INTERNAL WINDING
MECHANISM WITH
BRASS HAND CRANK

POWDER COATED
BLACK FINISH

[42.00]
3'-6"

3" DIAMETER
PVC GROUND SLEEVES
(SET OF 2)

[16.00]
1'-4"

ACCESSORIES INCLUDED:

- REMOVABLE BRASS HAND CRANK
- TPGS POST GROUND SLEEVES
- TN NET
- TNS NET STRAP
- TNA NET ANCHOR

PROPRIETARY AND CONFIDENTIAL

THE INFORMATION CONTAINED IN THIS
DRAWING IS THE SOLE PROPERTY OF
SPORTSFIELD SPECIALTIES INC. ANY
REPRODUCTION IN PART OR AS A WHOLE
WITHOUT THE WRITTEN PERMISSION OF
SPORTSFIELD SPECIALTIES INC. IS
PROHIBITED.

TSIB INTERNAL WIND TENNIS SYSTEM

NOT TO SCALE

SPORTSFIELD SPECIALTIES INC 08182015

DESIGNED TO MEET THE DEMANDS
OF MODERN SPORTS CONSTRUCTION



41155 ST. HWY 10
PO BOX 231
DELHI, NY 13753
TOLL FREE: 888-975-3343
FAX: 607-746-8481

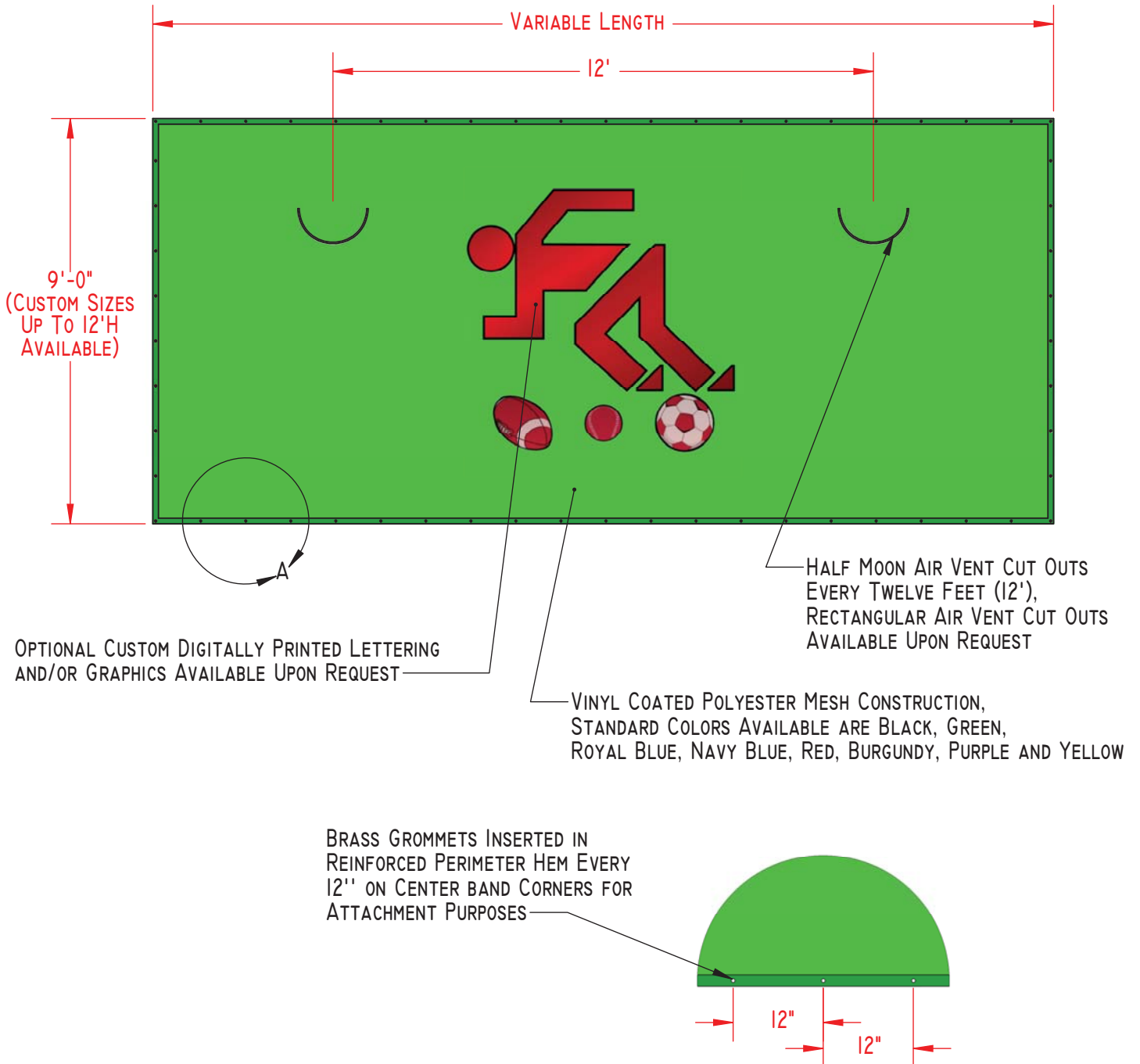

STANDARD PART NUMBERS:

VCP9 - WINDSCREEN 9'H x VARIABLE LENGTH
VCP9-CUSTOM - CUSTOM WINDSCREEN SIZES UP TO 12'H x VARIABLE LENGTH
WDIGITAL - OPTIONAL DIGITALLY PRINTED GRAPHICS AND/OR LETTERING

PROPRIETARY AND CONFIDENTIAL
THE INFORMATION CONTAINED IN THIS
DRAWING IS THE SOLE PROPERTY OF
SPORTSFIELD SPECIALTIES INC. ANY
REPRODUCTION IN PART OR AS A WHOLE
WITHOUT THE WRITTEN PERMISSION OF
SPORTSFIELD SPECIALTIES INC. IS
PROHIBITED.

**VCP9 9'H VINYL COATED POLYESTER MESH
WINDSCREEN MATERIAL**

NOT TO SCALE

SPORTSFIELD SPECIALTIES INC 11012014

DESIGNED TO MEET THE DEMANDS
OF MODERN SPORTS CONSTRUCTION



41155 ST. HWY 10
PO BOX 231
DELHI, NY 13753
TOLL FREE: 888-975-3343
FAX: 607-746-8481



MADE FROM TWO INCH SQUARE (2" x 2") HEAVY GAUGE ALUMINUM TUBE

SECTIONS MEASURE TWENTY FEET (20') IN LENGTH AND ARE
NUMBERED FOR EASE OF INSTALLATION

FORM FITTED AND MANUFACTURED TO EXACT TRACK SPECIFICATIONS
FROM PROVIDED PROJECT LAYOUT DRAWINGS AND INFORMATION,
REQUIRED-BY OTHERS

CURBING SPLITS 1/2" ABOVE SYNTHETIC TRACK SURFACE ON
ANCHOR CLIPS FOR EFFICIENT DRAINAGE

ALUMINUM FINISH IS SILVER OR GOLD ANODIZED (ELECTROPLATED)

IAAF, NCAA, AND USATF RULES COMPLIANT

PROPRIETARY AND CONFIDENTIAL

THE INFORMATION CONTAINED IN THIS
DRAWING IS THE SOLE PROPERTY OF
SPORTSFIELD SPECIALTIES INC. ANY
REPRODUCTION IN PART OR AS A WHOLE
WITHOUT THE WRITTEN PERMISSION OF
SPORTSFIELD SPECIALTIES INC. IS
PROHIBITED.

TF852A - GILL ATHLETICS ANODIZED ALUMINUM TRACK CURB

NOT TO SCALE

SPORTSFIELD SPECIALTIES INC 07262012



TRACK & FIELD

Beard-Eaves-Memorial Coliseum

651 Roosevelt Dr. (36849)

P.O. Box 351

Auburn, AL 36831-0351

phone (334) 844-9750

fax (334) 844-9782

April 29, 2008

To: Phil Lundin, Men's Head Track & Field Coach
Matt Bingle, Women's Head Track & Field Coach
University of Minnesota

From: Ralph Spry, Head Track & Field Coach
Auburn University

Re: Beynon Sports Surfacing

Dear Phil & Matt,

I understand that the University of Minnesota is contemplating a new surface for its track & field complex. Our track at Auburn University has a Beynon Sports Surface and I'd like to share my thoughts on the company with you.

I opted to go with a Beynon track over Mondo for several reasons. First and foremost, I believe it to be a superior product. Our Beynon track has been in place since the fall of 2005 though if you came out to our track today, you would think it had just been poured yesterday. The surface has held up superbly which is why the University of Oregon has opted to go with Beynon as well.

Furthermore, the Beynon track is easier on the athletes. I spoke with several coaches about their tracks and the common consensus was that other surfaces were much harder and injuries were more common place, particularly in colder climates. The poured surface is substantially more forgiving and since our track has been in place stress fractures have become almost non-existent in our program.

Finally, the customer service from Beynon has been outstanding. We have needed no repairs on our track because of the quality of their product, however, Beynon has been there for us all the way. They have gone above and beyond with periodic inspections on the track and maintain great customer relations with Auburn. As we prepare to host the Southeastern Conference Championships, Beynon has sent their professionals out to re-stripe our track and has even offered to provide hospitality for this meet. They have gone the extra mile and continue to be commensurate professionals.

Thanks for your time and if I can be of any help to you, please do not hesitate to contact me.

Sincerely,

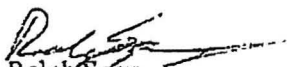
Ralph Spry



BAYLOR



BIG 12 CONFERENCE

TRACK & FIELD

To Whom It May Concern:

During the fall of 2014 our program had the privilege of moving into an amazing new track and field facility on the banks of the Brazos River. The beginning stages of building a new track and field facility began in 2005. After raising the necessary funds and determining the location for this facility, we decided to move forward with the project by investigating surfacing companies. We quickly concluded that John Beynon and his team would be the best fit for the Baylor University Track & Field program. Beynon representatives traveled to Waco many times and went above and beyond to oversee all the details. When the process began last summer we felt adequately informed. One of my favorite memories during the building phase was watching Fermin Mendez and his installation crew painstakingly put in our new BSS 2000 surface, during 100+ degree temperatures in August.

We had the opportunity this spring to host two home competitions and the track performed at the highest standards. We have had only positive feedback from our athletes in their training on it from day to day. I will not forget the smile that Sonya Richards-Ross had on her face following her first workout on the track.

From start to finish the Beynon team has been wonderful to us here at Baylor. The Beynon Staff has been available from the beginning of the project and continues to be easy to contact after the completion of the track. All of us here still have smiles on our faces each day and we owe this to the entire Beynon team. I wholeheartedly endorse Beynon Sports for track surfacing.

Sincerely,

Todd Harbour
Baylor University Track & Field/Cross Country
Head Coach

Birmingham-Southern College
900 Arkadelphia Road
Box 549035
Birmingham, Alabama 35254
205-226-7780
205-226-3059 fax
www.bscc.edu/athletics

To Whom It May Concern:

As a younger coach, I was new to the process of selecting a track surface for our new track facility. As an athlete, I am seasoned in the different qualities of track surfaces. Many surfaces provide the firmness required for fast times, but prove to be too hard for athletes to train on without injury. Other surfaces feel soft to the step, making them wonderful for training, but difficult to run fast during quality competitions. Beynon's BSS 1000 offers the best blend of a soft yet responsive surface at a reasonable price.

Birmingham-Southern College compared many surfaces and the companies that offered them. In an industry overwhelmed with technical jargon, quality assurance issues, and warranty concerns, Beynon Surfaces established themselves as a trustworthy company in every area. They explained exactly what surfaces are recommended for our region and how they would install the product or assist with installation. Beynon offers a great warranty, keeping in touch with their clients regardless of issues. And regarding cost, BSS 1000 is well under the industry standard for such a quality product. Beynon proved to be the better company in every area.

One final area I researched was with larger universities. I found that wealthy institutions, with the ability to use any company they wanted, were choosing Beynon to surface their tracks. Not only were they choosing Beynon for the initial surfacing job, but more importantly, customers were selecting Beynon to resurface their track. This action speaks volumes for the company.

Construction is now underway, and our decision continues to please me. Beynon is attentive, timely, and direct. Our facility will be a top-notch track, largely due to our selection of Beynon's BSS 1000.

Sincerely,

Lars Porter
Head Track Coach





COLBY COLLEGE
5000 Mayflower Hill
Waterville, Maine 04901-8850
TEL 207-859-5000
FAX 207-859-5005

PHYSICAL PLANT DEPARTMENT

February 17, 2014

Re: Reference for Beynon Sports

Dear Sir or Madam,

Beynon Sports installed a BS1000 Hobart Texture Flooring in the Colby College field house in the late summer/fall of 2012. The facility is nearly 50 years old and the work required significant floor prep and attention to detail. Overall, we were very pleased with the service we received from Beynon. The job supervisor, TJ, was excellent and worked closely with us so that the athletic facility hours could be adjusted as needed during the installation. As with any construction projects, things do not always go according to plan and we found that Beynon was responsive to any problems and to our concerns. They have continued to be responsive during our warranty period. I would recommend Beynon Sports for institutions considering similar installations.

Please feel free to contact me if you have any questions or need further information.

Sincerely,

Patricia Crandlemire Whitney, PE, LEED-AP, CEFP
Director of Physical plant



2008 LOCAL ORGANIZING COMMITTEE

P.O. BOX 10825

EUGENE, OR 97440

541.687.1989

August 1, 2008

John Beynon
President
Beynon Sports Surfaces, Inc.
16 Alt Road
Hunt Valley, Maryland 21030

Dear John,

On behalf of the athletes who competed in the 2008 U.S. Olympic Team Trials, thank you for your personal attention to the myriad details associated with building the competition venues at Hayward Field. The upgrades to the facility were a fantastic success and you and your staff played pivotal roles in that outcome.

As you know, we spent many hours researching the perfect athletic surface for the oval, the jumping surfaces, and the throwing venues. I believe that the performances at the 2008 U.S. Olympic Team Trials speak to the work that you and your team dedicated to this project. The jumpers, sprinters, hurdlers, and the distance runners spoke gave us positive feedback about the surface. Based on all of the performances in all of the disciplines, it is clear that we achieved our goal for constructing a high performance facility that also allows adequate recovery between rounds of competition. I appreciate your willingness to respond to our specific and unique needs for Hayward Field.

Your team effectively met the specifications necessary for us to receive the IAAF Class I certificate, and we appreciate the professional manner in which you helped us achieve this very important goal. Additionally, your willingness to do the necessary work on the existing runways at the practice facility was much appreciated by the Eugene community.

Hayward Field will continue to host significant events over the next four years, and we are confident that the experience for the athletes will be heightened as a result of your work. We look forward to a continued partnership with Beynon Sports Surfaces in the future.

Sincerely,

A handwritten signature in black ink, appearing to read 'Vin Lananna'.

Vin Lananna
Co-chair, Eugene 08



**KANSAS
ATHLETICS**
The University of Kansas

February 18, 2014

Rick Ediger
Vice President of Operations
Beynon Sports Surfaces
350 CR 255
Georgetown, TX 78633

Dear Rick:

As an Associate Athletic Director at the University of Kansas, I have had the opportunity to work with Beynon throughout the design, preconstruction and construction phases of two projects in the last few years; Anschutz Sports Pavilion, our indoor track facility and Rock Chalk Park, an IAAF Class I certified outdoor track and field complex.

From the beginning, Beynon project team members gave their full attention to our projects and performed in a professional, client-focused manner throughout both projects. Each individual was dedicated to producing an outstanding product and worked diligently to accomplish this objective. Their quality of work is unequalled. Their experience, dedication and attention to detail throughout all stages of the project were significant to our project's success. Beynon was willing to incorporate all of the last minute changes to the project in order to fulfill the needs of the University, and in doing so, exceeded all of our expectations.

As an NCAA Division I University, logistical planning and coordination are of the utmost importance to our athletic department. It was essential with both of the above mentioned projects that progress was smooth, without interfering with our day-to-day operations of the department. Beynon promised exactly that and delivered on their promise. They consistently put KU's interests first. Beynon also recognized the importance of history and tradition of our intercollegiate program and went beyond a normal scope to ensure our needs were met.

Through their efforts, Beynon provided the University of Kansas Athletic Department with top quality projects that were delivered on time and within budget. I would recommend Beynon and the entire project team for any project they are being considered for.

Sincerely,

Brad Nachtigal
Associate AD – Operations/Capital Projects



NCAA Champions

June 27, 2003

Women's Outdoor1987 • 1988 • 1989
1990 • 1991 • 1992
1993 • 1994 • 1995
1996 • 1997 • 2000**Women's Indoor**1987 • 1989 • 1991
1993 • 1994 • 1995
1996 • 1997 • 2002**Men's Outdoor**1933 • 1989 • 1990
2002**Men's Indoor**

2001

Mr. John Beynon
President/CEO
Beynon Sports Surface, Inc.
1361 Brass Mill Rd., Suite C
Belcamp, MD 21017

Dear John:

I have wanted to communicate with you for some time regarding our facility. As you know we have had your track and field surface here at LSU for the last five years. We are very pleased with the facility. The integrity of the surface as well the wear of the surface has met all our expectations. We have found the surface to be one that is forgiving, which is needed for everyday training and yet a very fast and competitive surface for competition.

We hosted the NCAA Championships in 2002, and received many compliments from coaches and athletes throughout the country. This is a testament and a credit to your company and installer. We enjoyed working with Harry Coke. He is very professional, timely and truly an expert at the business. His attention to details and knowledge of the surface I would say is second to none.

Once again I want to thank you for your prompt service, when needed and your willingness to work with my staff and me.

Thank you,

Pat Henry
Head Track and Field Coach
LSU



Department of Athletics
Stanford University
Stanford, CA 94305-6150
www.gostanford.com

December 11, 2000

A Letter of Recommendation for John Beynon

At the request of Mr. John Beynon, it is my pleasure to comment on his positive relationship with the Stanford Track and Field program.

In 1994, Stanford University completed the installation of a nine lane, 400 meter polyurethane track complete with all of the field event facilities. The project was complicated because the site had been neglected for thirty years, and the dimensions of the available property made the construction difficult to manage. Mr. Beynon and his staff did an outstanding job from the bid process to the construction. His constant follow-up and personal attention to the project was most appreciated. Stanford has been quite pleased with the final product and the professionalism exhibited by the former CEO and President of Martin Surfacing. His knowledge of track and field installations and his integrity were recognized throughout the project.

There are always construction snafus in a project of this magnitude, especially at a private university. Yet, Mr. Beynon was patient, prompt to follow up, and maintained his focus on the details for the duration. His advice was invaluable. Stanford University and our track program now enjoy daily usage of this quality facility. I would support John Beynon as professionally qualified, technically knowledgeable and fiscally responsible.

Sincerely,

Vincent J. Lananna
Director of Track and Field
Stanford University



THE UNIVERSITY
of NORTH CAROLINA
at CHAPEL HILL

DEPARTMENT OF
ATHLETICS

P.O. BOX 2126
SMITH CENTER
SKIPPER BOWLES DRIVE (DELIVERY)
CHAPEL HILL, NC 27515

T 919.962.6000
F 919.962.6002
www.tarheelblue.com

January 20, 2011

To Whom It May Concern:

I write this letter of recommendation for Beynon Sports Surfaces Company and for the person, John Beynon, who is the president of the company. I do this for several reasons, but mainly because a company, regardless of who they are, only provide a great product if they stand behind what they sell.

I am a Track & Field coach with 40 years experience. I coached at UVA before coming to Carolina 26 years ago. John Beynon installed my first track at UVA and he has installed three new tracks here for me at UNC. He has brought his workers here to do "fix-up" repairs which weren't even his company's fault. He calls from time to time and visits the job sites while under construction and time and again once the job is completed. This company is great at doing what is necessary to do to provide a great track surface.

Beynon Surface Co. gives you a product that is extremely durable, very high quality, producing fast times yet protecting the legs, ankles, and knees in male and female athletes. It is a surface that can be used for state, national, and international competition as well as being a great surface for local joggers, P.E. classes, senior citizens, and community activities.

Again, I think Beynon Surfacing is a tremendous product but even more important is the detailed expertise of the installers and the follow up once the job has been completed. There are many companies who can put in a track surface, but very few who service and continue to contact you once they have been paid for doing the job. Good surfaces can and will last ten years, and Beynon's surfaces have done this for me.

I highly recommend Beynon Surfaces Company as a great product and also for their ability to install this product with expertise and professionalism.

Respectfully,

Dennis Craddock
Director of Track & Field
Head Track & Field Coach
UNC – Men & Women

UNIVERSITY OF ALABAMA

"With our renovated track and field complex we will be able to attract the very best recruits and elite athletes to train to train and compete at the Sam Bailey Track complex. The level of competition at our home meets will be significantly improved when other coaches realize they can come to Alabama and have their athletes run on the world's best track surface"

- Dan Waters, Head Coach Track and Field, University of Alabama





UNIVERSITY OF
ILLINOIS
at Urbana-Champaign

WOMEN'S TRACK & FIELD
WOMEN'S CROSS COUNTRY

GARY WINCKLER

Head Coach

The Bielfeldt Athletic Administration Building
1700 South Fourth Street
Champaign, Illinois 61820
(217) 333. 7970
(217) 244. 9758 fax
(217) 762. 7725 home
gwinckle@uiuc.edu E-mail

April 14, 2008

To Whom it may concern:

This letter is to serve as a recommendation for Beynon Sports Surfacing and the work they have done at the University of Illinois. I have known John Beynon for 17 years and have worked with him on numerous track construction and resurfacing projects. I have been very pleased with not only the quality of his work but also, when necessary, the follow up with needed maintenance and repairs. We currently are using Beynon Sport Surfaces on both our indoor and outdoor track facilities and have been very pleased with both the installation and maintenance of those facilities.

I would recommend Beynon Sports Surfacing to anyone considering either a resurfacing or new installation.

Gary Winckler
Head Track & Field Coach
University of Illinois

About Beynon Sports:

Beynon Sports was founded by John T. Beynon with the vision of creating the highest performing synthetic surfaces designed for speed and competition, as well as daily training. Beynon's premier IAAF-Certified track and field surfaces, GreenGuard-certified indoor fieldhouse and gymnasium surfaces and outdoor tennis courts are found in the world's most renowned athletic facilities.

In the spring of 2008, Beynon Sports joined the Tarkett Sports family, combining the most recognized and prestigious name in the artificial turf market in FieldTurf with the celebrated Beynon Sports' branded track and field, fieldhouse and gymnasium surfacing systems. The result is a global firm with unmatched financial strength and a dedication to innovation, customer service, and excellence. Through this partnership, clients receive unprecedented service, quality, and support as well as the financial backing to stand behind the products manufactured and installed.

Beynon Sports is part of Tarkett Sports, a Division of the Tarkett Group. Tarkett Sports is the largest entity in the sports and landscape surfacing industries. Included within the Tarkett Sports portfolio is the world-renowned FieldTurf brand of artificial turf along with an impressive range of performance sports flooring products. This product range includes: synthetic and hardwood basketball; volleyball and gymnasium flooring; squash and racquetball courts; floor protection and covering systems; weight room flooring; and high performance indoor and outdoor running tracks. All Tarkett Sports surfaces are developed, produced and installed with a concentration on sustainability and a commitment to protecting the environment, providing additional LEED contribution opportunities for customers. The company calls this focus on sustainability and the environment 'Environmental Intelligence' and all company personnel strive to exemplify this philosophy in all aspects of the business.

Key Talking Points:

- Industry leader in the design, formulation, production and installation of outdoor track and field, and indoor fieldhouse and gymnasium polyurethane surfaces for high schools, universities and international arenas
- Over 1,500 installations worldwide in the past ten (10) years with over 40 years' experience in the renovation and new construction of sports facilities
- Manufacture over thirty-seven (37) unique polyurethane components for the indoor and outdoor sports surfacing market
- Go to market using a direct installation model, where Beynon Sports' own employees physically construct the surface on-site
- Core markets are North America, Caribbean and Southeast Asia with early-stage share development in India, South America and the European Union

Culture of Beynon Sports:

With the spirit of a start-up and the depth and stability of an industry powerhouse, Beynon Sports provides its employees with the autonomy to execute their objectives in a truly entrepreneurial environment, the resources to master their tasks and the purpose to understand how the effective execution of each individual's responsibilities represents a critical part of the success of the organization.

At Beynon Sports, our team members are dedicated to four core principles:

- **Commitment to the Customer**, which simply means doing what we say we will do.
- **Focus on Financial Strength** to create long-term sustainability. This requires an ever-vigilant focus on cost control, maintenance or expansion of operating margins and avoidance of unquantifiable risks.
- **An Unwavering Emphasis on Operational Excellence** in all aspects of our business – from product formulation to production from estimating to contract management and from construction to close-out.
- **Dedication to the Employee**, which means diligently executing each of our duties thoroughly and conscientiously and the company, in turn, providing fair compensation and benefits and opportunities for career growth and a promoting a healthy balance between our personal and professional lives.

Ownership and Structure:

- Founded in 2001 by John T. Beynon
- Acquired by Tarkett in April 2008
- Beynon is a Division of Tarkett Sports

Approximate Annual Revenues and Number of Employees:

- \$85M USD per year
- 300 employees in the Peak Summer Months

What is the Address of our Headquarters and ISO-9001 Manufacturing Center?

- 16 Alt Road, Hunt Valley, Maryland 21030 (410) 771-9473
Main Contact: Mark Scrivano

Where are Our Operational Centers Located?

- 350 CR 255, Georgetown, Texas 78633
(512) 778-6170
Main Contact: Rick Ediger
- 19600 SW 129th Avenue, Tualatin, Oregon 97062
(503) 563-6396
Main Contact: Rob Gloeckner
- 4263 N Selland Ave, Fresno, California 93722
(559) 840-1585
Main Contact: Mason Farnsworth
- 775 Canosa Ct., Denver, Colorado 80204 (Renner Sports)
(303) 825-3435
Main Contact: Greg McKenna

How Many Installation Teams Do We Have?

- Twenty-four (24) Installation Teams

How Many Regional Sales Offices Do We Have?

- Fourteen (14) Regional Sales Offices Across the United States

How Many Tracks and Fieldhouses Do We Build Each Year?

- Between 180 and 225 facilities each Year Across North America at close to 10.0M square feet of surfacing.
- Including our Partners in the Northeast, close to 275 clients select a Beynon surface each year.

Why Do We Use Distributors in the Northeast?

Due to the increased seasonality in the Northeast, a mature and established market, and the requirement for a Union-designated workforce, Beynon Sports partners with contractors dedicated to the same ideals and levels of workmanship and client satisfaction.

Key Competitive Advantages of Beynon:

- Manufacturer and Installer – Single Source Provider and Warranty.
- Third-Party Insured Warranty on All Projects (Only Track Manufacturer and Installer who can provide this).
- Bonding Capacity.
 - Ability to bond a single project up to \$20,000,000
 - Aggregate bonding capacity at \$75,000,000
- Seven (7) IAAF Certified Systems – Solution to Meet Any Budget
- Customization.
 - All surfaces are designed, manufactured and installed to the precise durometer and force reduction desired
 - All polyurethane products are made in Hunt Valley, Maryland, USA
- Leading Builder in North America with >50% Market Share.
- Access to SmartBuy Cooperative Purchasing.

Why is SmartBuy such a Great Tool for the Client?

- Control: Get the Beynon surface you want without leaving anything to chance.
- Speed: No purchasing process is faster from proposal-> contract. Period.
- Simplicity: Single contract, sole-source responsibility, no General Contracting mark-up.
- Value: Secure the team, schedule and terms of your choosing.
- Savings: Time, energy and confusion of the bid process is greatly reduced.



FAST TRACK
Maintenance Program

We make you **look Good.**



Inspections

Who can you trust to give you the full story? Our team of certified, experienced experts will conduct a full inspection of your track facility to determine its condition.

Repairs

Does your track have a few problem areas? Our FastTrack team can repair any issues that you are having with your track with efficiency and perfection.



Resurfacing

Has your track seen better days? Resurfacing your track surface extends its life span for a fraction of the cost of replacing it.

Restripping

Not sure which lane your running in? It's time to restripe your track. Let our experts bring your lines back to life.



FIND OUT MORE

Beynon Sports
4263 N. Selland Ave., Fresno, CA 93722
559-840-1585 | www.beynonSports.com



THE ULTIMATE
SURFACE EXPERIENCE

Plexipave Court Reference list

Project	Installation Dates	Owner Contact Information
1.) Centralia High School 813 Eshom Rd. Centralia, WA 98531	May 2010 August 2010	Brian Eko, Director of Facilities & Maintenance P. 360-330-7644 E. beko@centralia.wednet.edu
2.) Athey Creek Middle School 2900 SW Borland Rd West Linn, OR 97068	July 2009 August 2009	Joel Sebastian, Principal P. 503-673-7400 E. sebastij@wlwv.k12.or.us
3.) Horizon Middle School 3915 S Pines Rd Spokane, WA 99206	June 2008 August 2008	Jesse Hardt P. 509-228-4940 E. jhardt@cvsd.org
4.) Omak High School 20 S. Cedar St Omak, WA 98841	June 2008 August 2008	David Kirk, Principal P. 509-826-8515 E. dkirk@omaksd.org
5.) Mountlake Terrace HS 21801 44 th Ave W. Mountlake Terrace, WA 98043	July 2007 August 2007	Debra Dodge P. 425-431-7153 E. dodge@edmonds.wednet.edu

FELONY CONVICTION NOTICE

Statutory citation covering notification of criminal history of contractor is found in the Texas Education Code #44.034. Following is an example of a felony conviction notice:

State of Texas Legislative Senate Bill No. 1, Section 44.034, Notification of Criminal History, Subsection (a), states "a person or business entity that enters into a contract with a school district or ESC 8/TIPS must give advance notice to the district or ESC 8/TIPS if the person or an owner or operator of the business entity has been convicted of a felony. The notice must include a general description of the conduct resulting in the conviction of a felony."

Subsection (b) states "a school district may terminate a contract with a person or business entity if the district determines that the person or business entity failed to give notice as required by Subsection (a) or misrepresented the conduct resulting in the conviction. The district must compensate the person or business entity for services performed before the termination of the contract."

THIS NOTICE IS NOT REQUIRED OF A PUBLICLY-HELD CORPORATION

Complete only one of the three below: A or B or C.

I, the undersigned agent for the firm named below, certify that the information concerning notification of felony convictions has been reviewed by me and the following information furnished is true to the best of my knowledge.

Official: Eric Dalier
Print Authorized Company Official's Name

A. My firm is a publicly held corporation; therefore, this reporting requirement is not applicable.

Signature of Authorized Company Official: _____

B. My firm is not owned nor operated by anyone who has been convicted of a felony:

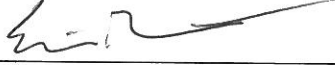
Signature of Authorized Company Official:  _____

C. My firm is owned or operated by the following individual(s) who has/have been convicted of a felony:

Name of Felon(s): _____

Details of Conviction(s): _____

Signature of Authorized Company Official: _____

CERTIFICATION BY CORPORATE OFFERER

IF OFFERER IS A CORPORATION,

THE FOLLOWING CERTIFICATE SHOULD BE EXECUTED AND INCLUDED AS PART OF PROPOSAL FORM/PROPOSAL FORM.

OFFERER: FieldTurf USA, Inc.
(Name of Corporation)

I, Marie-France Nantel ^{Assistant} certify that I am the Secretary of the Corporation
(Name of Corporate Secretary) (Name of Assistant Corporate Secretary)

named as OFFERER herein above; that

Eric Dalier
(Name of person who completed proposal document)

who signed the foregoing proposal on behalf of the corporation offerer is the authorized person that is acting as

President
(Title/Position of person signing proposal/offer document within the corporation)

of the said Corporation; that said proposal/offer was duly signed for and in behalf of said corporation by authority of its governing body, and is within the scope of its corporate powers.

CORPORATE SEAL



SIGNATURE

February 21, 2017

DATE

Federal Requirements for Procurement and Contracting with small and minority businesses, women's business enterprises, and labor surplus area firms.

The Education Service Center Region 8 and TIPS anticipate possibly using federal funds for procurement under this potential award and is required to obtain the following compliance assurance.

1. Will you be subcontracting any of your work under this award if you are successful? (Circle one)

YES or NO

2. If yes, do you agree to comply with the following federal requirements? (Circle one)

YES or NO

2 CFR §200.321 Contracting with small and minority businesses, women's business enterprises, and labor surplus area firms.

(a) The non-Federal entity must take all necessary affirmative steps to assure that minority businesses, women's business enterprises, and labor surplus area firms are used when possible.

(b) Affirmative steps must include:

- (1) Placing qualified small and minority businesses and women's business enterprises on solicitation lists;
- (2) Assuring that small and minority businesses, and women's business enterprises are solicited whenever they are potential sources;
- (3) Dividing total requirements, when economically feasible, into smaller tasks or quantities to permit maximum participation by small and minority businesses, and women's business enterprises;
- (4) Establishing delivery schedules, where the requirement permits, which encourage participation by small and minority businesses, and women's business enterprises;
- (5) Using the services and assistance, as appropriate, of such organizations as the Small Business Administration and the Minority Business Development Agency of the Department of Commerce ; and
- (6) Requiring the prime contractor, if subcontracts are to be let, to take the affirmative steps listed in paragraphs (1) through (5) of this section.

Company Name FieldTurf USA, Inc.

Print name of authorized representative Eric Daliere

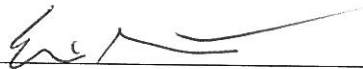
Signature of authorized representative 

Date February 21, 2017

FAILURE TO PROPERLY COMPLETE THIS FORM AND SUBMIT WITH YOUR RESPONSE MAY RESULT IN A WAIVER OF YOUR RIGHTS UNDER THE LAW TO MAINTAIN CONFIDENTIALITY TREATMENT OF SUBMITTED MATERIALS.

CONFIDENTIAL INFORMATION SUBMITTED IN RESPONSE TO COMPETITIVE PROCUREMENT REQUESTS OF EDUCATION SERVICE CENTER REGION 8 AND TIPS IS GOVERNED BY TEXAS GOVERNMENT CODE, CHAPTER 552

If you consider any portion of your proposal to be confidential information and not subject to public disclosure pursuant to Chapter 552 Tex Gov't Code or other law(s), **you must make a copy of all claimed confidential materials within your proposal and put this COMPLETED form as a cover sheet to said materials then scan, name "CONFIDENTIAL" and upload with your proposal submission.** (You must include the confidential information in the submitted proposal as well, the copy uploaded is to indicate which material in your proposal, if any, you deem confidential in the event the District receives a Public Information Request.) Education Service Center Region 8 and TIPS will follow procedures of controlling statute(s) regarding any claim of confidentiality and shall not be liable for any release of information required by law. Pricing of solicited product or service may be deemed as public information under Chapter 552 Tex Gov't Code. The Office of Texas Attorney General shall make the final determination whether the information held by Education Service Center Region 8 and TIPS is confidential and exempt from public disclosure.

I DO NOT desire to expressly waive any claim of confidentiality as to any and all information contained within our response to the competitive procurement process (e.g. RFP, CSP, Bid, RFQ, etc.) by completing the following and submitting this sheet with our response to Education Service Center Region 8 and TIPS. The attached contains material from our proposal that I classify and deem confidential under Texas Gov't Code Sec. 552 or other law(s) and I invoke my statutory rights to confidential treatment of the enclosed materials:

Name of company claiming confidential status of material

Printed Name, Title, and Signature of authorized company officer claiming confidential status of material

Address City State ZIP Phone

ATTACHED ARE COPIES OF _____ PAGES OF CONFIDENTIAL MATERIAL FROM OUR PROPOSAL

Express Waiver: I desire to expressly waive any claim of confidentiality as to any and all information contained within our response to the competitive procurement process (e.g. RFP, CSP, Bid, RFQ, etc.) by completing the following and submitting this sheet with our response to Education Service Center Region 8 and TIPS.

FieldTurf USA, Inc.

Name of company expressly waiving confidential status of material

Eric Dalieri, President. 

Printed Name, Title, and Signature of authorized company officer expressly waiving confidential status of material

7445 Cote-de-Liesse, Suite 200 Montreal QC H4T 1G2 (800) 724-2969

Address City State ZIP Phone



January 27, 2017

**Re: Fieldturf USA, Inc.
Contractor Prequalification**

To Whom This May Concern:

Please be advised that Federal Insurance Company, a member of the Chubb Group of Insurance Companies, has had the privilege of bonding Fieldturf USA, Inc. since 2000. They are licensed and authorized to do business in all states. They have a Treasury Listing of \$1,186,080,000 and are rated A++ by A. M. Best with a Financial Size XV.

Federal Insurance Company has extended surety credit to Fieldturf in an aggregate amount of \$75,000,000, with a single job limit of \$10,000,000. However, these numbers do not represent the largest amount that the surety would consider. Fieldturf is completing all current projects in a satisfactory manner and has never defaulted on a project. Federal Insurance Company has never had to intervene in or complete any of Fieldturf USA, Inc.'s projects.

It is our understanding that Fieldturf USA, Inc. has or will be submitting a proposal to you for the referenced project. We anticipate no problem in providing, should they be awarded, a 100% Performance and Payment bond in the full amount of the proposal. As always, the surety reserves the right to perform normal underwriting at the time of any bond request, including without limitation to, prior review and approval of relevant contract terms and conditions, bond forms, appropriate contract funding and any other underwriting considerations at the time of the request. Our consideration and issuance of bonds is a matter solely between Fieldturf USA, Inc. and ourselves, and we assume no liability to third parties or to you by the issuance of this letter.

We appreciate having the opportunity to share with you our experience with this fine company and urge you to give them every consideration. Please contact me should you have any questions regarding this valued customer.

Sincerely,

Jeffrey M. Wilson
Senior Vice President - Surety
McGriff, Seibels & Williams, Inc.



Manufacturer's Limited Warranty

FieldTurf warrants that if **FieldTurf** FTRV-1 (Product) for multi-sport use synthetic turf proves to be defective in material or installation workmanship, UV degradation, resulting in premature wear, during normal and ordinary use of the Product for the sporting activities provided herein or for any other uses for which FieldTurf provides its written authorization, within eight (8) years from the date of completion of installation (as indicated in this Warranty), FieldTurf shall either repair or replace the affected area of the Product in accordance with the terms of this Warranty. FieldTurf's sole liability under this Warranty shall be limited to either repair or replacement of the affected area of the Product, at its sole discretion, and FieldTurf shall have no other obligations or liabilities with respect to defects of the Product. FieldTurf will, at FieldTurf's option, either repair or replace the affected area to the extent required to meet the Warranty period, but no cash refunds will be made. **FieldTurf** warrants that all materials installed meet or exceed the product specifications and further warrants that replacement material will be available through the Warranty period. **FieldTurf** will verify that their representative has inspected the installation and that the work conforms to **FieldTurf's** requirements and further warrants that the installation was done in accordance with both **FieldTurf's** recommendations and any written directives of FieldTurf's representative. This Warranty shall commence upon the date of completion indicated in this Warranty. The accompanying Warranty service will not come into effect unless and until FieldTurf's Certificate of Completion is sent for validation to the corporate office of FieldTurf indicated herein within thirty (30) days of the date of completion or Purchaser's first use, whichever occurs first. In all cases, the Warranty shall be deemed to commence upon the date of completion indicated in this Warranty. The acceptance form of the terms and conditions contained in FieldTurf's Maintenance Guidelines must also be provided to FieldTurf's corporate office within thirty (30) days of completion of installation. **FieldTurf** warrants that the G-max to maintain a value of below 135 at installation and no greater than 185 for the life of the warranty, as per ASTM 1936 and F-355 standards, providing that the customer has performed the regular maintenance as outlined in the maintenance guidelines. This Warranty is limited to the remedies of repair or replacement, which shall constitute the exclusive remedies available under this Warranty; all other remedies or recourse which might otherwise be available are hereby waived by the Purchaser. FieldTurf will have no other obligations or liability for damages arising out of or in connection with the use or performance of the Product, including, without limitation, damages for personal injury and/or economic losses. This Warranty shall not come into effect, and FieldTurf shall have no obligations under this Warranty, unless and until FieldTurf is paid in full for the Product to be warranted hereunder.

Field Markings: Football, Soccer

Other Exclusions

EXCEPT AS EXPRESSLY SET FORTH IN THE MANUFACTURER'S LIMITED WARRANTY ABOVE, FIELDTURF DISCLAIMS ALL OTHER WARRANTIES OF ANY KIND, EXPRESS OR IMPLIED, IN FACT OR IN LAW, INCLUDING, BUT NOT LIMITED TO, THE IMPLIED WARRANTIES OF MERCHANTABILITY AND FITNESS FOR A PARTICULAR PURPOSE.

THIS WARRANTY SHALL BECOME NULL AND VOID IF THE PURCHASER FAILS TO MAINTAIN THE FIELD IN ACCORDANCE WITH THE FIELDTURF MAINTENANCE GUIDELINES AND SCHEDULE PROVIDED BY FIELDTURF THEREIN. ALL MAINTENANCE SHALL BE PERFORMED BY FIELDTURF-TRAINED AND/OR FIELDTURF-AUTHORIZED MAINTENANCE PERSONNEL ONLY.

Furthermore, this Manufacturer's Limited Warranty **does not cover**:

1. Damage resulting from accident, *force majeure*, misuse, intentional and unintentional abuse, infill displacement, and neglect or from other than normal play and ordinary use of the Product. For purposes of this Warranty, normal play and ordinary use shall mean usage up to 3,000 hours per year of regular play and utilization for the sporting activities provided herein; normal play and ordinary use also includes a reasonable number of users or participants, but does not include repetitive marching, repetitive training or high-intensity drills on the same part of the field, especially in the areas of, but not limited to, home plate, pitcher's mound, base areas, base paths, soccer penalty mark/spot areas, goal areas, sideline areas and lacrosse crease areas, all of which require frequent maintenance in accordance with FieldTurf Maintenance Guidelines and may require regular replacement.

This warranty is insured by a third party.

For more information please contact Customer Service at FieldTurf at the number listed below.
7445 Côte-de-Liesse Road Suite 200, Montreal, QC, Canada H4T 1G2 • Toll Free: 1-800-724-2969 •





Manufacturer's Limited Warranty

2. Damage resulting from failure to maintain the Product in accordance with FieldTurf's Maintenance Guidelines provided to the Purchaser. The Purchaser shall keep a log of all maintenance performed on the Product and supply FieldTurf with a copy upon request.
3. Damage resulting from repair, attempted repair and/or maintenance by anyone other than FieldTurf or an authorized FieldTurf distributor or authorized FieldTurf maintainer.
4. Damage due to causes which include, but are not limited to, the application of chemicals and/or cleaning agents, adhesive backing, dirt, traffic, negligence, vandalism, fire, flood, windstorm, animals, improper care and Acts of God.
5. Failure and/or improper design of the base; depression of the soil, subsurface or other matter upon which the base or Product rests; and any and all resulting damage to the Product arising therefrom.
6. FieldTurf does not warrant the percolation rate, long term planarity and/or compaction of the base which the product is installed. **FIELDTURF DISCLAIMS ALL WARRANTIES AS TO THE BASE, EXPRESS OR IMPLIED, AND ANY AND ALL RESULTING DAMAGE TO THE PRODUCT ARISING THEREFROM.**
7. Damage resulting from the use of improper footwear such as long-spiked track shoes, regular and repeated use of steel cleats, and flat-soled shoes. Standard molded soccer or football cleats are recommended.

All synthetic turf is subject to normal wear and tear, which is not a manufacturing defect and is not covered by this Warranty. In addition to the other factors listed in this Warranty, wear and tear depends on, without limitation, the construction of synthetic turf (fiber face weight, stitch rate, fiber pile height and gauge, infill components and maintenance of the field) and the intensity of use of the synthetic turf. The Product will be stable to light fading with the maximum fading of the Product during the Warranty period not to exceed fifteen percent (15%) of color loss annually based upon an acceptable grey scale. This Warranty does not cover slight variations or gradations of color within the Product and/or face distortion. Normal behavior of the fiber and infill with respect to the wear pattern of a field can be found in the "Field Settling" document, provided in the FieldTurf after-sales service package.

FieldTurf disclaims all liability for incidental and consequential damages for breach of any express or implied warranty, including any implied warranty of merchantability, with respect to the Product. In the event that the Product is used for purposes other than the sporting activities provided herein or any other uses for which FieldTurf gives its written authorization, it being understood that FieldTurf has tested the Product for use in connection with these sporting activities and may not have tested it for other uses, FieldTurf shall not be responsible for any and all damages incurred and the Manufacturer's Limited Warranty, as well as all legal warranties, shall become null and void. Any Product repairs or replacements performed under the terms of this Warranty shall not extend the term of this Warranty.

Name of Purchaser:		<input type="text"/>	
Date of completion:	<input type="text"/>	Sporting Activities:	<input type="text" value="Multi-Sport use"/>
Location:	<input type="text"/>	Installed by:	<input type="text" value="FieldTurf USA Inc."/>
Address:	<input type="text"/>	City:	<input type="text"/>
State:	<input type="text"/>	Zip:	<input type="text"/>
Tel:	<input type="text"/>	Fax:	<input type="text"/>
Signature:	<input type="text"/>	(Please Print Name)	<input type="text" value="Darren Gill"/>
Date:	<input type="text" value="November 1st, 2015"/>	Reference:	<input type="text" value="0000"/>

This warranty is insured by a third party.

For more information please contact Customer Service at FieldTurf at the number listed below.
7445 Côte-de-Liesse Road Suite 200, Montreal, QC, Canada H4T 1G2 • Toll Free: 1-800-724-2969 •





Manufacturer's Limited Warranty

FieldTurf warrants that if **FieldTurf** FTRV-1F (Product) for multi-sport use synthetic turf proves to be defective in material or installation workmanship, UV degradation, resulting in premature wear, during normal and ordinary use of the Product for the sporting activities provided herein or for any other uses for which FieldTurf provides its written authorization, within eight (8) years from the date of completion of installation (as indicated in this Warranty), FieldTurf shall either repair or replace the affected area of the Product in accordance with the terms of this Warranty. FieldTurf's sole liability under this Warranty shall be limited to either repair or replacement of the affected area of the Product, at its sole discretion, and FieldTurf shall have no other obligations or liabilities with respect to defects of the Product. FieldTurf will, at FieldTurf's option, either repair or replace the affected area to the extent required to meet the Warranty period, but no cash refunds will be made. FieldTurf warrants that all materials installed meet or exceed the product specifications and further warrants that replacement material will be available through the Warranty period. FieldTurf will verify that their representative has inspected the installation and that the work conforms to FieldTurf's requirements and further warrants that the installation was done in accordance with both FieldTurf's recommendations and any written directives of FieldTurf's representative. Warranty shall commence upon the date of completion indicated in this Warranty. The accompanying Warranty service will not come into effect unless and until FieldTurf's Certificate of Completion is sent for validation to the corporate office of FieldTurf indicated herein within thirty (30) days of the date of completion or Purchaser's first use, whichever occurs first. In all cases, the Warranty shall be deemed to commence upon the date of completion indicated in this Warranty. The acceptance form of the terms and conditions contained in FieldTurf's Maintenance Guidelines must also be provided to FieldTurf's corporate office within thirty (30) days of completion of installation. **FieldTurf** warrants that the G-max to maintain a value of below 135 at installation and no greater than 185 for the life of the warranty, as per ASTM 1936 and F-355 standards, providing that the customer has performed the regular maintenance as outlined in the maintenance guidelines. This Warranty is limited to the remedies of repair or replacement, which shall constitute the exclusive remedies available under this Warranty; all other remedies or recourse which might otherwise be available are hereby waived by the Purchaser. FieldTurf will have no other obligations or liability for damages arising out of or in connection with the use or performance of the Product, including, without limitation, damages for personal injury and/or economic losses. This Warranty shall not come into effect, and FieldTurf shall have no obligations under this Warranty, unless and until FieldTurf is paid in full for the Product to be warranted hereunder.

For the designated high-traffic areas (Home Plate, Pitcher's Mound, Base areas, Base Paths) and all synthetic turf installed anywhere on the infield, the above-noted warranty applies except that the applicable warranty period shall be limited to a two (2) year manufacturer's warranty.

Field Markings: Baseball, Softball

Other Exclusions

EXCEPT AS EXPRESSLY SET FORTH IN THE MANUFACTURER'S LIMITED WARRANTY ABOVE, FIELDTURF DISCLAIMS ALL OTHER WARRANTIES OF ANY KIND, EXPRESS OR IMPLIED, IN FACT OR IN LAW, INCLUDING, BUT NOT LIMITED TO, THE IMPLIED WARRANTIES OF MERCHANTABILITY AND FITNESS FOR A PARTICULAR PURPOSE.

THIS WARRANTY SHALL BECOME NULL AND VOID IF PURCHASER FAILS TO MAINTAIN THE FIELD IN ACCORDANCE WITH THE FIELDTURF MAINTENANCE GUIDELINES AND SCHEDULE PROVIDED BY FIELDTURF THEREIN. ALL MAINTENANCE SHALL BE PERFORMED BY FIELDTURF-TRAINED AND/OR FIELDTURF-AUTHORIZED MAINTENANCE PERSONNEL ONLY.

Furthermore, this Manufacturer's Limited Warranty **does not cover**:

1. Damage resulting from accident, *force majeure*, misuse, intentional and unintentional abuse, infill displacement, and neglect or from other than normal play and ordinary use of the Product. For purposes of this Warranty, normal play and ordinary use shall mean usage up to 3,000 hours per year of regular play and utilization for the sporting activities provided herein; normal play and ordinary use also includes a reasonable number of users or participants, but does not include repetitive marching, repetitive training or high-intensity drills on the same part of the field, especially in the areas of, but not limited to, home plate, pitcher's mound, base areas, base paths all of which require frequent maintenance in accordance with FieldTurf Maintenance Guidelines and may require regular replacement.
2. Damage resulting from failure to maintain the Product in accordance with the baseball specific maintenance and use instructions provided to the buyer. Given the nature of baseball, this warranty shall be conditional upon the owner carrying out regular baseball specific field maintenance as specified in FieldTurf's applicable maintenance manuals/guidelines and maintaining written logs showing same. The owner understands the particular baseball requirement for frequent in-fill replenishment and maintenance on bases, base paths and anywhere else in-fill is naturally displaced.

This warranty is insured by a third party.

For more information please contact Customer Service at FieldTurf at the number listed below.
7445 Côte-de-Liesse Road Suite 200, Montreal, QC, Canada H4T 1G2 • Toll Free: 1-800-724-2969 •





Manufacturer's Limited Warranty

3. Damage resulting from repair, attempted repair and/or maintenance by anyone other than FieldTurf or an authorized FieldTurf distributor or authorized FieldTurf maintainer.
4. Damage due to causes which include, but are not limited to, the application of chemicals and/or cleaning agents, adhesive backing, dirt, traffic, negligence, vandalism, fire, flood, windstorm, animals, improper care and Acts of God.
5. Failure and/or improper design of the base; depression of the soil, subsurface or other matter upon which the base or Product rests; and any and all resulting damage to the Product arising therefrom.
6. FieldTurf does not warrant the percolation rate, long term planarity and/or compaction of the base which the product is installed. **FIELDTURF DISCLAIMS ALL WARRANTIES AS TO THE BASE, EXPRESS OR IMPLIED, AND ANY AND ALL RESULTING DAMAGE TO THE PRODUCT ARISING THEREFROM.**
7. Damage resulting from the use of improper footwear such as long-spiked track shoes, regular and repeated use of steel cleats, and flat-soled shoes. Standard molded soccer or football cleats are recommended.

All synthetic turf is subject to normal wear and tear, which is not a manufacturing defect and is not covered by this Warranty. In addition to the other factors listed in this Warranty, wear and tear depends on, without limitation, the construction of synthetic turf (fiber face weight, stitch rate, fiber pile height and gauge, infill components and maintenance of the field) and the intensity of use of the synthetic turf. The Product will be stable to light fading with the maximum fading of the Product during the Warranty period not to exceed fifteen percent (15%) of color loss annually based upon an acceptable grey scale. This Warranty does not cover slight variations or gradations of color within the Product and/or face distortion. Normal behavior of the fiber and infill with respect to the wear pattern of a field can be found in the "Field Settling" document, provided in the FieldTurf after-sales service package.

FieldTurf disclaims all liability for incidental and consequential damages for breach of any express or implied warranty, including any implied warranty of merchantability, with respect to the Product. In the event that the Product is used for purposes other than the sporting activities provided herein or any other uses for which FieldTurf gives its written authorization, it being understood that FieldTurf has tested the Product for use in connection with these sporting activities and may not have tested it for other uses, FieldTurf shall not be responsible for any and all damages incurred and the Manufacturer's Limited Warranty, as well as all legal warranties, shall become null and void. Any Product repairs or replacements performed under the terms of this Warranty shall not extend the term of this Warranty.

Name of Purchaser:			
Date of completion:		Sporting Activities:	Multi-Sport Use
Location:		Installed by:	FieldTurf USA
Address:		City:	
State:		Zip:	
Tel:		Fax:	
Signature:		(Please Print Name)	Darren Gill
Date:	December 15 th , 2015	Reference:	0000

This warranty is insured by a third party.

For more information please contact Customer Service at FieldTurf at the number listed below.
7445 Côte-de-Liesse Road Suite 200, Montreal, QC, Canada H4T 1G2 • Toll Free: 1-800-724-2969 •



TRACK WARRANTY (FULL DEPTH)

Beynon Sports Surfaces guarantees the installation of the rubber athletic surface to be free from defects in materials and workmanship for a period of (5) years from completion of installation. Should any defect occur, repairs will be made free of charge. This guarantee covers only the work performed by Beynon Sports Surfaces.

The guarantee covers track and field use only, and shall not be interpreted as holding Beynon Sports Surfaces responsible for any deterioration of the work due to normal use or the abuses of the installation. Abuse of the installation specifically includes, but is not limited to:

- 1) Use of the track by motor vehicles or equipment.
- 2) Use of the track for other than track and field activity (i.e. parades, assembly, and bleachers).
- 3) Damage to the surface caused by football, soccer, or baseball.
- 4) Vandalism.

The owner acknowledges that the sub-base and the base are a completely separate installation and are not covered by this guarantee. This guarantee does not cover the base asphalt or problems in the Beynon rubber track surface which are a result of defect, cracking, shifting or deterioration of the base asphalt or vegetation growth through the base asphalt.

The track striping, when provided by Beynon Sports Surfaces is guaranteed as above to be free from defects in materials and workmanship. Fading due to normal use is excluded.

This warranty is the exclusive and sole remedy of the owner. Prior to warranty being effective, all bills associated with the installation of the track system must be paid in full.

Beynon Sports Surfaces

Project

Date

MAINTENANCE TRACK SURFACE WARRANTY

Beynon Sports Surfaces. guarantees the installation of the rubber athletic surface to be free from defects in materials and workmanship for a period of (1) one year from completion of installation. Should any defect occur, repairs will be made free of charge. This guarantee covers only the work performed by Beynon Sports Surfaces.

The guarantee covers track and field use only, and shall not be interpreted as holding Beynon Sports Surfaces responsible for any deterioration of the work due to normal use or the abuses of the installation. Abuse of the installation specifically includes, but is not limited to:

- 1) Use of the track by motor vehicles or equipment.
- 2) Use of the track for other than track and field activity (i.e. parades, assembly, and bleachers).
- 3) Damage to the surface caused by football, soccer, or baseball.
- 4) Vandalism.

The owner acknowledges that the sub-base and the base are a completely separate installation and are not covered by this guarantee. This guarantee does not cover the base asphalt or problems in the Beynon rubber track surface which are a result of defect, cracking, shifting or deterioration of the base asphalt or vegetation growth through the base asphalt.

The track striping, when provided by Beynon Sports Surfaces is guaranteed as above to be free from defects in materials and workmanship. Fading due to normal use is excluded.

This warranty is the exclusive and sole remedy of the owner. Prior to warranty being effective, all bills associated with the installation of the track system must be paid in full.

Beynon Sports Surfacing

Project

Date

COURT WARRANTY

Beynon Sports Surfaces and California Products Corp. guarantees the installation of the tennis court surface to be free from defects in materials and workmanship for a period of (1) one year from completion of installation. Should any defect occur, repairs will be made free of charge. This guarantee covers only the materials and work performed by Beynon Sports Surfaces and their sub-contractors.

The guarantee covers tennis court use only, and shall not be interpreted as holding Beynon Sports Surfaces or California Products Corp. responsible for any deterioration of the work due to normal use or the abuses of the installation. Abuse of the installation specifically includes, but is not limited to:

- 1) Use of the tennis/basketball court by motor vehicles or equipment.
- 2) Use of the tennis court for other than tennis activity.
- 3) Damage to the surface caused by vandalism.

The owner acknowledges that the sub-base and the base are a completely separate installation and are not covered by this guarantee. This guarantee does not cover the base asphalt/concrete or problems in the court surfacing system which are a result of defect, cracking, shifting or deterioration of the base asphalt/concrete or vegetation growth through the base asphalt/concrete.

The court striping, when provided by Beynon Sports surfaces is guaranteed as above to be free from defects in materials and workmanship. Fading due to normal use is excluded.

This warranty is the exclusive and sole remedy of the owner. Prior to warranty being effective, all bills associated with the installation of the court system must be paid in full.

Beynon Sports Surfaces California Products Corp.

Project

Date

CERTIFICATE OF INTERESTED PARTIES

FORM 1295

1 of 1

Complete Nos. 1 - 4 and 6 if there are interested parties.
 Complete Nos. 1, 2, 3, 5, and 6 if there are no interested parties.

**OFFICE USE ONLY
 CERTIFICATION OF FILING**

Certificate Number:
 2017-178340

Date Filed:
 03/14/2017

Date Acknowledged:

1 Name of business entity filing form, and the city, state and country of the business entity's place of business.

FieldTurf USA, Inc.
 Montreal Quebec Canada

2 Name of governmental entity or state agency that is a party to the contract for which the form is being filed.

Region 8 Education Service Center

3 Provide the identification number used by the governmental entity or state agency to track or identify the contract, and provide a description of the services, goods, or other property to be provided under the contract.

RCSP 170205
 Synthetic or Natural Sports Fields, Courts or Tracks (JOC)

4	Name of Interested Party	City, State, Country (place of business)	Nature of interest (check applicable)	
			Controlling	Intermediary

5 Check only if there is NO Interested Party.



6 AFFIDAVIT

I swear, or affirm, under penalty of perjury, that the above disclosure is true and correct.

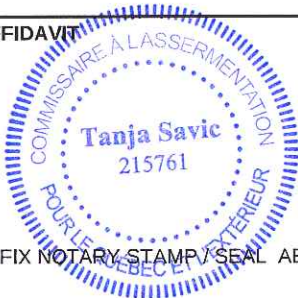

[Handwritten Signature]

Signature of authorized agent of contracting business entity

AFFIX NOTARY STAMP/ SEAL ABOVE

Sworn to and subscribed before me, by the said Darren Gill, this the 14 day of March, 20 17, to certify which, witness my hand and seal of office.

[Handwritten Signature]
 Signature of officer administering oath

Tanja Savic
 Printed name of officer administering oath

Paralegal
 Title of officer administering oath



AMERICAN SPORTS BUILDERS ASSOCIATION

*Through Its Certification Board
Has Conferred Upon*

Jeff Yoos

The Designation

CERTIFIED FIELD BUILDER - Synthetic Turf

*FOR EFFORTS TO RAISE THE PROFESSIONAL
STANDARDS OF FIELD CONSTRUCTION AND
FOR HAVING SUCCESSFULLY FULFILLED THE
CONDITIONS OF ELIGIBILITY AND PASSED THE
REQUIRED EXAMINATION.*

In witness whereof we have set our hands on

this 31st day of December, 2014

Certification valid for a period of 3 years.

Executive Vice President

Certification Chairman





AMERICAN SPORTS BUILDERS ASSOCIATION

*Through Its Certification Board
Has Conferred Upon*

Todd Grimes

The Designation

CERTIFIED TRACK BUILDER



FOR EFFORTS TO RAISE THE PROFESSIONAL
STANDARDS OF RUNNING TRACK CONSTRUCTION
AND FOR HAVING SUCCESSFULLY FULFILLED THE
CONDITIONS OF ELIGIBILITY AND PASSED THE
REQUIRED EXAMINATION.

In witness whereof we have set our hands on
this 31st day of December, 2015

Certification valid for a period of 3 years.

Executive Vice President

Certification Chairman