

TIPS VENDOR AGREEMENT

Between _____ and
(Company Name)

THE INTERLOCAL PURCHASING SYSTEM (TIPS)

For

RFP 170302 Furniture, Furnishings and Services

General Information

The Vendor Agreement (“Agreement”) made and entered into by and between The Interlocal Purchasing System (hereinafter referred to as “TIPS” respectfully) a government cooperative purchasing program authorized by the Region 8 Education Service Center, having its principal place of business at 4845 US Hwy 271 North, Pittsburg, Texas 75686. This Agreement consists of the provisions set forth below, including provisions of all Attachments referenced herein. In the event of a conflict between the provisions set forth below and those contained in any Attachment, the provisions set forth shall control.

The vendor Agreement shall include and incorporate by reference this Agreement, the terms and conditions, special terms and conditions, any agreed upon amendments, as well as all of the sections of the solicitation as posted, including any addenda and the awarded vendor’s proposal. Once signed, if an awarded vendor’s proposal varies or is unclear in any way from the TIPS Agreement, TIPS, at its sole discretion, will decide which provision will prevail. Other documents to be included are the awarded vendor’s proposals, task orders, purchase orders and any adjustments which have been issued. If deviations are submitted to TISP by the proposing vendor as provided by and within the solicitation process, this Agreement may be amended to incorporate any agreed deviations.

The following pages will constitute the Agreement between the successful vendors(s) and TIPS. Bidders shall state, in a separate writing, and include with their proposal response, any required exceptions or deviations from these terms, conditions, and specifications. If agreed to by TIPS, they will be incorporated into the final Agreement.

Definitions

PURCHASE ORDER is the TIPS member’s approval providing the authority to proceed with the negotiated delivery order under the Agreement. Special terms and conditions as agreed to between the vendor and TIPS member will be added as addendums to the PO. Items such as certificate of insurance, bonding requirements, small or disadvantaged business goals are some of the addendums possible.

Terms and Conditions

Freight

All quotes to members shall provide a line item for cost for freight or shipping regardless if there is a charge or not. If no charge for freight or shipping, indicate by stating "No Charge" or "\$0" or other similar indication.

Warranty Conditions

All supplies equipment and services shall include manufacturer's minimum standard warranty unless otherwise agreed to in writing. Vendor shall be an authorized dealer, distributor or manufacturer for all products. All equipment proposed shall be new unless clearly stated in writing.

Customer Support

The Vendor shall provide timely and accurate customer support to TIPS members. Vendors shall respond to such requests within one (1) working day after receipt of the request. Vendor shall provide training regarding products and services supplied by the Vendor unless otherwise clearly stated in writing at the time of purchase. (Unless training is a line item sold or packaged and must be purchased with product.)

Agreements

All Agreements and agreements between Vendors and TIPS Members shall strictly adhere to the statutes that are set forth in the Uniform Commercial Code as most recently revised.

Agreements for purchase will normally be put into effect by means of a purchase order(s) executed by authorized agents of the participating government entities.

Davis Bacon Act requirements will be met when Federal Funds are used for construction and/or repair of buildings.

Tax exempt status

A taxable item sold, leased, rented to, stored, used, or consumed by any of the following governmental entities is exempted from the taxes imposed by this chapter:(1) the United States; (2) an unincorporated instrumentality of the United States; (3) a corporation that is an agency or instrumentality of the United States and is wholly owned by the United States or by another corporation wholly owned by the United States;(4) the State of Texas; (5) a Texas county, city, special district, or other political subdivision; or (6) a state, or a governmental unit of a state that borders Texas, but only to the extent that the other state or governmental unit exempts or does not impose a tax on similar sales of items to this state or a political subdivision of this state. Texas Tax Code § 151.309.

Assignments of Agreements

No assignment of Agreement may be made without the prior written approval of TIPS. Payment can only be made to the awarded Vendor or vendor assigned dealer.

Disclosures

1. Vendor affirms that he/she has not given, offered to give, nor intends to give at any time hereafter any economic opportunity, future employment, gift, loan, gratuity, special discount, trip, favor or service to a public servant in connection with this Agreement.
2. Vendor shall attach, in writing, a complete description of any and all relationships that might be considered a conflict of interest in doing business with participants in the TIPS program.
3. The vendor affirms that, to the best of his/her knowledge, the offer has been arrived at independently, and is submitted without collusion with anyone to obtain information or gain any favoritism that would in any way limit competition or give an unfair advantage over other vendors in the award of this Agreement.

Renewal of Agreements

The Agreement with TIPS is for one (1) year with an option for renewal for additional consecutive years as provided in the solicitation. Total term of Agreement can be up to the number of years provided in the solicitation, if sales are reported through the Agreement and both parties agree.

Automatic Renewal Clauses Incorporated in Awarded Vendor Agreements with TIPS Members Resulting from the Solicitation and with the Vendor Named in this Agreement.

No Agreement for goods or services with a TIPS member by the awarded vendor named in this Agreement that results from the solicitation award named in this Agreement, may incorporate an automatic renewal clause with which the TIPS member must comply. All renewal terms incorporated in an Agreement by the vendor with the TIPS member shall only be valid and enforceable when the vendor receives written confirmation by purchase order or executed Agreement issued by the TIPS member for any renewal period. The purpose of this clause is to avoid a TIPS member inadvertently renewing an Agreement during a period in which the governing body of the TIPS member has not properly appropriated and budgeted the funds to satisfy the Agreement renewal. This term is not negotiable and any Agreement between a TIPS member and a TIPS awarded vendor with an automatic renewal clause that conflicts with these terms is rendered void and unenforceable.

Shipments

The Vendor shall ship ordered products within a commercially reasonable time after the receipt of the order. If a product cannot be shipped within that time, the Vendor shall notify TIPS and

the requesting entity as to why the product has not shipped and shall provide an estimated shipping date, if applicable. TIPS or the requesting entity may cancel the order if estimated shipping time is not acceptable.

Invoices

The Vendor or vendor assigned dealer shall submit invoices, to the TIPS participant. Each invoice shall include the TIPS participant's purchase order number. The shipment tracking number or pertinent information for verification of TIPS participant receipt shall be made available upon request. The Vendor or vendor assigned dealer shall not invoice for partial shipments unless agreed to in writing in advance by TIPS and the TIPS participant.

Payments

The TIPS participant will make payments directly to the Vendor or vendor assigned dealer at net 30 days after receiving invoice.

Pricing

The Vendor agrees to provide pricing to TIPS and its participating governmental entities that is at least equal to the lowest pricing available to like cooperative purchasing customers and the pricing shall remain so throughout the duration of the Agreement.

The Vendor agrees to promptly lower the cost of any product purchased through TIPS following a reduction in the manufacturer or publisher's direct cost to the Vendor. Price increases will be honored according to the terms of the solicitation. However, the Vendor shall honor previous prices for thirty (30) days after written notification to TIPS of an increase.

All pricing submitted to TIPS shall include the participation fee, as provided in the solicitation, to be remitted to TIPS by the Vendor. Vendor will not show adding the fee to the invoice presented to customer. Failure to render the participation fee to TIPS shall constitute a breach of this agreement and shall be grounds for termination of this agreement and any other agreement held with TIPS.

Participation Fees

Vendor or vendor assigned dealer Agreements to pay the participation fee for all Agreement sales to TIPS on a monthly scheduled report. Vendor must login to the TIPS database and use the "Submission Report" section to report sales. The Vendor or vendor assigned dealers are responsible for keeping record of all sales that go through the TIPS Agreement. Failure to pay the participation fee will result in termination of Agreement. Please contact TIPS at tips@tips-usa.com or call (866) 839-8477 if you have questions about paying fees.

Indemnity

- 1. Indemnity for Personality Agreements.** Vendor agrees to indemnify and hold harmless and defend TIPS, TIPS member(s), officers and employees, from and against all claims and suits for damages, injuries to persons (including death), property damages, losses, and expenses including court costs and attorney's fees, arising out of, or resulting from, Vendor's performance of this Agreement, including all such causes of action based upon common, constitutional, or statutory law, or based in whole or in part, upon allegations of negligent or intentional acts on the part of the Vendor, its officers, employees, agents, subcontractors, licensees, invitees, whether or not such claims are based in whole or in part upon the negligent acts or omissions of the TIPS, TIPS member(s), officers, employees, or agents.
- 2. Indemnity for Performance Agreements.** The Vendor agrees to indemnify and hold harmless and defend TIPS, TIPS member(s), officers and employees from and against all claims and suits for damages, injuries to persons (including death), property damages, losses, and expenses including court costs and attorney's fees, arising out of, or resulting from, Vendor's work under this Agreement, including all such causes of action based upon common, constitutional, or statutory law, or based in whole or in part, upon allegations of negligent or intentional acts on the part of the Vendor, its officers, employees, agents, subcontractors, licensees, or invitees. Vendor further agrees to indemnify and hold harmless and defend TIPS, TIPS member(s), officers and employees, from and against all claims and suits for injuries (including death) to an officer, employee, agent, subcontractors, supplier or equipment lessee of the Vendor, arising out of, or resulting from, Vendor's work under this Agreement whether or not such claims are based in whole or in part upon the negligent acts or omissions of the TIPS, TIPS member(s), officers, employees, or agents.

Attorney's Fees--Texas Local Government Code § 271.159 is expressly referenced.

Pursuant to §271.159, TEXAS LOC. GOV'T CODE, in the event that any one of the Parties is required to obtain the services of an attorney to enforce this Agreement, the prevailing party, in addition to other remedies available, shall be entitled to recover reasonable attorney's fees and costs of court.

Multiple Vendor Awards

TIPS reserves the right to award multiple vendor Agreements for categories when deemed in the best interest of the TIPS membership. Bidders scoring the RFP's specified percentage or above will be considered for an award. Categories are established at the discretion of TIPS.

State of Texas Franchise Tax

By signature hereon, the bidder hereby certifies that he/she is not currently delinquent in the payment of any franchise taxes owed the State of Texas under Chapter 171, Tax Code.

Miscellaneous

The Vendor acknowledges and agrees that continued participation in TIPS is subject to TIPS sole discretion and that any Vendor may be removed from the participation in the Program at any time with or without cause. Nothing in the Agreement or in any other communication between TIPS and the Vendor may be construed as a guarantee that TIPS participants will submit any orders at any time. TIPS reserves the right to request additional proposals for items already on Agreement at any time.

Purchase Order Pricing/Product Deviation

If a deviation of pricing/product on a purchase order occurs, TIPS is to be notified within 48 hours of receipt of order.

Termination for Convenience

TIPS has the right to terminate the agreement for cause or no cause for convenience with a thirty-day written notice. Termination for convenience is required under 2 CFR part 200.

TIPS Member Purchasing Procedures

Purchase orders or their equal are issued by participating TIPS member to the awarded vendor indicating on the PO "Agreement Number". Order is emailed to TIPS at tipspo@tips-usa.com.

- Awarded vendor delivers goods/services directly to the participating member.
- Awarded vendor invoices the participating TIPS member directly.
- Awarded vendor receives payment directly from the participating member.
- Awarded vendor reports sales monthly to TIPS (unless prior arrangements have been made with TIPS to report monthly).

Form of Agreement

If a vendor submitting an offer requires TIPS and/or TIPS Member to sign an additional agreement, a copy of the proposed agreement must be included with the proposal. In response to submitted supplemental Vendor Agreement documents, TIPS will review proposed vendor Agreement documents. Vendor's Agreement document shall not become part of TIPS's Agreement with vendor unless and until an authorized representative of TIPS reviews and approves it.

Licenses

Awarded vendor shall maintain in current status all federal, state and local licenses, bonds and permits required for the operation of the business conducted by awarded vendor. Awarded vendor shall remain fully informed of and in compliance with all ordinances and regulations pertaining to the lawful provision of services under the Agreement. TIPS reserves the right to stop work and/or cancel Agreement of any awarded vendor whose license(s) expire, lapse, are suspended or terminated.

Novation

If awarded vendor sells or transfers all assets or the entire portion of the assets used to perform this Agreement, a successor in interest must guarantee to perform all obligations under this Agreement. TIPS reserves the right to accept or reject any new party. A simple change of name agreement will not change the Agreement obligations of awarded vendor.

Site Requirements (when applicable to service or job)

Cleanup: Awarded vendor shall clean up and remove all debris and rubbish resulting from their work as required or directed by TIPS Member. Upon completion of work, the premises shall be left in good repair and an orderly, neat, clean and unobstructed condition.

Preparation: Awarded vendor shall not begin a project for which TIPS Member has not prepared the site, unless awarded vendor does the preparation work at no cost, or until TIPS Member includes the cost of site preparation in a purchase order.

Site preparation includes, but is not limited to: moving furniture, installing wiring for networks or power, and similar pre-installation requirements.

Registered sex offender restrictions: For work to be performed at schools, awarded vendor agrees that no employee of a sub-contractor who has been adjudicated to be a registered sex offender will perform work at any time when students are or reasonably expected to be present.

Awarded vendor agrees that a violation of this condition shall be considered a material breach and may result in the cancellation of the purchase order at the TIPS Member's discretion.

Awarded vendor must identify any additional costs associated with compliance of this term. If no costs are specified, compliance with this term will be provided at no additional charge.

Safety measures: Awarded vendor shall take all reasonable precautions for the safety of employees on the worksite, and shall erect and properly maintain all necessary safeguards for protection of workers and the public. Awarded vendor shall post warning signs against all hazards created by the operation and work in progress. Proper precautions shall be taken pursuant to state law and standard practices to protect workers, general public and existing structures from injury or damage.

Smoking

Persons working under Agreement shall adhere to local smoking policies. Smoking will only be permitted in posted areas or off premises.

Invoices

The awarded vendor shall submit invoices to the participating entity clearly stating "Per TIPS Agreement". The shipment tracking number or pertinent information for verification shall be made available upon request.

Marketing

Awarded vendor agrees to allow TIPS to use their name and logo within website, marketing materials and advertisement. Any use of TIPS name and logo or any form of publicity, inclusive of press release, regarding this Agreement by awarded vendor must have prior approval from TIPS.

Supplemental agreements

The entity participating in the TIPS Agreement and awarded vendor may enter into a separate supplemental agreement to further define the level of service requirements over and above the minimum defined in this Agreement i.e. invoice requirements, ordering requirements, specialized delivery, etc. Any supplemental agreement developed as a result of this Agreement is exclusively between the participating entity and awarded vendor. TIPS, its agents, TIPS members and employees shall not be made party to any claim for breach of such agreement.

Survival Clause

All applicable software license agreements, warranties or service agreements that were entered into between Vendor and Customer under the terms and conditions of the Agreement shall survive the expiration or termination of the Agreement. All Purchase Orders issued and accepted by Order Fulfiller shall survive expiration or termination of the Agreement.

Legal obligations

It is the responding vendor's responsibility to be aware of and comply with all local, state and federal laws governing the sale of products/services identified in this RFP and any awarded Agreement thereof. Applicable laws and regulations must be followed even if not specifically identified herein.

Audit rights

Awarded Vendor shall, at their sole expense, maintain appropriate due diligence of all purchases made by TIPS Member that utilizes this Agreement. TIPS and Region 8 ESC each reserve the right to audit the accounting for a period of three (3) years from the time such purchases are made. This audit right shall survive termination of this Agreement for a period of one (1) year from the effective date of termination. TIPS shall have authority to conduct random audits of Awarded Vendor's pricing that is offered to TIPS Members. Notwithstanding the foregoing, in the event that TIPS is made aware of any pricing being offered to eligible entities that is materially inconsistent with the pricing under this agreement, TIPS shall have the ability to conduct the audit internally or may engage a third-party auditing firm. In the event of an audit, the requested materials shall be provided in the format and at the location designated by Region 8 ESC or TIPS.

Force Majeure

If by reason of Force Majeure, either party hereto shall be rendered unable wholly or in part to carry out its obligations under this Agreement then such party shall give notice and fully particulars of Force Majeure in writing to the other party within a reasonable time after occurrence of the event or cause relied upon, and the obligation of the party giving such notice, so far as it is affected by such Force Majeure, shall be suspended during the continuance of the inability then claimed, except as hereinafter provided, but for no longer period, and such party shall endeavor to remove or overcome such inability with all reasonable dispatch.

Services

When applicable, performance bonds and payment bonds will be required on construction or labor required jobs. Awarded vendor will meet the TIPS member's local and state purchasing requirements. Awarded vendors may need to provide additional capacity as jobs increase. Bonds will not require that a fee be paid to TIPS. The actual cost of the bond will be a pass through to the TIPS member and added to the purchase order or Agreement.

Scope of Services

The specific scope of work for each job shall be determined in advance and in writing between TIPS Member and Awarded vendor. It is okay if the TIPS member provides a general scope, but the awarded vendor should provide a written scope of work to the TIPS member as part of the proposal. Once the scope of the job is agreed to, the TIPS member will issue a PO and/or an Agreement with the estimate referenced as an attachment along with bond and any other special provisions agreed to for the TIPS member. If special terms and conditions other than those covered within this solicitation and awarded Agreements are required, they will be attached to the PO and shall take precedence over those in the base Agreement.

Project Delivery Order Procedures

The TIPS member having approved and signed an interlocal agreement, or other TIPS membership document, may make a request of the awarded vendor under this Agreement when the TIPS member has services that need to be undertaken. Notification may occur via phone, the web, email, fax, or in person.

Upon notification of a pending request, the awarded vendor shall make contact with the TIPS member as soon as possible, but must make contact with the TIPS member within two working days.

Scheduling of Projects

Scheduling of projects (if applicable) will be accomplished when the TIPS member issues a purchase order that will serve as "the notice to proceed". The period for the delivery order will include the mobilization, materials purchase, installation and delivery, design, weather, and site cleanup and inspection. No additional claims may be made for delays as a result of these items. When the tasks have been completed the awarded vendor shall notify the client and have the

TIPS member inspect the work for acceptance under the scope and terms in the PO. The TIPS member will issue in writing any corrective actions that are required. Upon completion of these items, the TIPS member will issue a completion notice and final payment will be issued.

Support Requirements

If there is a dispute between the awarded vendor and TIPS member, TIPS or its representatives will assist in conflict resolution or third party (mandatory mediation), if requested by either party. TIPS, or its representatives, reserves the right to inspect any project and audit the awarded vendors TIPS project files, documentation and correspondence.

Incorporation of Solicitation

The TIPS Request for Proposals or the Request for Competitive Sealed Proposals solicitation and all associated documents and forms made part of the solicitation process, including any addenda, that resulted in the execution of this agreement are hereby incorporated by reference into this agreement as if copied verbatim.

Special Terms and Conditions

It is the intent of TIPS to Agreement with a reliable, high performance vendor to supply products and services to government and educational agencies. It is the experience of TIPS that the following procedures provide TIPS, the Vendor, and the participating agency the necessary support to facilitate a mutually beneficial relationship. The specific procedures will be negotiated with the successful vendor.

- **Agreements:** All vendor purchase orders and/or Agreements/agreements must be emailed to TIPS at tipspo@tips-usa.com. Should an agency send an order direct to vendor, it is the vendor's responsibility to forward the order to TIPS at the email above within 24 business hours and confirm its receipt with TIPS.
 - **Promotion of Agreement:** It is agreed that Vendor will encourage all eligible entities to purchase from the TIPS Program. Encouraging entities to purchase directly from the Vendor and not through TIPS Agreement is a violation of the terms and conditions of this Agreement and will result in removal of the Vendor from the TIPS Program.
 - **Daily Order Confirmation:** All Agreement purchase orders will be approved daily by TIPS and sent to vendor. The vendor must confirm receipt of orders to the TIPS member (customer) within 24 business hours.
 - **Vendor custom website for TIPS:** If Vendor is hosting a custom TIPS website, then updated pricing must be posted by 1st of each month.
 - **Back Ordered Products:** If product is not expected to ship within 3 business days, customer is to be notified within 24 hours and appropriate action taken based on customer request.
-

Term of Agreement is one year with renewal options for up to two additional years as provided in the solicitation.

Page 12 of 12 will be the TIPS Vendor Agreement Signature Page

TIPS Vendor Agreement Signature Form

RFP 170302 Furniture, Furnishings and Services

Company Name ShuttleSystem, LLC

Address 4824 Socialville-Foster Rd

City Mason State OH Zip 45040

Phone 513-489-3727 Fax 513-489-7539

Email of Authorized Representative shuttle@ironfurnace.com

Name of Authorized Representative Jay L. Krause

Title National Contracts Manager

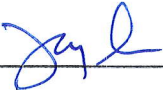
Signature of Authorized Representative 

Date 04/17/17

TIPS Authorized Representative Name Meredith Barton

Title Vice-President of Operations

TIPS Authorized Representative Signature 

Approved by ESC Region 8 

Date May 26, 2017

The Interlocal Purchasing System (TIPS Cooperative) Supplier Response

Bid Information		Contact Information		Ship to Information
Bid Creator	Rick Powell General Counsel/Procurement Compliance Officer	Address	Region 8 Education Service Center 4845 US Highway 271 North Pittsburg, TX 75686	Address
Email	rick.powell@tips-usa.com	Contact	Sarah Bond, Contracts Compliance Specialist	Contact
Phone	(903) 575-2689			Department
Fax				Building
Bid Number	170302 Addendum 1	Department		Floor/Room
Title	Furniture	Building		Telephone
Bid Type	RFP			Fax
Issue Date	3/2/2017 08:01 AM (CT)	Floor/Room		Email
Close Date	4/27/2017 03:00:00 PM (CT)	Telephone	+1 (866) 839-8477	
		Fax	+1 (866) 839-8472	
		Email	bids@tips-usa.com	

Supplier Information

Company Navetta (ShuttleSystem, LLC.)
 Address 4824 Socialville-Foster Road
 Suite 200
 Mason, OH 45040
 Contact
 Department
 Building
 Floor/Room
 Telephone (800) 411-1979
 Fax (513) 489-7539
 Email
 Submitted 4/27/2017 12:18:21 PM (CT)
 Total \$0.00

By submitting your response, you certify that you are authorized to represent and bind your company.

Signature Jay L. Krause

Email shuttle@ironfurnace.com

Supplier Notes

Bid Notes

Bid Activities

Bid Messages

Bid Attributes

Please review the following and respond where necessary

#	Name	Note	Response
1	Yes - No	Disadvantaged/Minority/Women Business Enterprise - D/M/WBE (Required by some participating governmental entities) Vendor certifies that their firm is a D/M/WBE? Vendor must upload proof of certification to the "Response Attachments" D/M/WBE CERTIFICATES section.	No
2	Yes - No	Highly Underutilized Business - HUB (Required by some participating governmental entities) Vendor certifies that their firm is a HUB? Vendor must upload proof of certification to the "Response Attachments" HUB CERTIFICATES section.	No
3	Yes - No	The Vendor can provide services and/or products to all 50 US States?	Yes
4	States Served:	If answer is NO to question #3, please list which states can be served. (Example: AR, OK, TX)	N/A
5	Company and/or Product Description:	This information will appear on the TIPS website in the company profile section, if awarded a TIPS contract. (Limit 750 characters.)	ShuttleSystem offers products for Educational Furniture solutions for all levels, for K-12 and higher education environments. Our innovative product system was developed in direct response to requests from educators around the country for a different type of furniture system. ShuttleSystem redefined "flexibility" and was designed to provide all the benefits of built in computer furniture with none of the disadvantages. The result was a product system that includes a latching mechanism that allows stations to be easily connected and disconnected and was based on a series of work surface shapes that are all interchangeable and inter connectable.
6	Primary Contact Name	Primary Contact Name	Tina Corder
7	Primary Contact Title	Primary Contact Title	Executive Sales Manager
8	Primary Contact Email	Primary Contact Email	tcorder@shuttlefurniture.com
9	Primary Contact Phone	Enter 10 digit phone number. (No dashes or extensions) Example: 8668398477	5134893727
10	Primary Contact Fax	Enter 10 digit phone number. (No dashes or extensions) Example: 8668398477	5134897539
11	Primary Contact Mobile	Enter 10 digit phone number. (No dashes or extensions) Example: 8668398477	N/A
12	Secondary Contact Name	Secondary Contact Name	Mandy Barnes
13	Secondary Contact Title	Secondary Contact Title	Accounting
14	Secondary Contact Email	Secondary Contact Email	mbarnes@shuttlefurniture.com

15	Secondary Contact Phone	Enter 10 digit phone number. (No dashes or extensions) Example: 8668398477	8004111979
16	Secondary Contact Fax	Enter 10 digit phone number. (No dashes or extensions) Example: 8668398477	5134897539
17	Secondary Contact Mobile	Enter 10 digit phone number. (No dashes or extensions) Example: 8668398477	n/a
18	Admin Fee Contact Name	Admin Fee Contact Name. This person is responsible for paying the admin fee to TIPS.	Jay L. Krause
19	Admin Fee Contact Email	Admin Fee Contact Email	shuttle@ironfurnace.com
20	Admin Fee Contact Phone	Enter 10 digit phone number. (No dashes or extensions) Example: 8668398477	8143427000
21	Purchase Order Contact Name	Purchase Order Contact Name. This person is responsible for receiving Purchase Orders from TIPS.	Tina Corder
22	Purchase Order Contact Email	Purchase Order Contact Email	tcorder@shuttlefurniture.com
23	Purchase Order Contact Phone	Enter 10 digit phone number. (No dashes or extensions) Example: 8668398477	5134893727
24	Company Website	Company Website (Format - www.company.com)	www.shuttlefurniture.com and www.navettadesign.com
25	Federal ID Number:	Federal ID Number also known as the Employer Identification Number. (Format - 12-3456789)	26-1573268
26	Primary Address	Primary Address	4824 Socialville-Foster Road Suite 200
27	Primary Address City	Primary Address City	Mason
28	Primary Address State	Primary Address State (2 Digit Abbreviation)	OH
29	Primary Address Zip	Primary Address Zip	45040
30	Search Words:	Please list search words to be posted in the TIPS database about your company that TIPS website users might search. Words may be product names, manufacturers, or other words associated with the category of award. YOU MAY NOT LIST NON-CATEGORY ITEMS. (Limit 500 words) (Format: product, paper, construction, manufacturer name, etc.)	Shuttle furniture, school furniture, teacher desk, teacher's desk, computer labs, computer tables, classroom furniture, mobile workstation, mobile storage, mobile desk, modular desk, furniture system, ergonomic desk, Shuttlemate, Shuttlezone, Shuttlesystem, cubbies, tandem, Techera, latchable return, storage cabinets, custom furniture, lecture room seating, swing out seating, lecture tables, lecture hall seating, auditorium seating, classroom seating, Navetta, Symmetra, Monolito, Pininfarina.
31	Yes - No	Do you wish to be eligible to participate in a TIPS contract in which a TIPS member utilizes federal funds on contracts exceeding \$100,000? (Non-Construction)	Yes
32	Yes - No	Certification of Residency (Required by the State of Texas) Company submitting bid is a Texas resident bidder?	No
33	Company Residence (City)	Vendor's principal place of business is in the city of?	Mason

34	Company Residence (State)	Vendor's principal place of business is in the state of?	OH
35	Felony Conviction Notice:	(Required by the State of Texas) My firm is, as outlined on PAGE 5 in the Instructions to Bidders document: (Questions 36 - 37)	(No Response Required)
36	Yes - No	A publicly held corporation; therefore, this reporting requirement is not applicable?	No
37	Yes - No	Is owned or operated by individual(s) who has/have been convicted of a felony?	No
38	Pricing Information:	Pricing information section. (Questions 39 - 42)	(No Response Required)
39	Yes - No	In addition to the typical unit pricing furnished herein, the Vendor agrees to furnish all current and future products at prices that are proportionate to Dealer Pricing. If answer is NO, include a statement detailing how pricing for TIPS participants would be calculated in the PRICING document that is uploaded to the "Response Attachments" PRICING section.	Yes
40	Yes - No	Pricing submitted includes the TIPS administration fee?	Yes
41	Yes - No	Vendor agrees to remit to TIPS the required administration fee?	Yes
42	Yes - No	Additional discounts to TIPS members for bulk quantities or scope of work?	No
43	Start Time	Average start time after receipt of customer order is ____ working days?	1
44	Years Experience	Company years experience in this category?	30
45	Resellers:	Does the vendor have resellers that it will name under this contract? (If applicable, vendor should download the Reseller/Dealers spreadsheet from the Attachments section, fill out the form and submit the document in the "Response Attachments" RESELLERS section.	Yes
46	Prices are guaranteed for?	(__ Month(s), __ Year(s), or Term of Contract) (Standard term is "Term of Contract")	Term of contract
47	Right of Refusal	Does the proposing vendor wish to reserve the right not to perform the awarded agreement with a TIPS member at your discretion?	No
48	NON-COLLUSIVE BIDDING CERTIFICATE	By submission of this bid or proposal, the Bidder certifies that: 1) This bid or proposal has been independently arrived at without collusion with any other Bidder or with any Competitor; 2) This bid or proposal has not been knowingly disclosed and will not be knowingly disclosed, prior to the opening of bids, or proposals for this project, to any other Bidder, Competitor or potential competitor; 3) No attempt has been or will be made to induce any other person, partnership or corporation to submit or not to submit a bid or proposal; 4) The person signing this bid or proposal certifies that he has fully informed himself regarding the accuracy of the statements contained in this certification, and under the penalties being applicable to the Bidder as well as to the person signing in its behalf. Not a negotiable term. Failure to agree will render your proposal non-responsive and it	(No Response Required)

will not be considered.

- 49 CONFLICT OF INTEREST QUESTIONNAIRE - FORM CIQ If you have a conflict of interest as described in this form or the Local Government Code Chapter 176, cited therein- you are required to complete and file with TIPS, Richard Powell, 4845 US Highway 271 North, Pittsburg, Texas 75686 No
- You may find the Blank CIQ form on our website at:
- Copy and Paste the following link into a new browser or tab:
<https://www.tips-usa.com/assets/documents/docs/CIQ.pdf>
- Do you have any conflicts under this statutory requirement?
- 50 Filing of Form CIQ If yes (above), have you filed a form CIQ as directed here?
- 51 Regulatory Standing I certify to TIPS for the proposal attached that my company is in good standing with all governmental agencies Federal or state that regulate any part of our business operations. If not, please explain in the next attribute question. Yes
- 52 Regulatory Standing Regulatory Standing explanation of no answer. N/A
- 53 Antitrust Certification Statements (Tex. Government Code § 2155.005) By submission of this bid or proposal, the Bidder certifies that:

I affirm under penalty of perjury of the laws of the State of Texas that:
(1) I am duly authorized to execute this contract on my own behalf or on behalf of the company, corporation, firm, partnership or individual (Company) listed below;
(2) In connection with this bid, neither I nor any representative of the Company has violated any provision of the Texas Free Enterprise and Antitrust Act, Tex. Bus. & Comm. Code Chapter 15;
(3) In connection with this bid, neither I nor any representative of the Company has violated any federal antitrust law;
(4) Neither I nor any representative of the Company has directly or indirectly communicated any of the contents of this bid to a competitor of the Company or any other company, corporation, firm, partnership or individual engaged in the same line of business as the Company. (No Response Required)

Instructions for Certification:

(No Response Required)

1. By agreeing to the form, the prospective lower tier participant is providing the certification set out on the form in accordance with these instructions.
2. The certification in this clause is a material representation of fact upon which reliance was placed when this transaction was entered into. If it is later determined that the prospective lower tier participant knowingly rendered an erroneous certification in addition to other remedies available to the federal government, the department or agency with which this transaction originated may pursue available remedies, including suspension and / or debarment.
3. The prospective lower tier participant shall provide immediate written notice to the person to which this proposal is submitted if at any time the prospective lower tier participant learns that its certification was erroneous when submitted or has become erroneous by reason of changed circumstances.
4. The terms "covered transaction," "debarred," "suspended," "ineligible," "lower tier covered transaction," "participants," "person," "primary covered transaction," "principal," "proposal" and "voluntarily excluded," as used in this clause, have the meanings set out in the Definitions and Coverage sections of rules implementing Executive Order 12549. You may contact the person to which this proposal is submitted for assistance in obtaining a copy of those regulations.
5. The prospective lower tier participant agrees by submitting this form that, should the proposed covered transaction be entered into, it shall not knowingly enter into any lower tier covered transaction with a person who is debarred, suspended, declared ineligible or voluntarily excluded from participation in this covered transaction, unless authorized by the department or agency with which this transaction originated.
6. The prospective lower tier participant further agrees by submitting this form that it will include this clause titled "Certification Regarding Debarment, Suspension, Ineligibility and Voluntary Exclusion-Lower Tier Covered Transaction" without modification in all lower tier covered transactions and in all solicitations for lower tier covered transactions.
7. A participant in a covered transaction may rely upon a certification of a prospective participant in a lower tier covered transaction that it is not debarred, suspended, ineligible or voluntarily excluded from the covered transaction, unless it knows that the certification is erroneous. A participant may decide the method and frequency by which it determines the eligibility of its principals. Each participant may, but is not required to, check the Nonprocurement List.
8. Nothing contained in the foregoing shall be construed to require establishment of a system of records in order to render in good faith the certification required by this clause. The knowledge and information of a participant is not required to exceed that which is normally possessed by a prudent person in the ordinary course of business dealings.
9. Except for transactions authorized under paragraph 5 of these instructions, if a participant in a covered transaction knowingly enters into a lower tier covered transaction with a person who is suspended, debarred, ineligible or voluntarily excluded from participation in this transaction, in addition to other remedies available to the federal government, the department or agency with which this transaction originated may pursue available remedies,

including suspension and / or debarment.

- 55 Suspension or Debarment Certification Debarment and Suspension (Executive Orders 12549 and 12689)—A contract award (see 2 CFR 180.220) must not be made to parties listed on the governmentwide exclusions in the System for Award Management (SAM), in accordance with the OMB guidelines at 2 CFR 180 that implement Executive Orders 12549 (3 CFR part 1986 Comp., p. 189) and 12689 (3 CFR part 1989 Comp., p. 235), "Debarment and Suspension." SAM Exclusions contains the names of parties debarred, suspended, or otherwise excluded by agencies, as well as parties declared ineligible under statutory or regulatory authority other than Executive Order 12549. Yes

By submitting this offer and certifying this section, this bidder:
Certifies that no suspension or disbarment is in place, which would preclude receiving a federally funded contract as described above.

- 56 Non-Discrimination Statement and Certification In accordance with Federal civil rights law and U.S. Department of Agriculture (USDA) civil rights regulations and policies, the USDA, its Agencies, offices, and employees, and institutions participating in or administering USDA programs are prohibited from discriminating based on race, color, national origin, religion, sex, gender identity (including gender expression), sexual orientation, disability, age, marital status, family/parental status, income derived from a public assistance program, political beliefs, or reprisal or retaliation for prior civil rights activity, in any program or activity conducted or funded by USDA (not all bases apply to all programs). Remedies and complaint filing deadlines vary by program or incident. Yes

Persons with disabilities who require alternative means of communication for program information (e.g., Braille, large print, audiotope, American Sign Language, etc.) should contact the responsible Agency or USDA's TARGET Center at (202) 720-2600 (voice and TTY) or contact USDA through the Federal Relay Service at (800) 877-8339. Additionally, program information may be made available in languages other than English.
To file a program discrimination complaint, complete the USDA Program Discrimination Complaint Form, AD-3027, found online at How to File a Program Discrimination Complaint and at any USDA office or write a letter addressed to USDA and provide in the letter all of the information requested in the form. To request a copy of the complaint form, call (866) 632-9992. Submit your completed form or letter to USDA by: (1) mail: U.S. Department of Agriculture, Office of the Assistant Secretary for Civil Rights, 1400 Independence Avenue, SW, Washington, D.C. 20250-9410; (2) fax: (202) 690-7442; or (3) email: program.intake@usda.gov.
(Title VI of the Education Amendments of 1972; Section 504 of the Rehabilitation Act of 1973; the Age Discrimination Act of 1975; Title 7 CFR Parts 15, 15a, and 15b; the Americans with Disabilities Act; and FNS Instruction 113-1, Civil Rights Compliance and Enforcement – Nutrition Programs and Activities)
USDA is an equal opportunity provider, employer, and lender.

Not a negotiable term. Failure to agree will render your proposal non-responsive and it will not be considered. I

certify that in the performance of a contract with TIPS or its members, that our company will conform to the foregoing anti-discrimination statement and comply with the cited law and regulations.

- 57 2 CFR PART 200 Contract Provisions Explanation (No Response Required)
- Required Federal contract provisions of Federal Regulations for Contracts for contracts with ESC Region 8 and TIPS Members:
- The following provisions are required to be in place and agreed if the procurement is funded in any part with federal funds.
- The ESC Region 8 and TIPS Members is the subgrantee or Subrecipient by definition. The federal Rule numbering or identification below is only for reference purpose on this form and does not identify an actual Federal designation or location of the rule. The Rules are located in 2 CFR PART 200 - Appendix II to Part 200—Contract Provisions for Non-Federal Entity Contracts Under Federal Awards at 2 CFR PART 200.
- In addition to other provisions required by the Federal agency or non-Federal entity, all contracts made by the non-Federal entity under the Federal award must contain provisions covering the following, as applicable.
- 58 2 CFR PART 200 (A) Contracts Yes
- Contracts for more than the simplified acquisition threshold currently set at \$150,000, which is the inflation adjusted amount determined by the Civilian Agency Acquisition Council and the Defense Acquisition Regulations Council (Councils) as authorized by 41 U.S.C. 1908, must address administrative, contractual, or legal remedies in instances where contractors violate or breach contract terms, and provide for such sanctions and penalties as appropriate. Notice: Pursuant to Federal Rule (A) above, when federal funds are expended by ESC Region 8 and TIPS Members, ESC Region 8 and TIPS Members reserves all rights and privileges under the applicable laws and regulations with respect to this procurement in the event of breach of contract by either party.
- Does vendor agree?
- 59 2 CFR PART 200 (B) Termination Yes
- Termination for cause and for convenience by the grantee or subgrantee including the manner by which it will be effected and the basis for settlement. (All contracts in excess of \$10,000)
- Pursuant to Federal Rule (B) above, when federal funds are expended by ESC Region 8 and TIPS Members, ESC Region 8 and TIPS Members reserves the right to terminate any agreement in excess of \$10,000 resulting from this procurement process for cause after giving the vendor an appropriate opportunity and up to 30 days, to cure the causal breach of terms and conditions. ESC Region 8 and TIPS Members reserves the right to terminate any agreement in excess of \$10,000 resulting from this procurement process for convenience with 30 days notice in writing to the awarded vendor. The vendor would be compensated for work performed and goods procured as of the termination date if for convenience of the ESC Region 8 and TIPS Members. Any award under this procurement process is not exclusive and the ESC Region 8 and TIPS reserves the right to purchase goods and services from other vendors when it is in the best interest of the ESC Region 8 and TIPS.
- Does vendor agree?

60	2 CFR PART 200 (G) Clean Air Act	<p>Clean Air Act (42 U.S.C. 7401-7671q.) and the Federal Water Pollution Control Act (33 U.S.C. 1251-1387), as amended—Contracts and subgrants of amounts in excess of \$150,000 must contain a provision that requires the non-Federal award to agree to comply with all applicable standards, orders or regulations issued pursuant to the Clean Air Act (42 U.S.C. 7401-7671q) and the Federal Water Pollution Control Act as amended (33 U.S.C. 1251-1387). Violations must be reported to the Federal awarding agency and the Regional Office of the Environmental Protection Agency (EPA).</p> <p>Pursuant to Federal Rule (G) above, when federal funds are expended by ESC Region 8 and TIPS Members, ESC Region 8 and TIPS Members requires that the proposer certify that during the term of an award by the ESC Region 8 and TIPS Members resulting from this procurement process the vendor agrees to the terms listed and referenced therein.</p> <p>Does vendor agree?</p>	Yes
61	2 CFR PART 200 (H) Debarment and Suspension	<p>Debarment and Suspension (Executive Orders 12549 and 12689)—A contract award (see 2 CFR 180.220) must not be made to parties listed on the governmentwide exclusions in the System for Award Management (SAM), in accordance with the OMB guidelines at 2 CFR 180 that implement Executive Orders 12549 (3 CFR part 1986 Comp., p. 189) and 12689 (3 CFR part 1989 Comp., p. 235), "Debarment and Suspension." SAM Exclusions contains the names of parties debarred, suspended, or otherwise excluded by agencies, as well as parties declared ineligible under statutory or regulatory authority other than Executive Order 12549.</p> <p>Pursuant to Federal Rule (H) above, when federal funds are expended by ESC Region 8 and TIPS Members, ESC Region 8 and TIPS Members requires the proposer certify that during the term of an award by the ESC Region 8 and TIPS Members resulting for this procurement process the vendor certifies that they are not debarred from receiving a contract from the federal government as provided therein.</p> <p>Does vendor agree?</p>	Yes
62	2 CFR PART 200 (I) Byrd Anti-Lobbying Amendment	<p>Byrd Anti-Lobbying Amendment (31 U.S.C. 1352)—Contractors that apply or bid for an award exceeding \$100,000 must file the required certification. Each tier certifies to the tier above that it will not and has not used Federal appropriated funds to pay any person or organization for influencing or attempting to influence an officer or employee of any agency, a member of Congress, officer or employee of Congress, or an employee of a member of Congress in connection with obtaining any Federal contract, grant or any other award covered by 31 U.S.C. 1352. Each tier must also disclose any lobbying with non-Federal funds that takes place in connection with obtaining any Federal award. Such disclosures are forwarded from tier to tier up to the non-Federal award.</p> <p>Pursuant to Federal Rule (I) above, when federal funds are expended by ESC Region 8 and TIPS Members, ESC Region 8 and TIPS Members requires the proposer certify that during the term and after the awarded term of an award by the ESC Region 8 and TIPS Members resulting for this procurement process the vendor certifies to the terms included or referenced therein.</p> <p>Does vendor agree?</p>	Yes

- | | | | |
|----|---------------------------------------------------|------------------------------------------------------------------------------------------------------------------------------------------------------------------------------------------------------------------------------------------------------------------------------------------------------------------------------------------------------------------------------------------------------------------------------------------------------------------------------------------------------------------------------------------------------------------------------------------------------------------------------------------------------------------------------------------------------------------------------------------------------------------------------------------------------------------------------------------------------------------------------------------------------------------------------------------------------------------------------------------------------------------------------------------------------------|-----|
| 63 | 2 CFR PART 200 Federal Rule (12) | <p>Federal Rule (12) Compliance with all applicable standards, orders, or requirements issued under section 306 of the Clean Air Act (42 U.S.C. 1857(h)), section 508 of the Clean Water Act (33 U.S.C. 1368), Executive Order 11738, and Environmental Protection Agency regulations (40 CFR part 15). (Contracts, subcontracts, and subgrants of amounts in excess of \$100,000)</p> <p>Pursuant to Federal Rule (12) above, when federal funds are expended by ESC Region 8 and TIPS Members, ESC Region 8 and TIPS Members requires the proposer certify that in performance of the contracts, subcontracts, and subgrants of amounts in excess of \$100,000, the vendor will be in compliance with all applicable standards, orders, or requirements issued under section 306 of the Clean Air Act (42 U.S.C. 1857(h)), section 508 of the Clean Water Act (33 U.S.C. 1368), Executive Order 11738, and Environmental Protection Agency regulations (40 CFR part 15).</p> <p>Does vendor certify that it is in compliance with the Clean Air Act?</p> | Yes |
| 64 | 2 CFR PART 200 Procurement of Recovered Materials | <p>A non-Federal entity that is a state agency or agency of a political subdivision of a state and its contractors must comply with section 6002 of the Solid Waste Disposal Act, as amended by the Resource Conservation and Recovery Act. The requirements of Section 6002 include procuring only items designated in guidelines of the Environmental Protection Agency (EPA) at 40 CFR part 247 that contain the highest percentage of recovered materials practicable, consistent with</p> <p>maintaining a satisfactory level of competition, where the purchase price of the item exceeds \$10,000 or the value of the quantity acquired during the preceding fiscal year exceeded \$10,000; procuring solid waste management services in a manner that maximizes energy and resource recovery; and establishing an affirmative procurement program for procurement of recovered materials identified in the EPA guidelines.</p> <p>Does vendor certify that it is in compliance with the Solid Waste Disposal Act as described above?</p> | Yes |

65 Indemnification

The ESC Region 8 and TIPS is a Texas Political Subdivision and a local governmental entity; therefore, is prohibited from indemnifying third parties pursuant to the Texas Constitution (Article 3, Section 52) except as specifically provided by law or as ordered by a court of competent jurisdiction. A provision in a contract to indemnify or hold a party harmless is a promise to pay for any expenses the indemnified party incurs, if a specified event occurs, such as breaching the terms of the contract or negligently performing duties under the contract. Article III, Section 49 of the Texas Constitution states that "no debt shall be created by or on behalf of the State ... " The Attorney General has counseled that a contractually imposed obligation of indemnity creates a "debt" in the constitutional sense. Tex. Att'y Gen. Op. No. MW-475 (1982). Contract clauses which require the System or institutions to indemnify must be deleted or qualified with "to the extent permitted by the Constitution and Laws of the State of Texas." Liquidated damages, attorney's fees, waiver of vendor's liability, and waiver of statutes of limitations clauses should also be deleted or qualified with "to the extent permitted by the Constitution and laws of State of Texas." Not a negotiable term. Failure to agree will render your proposal non-responsive and it will not be considered. Do you agree to these terms?

Yes

66 Remedies

The parties shall be entitled to exercise any right or remedy available to it either at law or in equity, subject to the choice of law, venue and service of process clauses limitations agreed herein. Nothing in this agreement shall commit the TIPS to an arbitration resolution of any disagreement under any circumstances. Any Claim arising out of or related to the Contract, except for those specifically waived under the terms of the Contract, may, after denial of the Board of Directors, be subject to mediation at the request of either party. Any issues not resolved hereunder must be referred to non-binding mediation to be conducted by a mutually agreed upon mediator as a prerequisite to the filing of any lawsuit over such issue(s). The parties shall share the mediator's fee and any associated filing fee equally. Mediation shall be held in Camp or Titus County, Texas. Agreements reached in mediation shall be reduced to writing, and will be subject to the approval by the District's Board of Directors, signed by the Parties if approved by the Board of Directors, and, if signed, shall thereafter be enforceable as provided by the laws of the State of Texas. Do you agree to these terms?

Yes, I Agree

67 Remedies Explanation of No Answer

N/a

68	Choice of Law	<p>This agreement and any addenda or other additions and all contracts or awards resulting from this procurement process, however described, shall be governed by, construed and enforced in accordance with the laws of the State of Texas, regardless of any conflict of laws principles.</p> <p>Not a negotiable term. Failure to agree will render your proposal non-responsive and it will not be considered. Do you agree to these terms?</p>	Yes
69	Jurisdiction and Service of Process	<p>Any Proceeding arising out of or relating to this procurement process or any contract issued by TIPS resulting from or any contemplated transaction shall be brought in a court of competent jurisdiction in Camp County, Texas and each of the parties irrevocably submits to the exclusive jurisdiction of said court in any such proceeding, waives any objection it may now or hereafter have to venue or to convenience of forum, agrees that all claims in respect of the Proceeding shall be heard and determined only in any such court, and agrees not to bring any proceeding arising out of or relating to this procurement process or any contract resulting from or any contemplated transaction in any other court. The parties agree that either or both of them may file a copy of this paragraph with any court as written evidence of the knowing, voluntary and freely bargained for agreement between the parties irrevocably to waive any objections to venue or to convenience of forum. Process in any Proceeding referred to in the first sentence of this Section may be served on any party anywhere in the world. Venue clauses in contracts with TIPS members may be determined by the parties.</p> <p>Not a negotiable term. Failure to agree will render your proposal non-responsive and it will not be considered. Do you agree to these terms?</p>	Yes
70	Alternative Dispute Resolution	<p>Prior to filing of litigation, the parties may select non-binding mediation as a method of conflict resolution for issues arising out of or relating to this procurement process or any contract resulting from or any contemplated transaction. The parties agree that if nonbinding mediation is chosen as a resolution process, the parties must agree to the chosen mediator(s) and that all mediation venue shall be at a location in Camp or Titus, County, Texas agreed by the parties. The parties agree to share equally the cost of the mediation process and venue cost.</p> <p>Do you agree to these terms?</p>	Yes, I Agree
71	Alternative Dispute Resolution Explanation of No Answer		n/a
72	Infringement(s)	<p>The successful vendor will be expected to indemnify and hold harmless the TIPS and its employees, officers, agents, representatives, contractors, assignees and designees from any and all third party claims and judgments involving infringement of patent, copyright, trade secrets, trade or service marks, and any other intellectual or intangible property rights in connection with the vendor's proposal or ultimate contracts awarded and approved.</p>	Yes, I Agree

Do you agree to these terms?

73	Infringement(s) Explanation of No Answer		n/a
74	Acts or Omissions	The successful vendor will be expected to indemnify and hold harmless the TIPS, its officers, employees, agents, representatives, contractors, assignees and designees from and against any and all liability, actions, claims, demands or suits, and all related costs, attorney's fees and expenses arising out of, or resulting from any acts or omissions of the vendor or its agents, employees, subcontractors, or suppliers in the execution or performance of any agreements ultimately made by TIPS and the vendor. Do you agree to these terms?	Yes, I Agree
75	Acts or Omissions Explanation of No Answer		n/a
76	Contract Governance	Any contract made or entered into by the TIPS is subject to and is to be governed by Section 271.151 et seq, Tex Loc Gov't Code. Otherwise, TIPS does not waive its governmental immunities from suit or liability except to the extent expressly waived by other applicable laws in clear and unambiguous language.	Yes
77	Payment Terms and Funding Out Clause	Payment Terms: TIPS members pay net 30 or at point of sale and complies with the State of Texas payment law, Texas Government Code, Chapter 2251. See statute for specifics or consult your legal counsel. These are minimum terms required of the TIPS member in Texas by law and the parties may negotiate custom payment terms as desired provided they do not violate the statutory requirements. Statutory or binding regulations control TIPS members in this contract. Funding out Clause: Pursuant to Texas Local Government Code Sec. 271.903, any proposal offer accepted by TIPS and its members and all contracts to be approved are subject to the budgeting and appropriation of then currently available funds. See statute for specifics or consult your legal counsel. Not a negotiable term. Failure to agree will render your proposal non-responsive and it will not be considered. Do you agree to these terms?	Yes

78 Insurance and Fingerprint Requirements Information

Insurance

If applicable and your staff will be on TIPS member premises for delivery, training or installation etc. and/or with an automobile, you must carry automobile insurance as required by law. You may be asked to provide proof of insurance.

Fingerprint

It is possible that a vendor may be subject to Chapter 22 of the Texas Education Code. The Texas Education Code, Chapter 22, Section 22.0834. Statutory language may be found at: <http://www.statutes.legis.state.tx.us/>

If the vendor has staff that meet both of these criterion:
(1) will have continuing duties related to the contracted services; and

(2) has or will have direct contact with students

Then you have "covered" employees for purposes of completing the attached form.

TIPS recommends all vendors consult their legal counsel for guidance in compliance with this law. If you have questions on how to comply, see below. If you have questions on compliance with this code section, contact the Texas Department of Public Safety Non-Criminal Justice Unit, Access and Dissemination Bureau, FAST-FACT at

NCJU@txdps.state.tx.us and you should send an email identifying you as a contractor to a Texas Independent School District or ESC Region 8 and TIPS. Texas DPS phone number is (512) 424-2474.

See form in the next attribute to complete entitled:

Texas Education Code Chapter 22 Contractor Certification for Contractor Employees

(No Response Required)

79 Texas Education Code Chapter 22 Contractor Certification for Contractor Employees

Introduction: Texas Education Code Chapter 22 requires entities that contract with school districts to provide services to obtain criminal history record information regarding covered employees. Contractors must certify to the district that they have complied. Covered employees with disqualifying criminal histories are prohibited from serving at a school district.

Definitions: Covered employees: Employees of a contractor or subcontractor who have or will have continuing duties related to the service to be performed at the District and have or will have direct contact with students. The District will be the final arbiter of what constitutes direct contact with students. Disqualifying criminal history: Any conviction or other criminal history information designated by the District, or one of the following offenses, if at the time of the offense, the victim was under 18 or enrolled in a public school:

(a) a felony offense under Title 5, Texas Penal Code; (b) an offense for which a defendant is required to register as a sex offender under Chapter 62, Texas Code of Criminal Procedure; or (c) an equivalent offense under federal law or the laws of another state.

I certify that:

NONE (Section A) of the employees of Contractor and any subcontractors are covered employees, as defined above. If this box is checked, I further certify that Contractor has taken precautions or imposed conditions to ensure that the employees of Contractor and any subcontractor will not become covered employees. Contractor will maintain these precautions or conditions throughout the time the contracted services are provided.

OR

SOME (Section B) or all of the employees of Contractor and any subcontractor are covered employees. If this box is checked, I further certify that:

(1) Contractor has obtained all required criminal history record information regarding its covered employees. None of the covered employees has a disqualifying criminal history.

(2) If Contractor receives information that a covered employee subsequently has a reported criminal history, Contractor will immediately remove the covered employee from contract duties and notify the District in writing within 3 business days.

(3) Upon request, Contractor will provide the District with the name and any other requested information of covered employees so that the District may obtain criminal history record information on the covered employees.

(4) If the District objects to the assignment of a covered employee on the basis of the covered employee's criminal history record information, Contractor agrees to discontinue using that covered employee to provide services at the District.

Noncompliance or misrepresentation regarding this certification may be grounds for contract termination.

80 Solicitation Deviation/Compliance

Does the vendor agree with the General Conditions Standard Terms and Conditions or Item Specifications listed in this proposal invitation? Yes

81 Solicitation Exceptions/Deviations Explanation	<p>If the bidder intends to deviate from the General Conditions Standard Terms and Conditions or Item Specifications listed in this proposal invitation, all such deviations must be listed on this attribute, with complete and detailed conditions and information included or attached.</p> <p>TIPS will consider any deviations in its proposal award decisions, and TIPS reserves the right to accept or reject any bid based upon any deviations indicated below or in any attachments or inclusions.</p> <p>In the absence of any deviation entry on this attribute, the proposer assures TIPS of their full compliance with the Standard Terms and Conditions, Item Specifications, and all other information contained in this Solicitation.</p>	n/a
82 Agreement Deviation/Compliance	Does the vendor agree with the language in the Vendor Agreement?	Yes
83 Agreement Exceptions/Deviations Explanation	<p>If the proposing Vendor desires to deviate from the Vendor Agreement language, all such deviations must be listed on this attribute, with complete and detailed conditions and information included. TIPS will consider any deviations in its proposal award decisions, and TIPS reserves the right to accept or reject any proposal based upon any deviations indicated below. In the absence of any deviation entry on this attribute, the proposer assures TIPS of their full compliance with the Vendor Agreement.</p>	n/a

Line Items

Response Total: \$0.00



TIPS – The Interlocal Purchasing System

Region 8 Education Service Center | 4845 US Hwy 271 North | Pittsburg, Texas 75686

Date: May 26, 2017

RE: 170302 – Furniture (Addendum 1)

Addendum 1 was issued 4/7/2017. This addendum added a separate upload section for the price lists required for this RFP. There were no other addendums issued for this RFP. This original bid closing date was extended from April 21, 2017 to April 27, 2017.

Sarah Bond

Sarah Bond
Contracts Compliance Specialist

Screen shot from TIPS eBid System, showing the history of RFP 170302 – Furniture (Addendum 1)

Bid Audit History		
Return		
Date	Line	Description
5/1/2017 09:07 AM (CT)	Header	Bid request unsealed by SBOND TIPS.
4/27/2017 03:00 PM (CT)	Header	Bid request closed by the system.
4/11/2017 01:10 PM (CT)	Header	Bid Close Date extended from 4/21/2017 03:00:00 PM (CT) to 4/27/2017 03:00:00 PM (CT). By RPOWELLTIPS. Reason: To provide more time for vendors to respond.
4/7/2017 11:50 AM (CT)	Header	Addendum issued by the system.
4/7/2017 11:50 AM (CT)	Header	Addendum published by RPOWELLTIPS. Reason: TIPS added an upload section for the Pricing Spreadsheet #2. Both pricing spreadsheets are required
4/7/2017 11:40 AM (CT)	Header	Bid Request Information Copied from Bid '170302' by RPOWELLTIPS.
3/2/2017 08:01 AM (CT)	Header	Bid request issued by the system.
2/28/2017 09:29 AM (CT)	Header	Bid request published by RPOWELLTIPS. - Issue time adjusted by the system to balance workload.
2/27/2017 10:06 AM (CT)	Header	Bid Request Information Copied from Bid '444444' by RPOWELLTIPS.
2/27/2017 10:06 AM (CT)	Header	Bid Request created by RPOWELLTIPS.
Items 1-10 shown of 10		
Addendum Audit History		
Return		
Date	Line	Description
4/7/2017 11:40 AM (CT)	Header	Addendum 1 created for bid '170302' by RPOWELLTIPS.
Items 1-1 shown of 1		

REFERENCES

Please provide three (3) references, preferably from school districts or other governmental entities who have used your services within the last three years. Additional references may be required. DO NOT INCLUDE TIPS EMPLOYEES AS A REFERENCE.

You may provide more than three (3) references.

Entity Name	Contact Person	Email	Phone
Brandies Universities	Deepa Venkat	dvenkat@eypae.com	617.305.9857
Brandies Universities	Drew Strong	strongsales@comcast.net	413.267.0001
University of Texas - Arlington	Jeff Johnson	jjohnson@uta.edu	817.272.3232
UC Kowalweski	Brandon Okel	bokel@unicon.cc	513-482-2700
UC Kowalweski	Michael Maltinsky	mmaltinsky@glaserworks.com	513-665-9555

Resellers - Dealers

Reseller/Dealer Name	Address	City	State	Zip	Contact Name	Contact Email	Contact Phone	Contact Fax	Company Website
Library Furniture International	1945 Techny Rd. Unit 10	Northbrook	IL	60062	Meghann Replin	meghann@libraryfurniture-intl.com	847-564-9497	847-564-9337	www.libraryfurniture-intl.com
Red Thread	22 Boston Wharf Rd	Boston	MA	02210-1101	Mary Sauvageau	msauvageau@red-thread.com	860-291-5780	860-528-1843	www.red-thread.com
School & Office Products	2323 Cantrell Rd.	Little Rock	AR	72202	Terry Greene	itgreene7437@sbcglobal.net	501-663-5500	501-663-5508	http://sopainc.com/
Rutter & Associates	4125 White Hawk Lane	Winston Salem	NC	27106	Harrison rutter	Harrison@harrisonrutter.com	336-760-8651		www.harrisonrutter.com

Certification Regarding Lobbying

Applicable to Grants, Subgrants, Cooperative Agreements, and Contracts Exceeding \$100,000 in Federal Funds.

Submission of this certification is a prerequisite for making or entering into this transaction and is imposed by section 1352, Title 31, U.S. Code. This certification is a material representation of fact upon which reliance was placed when this transaction was made or entered into. Any person who fails to file the required certification shall be subject to a civil penalty of not less than \$10,000 and not more than \$100,000 for each such failure.

The undersigned certifies, to the best of his or her knowledge and belief, that:

(1) No Federal appropriated funds have been paid or will be paid by or on behalf of the undersigned, to any person for influencing or attempting to influence an officer or employee of any agency, a Member of Congress, an officer or employee of congress, or an employee of a Member of Congress in connection with the awarding of a Federal contract, the making of a Federal grant, the making of a Federal loan, the entering into a cooperative agreement, and the extension, continuation, renewal, amendment, or modification of a Federal contract, grant, loan, or cooperative agreement.

(2) If any funds other than Federal appropriated funds have been paid or will be paid to any person for influencing or attempting to influence an officer or employee of any agency, a Member of Congress, an officer or employee of congress, or an employee of a Member of Congress in connection with this Federal grant or cooperative agreement, the undersigned shall complete and submit Standard Form-LLL, "disclosure Form to Report Lobbying," in accordance with its instructions.

(3) The undersigned shall require that the language of this certification be included in the award documents for all covered subawards exceeding \$100,000 in Federal funds at all appropriate tiers and that all subrecipients shall certify and disclose accordingly.

ShuttleSystem, 4824 Socialville-Foster Rd., Suite 200, Mason, OH 45040

Name/Address of Organization

Jay L. Krause, National Contracts Manager

Name/Title of Submitting Official



Signature

04/17/2017

Date

FELONY CONVICTION NOTICE

Statutory citation covering notification of criminal history of contractor is found in the Texas Education Code #44.034. Following is an example of a felony conviction notice:

State of Texas Legislative Senate Bill No. 1, Section 44.034, Notification of Criminal History, Subsection (a), states "a person or business entity that enters into a contract with a school district or ESC 8/TIPS must give advance notice to the district or ESC 8/TIPS if the person or an owner or operator of the business entity has been convicted of a felony. The notice must include a general description of the conduct resulting in the conviction of a felony."

Subsection (b) states "a school district may terminate a contract with a person or business entity if the district determines that the person or business entity failed to give notice as required by Subsection (a) or misrepresented the conduct resulting in the conviction. The district must compensate the person or business entity for services performed before the termination of the contract."

THIS NOTICE IS NOT REQUIRED OF A PUBLICLY-HELD CORPORATION

Complete only one of the three below: A or B or C.

I, the undersigned agent for the firm named below, certify that the information concerning notification of felony convictions has been reviewed by me and the following information furnished is true to the best of my knowledge.

Official: Jay L. Krause
Print Authorized Company Official's Name

A. My firm is a publicly held corporation; therefore, this reporting requirement is not applicable.

Signature of Authorized Company Official: _____

B. My firm is not owned nor operated by anyone who has been convicted of a felony:

Signature of Authorized Company Official: Jay L. Krause

C. My firm is owned or operated by the following individual(s) who has/have been convicted of a felony:

Name of Felon(s): _____

Details of Conviction(s): _____

Signature of Authorized Company Official: _____



Jay L. Krause, National Contracts Manager

4824 Socialville-Foster Road
Mason, Ohio 45040
800-411-1979

CORPORATE RESOLUTION

RESOLVED, that it is desirable and in the best interest of this corporation that it participate in state, national, and federal procurement opportunities, and that Jay L. Krause serve as its National Contracts Manager to this end, and further resolved that as such, Jay L. Krause is hereby authorized to perform on behalf of this corporation any and all such acts as deemed necessary or advisable in order to comply with the applicable laws of any state, and in connection therewith to execute and file all requisite papers and documents, including, but not limited to, applications and reports.

ATTEST, that the undersigned hereby certifies that the foregoing is a true and correct copy of a corporate resolution duly adopted on Monday, March 14, 2016; and that said resolution is in full force and effect.

A handwritten signature in blue ink, appearing to read "Gregg Lund", written over a horizontal line.

Gregg Lund, CEO



Jay L. Krause, National Contracts Manager

4824 Socialville-Foster Road
Mason, Ohio 45040
800-411-1979

CORPORATE RESOLUTION

RESOLVED, that it is desirable and in the best interest of this corporation that it participate in state, national, and federal procurement opportunities, and that Jay L. Krause serve as its National Contracts Manager to this end, and further resolved that as such, Jay L. Krause is hereby authorized to perform on behalf of this corporation any and all such acts as deemed necessary or advisable in order to comply with the applicable laws of any state, and in connection therewith to execute and file all requisite papers and documents, including, but not limited to, applications and reports.

ATTEST, that the undersigned hereby certifies that the foregoing is a true and correct copy of a corporate resolution duly adopted on Monday, March 14, 2016; and that said resolution is in full force and effect.

A handwritten signature in blue ink, appearing to read 'Gregg Lund', is written over a horizontal line. The signature is stylized and includes a large loop.

Gregg Lund, CEO

Federal Requirements for Procurement and Contracting with small and minority businesses, women's business enterprises, and labor surplus area firms.

The Education Service Center Region 8 and TIPS anticipate possibly using federal funds for procurement under this potential award and is required to obtain the following compliance assurance.

1. Will you be subcontracting any of your work under this award if you are successful? (Circle one)

YES or NO

2. If yes, do you agree to comply with the following federal requirements? (Circle one)

YES or NO

2 CFR §200.321 Contracting with small and minority businesses, women's business enterprises, and labor surplus area firms.

(a) The non-Federal entity must take all necessary affirmative steps to assure that minority businesses, women's business enterprises, and labor surplus area firms are used when possible.

(b) Affirmative steps must include:

(1) Placing qualified small and minority businesses and women's business enterprises on solicitation lists;

(2) Assuring that small and minority businesses, and women's business enterprises are solicited whenever they are potential sources;

(3) Dividing total requirements, when economically feasible, into smaller tasks or quantities to permit maximum participation by small and minority businesses, and women's business enterprises;

(4) Establishing delivery schedules, where the requirement permits, which encourage participation by small and minority businesses, and women's business enterprises;

(5) Using the services and assistance, as appropriate, of such organizations as the Small Business Administration and the Minority Business Development Agency of the Department of Commerce ; and

(6) Requiring the prime contractor, if subcontracts are to be let, to take the affirmative steps listed in paragraphs (1) through (5) of this section.

Company Name ShuttleSystem, LLC dba Navetta

Print name of authorized representative Jay L. Krause

Signature of authorized representative



Date 04/20/17

FAILURE TO PROPERLY COMPLETE THIS FORM AND SUBMIT WITH YOUR RESPONSE MAY RESULT IN A WAIVER OF YOUR RIGHTS UNDER THE LAW TO MAINTAIN CONFIDENTIALITY TREATMENT OF SUBMITTED MATERIALS.

CONFIDENTIAL INFORMATION SUBMITTED IN RESPONSE TO COMPETITIVE PROCUREMENT REQUESTS OF EDUCATION SERVICE CENTER REGION 8 AND TIPS IS GOVERNED BY TEXAS GOVERNMENT CODE, CHAPTER 552

If you consider any portion of your proposal to be confidential information and not subject to public disclosure pursuant to Chapter 552 Tex Gov't Code or other law(s), you **must make a copy of all claimed confidential materials within your proposal and put this COMPLETED form as a cover sheet to said materials then scan, name "CONFIDENTIAL" and upload with your proposal submission.** (You must include the confidential information in the submitted proposal as well, the copy uploaded is to indicate which material in your proposal, if any, you deem confidential in the event the District receives a Public Information Request.) Education Service Center Region 8 and TIPS will follow procedures of controlling statute(s) regarding any claim of confidentiality and shall not be liable for any release of information required by law. Pricing of solicited product or service may be deemed as public information under Chapter 552 Tex Gov't Code. The Office of Texas Attorney General shall make the final determination whether the information held by Education Service Center Region 8 and TIPS is confidential and exempt from public disclosure.

I DO NOT desire to expressly waive any claim of confidentiality as to any and all information contained within our response to the competitive procurement process (e.g. RFP, CSP, Bid, RFQ, etc.) by completing the following and submitting this sheet with our response to Education Service Center Region 8 and TIPS. The attached contains material from our proposal that I classify and deem confidential under Texas Gov't Code Sec. 552 or other law(s) and I invoke my statutory rights to confidential treatment of the enclosed materials:

Name of company claiming confidential status of material

Printed Name, Title, and Signature of authorized company officer claiming confidential status of material

Address City State ZIP Phone

ATTACHED ARE COPIES OF _____ PAGES OF CONFIDENTIAL MATERIAL FROM OUR PROPOSAL

Express Waiver: I desire to expressly waive any claim of confidentiality as to any and all information contained within our response to the competitive procurement process (e.g. RFP, CSP, Bid, RFQ, etc.) by completing the following and submitting this sheet with our response to Education Service Center Region 8 and TIPS.

ShuttleSystem, LLC

Name of company expressly waiving confidential status of material

Jay L. Krause, National Contracts Manager

Printed Name, Title, and Signature of authorized company officer expressly waiving confidential status of material

4824 socialville-Foster Rd. Mason OH 45040 513-489-7539

Address City State ZIP Phone



Jay L. Krause, National Contracts Manager

4824 Socialville-Foster Road
Mason, Ohio 45040
800-411-1979

Limited Warranty

All products are guaranteed against defective material and workmanship for a period of fifteen (15) years from the date of actual receipt by the user, except optional gas strut mechanisms guaranteed for 5 years. This warranty does not apply to any product which has been altered or modified from the original design or specification, or to any product damage resulting from accidents, negligence, or shipping.

1-800-411-1979

www.shuttlefurniture.com

NAVETTA WARRANTY

Warranty for specified Navetta Lecture Room Products: Symmetra • Symmetra Plus • Omnia • Monolito

Navetta provides the following warranty to the original purchaser of the above listed Navetta products sold in North America and installed by Navetta-approved installers. This warranty begins on the date of product invoice, is governed by and subject to the terms and conditions detailed below, and is non-transferable.

Navetta warrants its products to be substantially free from material defects in materials and craftsmanship. Defects found during normal usage of the product will be covered during the warranty period set out below, provided that written notification of the alleged defect is given to Navetta at the address below prior to expiration of the applicable period. Navetta will at its sole discretion either repair or replace the product it determines to be defective with a comparable product. All other costs are excluded.

The fulfillment of the warranty is under the control of Navetta. In the event Navetta fails to repair or replace a product it has determined is defective as provided herein, the purchaser's sole remedy shall be the return of the purchase price actually paid by purchaser for the defective product on a prorated basis based upon a useful life of ten (10) years.

Warranty Period

Within ten (10) years of initial shipment: Fixed structural components.

Within five (5) years of initial shipment: All other structural components, including seat support arms and pivot mechanisms, springs, tablet arms.

Within three (3) years of initial shipment: Plastic components and paint finishes, wood, laminate and other surface finishes (note conditions as to color, grain, and texture set forth below).

Within one (1) year of initial shipment: Power and electrical components, seating upholstery including foam (note restrictions as to color, grain, and texture below).

Exclusions and Conditions

This warranty excludes and does not apply to:

Conditions other than normal wear and tear.

Abuse, neglect, vandalism, or misuse.

In-transit damage.

Products altered or modified by the purchaser.

Products installed on flooring that does not meet structural standards.

Purchaser supplied or specified material, leather, and non-standard material and color finishes (whether purchased by the purchaser or Navetta).

Natural variations occurring in wood and leather and/or color fastness and/or variations in matching of colors, grains or textures of materials.

Product color change due to natural aging, UV exposure, cleaning solutions, or other causes.

Disclaimer of all Other Warranties

There are no other warranties than those expressly stated above, whether expressed or implied (including, but not limited to any warranty of merchantability or fitness for any particular purpose). Navetta is not liable for consequential or incidental damage arising from any product defect.

Limitation of Liability

Navetta's total liability hereunder shall not exceed the purchase price paid for the allegedly defective product. In no event shall Navetta be liable for any indirect, consequential, incidental or special damages, including lost profits, loss of reputation, loss of goodwill, lost revenue, or any other economic or non economic loss.

Warranty Notice Address

Navetta division of Shuttlesystem
11340 Montgomery Road, Suite 205
Cincinnati OH 45249
513-489-3727

SYMMETRA SERIES

An elegant new environment for learning



Navetta™

SYMMETRA

Elegant and durable—modern design at the intersection of form and function.



DESIGNED FOR LEARNING

The Symmetra™ fixed table system provides a unique, integrated environment for learning. The clean and modern design even extends to the under-table raceway system. Symmetra is a confident blend of form and function that will complement any advanced learning environment.

PRACTICAL AESTHETIC

Symmetra stands on ultra-rigid steel pedestals, and each installation is individually designed to fit perfectly with the size and appearance of your facility.



SYMMETRA PLUS

The ultimate lecture room solution integrated seating



INTEGRATED SEATING SYSTEM

Symmetra Plus™ adds the convenience of swing out seating to your facility. Choose from several comfortable and sturdy seat types, with or without upholstery.

DESIGNED FOR YOU

The Symmetra and Symmetra Plus fixed table systems can be as simple or as comprehensive as you like. Start with a basic table design, and choose materials, trim options, and colors. You can add integrated power and data systems, swing-out seats, special end panels and modesty panels, and more.

INNER BEAUTY

Precision engineering provides innovative functionality and durability

CONNECTIVITY SOLUTIONS

Under-table or top-mounted access to integrated modular Power/Data system.

INTERLOCKING DESIGN

Modesty panel interlocks into tabletop surface for extra rigidity.

PERFECT-FIT SUPPORT SYSTEM

Precision laser-cut structural steel brackets adjust for exact fit in any installation, then lock in place.

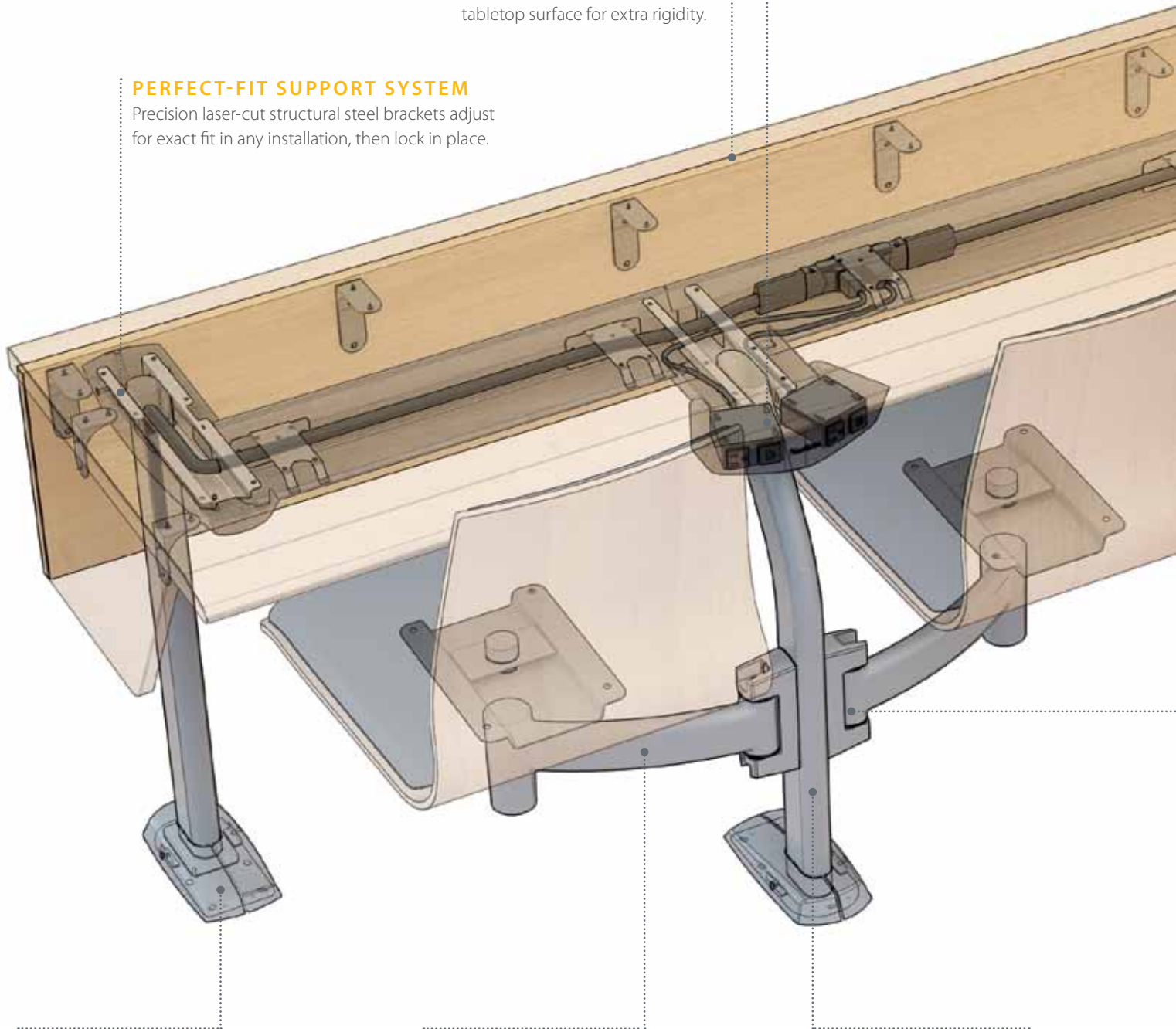

POWER-ENTRY PEDESTAL

Provides convenient access to power and data connections during installation.

CURVED SEAT SUPPORT ARM

Unique design provides increased legroom and elegant appearance.

ARC-DESIGN PEDESTAL

A single length of rugged oval steel tubing is precision-formed to eliminate sharp corners and the possibility of welding imperfections.

SECURE WIRE MANAGEMENT

All power and data connections and wiring are concealed beneath a secure integrated raceway system.

CAD-BASED PRECISION

Each component is factory-engineered and manufactured with precisely located pre-drilled holes for a perfect fit.

COMPREHENSIVE SEAT OPTIONS

Symmetra Plus can be supplied with a wide variety of premium seat styles and designs, with or without upholstery.

ABUSE-PROOF FOOT COVERS

Ultra-rugged toughened nylon foot covers are virtually unbreakable— and designed for the most demanding environments.

SPRING-RETURN SWINGARM

Rugged swingarm design with internal torsion spring provides full access, then returns to flush position when not in use.

SILENT-ROTATION SEAT BASE

Seat support cylinders provide full rotation and automatically align with table when not occupied. Adjustable height cylinders also available.

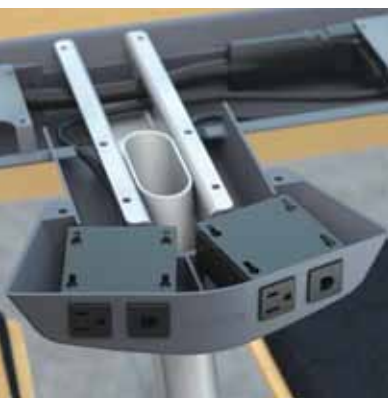

LEADING EDGE

Providing the ultimate designs for learning

CLEAN DESIGN, OPEN MINDS

Too often, architectural products compromise form over function—or vice versa. At Navetta, we treat the art and science of product design in a very different way. Our team of engineers and designers has collaborated to create modern, functional educational furniture with clean lines, smart design, and superior engineering. As a result, our fixed seating systems are as elegant as they are durable.

INFINITE POSSIBILITIES

Transform and customize your facility with our Symmetra fixed table system. Each installation is specially designed to meet your exact requirements—from single classrooms to oversized lecture halls; with flat, sloped, or tiered floors; in straight or curved rows; with or without integrated seating.

MAY WE HELP YOU?

Our collaborative design process continues as we work with you, from design through installation. Whatever your vision for your learning environments, we will work with you to bring that vision to life. Contact us today to start the conversation.



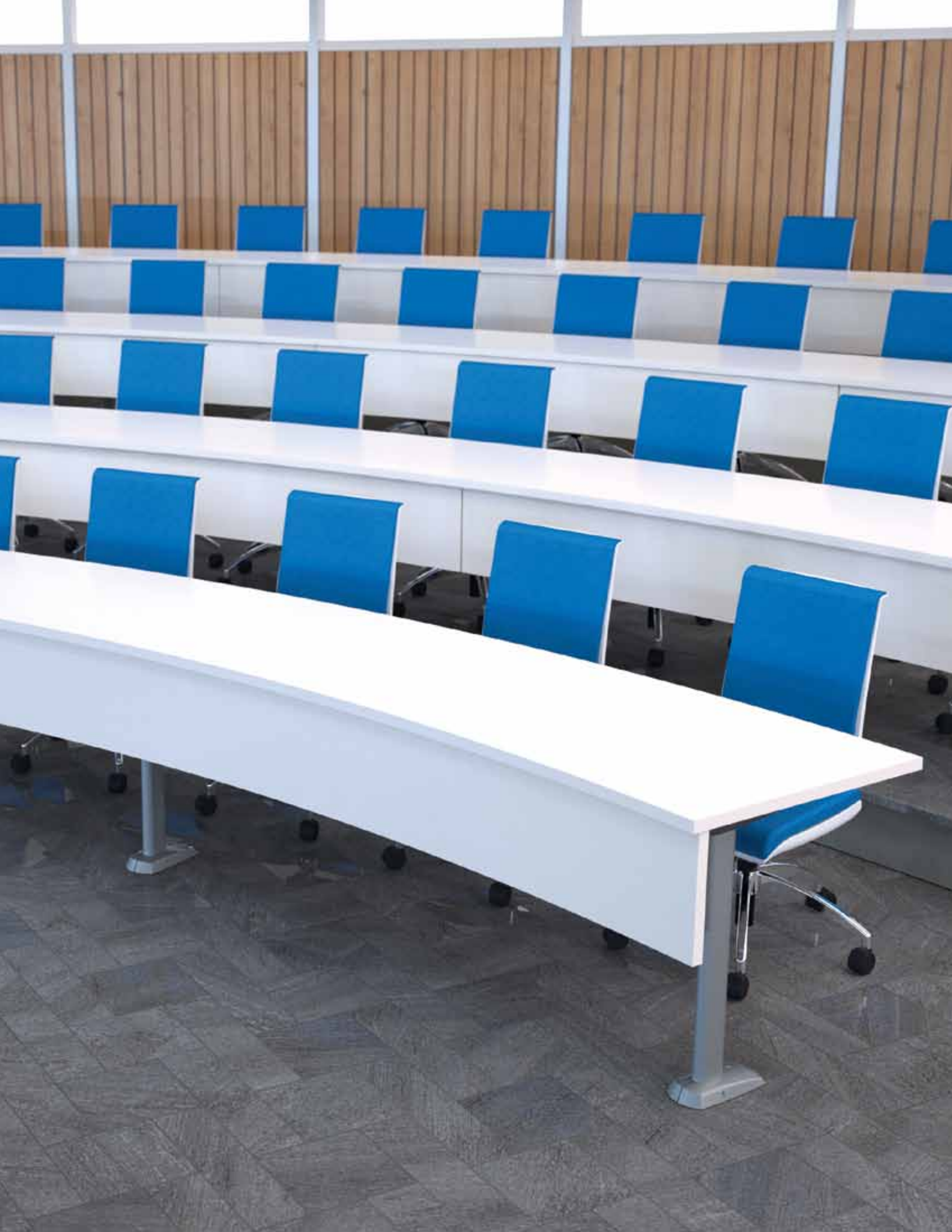



MONOLITO
Commanding presence

MONOLITO

Commanding presence



A SINGLE UNIFIED POWERFUL FORCE

Handsome and imposing in its simplicity, Monolito provides a dignified environment for lecture halls, meeting rooms, auditoriums, or wherever learning happens. Start with Monolito's superior engineering and classic lines, select the option that best suits your space and needs, and then customize it with our extraordinary color and finish options.

AN ORGANIZED WHOLE

Connectivity is clean and easy with Monolito's under-table or top-mounted access to an integrated modular power and data system. For secure wire management, all connections and wiring are concealed beneath a secure integrated raceway system.





ENDLESS VARIATIONS

Both the modesty panel and the table leg's decorative center panel are available in different finishes, including Ecoresin panels in stunning translucent colors.

ELEGANT FUNCTIONALITY

Interlocking components make for perfect fit, support, and rigidity. The sleek anodized aluminum finish handles wear and tear. An open design provides easy access and is ADA friendly.



OMNIA SPACESAVER

Innovative design allows for more seats in a given space

Design: Giovanni Baccolini

Navetta™

OMNIA SPACESAVER

Innovative design allows for more seats in a given space



STRAIGHT OR CURVED ROWS

Whether you choose the flip-top or fixed work surface for your installation, the design can accommodate either straight or curved rows.

FLAT, SLOPED, OR TIERED FLOORS

Each Omnia system is designed and built specifically for your installation. The system can accommodate flat, sloped, or tiered floors. There's also a high-back Omnia Evolution system for steeply tiered facilities.



FLIP-TOP OR FIXED-TOP



SPACE-SAVINGS SOLUTIONS

The Omnia Spacesaver system is a powerful tool for designing new facilities or retrofitting existing ones. The innovative Spacesaver design can fit the maximum number of seats in virtually any space.

FLIP-UP DESKTOP

The desktop is designed with a unique “anti-panic” feature. When the user stands, the seat folds against the seat back, and the desktop flips upward and out of the way, automatically clearing the aisle for exit.

OMNIA BEAM

Streamlined appearance and simple install



BEAM-MOUNTED SEATING SYSTEM

For straight row installations, the Omnia Beam provides all the features and functionality of the Omnia system, supported by a central beam and rugged pedestals. For many facilities, this design provides a streamlined appearance and can simplify installation because the number of fixing points to the floor is notably reduced.

CUSTOMIZED FOR EVERY INSTALLATION

Whatever your vision, each Omnia system can be tailored specifically to your needs. We can help you achieve your goals.

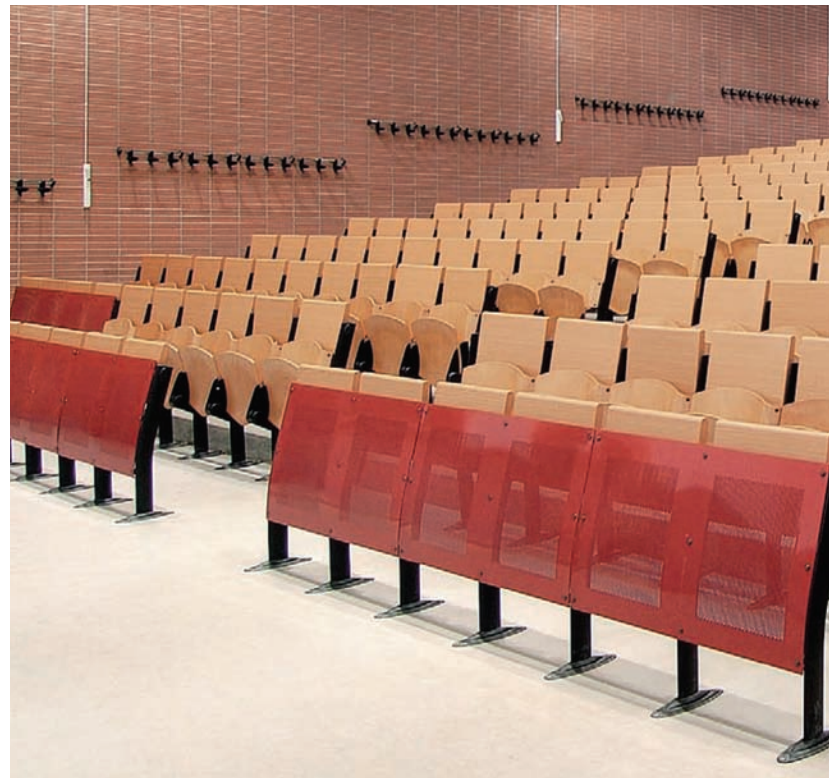

FLIP-TOP OR FIXED-TOP



OMNIA CONTRACT

Beam seating system with integrated flip-up tablets



INTEGRATED SEATING SYSTEM

The Omnia Contract system carries forward the philosophy of the Omnia series: it inherits the design of the backrest and the comfort of the seat. It offers an ideal and precise solution to every need.

FLEXIBLE OPTIONS

As well as the fixed version on four legs and the swivel version on casters, Omnia Contract offers a full range of seating on beam, with fixed or tip-up seat, with or without armrests, with anti-panic writing table or with a courtesy side table.

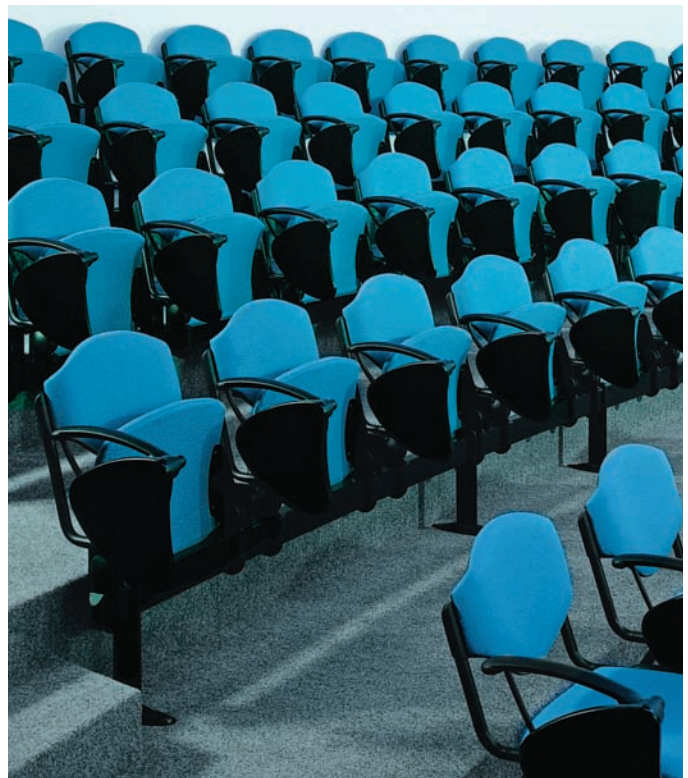

OMNIA SERIES DIMENSIONS

Flip-up writing top

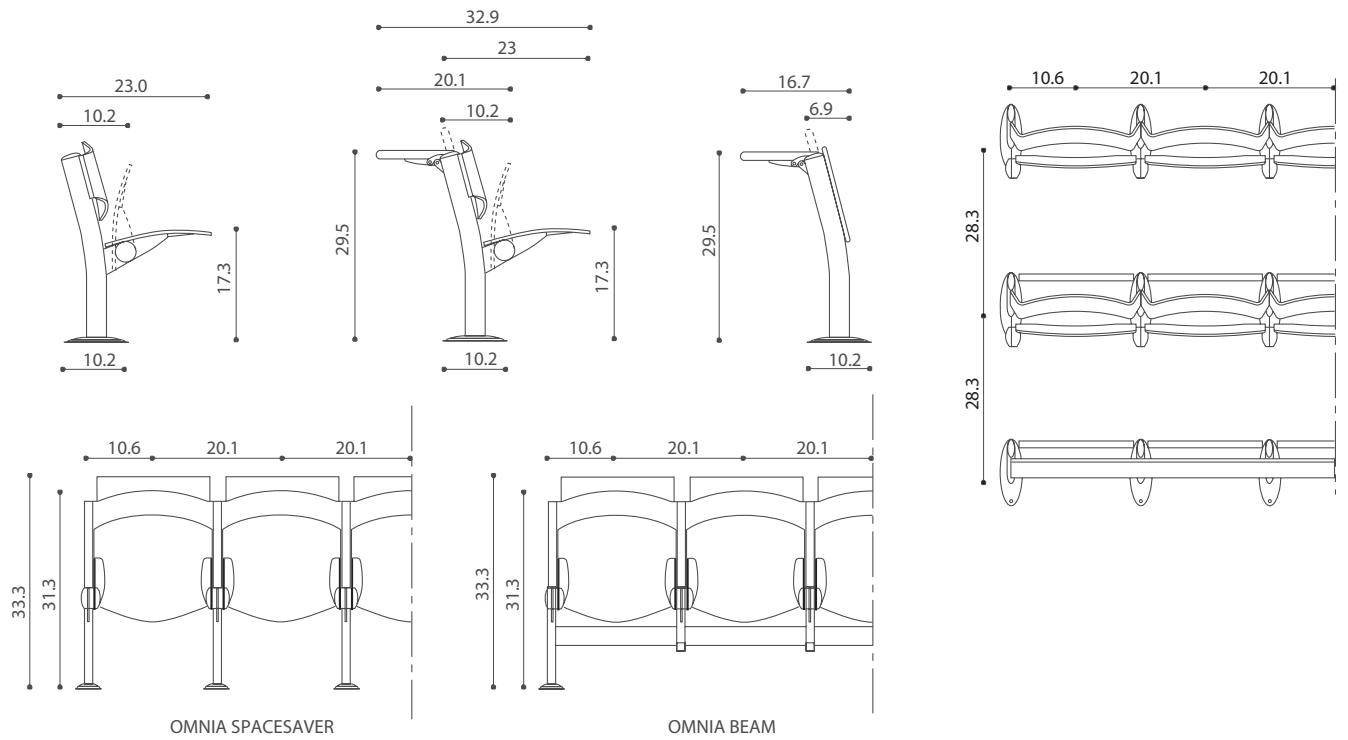

Fixed writing top

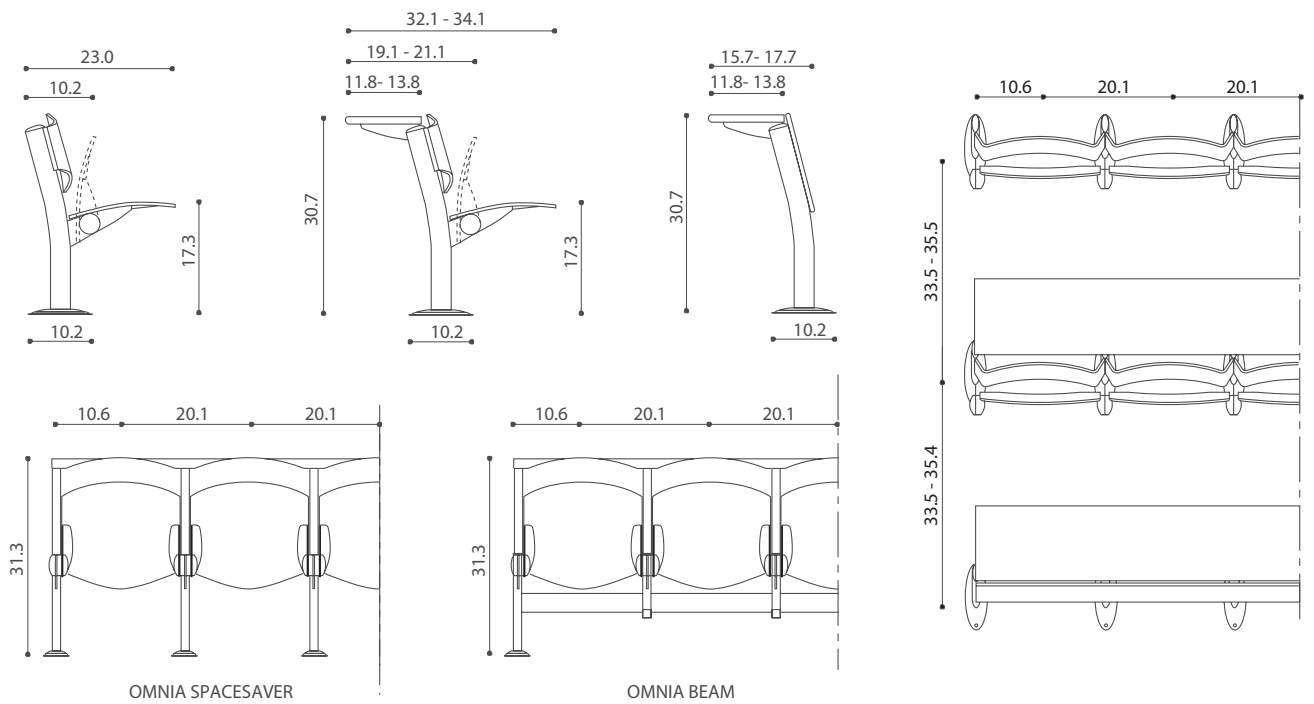

OMNIA EVOLUTION

The first high-back space-saving seating solution for steeply tiered floors



Design: Giovanni Baccolini

Navetta™

OMNIA EVOLUTION

The first high-back space-saving seating solution for steeply tiered floors

NEW FOR 2012

A winning product line should never be changed, but it can be re-styled. Omnia Spacesaver seating is now suitable for even the most sophisticated intellectual settings.

Omnia Evolution's modularity permits a limitless range of seating possibilities, including perforated seats to improve acoustics, seatbacks with headrest/frontal panel, anti-panic writing tablets for curved rows, and frontal panels featuring closely-spaced strips of sound-absorbing material.



TRILOGY

Casual simplicity



Design: Sandrin

Navetta™

TRILOGY

Available with swing out base, task base, or four-leg base

CASUAL SIMPLICITY

The Trilogy collection of multipurpose chairs offers clean design and superior quality at an excellent value. Versatile and adaptable, the Trilogy series fits effortlessly in offices, meeting and waiting areas, or training rooms.

Available with swing-out, task, or four-leg base or as a bar-mounted unit, the chairs come in white, grey, and black polypropylene with the option of upholstered seat and seat back.

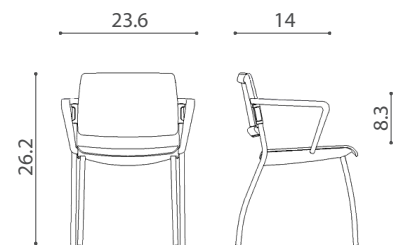
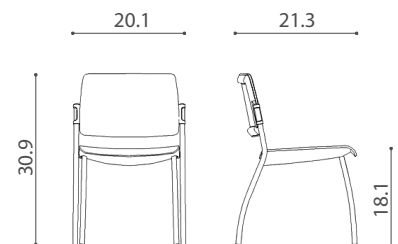
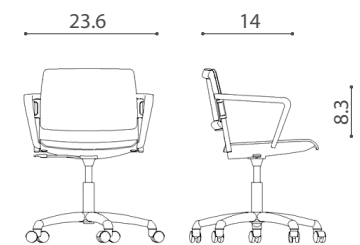
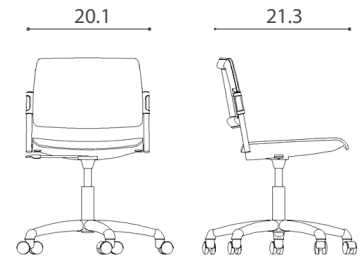

SMART
Essential elegance



Design: Studio Ares

Navetta™

SMART

Available with swing out base, task base, or four-leg base

ESSENTIAL ELEGANCE

A linear shape and up-to-the-minute colors make Smart the ideal seating for personalizing functional spaces that need to convey a strong personality. The base and the armrests in polished chrome-plated finish fully express Smart's essential elegance.

SPECIFICATIONS

The seat is made of birch plywood while the back is made of reinforced polypropylene. The padding is made of polyurethane foams with differentiated densities. The shells for covering the backrest and the seat are made of black or gray shockproof and scratchproof polypropylene. The fixed armrests are made of black or gray injection-molded nylon reinforced with glass fiber. The adjustable armrests have a black varnished or chrome-plated steel frame and black polypropylene coverings. The five-star base can be either in black or gray nylon reinforced with glass fiber, in black painted aluminum, or in chrome-plated steel. The fixed bases are in tubular steel, painted either black or gray or chrome-plated.

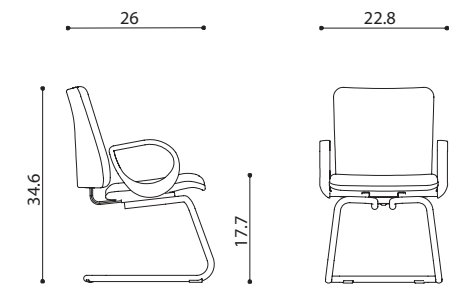
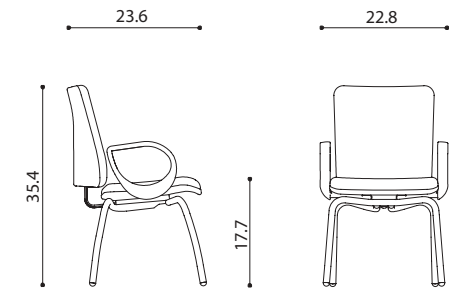
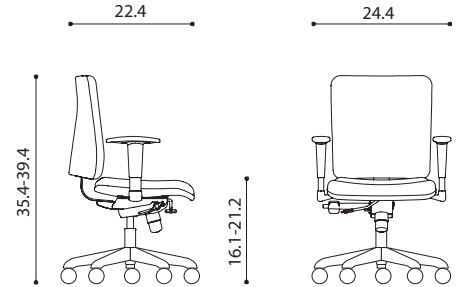

FLOU

Elegant Simplicity



Navetta™

FLOU

Available with swing out base, task base, or four-leg base

ELEGANT SIMPLICITY

Available in wood, plastic, and upholstered versions, the soft lines make Flou perfect for large and small rooms. Thanks to a whole range of accessories and different versions, the Flou series can cover every functional and organizational need. The chairs and executive chairs in the series are fully stackable, even with armrests and tablets, and are equipped with numerous accessories making them perfect for use in many different rooms. The chairs are linkable, making them ideal for creating seating groups in auditoriums or conference rooms. Also suitable for use in these rooms is the fixed-seat or tip-up bench, up to 5 seats on the same cross beam. With the addition of upholstery, Flou provides even more possibilities to furnish big and small rooms.

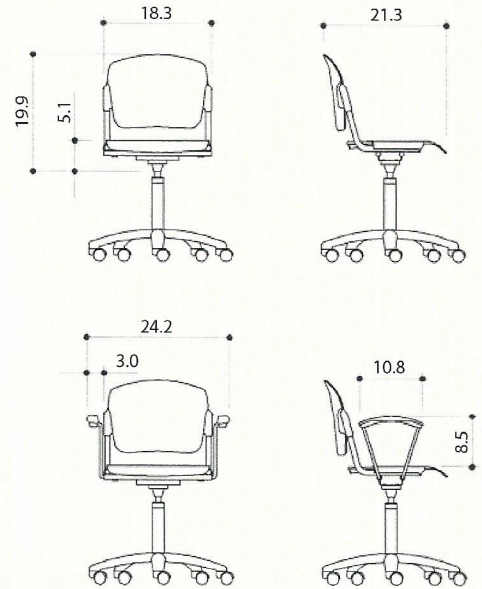

Navetta[™]
PLEASE BE SEATED

800.411.1979 / www.NavettaDesign.com

© 2013 Navetta/Shuttlesystem—0113-5k

ZERO 7

Operative multi-functionality



Design: Giovanni Baccolini

Navetta[™]

ZERO 7

Available with swing out base, task base, or four-leg base

OPERATIVE MULTI-FUNCTIONALITY

Zero7 is a new chair that combines all the important aspects of contemporary seating. It is offered in a multitude of versions: with or without headrest, padded, with mesh or plastic backrests, with fixed or multi-adjustable armrests, and with a swivel base or a fixed leg base.

SPECIFICATIONS

The backrest is made of black, gray, or white polypropylene with lumbar support in ABS, covered with soft black polyurethane. The optional upholstered back panel and headrest and its lumbar support are polypropylene. The back mesh is made with a black nylon frame, coated with black, gray, or white nylon mesh. The lumbar support is made of black polyethylene. The seat is polypropylene reinforced with steel square tubular bars; the seat cover is made of black, gray, or white shockproof polypropylene. The fixed armrests are made of black, gray, or white polypropylene. The adjustable armrests are chrome-plated steel with black polypropylene. The fixed four-leg base is in either black-painted or chrome-plated tubular steel.

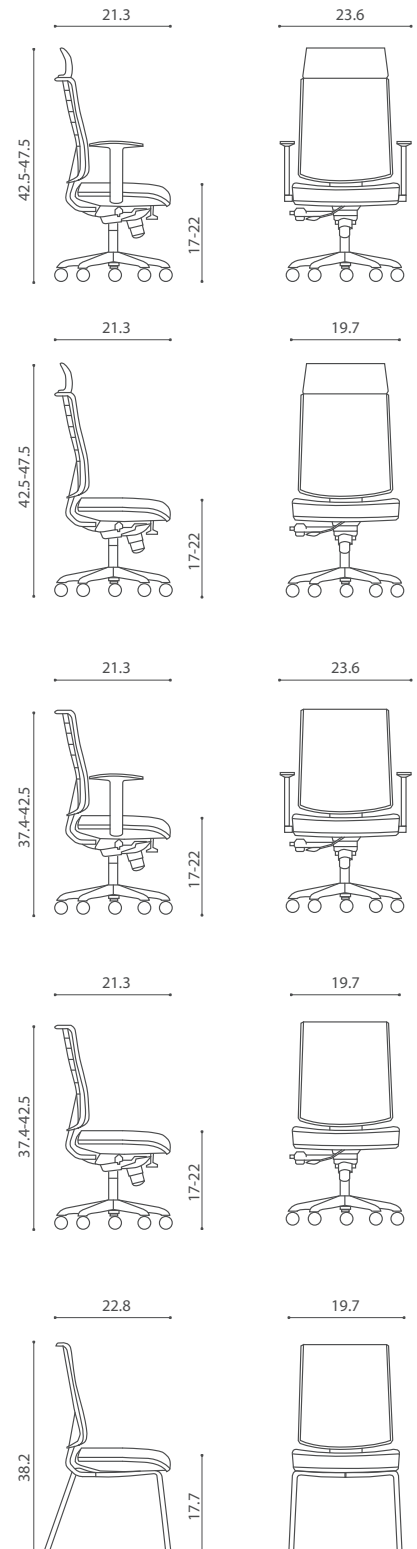

ZERO 9
Comfort and versatility



Design: Giovanni Baccolini

Navetta™

ZERO 9

Waiting Seat

COMFORT AND VERSATILITY

The Zero 9 is a multipurpose chair designed for office, lecture hall and training rooms. Special attention was given to the development of the compound curvature back to ensure many hours of comfort and support. It has excellent stacking and nesting capabilities. The same frame can be equipped with casters, glides or a casters+glides combination.

SPECIFICATIONS

The flip-up and flexible backrest are available in many finishes and colors to include scratch-proof PP with an optional upholstered panel padded with fire-retardant polyurethane foam or beech ply-wood and engineered wood veneer. Two wire steel springs enable the flexing back movement. The back supports are made of polished die-cast aluminum. The frame is made of ellipsoidal section tubular steel, including a nylon easy-ganging device for conference use. All metal parts are epoxy powder coated grey or white with matching PP components of the structure. The flip-up arms are polypropylene reinforced with glass-fiber. The removable anti-panic writing tablet is fixed on a polished die-cast aluminum support, available for right or left handed user. The tablet is made of heavy-duty HPL (High Pressure Laminate) with an eased-edge and is available in a grey aluminium color.

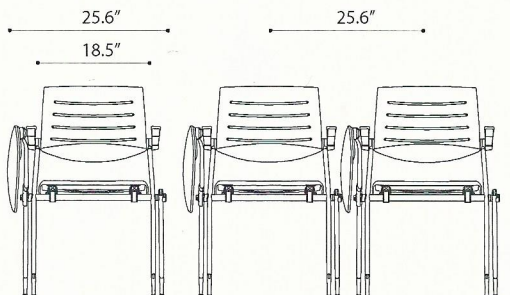
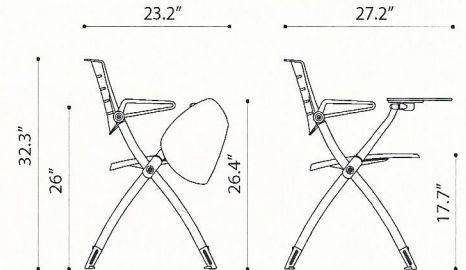
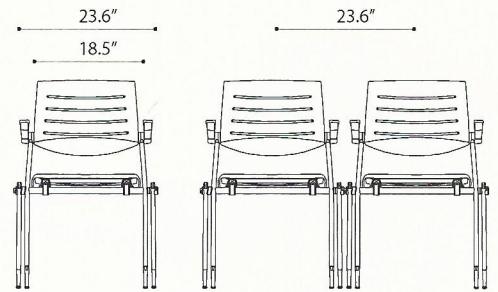
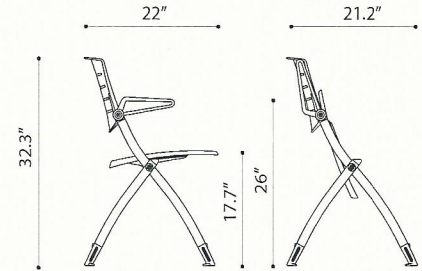

NORTWOOD

Formed laminated wood



NORTWOOD

Available with swing out base, task base, or four-leg base

FORMED LAMINATED WOOD

The Nortwood seat is elegant and comfortable—a straightforward design of thin layers of beech wood, precisely formed and laminated into a strong, single unit.

Available with swing out base, five-leg task base, or four-leg base.

SPECIFICATIONS

Our shells are made up of a minimum of 9 plies of European beech veneers for a total thickness of 12 mm (just under 1/2"). They are precision machined on 5-axis CNC routers. The PU lacquer is 100% water-base.



WOODY

Refined Italian design



Design: Giovanni Baccolini

Navetta™

WOODY

Waiting Seat

REFINED ITALIAN DESIGN

The Woody armchair is a typical example of refined Italian design. Functional, yet imbued with a strong personality, Woody is the ideal solution for furnishing any elegant or architecturally sophisticated surrounding.

SPECIFICATIONS

The shell is made of shaped beech plywood, varnished with aniline or padded and upholstered. The frame is made of chrome-plated or powder coated tubular steel. In the version on beam the leg is made of 15 ga. rectangular steel tube-approx. 2.4"x1.5"-welded to a 15 ga. oval steel tube foot-approx. 2.4"x1.2"-with two nylon feet. The bearing beam is made of 12 ga. rectangular steel tube-approx. 3"x1.5". The padding is filled with contoured polyurethane foam. The armrests can be in polyurethane, in aniline dyed beech, or in leather covered beech.

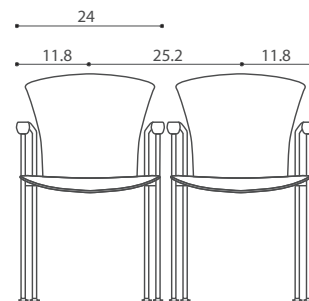
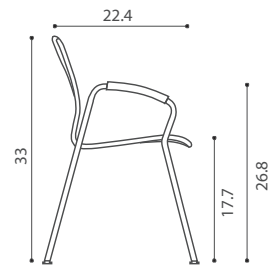
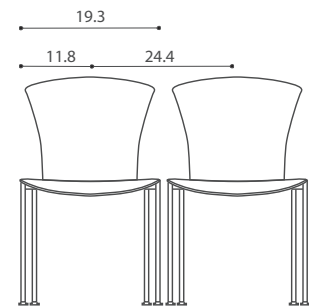
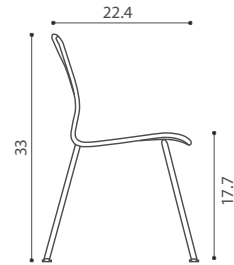

EURA

Perfect for any situation



Design: Giovanni Baccolini

Navetta™

EURA

Waiting Seat

PERFECT FOR ANY SITUATION

Eura stands out with a proud outline that makes it the perfect choice whenever a seat with character is required. The Elite version is enhanced with comfortable padding and elegant seams that add a particular elegance and make it ideal for executive offices or as a guest chair.

SPECIFICATIONS

The seat is made of 10 mm (approx. 0.4") natural beech plywood, padded and upholstered. The back is made of 10 mm (approx. 0.4") natural beech plywood, varnished with aniline or padded and upholstered, with back supports in nylon reinforced with 20 percent glass fiber with chromed metallized finishing. The plastic back is made of injection-molded polypropylene, with a slip-proof finish. It is available in black or translucent white. The mesh backrest is made of a painted steel rod frame, with a diameter of 12 mm (approx. 0.48"), covered with a mesh of black, white, or gray polyester; the back supports are made of nylon reinforced with 20 percent glass fiber, with chromed metallized finishing. The padding is made of contoured polyurethane foam: the seat thickness is approx. 2.2" for the Elite version and 1.8" for the Slim version. The density is of 2.5 pcf for both versions. The upholstered back has a thickness of approx. 1.2" and a density of 2.5 pcf. The structure is made of 12 ga. tubular steel frame with diameter of 25 mm (approx. 1"), varnished or chrome-plated. A black or nickel-plated galvanizing process protects all the small components.

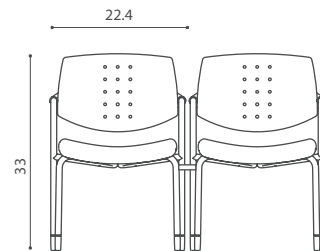
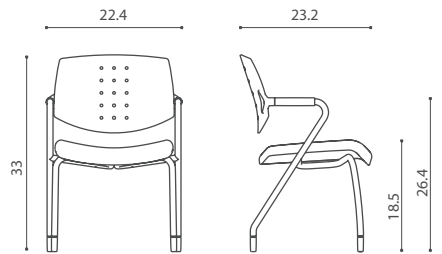
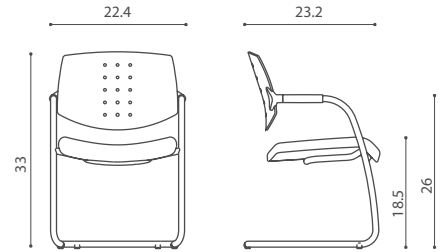

MYA

Design, comfort, and functionality



Design: Giovanni Baccolini

Navetta™

MYA

Waiting Seat

DESIGN, COMFORT, AND FUNCTIONALITY

Characterized by its single form, Mya distinguishes itself with its high degree of practicality, the accuracy of its finishing, and its multipurpose possibilities. Three different bases are available. The circular base, in stainless steel and with an essential and contemporary line, is the ideal solution for reception areas where design, comfort, and functionality merge.

SPECIFICATIONS

The structure is in tubular steel of different dimensions. Paddings are in self-extinguishing cold-foamed polyurethane. The disc-base is in stainless steel, swivel with fixed height. The fixed base on four legs is in tubular chrome-plated steel with adjustable feet. The five-star base is in polished aluminum. The dual-wheel self-braking castors are in reinforced nylon for soft floor or in polyurethane tread for hard floor. The fixed glides are in reinforced nylon. The table is made of 20 mm (approx. 0.8") thick wood conglomerate coated with white melamine. The legs are made of 10x20 mm (approx. 0.4"x0.8") chrome-plated oval tubular steel with chrome-plated finishing.

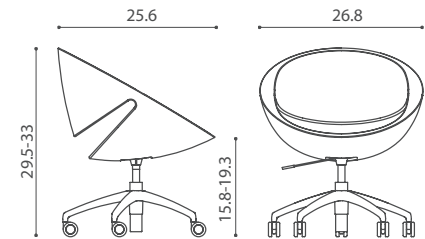
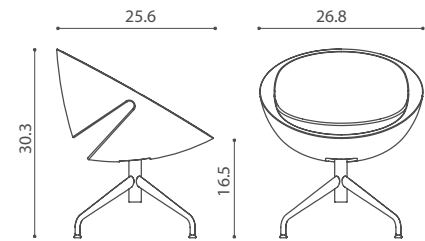
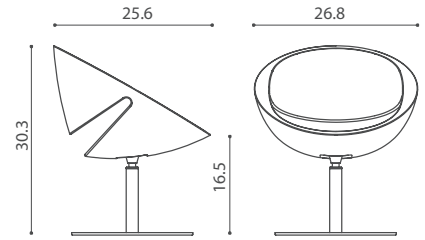

A photograph of two modern, blue upholstered chairs with a curved, ergonomic design. They are positioned around a light-colored glass coffee table with a white metal base. A small, dark, bowl-shaped object sits on the table. The background features a light-colored, vertically-paneled wall and framed artwork. The overall aesthetic is clean and contemporary.

TEOREMA

Elegant, dynamic seating

Design: Giovanni Baccolini

Navetta™

TEOREMA

Meeting Seat

ELEGANT, DYNAMIC SEATING

Developing Teorema was not an easy task. The objective was to create a new seating system for waiting areas that was elegant, dynamic, and creative—but, above all, extraordinary. Teorema accomplishes all this and more, adapting to spaces with harmony, creating new and different environments that are always stylish.

SPECIFICATIONS

The seat is made of tubular steel of various dimensions and the internal springs are composed of elastic belts. For the Teorema line, the leg frames are made of 12 ga. tubular steel with an elliptical section 76x25 mm (approx. 3"x1"); the feet are of 10 ga. sectional steel with section in the form of a 60 mm (approx. 2.4") equilateral triangle. Polypropylene weld closing and covering caps. The adjustable feet are of polypropylene. The arm pads are made of integral polyurethane or solid beech wood. All the exposed metal parts are painted with epoxy powders. The upholstered parts are padded with self-extinguishing polyurethane, the minimum density is 3.1 pcf. The intermediate and separate tables are available in 10 mm (approx. 0.4") thick tempered glass, sandblasted and varnished, with fixing plates of satin-finished stainless steel; or in 1" thick poplar agglomerate covered with anthracite colored HPL laminate, square-cut and edged with .08 inches thick ABS with a multi-layer design. In the Teorema line, a leg with a 9 ga. thick external fixing plate supports the intermediate tables.

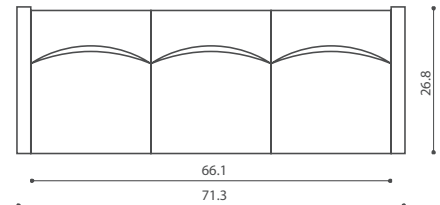
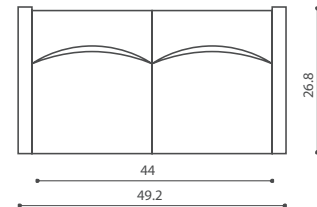
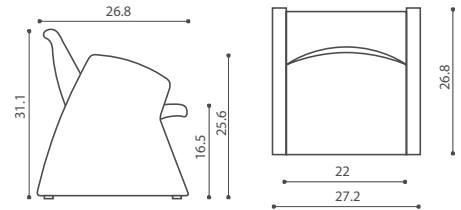

EIDOS

Innovative design and functionality



Design: Giovanni Baccolini

Navetta™

EIDOS

Theater/Auditorium Seat

INNOVATIVE DESIGN AND FUNCTIONALITY

Characterized by its great versatility and innovative design, Eidos includes a wide range of models. The Plus ensures maximum comfort in theaters and auditoriums. A wider seat with richer seams than the basic model, the row and place number elegantly embroidered on the side and under the seat, a side that extends to the ground—these are the elements that convey innovative design and functionality.

SPECIFICATIONS

The seat is made of 12 mm (approx. 0.47") beech plywood and the backrest and the optional headrest are made of 10 mm (approx. 0.4") beech plywood. In the wood version, the back is made of 13 mm (approx. 0.51") beech plywood, varnished in natural color, with a padded and upholstered panel. The padding of the seat is filled with self-extinguishing contoured polyurethane foam, with the average thickness of 2.75" and density of 2.5 psf. The padding of the backrest is filled with contoured polyurethane foam, with the average thickness of 2.75". The lower part of the rear backrest has a standard gray polypropylene cover, which also comes in black. The side is made of 11 ga. thick structural steel, with padded covering polypropylene panels. An optional end row side closed to the floor is made of wooden conglomerate. The armrests can be in black polypropylene, in fabric-covered polypropylene, or in natural varnished beech wood. All visible metal parts are scratchproof painted with epoxy powder in standard gray or in black. Frame finish: chrome or black or embossed gray epoxy-polyester coated.

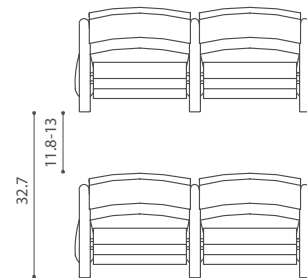
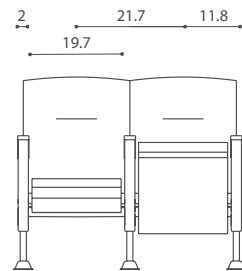
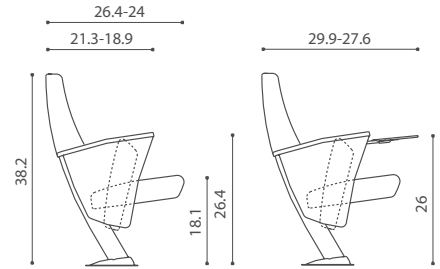

PREMIERE

Original aesthetic meets advanced technology



PREMIERE

Theater/Auditorium Seat

ORIGINAL AESTHETIC MEETS ADVANCED TECHNOLOGY

The strength of the Premiere line is its combination of technologically advanced solutions and new production methods. Aesthetics and function are given equal importance. The simple exterior conceals a wealth of features, exceptional comfort, and a precise design—a compact shape that blends the highest-quality materials and finishes

SPECIFICATIONS

The steel-framed seat and back are made of self-extinguishing polyurethane. The exterior of the seat and back are finished with curved beech plywood panels; the wood exteriors can be finished in lacquer or in engineered wood veneer on request. The chair gently closes silently and precisely in perfect alignment with the back thanks to a mechanism that cushions the movement. The sides are steel structures that house the mechanisms for allowing the synchronized opening and gentle closing of the seat. The 11 ga. steel support beam has a square cross-section and measures 3"x3". The chair's feet and the front handle are made of polished die-cast aluminum and have no visible screws.

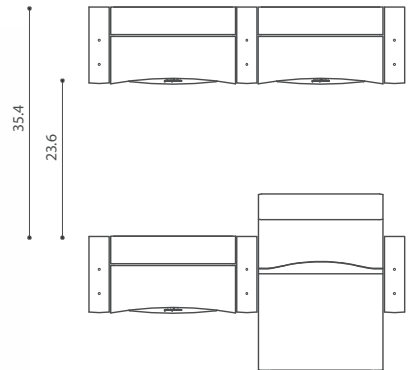
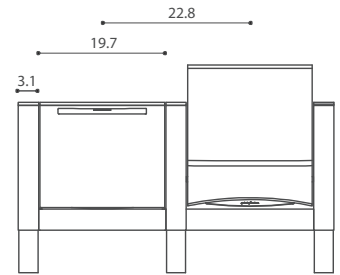
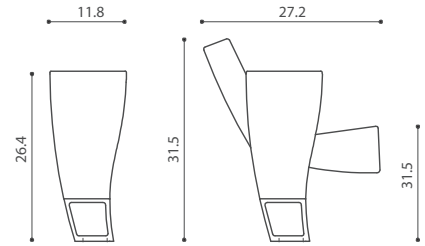

GENESIS

A new generation of armchairs



Design: Giovanni Baccolini

Navetta™

GENESIS

Theater/Auditorium Seat

A NEW GENERATION OF ARMCHAIRS

There is no better name for the splendid product that Giovanni Baccolini has drawn with his usual stylistic ability. It is a fabulous design that also has great planning capability. Based on an exclusive concept of body bolster (the true "heart" of the system), Genesis may, indeed, be considered the "origin" of a new generation of armchairs for public areas.

SPECIFICATIONS

Fully dismantlable armchair with separate elements. The seat is made of tubular steel with elasticized bearing belts while the backrest is made of 13.5 mm (approx. 0.53") beech plywood, varnished in natural color at sight, with a padded and upholstered beech panel or completely padded and upholstered and with the lower part of the rear backrest in painted sheet-steel. The padding of the seat is filled with polyurethane, with the average thickness of 3.75" and the minimum density 3.43 pcf. The side is made of structural steel with padded side panels, or in varnished wood. The armrests can be padded and upholstered or in natural varnished wood. The triangular bearing beam is made of extruded aluminum, with a base of 3.54" and a height of 4.72". The leg is made of 11 ga. 3.14" diameter circular tubular steel welded to an 8 ga. thick circular drawn steel foot with three holes for floor fixing.

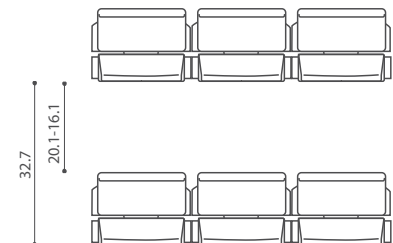
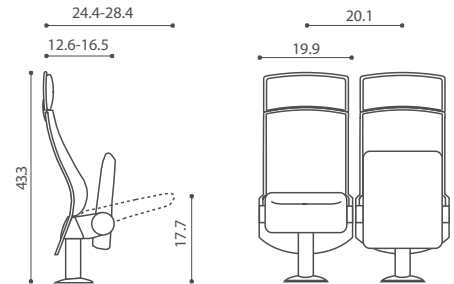
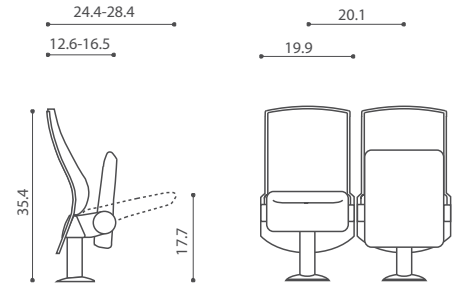

S400 CONTINA

Affordable comfort



Navetta™

S400 CONTINA

Theater/Auditorium Seat

AFFORDABLE COMFORT

The Contina Seating System provides elegant, comfortable, and reliable seating at an affordable price—perfect for auditoriums and other larger venues.

SPECIFICATIONS

For use in straight or curved-row configurations. For installation on flat, sloping, or tiered floors. The frame has a durable and environmentally-friendly electrostatically applied powder coat finish, oven-baked at 392 degrees F. Upholstered end panel with fixed arm is standard; fixed arm, with or without cup holder, is also available. Conventional style curved cushion back with anatomic or concave style cushion seat. Fabric choice: Absecon Mills, Johnston Textiles or Proquinal VinylBlack standard, other colors available. Seatback height: 32.5" or 35". Width available: From 19" to 22".

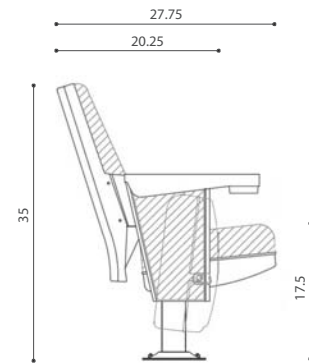
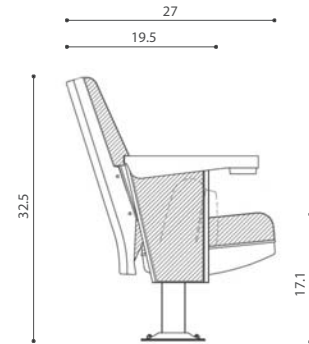

IMPORTANT: This guide provides a general overview of the standard colors available, however, due to limitations of digital images, individual monitor calibration, and/or the printing process, this is not a perfect representation. Before finalizing your color choices, we strongly recommend that you view physical samples. Other finishes are available, but some may result in increased cost or extended delivery time. Color availability subject to change without notice.

Edgeband and ComfortEdge Colors

(see larger images on back cover)

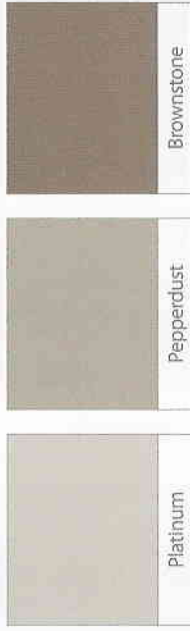

Symmetra Metal Powdercoat Finishes

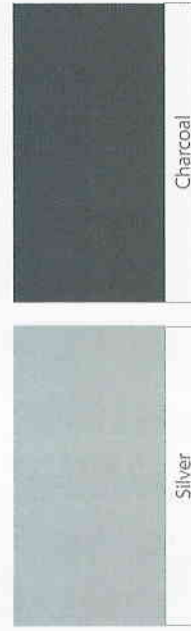

Monolito Metal—Anodized Aluminum Finish



Wilsonart Laminate Warm Patterns

(see larger images inside)



Wilsonart Laminate Cool Patterns

(see larger images inside)



Wilsonart Laminate Solids

(see larger images inside)



Wilsonart Laminate Woodgrains

(see larger images inside)





4669-60 Natural Tigris



4814-60 Tungsten EV



4656-60 Bronze Legacy



4674-60 Evening Tigris



4885-38 Green Soapstone



7949-38 Asian Night



4810-60 Titanium EV

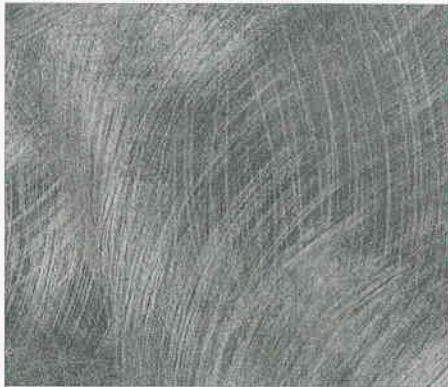

4779-60 Pewter Brush



4820-60 Carbon EV



4651-60 Navy Legacy

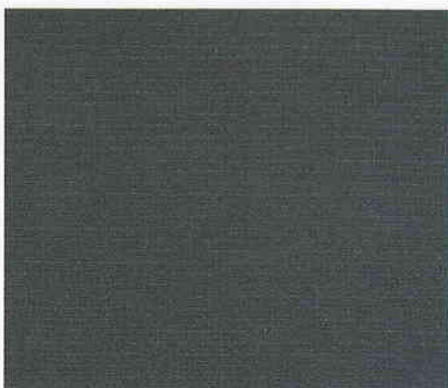

4880-38 Carbon Mesh



4623-60 Graphite Nebula

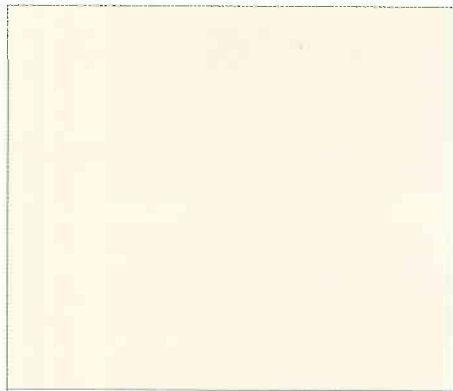

D403-60 White sand

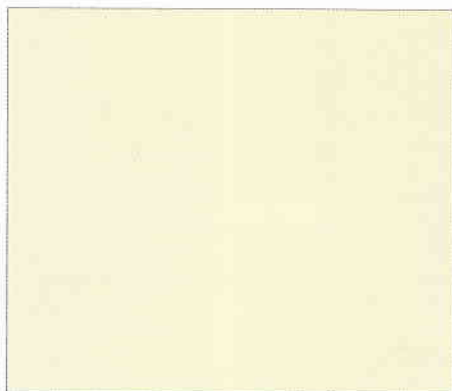

D456-60 Cafe Creme

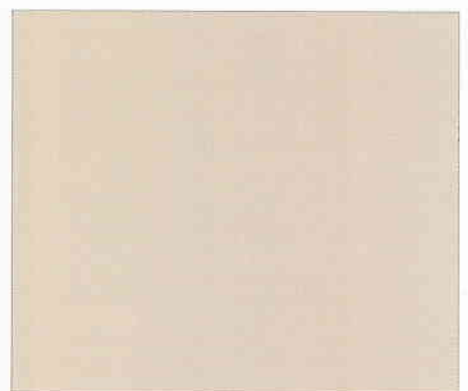

1530-60 Beige

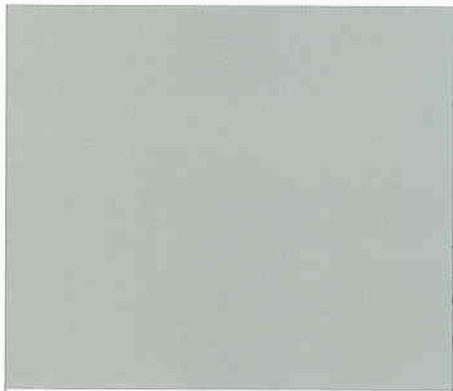

D92-60 Dove Grey

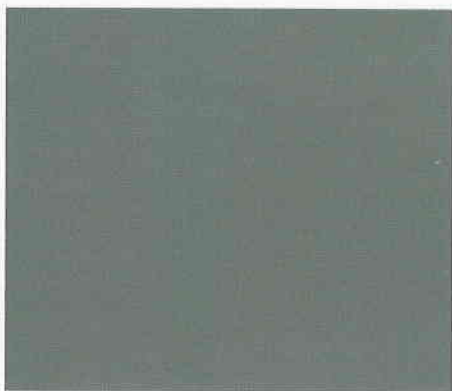

D90-60 North Sea

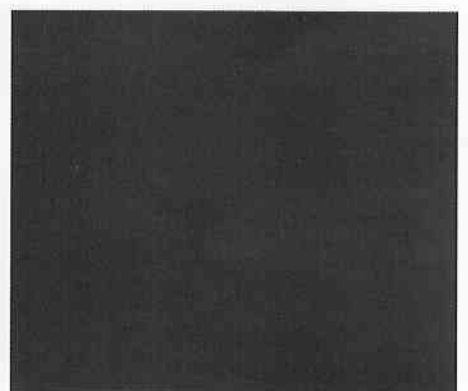

1595-60 Black

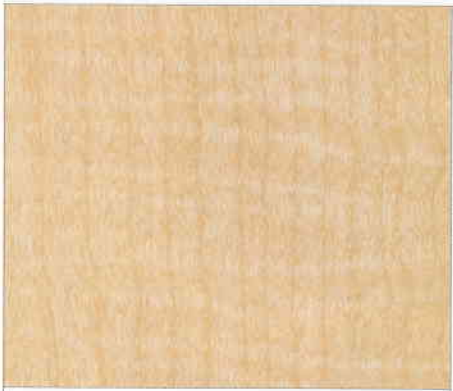

7909-60 Fusion Maple



7925-38 Monticello Maple



10745-60 Fonthill Pear



7054-60 Wild Cherry



7110T-60 Montana Walnut



7040A-60 Figured Mahogany

Edgeband and Comfort Edge Colors

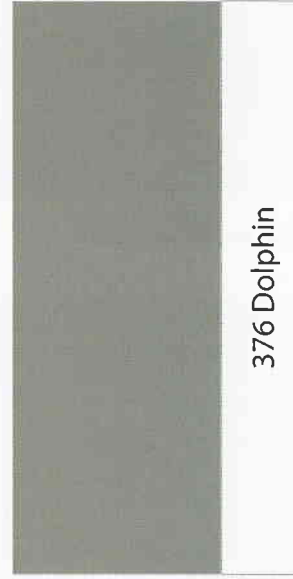
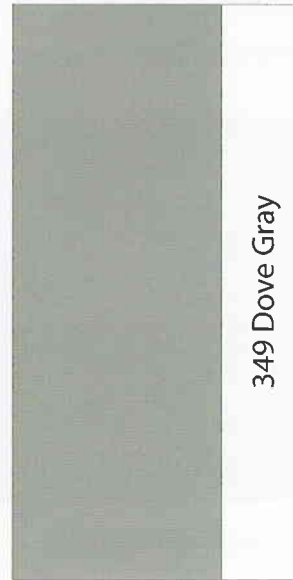
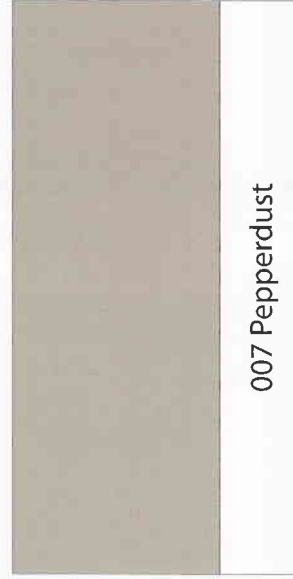
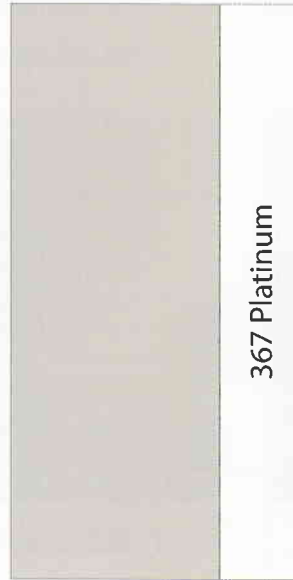
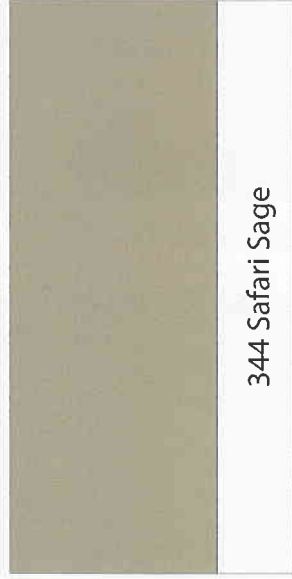
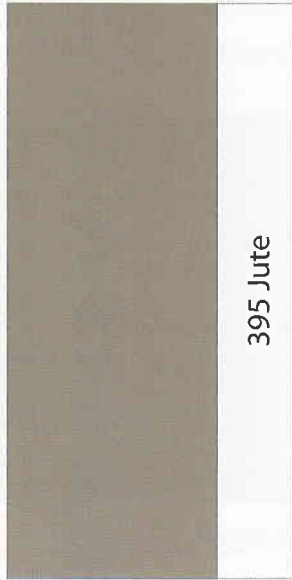
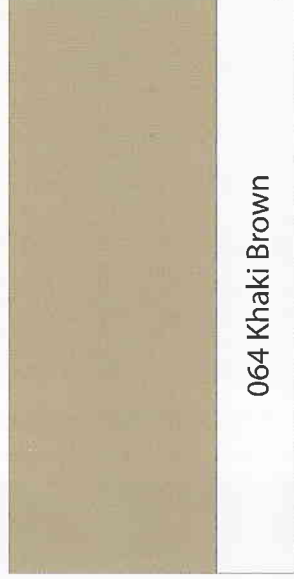
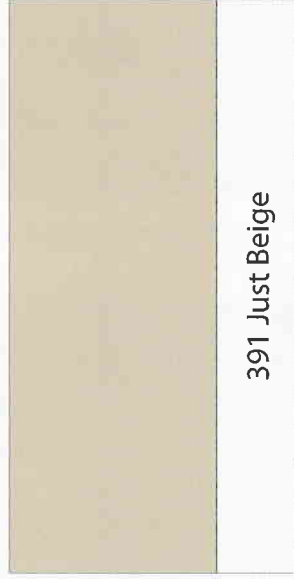
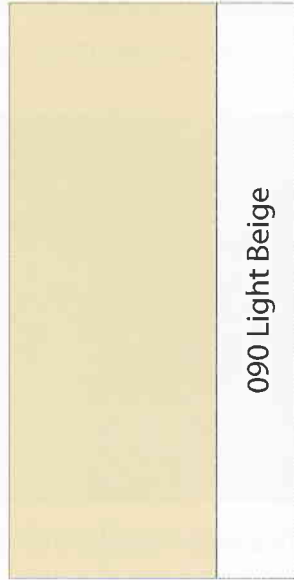

IMPORTANT: This guide provides a general overview of the standard colors available, however, due to limitations of digital images, individual monitor calibration, and/or the printing process, this is not a perfect representation. Before finalizing your color choices, we strongly recommend that you view physical samples. Other finishes are available, but some may result in increased cost or extended delivery time. Color availability subject to change without notice.

Navetta™

PLEASE BE SEATED

800.411.1979 / www.NavettaDesign.com



ShuttleSystem Computer Workstations

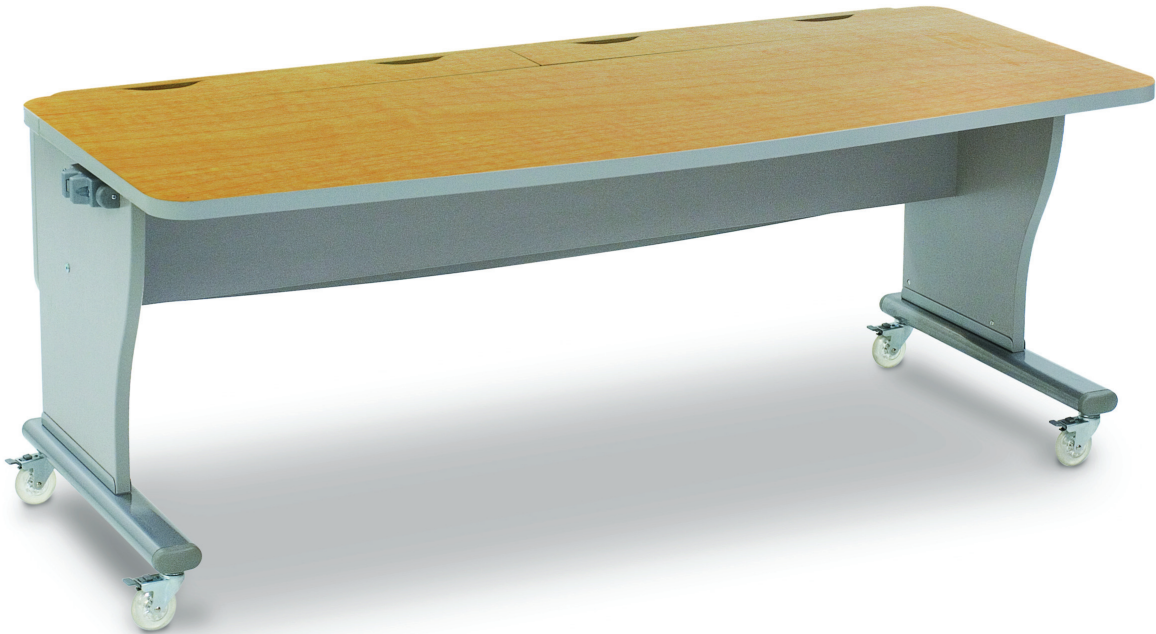

SHUTTLESYSTEM COMPUTER WORKSTATION
in 30x60 Wave Profile with casters



ORGANIZED FLEXIBILITY: Use the patented push-button ShuttleLatch to instantly connect workstations.

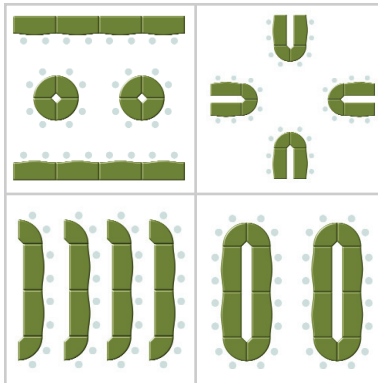



RESPONSIVE SPACES: When learning needs change, simply snap stations into a new configuration.



QUICK CHANGES: Top-loading wire management makes room changes quick and easy.

SHUTTLESYSTEM WORKSTATIONS

WAVE PROFILE	30D
	8 WIDTHS
Single Student:	30, 36, 42, 48
Multiple Student:	54, 60, 72

STRAIGHT PROFILE	30D
	8 WIDTHS
Single Student:	30, 36, 42, 48
Multiple Student:	54, 60, 72

CONFERENCE-END	66W x 30D
	
Left (curve on left end)	Seats 2
Right (curve on right end)	Seats 2

ShuttleSystem stations shown with optional Privacy Back and Sides



QUARTER PROFILE	52W x 30D
	Seats 1-2

HALF-OVAL PROFILE	62W x 33D
	60" diameter Seats 2-4

CORNER PROFILE	48SQ or 60SQ
	Seats 1

CORNER CONNECTOR	42W x 42D
	Seats 0

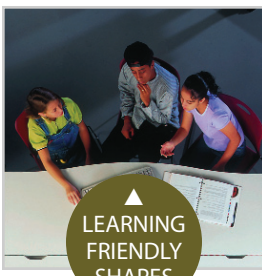

Curved shapes like the patented Wave Profile invite collaboration.

LEARNING FRIENDLY SHAPES

PRINTER STATIONS	30D
	2 WIDTHS
Single	24
Single 36	

OVERVIEW:

ShuttleSystem is the industry leader in organized flexibility, making it the perfect choice for computer labs and media centers equipped with wired desktop computers.

Modular, instantly-interlocking design facilitates quick room changes even in heavily-wired environments. Change from rows to team clusters in just minutes.

STANDARD FEATURES:

- Patented ShuttleLatch table connector
- Wire-management raceway
 - Top-loading for quick changes and easy access
 - Fully-integrated and oversized with wire access from top, bottom, back and sides
 - Internal data channel
- Rugged construction:
 - Premium hardware
 - 14-gauge steel foot tubes
 - Metal-to-metal bolted connections throughout
 - Contour PVC edging
- Integral modesty panel

OPTIONS:

- Glides or heavy-duty casters
- Three worksurface heights: 28, 25 or 31" ADA
- Locking raceway covers
- Upper panels
 - 8" raised backs
 - 18" privacy backs
 - 18" privacy backs and sides
- Modular electrical system
- CPU holders
- Sliding keyboard trays
- Storage pedestals: mobile or suspended
- Many color choices

800.411.1979
www.shuttlefurniture.com



ShuttleMate Computer Workstations

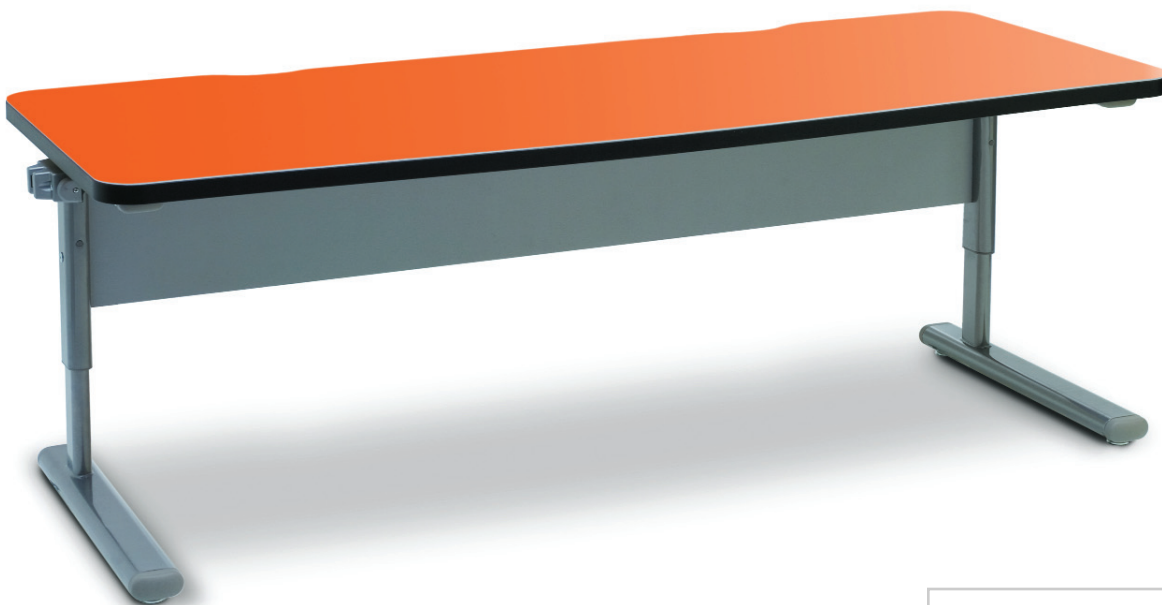

SHUTTLEMATE WAVE PROFILE
30 x 72 on casters

Choose from a full range of
modular shapes and sizes



Top-loading wire tray
attaches to modesty panel



Instantly connect modular
shapes with the ShuttleLatch



Select great options like the
power/data miniport



Adjustable legs available
with casters or glides

WAVE PROFILE



2 DEPTHS:
24, 30
7 WIDTHS:

Single Student: 30, 36, 42, 48
Multiple Student: 54, 60, 72

STRAIGHT PROFILE



2 DEPTHS:
24, 30
7 WIDTHS:

Single Student: 30, 36, 42, 48
Multiple Student: 54, 60, 72

CONFERENCE-END



2 SIZES:
66W x 30D
60W x 24D

Left (curve on left end) Seats 2
Right (curve on right end) Seats 2

PRINTER STATIONS



2 DEPTHS:
24, 30
3 WIDTHS:

26, 30, 36

QUARTER PROFILE



2 SIZES:
54W x 30D
45W x 24D
Seats 1-2

HALF-OVAL PROFILE



2 SIZES:
60W x 33D
48W x 27D
Seats 2-4

CORNER PROFILE



2 SIZES:
60W x 60D
48W x 48D
Seats 1

CORNER CONNECTOR 42W x 42D



Seats 0

SHUTTLEMATE INSTRUCTOR STATIONS

Conference Desk



60W x 30D
Left or Right

Instructor Stations may be used alone or combined with other ShuttleMate shapes and options

Conference Return



72W x 30D
Left or Right



OVERVIEW:

ShuttleMate Computer Tables offer all the ruggedness and flexibility of our flagship ShuttleSystem line but in a simpler, more economical design that's perfect for less wire-intensive applications.

Top-loading wire-management tray and push-button ShuttleLatch table connector make room changes quick and easy. Dozens of options let you suit ShuttleMate to your needs and school budget.

STANDARD FEATURES:

- Adjustable legs: 22" - 32"
- Integral modesty panel with wire grommets
- Rugged construction:
 - Premium hardware
 - 14-gauge steel legs
 - Metal-to-metal bolted connections throughout
 - PVC banded worksurfaces
- Many modular shapes and sizes

OPTIONS:

- Glides or heavy-duty casters
- Two depths: 24" or 30"
- Top-loading wire-management tray
- ShuttleLatch table connector
- Worksurface grommets
- Power/data miniport
- CPU holders
- Sliding keyboard trays
- Storage pedestals: mobile or suspended
- Many color choices

800.411.1979
www.shuttlefurniture.com

ShuttleZone Computer Tables



SHUTTLEZONE WAVE PROFILE
30 x 60 on casters



Choose from a full range of modular shapes and sizes



Streamlined design features designer steel support bar



Optional steel wire tray doubles as a modesty panel



Select great options like the power/data miniport



Adjustable legs available with casters or glides

WAVE PROFILE



2 DEPTHS:
24, 30
7 WIDTHS:

Single Student: 30, 36, 42, 48
Multiple Student: 54, 60, 72

STRAIGHT PROFILE



2 DEPTHS:
24, 30
7 WIDTHS:

Single Student: 30, 36, 42, 48
Multiple Student: 54, 60, 72

CONFERENCE-END



2 SIZES:
60W x 24D
60W x 30D

Left (curve on left end) Seats 2
Right (curve on right end) Seats 2

QUARTER PROFILE



2 SIZES:
54W x 30D
45W x 24D
Seats 1-2

HALF-OVAL PROFILE



2 SIZES:
60W x 33D
48W x 27D
Seats 2-4

CORNER PROFILE



2 SIZES:
60W x 60D
48W x 48D
Seats 1

CORNER CONNECTOR 42W x 42D



Seats 0

OVERVIEW:

With their streamlined design, ShuttleZone Computer Tables make ideal laptop tables, but they're also rugged enough for your heaviest equipment.

Combine modular shapes to create any kind of learning environment, then connect shapes with the ShuttleLatch table connector. The push-button release makes room changes quick and easy.

STANDARD FEATURES:

- Adjustable legs: 22" - 32"
- Streamlined design with low-profile steel support
- Rugged construction:
 - Premium hardware
 - 14-gauge steel legs
 - Metal-to-metal bolted connections throughout
 - PVC banded worksurfaces
- Many modular shapes and sizes

OPTIONS:

- Glides or heavy-duty casters
- Two depths: 24" or 30" (20" depth also available on a special-order basis)
- Steel modesty-height wire tray
- ShuttleLatch table connector
- Worksurface grommets
- Power/data miniport
- CPU holders
- Sliding keyboard trays
- Storage pedestals: mobile or suspended
- Many color choices



800.411.1979
www.shuttlefurniture.com

Tandem Starter / Adder Desks



TANDEM
30x48 Straight Profile



Contoured tops and grommeted sides neatly transfer wires



Oversized wire cavity with sliding doors in bottom provides easy access



"Semi-fixed" starter/adder design is more flexible than built-in systems

TANDEM FORMATS



STRAIGHT PROFILE 30D



Starter - Single Student: 30, 36, 48
 Starter - Multiple Student: 60, 72

Adder - Single Student: 30, 36, 48
 Adder - Multiple Student: 60, 72

CUSTOM WIDTHS:
 Any 1-inch increment from 30" to 72"

WAVE PROFILE 30D



Starter - Single Student: 30, 36, 48
 Starter - Multiple Student: 60, 72

Adder - Single Student: 30, 36, 48
 Adder - Multiple Student: 60, 72

CONFERENCE-END 66W x 30D



Starter - Left (curve on left side)
 Starter - Right (curve on right side)

Adder - Left (curve on left side)
 Adder - Right (curve on right side)

QUARTER PROFILE 38W x 30D



Starter
 Adder

CORNER CONNECTOR 45SQ x 30D



Starter
 Adder

Begin with a Starter...

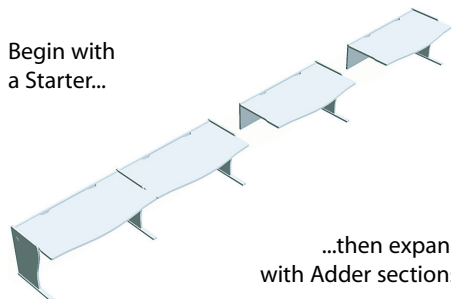

...then expand with Adder sections.

PRINTER STATION 24W x 30D



Starter
 Adder

OVERVIEW:

"Semi-fixed" starter/adder design is a better choice than traditional, built-in furniture

- Has all the structural integrity of built-in systems yet it's entirely reconfigurable
- Simple to install
- Durable and economical
- Many modular, learning-friendly shapes
- Customizable

STANDARD FEATURES:

- Wire-management channel
 - Integrated and concealed
 - sliding access doors
 - worksurface wire passage
- Rugged construction:
 - 14-gauge steel foot tubes
 - metal-to-metal bolted connections throughout
 - PVC banded side panels and worksurfaces
- Integrated modesty panel

OPTIONS:

- Three worksurface heights: 28", 25" or 31" ADA.
- Miniport: Worksurface-mounted pop-up power/data module
- 8" raised backs
- 18" upper privacy panels: side, back or combination
- Modular electrical system: flexible system enables reconfiguration; mounts in wire management channel
- Many color choices

800.411.1979
 www.shuttlefurniture.com

SHUTTLE'S COMMITMENT TO THE ENVIRONMENT



Shuttle's complete line of furniture has been certified under the rigorous GREENGUARD Children and SchoolsSM standards. Shuttle is committed to designing and crafting innovative learning environments, while always using materials and processes that respect and protect the environment.

The materials used to construct rugged Shuttle furniture include wood products made from 100% recycled and recovered wood fiber, structural components and hardware of recyclable steel, stainless steel, and aluminum, and recyclable injection-molded plastic components. We take extra steps during our design and manufacturing processes to minimize waste of each material. Computer-optimized manufacturing provides significant reductions in waste from panel parts by combining diverse part shapes from multiple products into single panels. Additionally, all wood product material meets the demanding specifications of the California Air Resources Board. Metal parts are robotically-cut, formed, and welded to reduce waste of these materials. Durable powdercoat metal finishes vastly reduce harmful emissions compared to conventional painting or electroplating processes. We work hand-in-hand with suppliers to minimize packaging materials used for subcomponents, and we recycle these materials. Our internal packaging process uses recyclable paper honeycomb material instead of polystyrene foam wherever possible. Excess cardboard remaining after forming boxes is cut and formed to provide protective filler strips. Our Ohio and Washington state facilities use energy-efficient lighting and HVAC systems, and our manufacturing and distribution facility was designed around an ultra-efficient low intensity radiant heater system, warming the occupants rather than the air, and replaced existing metal halide lighting with energy-efficient fluorescent fixtures. And at Shuttle, we never stop trying to improve our processes and materials.



Shuttle Furniture is certified under the rigorous GREENGUARD Children and SchoolSM standards

WE STAND BEHIND OUR PRODUCTS



OUR 15-YEAR WARRANTY

At Shuttle, we know how demanding schools are on furniture. We design for that, and more, backing our promise with a fifteen-year warranty:



All products are guaranteed against defective material and workmanship for a period of fifteen (15) years from date of actual receipt by the user.

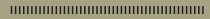

This warranty does not apply to any product which has been altered or modified from the original design or specification, or to any product damage resulting from accidents, negligence or shipping.



www.shuttlefurniture.com

1.800.411.1979

CUSTOM REQUESTS WELCOME

Although our standard products, with a wide selection of sizes, shapes, and configurations, meet the needs of most users, if you are interested in a custom design, please contact us. We look forward to your ideas.



Shuttle furniture is certified under the rigorous GREENGUARD Children and School standards

Features and specifications subject to change without notice.

Some products and features are covered by US Patents 5,878,673, D418042, D405991, D405979. Other patents may be pending. Shuttlesystem, ShuttleLatch, and ShuttleZone are registered trademarks. Shuttle, ShuttleMate, Tandem, Techera, Wave Profile, Forum Profile, Flux Desk and Open Space are trademarks of ShuttleSystem LLC. All contents Copyright 2010, ShuttleSystem LLC.

SHUTTLESYSTEM LLC
11340 Montgomery Road Suite 205
Cincinnati, Ohio 45249
Toll Free 800.411.1979
Phone 513.489.3727
Fax 513.489.7539
www.shuttlefurniture.com



ShuttleZone Student Desks & Tables



SHUTTLEZONE FORUM-PROFILE TWO-STUDENT TABLE
20x54 on Arc Legs with casters and molded book boxes

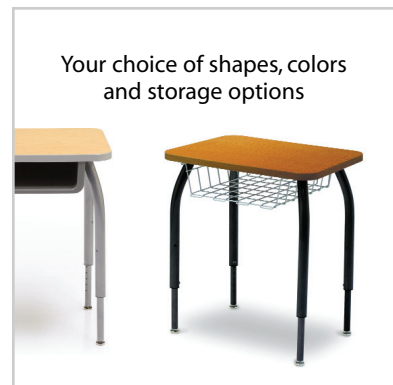
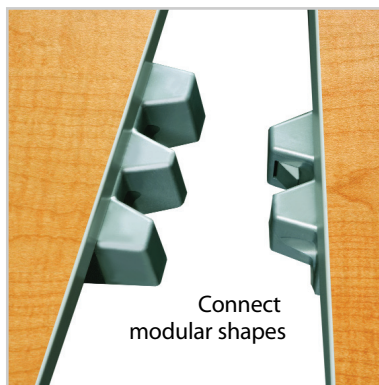
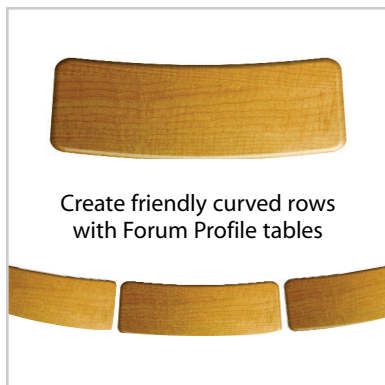

STRAIGHT PROFILE



3 DEPTHS:
20, 24, 30
8 WIDTHS:

Single Student: 26, 30, 36, 42, 48

Multiple Student: 54, 60, 72

FORUM PROFILE



3 DEPTHS:
20, 24, 30
8 WIDTHS:

Single Student: 26, 30, 36, 42, 48

Multiple Student: 54, 60, 72

WAVE PROFILE



3 DEPTHS:
20, 24, 30
8 WIDTHS:

Single Student: 26, 30, 36, 42, 48

Multiple Student: 54, 60, 72

TRAPEZOID



3 SIZES:

48W x 24D, 54W x 27D, 60W x 30D

KIDNEY



48W x 48D

LEG STYLES



Arc Leg - adjustable
22-31" | Glides



Arc Leg - fixed
29" | Glides or Casters

OVERVIEW:

ShuttleZone tables are specially designed to meet the needs and opportunities of today's changing schools. Available in a wide range of learning-friendly shapes and sizes, ShuttleZone tables turn ordinary classrooms, commons areas and conference rooms into versatile spaces that make technology and new ideas right at home.

STANDARD FEATURES:

- Full range of modular shapes and sizes
- Rugged construction:
 - Premium hardware
 - 14-gauge steel legs
 - Metal-to-metal bolted connections throughout
 - PVC banded worksurfaces

OPTIONS:

- Three depths: 20", 24" or 30"
- Choice of leg styles
- Adjustable or fixed height
- Glides or heavy-duty casters
- ShuttleLatch table connector
- Power/data miniport
- Many color choices

800.411.1979
www.shuttlefurniture.com

ShuttleZone Multi-Purpose Tables



SHUTTLEZONE CONFERENCE - END TABLES
on Arc Legs with locking casters

Reshape conference rooms
and commons instantly

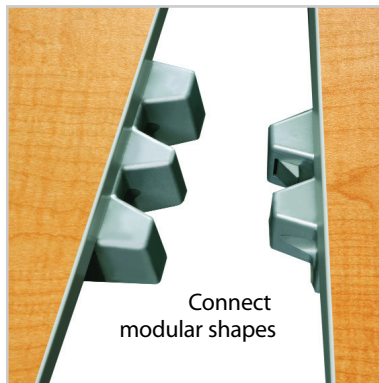

Connect
modular shapes

Choose from hundreds of
formats in many colors



STRAIGHT PROFILE



3 DEPTHS:
20, 24, 30
8 WIDTHS:

Single Student: 26, 30, 36, 42, 48

Multiple Student: 54, 60, 72

FORUM PROFILE



3 DEPTHS:
20, 24, 30
8 WIDTHS:

Single Student: 26, 30, 36, 42, 48

Multiple Student: 54, 60, 72

WAVE PROFILE



3 DEPTHS:
20, 24, 30
8 WIDTHS:

Single Student: 26, 30, 36, 42, 48

Multiple Student: 54, 60, 72

CORNER PROFILE



2 DEPTHS:
24, 30

2 SIZES:

42 or 48 square

CONFERENCE-END PROFILE



Left or Right

3 SIZES:

54W x 20D, 60W x 24D, 60W x 30D

HALF-ROUND PROFILE



3 SIZES:

48W x 24D, 54W x 27D, 60W x 30D

TRAPEZOID



3 SIZES:

48W x 24D, 54W x 27D, 60W x 30D

ROUND



5 SIZES:

36, 42, 48, 54, 60

KIDNEY



48W x 48D

LEG STYLES



Arc Leg - adjustable
22-31" | Glides



Arc Leg - fixed
29" | Glides or Casters



Pedestal Leg - adjustable
22-32" | Glides or Casters



OVERVIEW:

ShuttleZone tables are specially designed to meet the needs and opportunities of today's changing schools. Available in a wide range of learning-friendly shapes and sizes, ShuttleZone tables turn ordinary classrooms, commons areas and conference rooms into versatile spaces that make technology and new ideas right at home.

STANDARD FEATURES:

- Full range of modular shapes and sizes
- Rugged construction:
 - Premium hardware
 - 14-gauge steel legs
 - Metal-to-metal bolted connections throughout
 - PVC banded worksurfaces

OPTIONS:

- Three depths: 20", 24" or 30"
- Choice of leg styles
- Adjustable or fixed height
- Glides or heavy-duty casters
- Wire-management tray in modesty height
- ShuttleLatch table connector
- Worksurface grommets
- Power/data miniport
- CPU holders
- Sliding keyboard trays
- Storage pedestals
- Many color choices

800.411.1979
www.shuttlefurniture.com

Techera Instructor Workstation



TECHERA PLUS
right orientation, with two-drawer
pedestal and bookshelf return



Handy, pull-out work surface
tray included on all formats

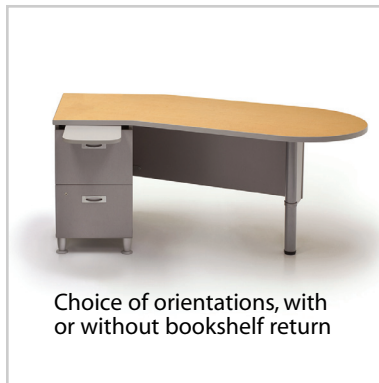

Choice of orientations, with
or without bookshelf return



Integral wiring system with
rear-access power strip

OVERVIEW:

Techera is the perfect instructor desk for technology-intensive learning environments like computer labs and media centers.

Smart wire-management, integral power and versatile storage options accommodate computers, supplies and electronic equipment seamlessly.

STANDARD FEATURES:

- Conference-shaped desk
- Modesty panel
- Handy, pull-out worksurface tray to expand desk space
- Sturdy storage pedestal in your choice of drawer and shelf configurations
- Technology-friendly design
 - Wire management system with locking, rear-access wiring cavity and 6-outlet power strip in all storage pedestals
 - Wire-passage in all shelves, side panels and worksurface
- Rugged construction:
 - Premium hardware throughout
 - 14-gauge steel leg
 - Metal-to-metal bolted connections throughout
 - PVC banded drawers, side panels and worksurfaces

OPTIONS:

- Left or right orientation
- Storage return with sturdy upper bookshelf
- Keyboard tray
- CPU holder
- Monitor well for improved eye contact
- Power/data miniport
- Many color choices

800.411.1979
www.shuttlesystem.com

DESK FORMATS

All formats 29" high.

Worksurface portion of desk is 30" deep.

Monitor Well option lowers computer monitor 3" below desk surface for improved eye contact with students. Monitor well is 16W x 9D.

TECHERA

36D X 72W



(no monitor well)



Monitor Well

Left or Right (right orientation shown above)

TECHERA PLUS

60D X 72W



(no monitor well)

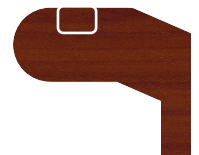

Monitor Well

Left or Right (right orientation shown above)

PEDESTAL STYLES

2 File Drawers

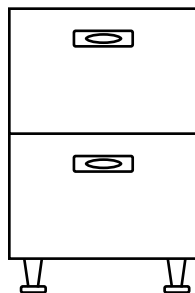

1 File Drawer
1 or 2 Small Drawers

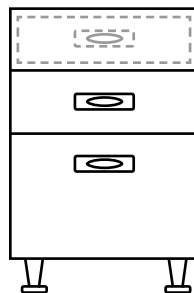

1 File Drawer
Shelves

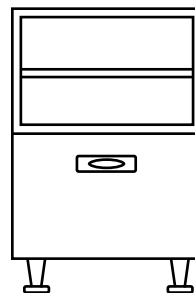

Open Shelves
(no door)

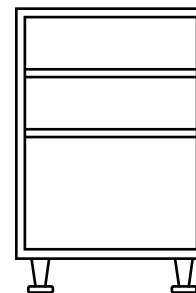

Shelves
with Door

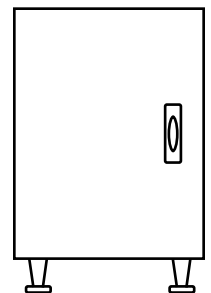

ShuttleZone Open Space Collection



SHUTTLEZONE FLUX DESK
with S Legs on Casters

SHUTTLEZONE STORAGE MODULE
in 29" desk height with locking File Drawer,
Paper Trays and upper Organizer Panel



Customize with drawers,
modesty panels and more



Standing height support
module doubles as a lectern



Expand your workspace
with many functional shapes

DESK SHAPES



Straight Desk

Flux Desk

Three sizes: 30x54, 30x60, 30x72

Mix with other mobile ShuttleZone shapes ▶

DESK LEG STYLES



S-Leg

Arc Leg

Pedestal Leg

Casters or Glides

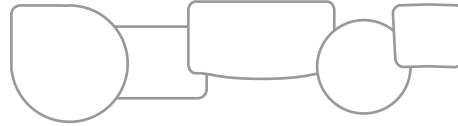

STORAGE MODULES

54W x 24D

2 HEIGHTS:

29" Desk Height

42" Standing Height

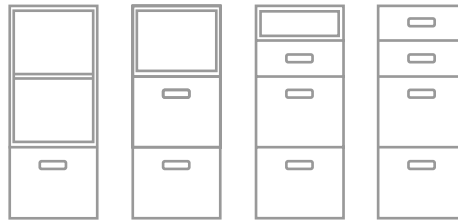
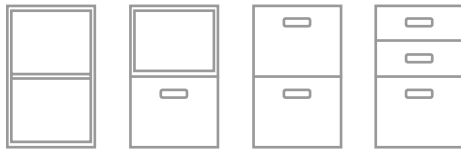
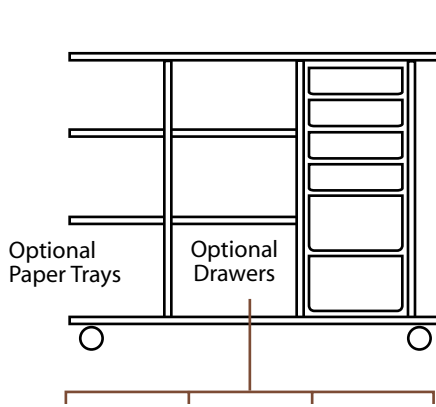
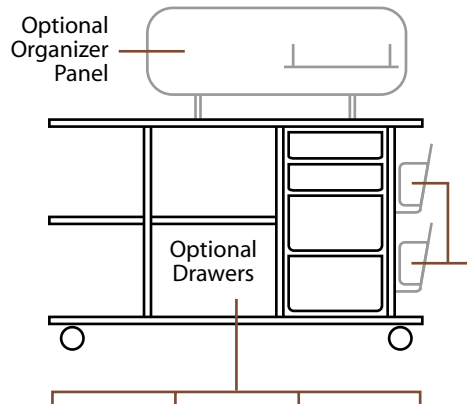

MOBILE STORAGE PEDESTALS

15W x 18D x 27H (sized to roll beneath 29" desks)

2 FORMATS:

- Two Drawer (File/File)
- Three Drawer (Box/Box/File)

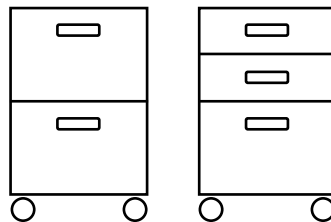

OVERVIEW:

The ShuttleZone Open Space Collection separates the traditional workspace into more manageable, technology-friendly pieces to suit today's more fluid classrooms. Desks and storage modules work alone or together and coordinate with other ShuttleZone shapes.

STANDARD FEATURES:

- Rugged desk construction:
 - premium hardware
 - 14-gauge steel legs
 - metal-to-metal bolted connections throughout
 - PVC banded worksurfaces
- Rugged storage construction:
 - steel-reinforced high-density particle board
 - vertical and horizontal bumper protection
 - rugged PVC edging
 - premium, heavy-duty hardware throughout

DESK OPTIONS:

- Two shapes in three sizes
- Choice of leg styles
- Glides or heavy-duty casters
- Modesty height wire tray
- Worksurface grommets
- Power/data miniport
- CPU holders
- Sliding keyboard trays
- Pencil drawers
- Mobile storage pedestals
- Many color choices

STORAGE RETURN OPTIONS:

- Locking drawers
- Upper organizer panel
- Hanging paper trays
- Many color choices

800.411.1979
www.shuttlefurniture.com

ShuttleZone Latching Pairs



SHUTTLEZONE CONFERENCE DESK
with Pedestal Legs on Casters and Wire Tray / Modesty Panel

SHUTTLEZONE STORAGE RETURN
in extended 72" length with locking file drawer

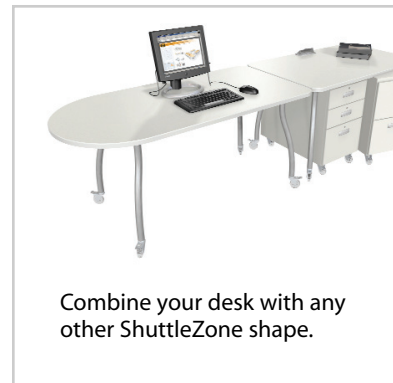
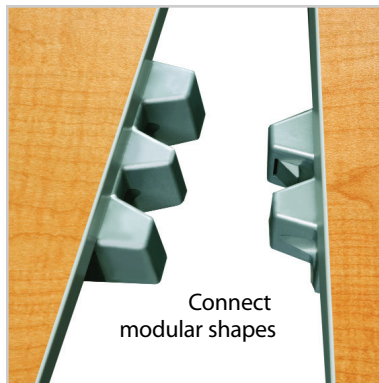

LATCHING DESK SHAPES

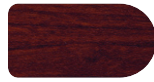

Straight Desk

Conference Desk

Three sizes: 30x54, 30x60, 30x72

Combine Latching Desks with Storage Returns or with dozens of other ShuttleZone shapes ▶

DESK LEG STYLES



S-Leg

Arc Leg

Pedestal Leg

Casters or Glides

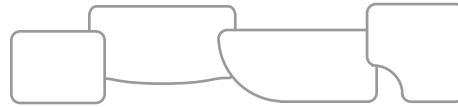

LATCHING STORAGE RETURNS

24D X 29H

2 LENGTHS:

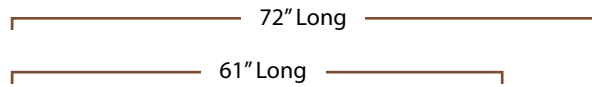

FEATURES + OPTIONS:

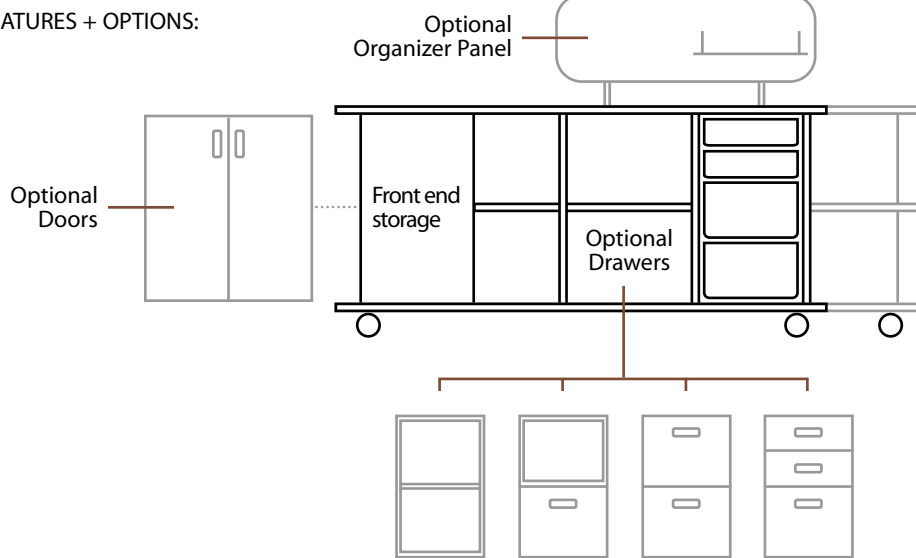

Included: four tote trays (two 3" / two 6"), integrated wire management, one adjustable shelf in front end storage area, casters, ShuttleLatch. Locks included on all optional drawers and doors.

MOBILE STORAGE PEDESTALS

15W x 18D x 27H (sized to roll beneath 29" desks)

2 FORMATS:

- Two Drawer (File/File)
- Three Drawer (Box/Box/File)

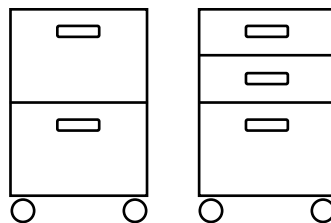

OVERVIEW:

Mobile, technology-friendly desks and storage units that instantly connect with the patented push-button ShuttleLatch. Use pieces alone or combine shapes.

STANDARD FEATURES:

- ShuttleLatch connector on all desks and on Storage Return
- Rugged desk construction:
 - premium hardware
 - 14-gauge steel legs
 - metal-to-metal bolted connections throughout
 - PVC banded worksurfaces
- Rugged storage construction:
 - steel-reinforced high-density particle board
 - vertical and horizontal bumper protection
 - rugged PVC edging
 - premium, heavy-duty hardware throughout

DESK OPTIONS:

- Two shapes in three sizes
- Choice of leg styles
- Glides or heavy-duty casters
- Modesty height wire tray
- Worksurface grommets
- Power/data miniport
- CPU holders
- Sliding keyboard trays
- Pencil drawers
- Mobile storage pedestals
- Many color choices

STORAGE RETURN OPTIONS:

- Locking drawers
- Upper organizer panel
- Locking front-end doors
- Many color choices

800.411.1979
www.shuttlefurniture.com

ShuttleZone Pedestal Desks



SHUTTLEZONE SINGLE PEDESTAL DESK
with 3-Drawer Pedestal, right orientation
with S-legs on casters



SHUTTLEZONE DOUBLE PEDESTAL DESK
with 2-Drawer Pedestal and 3-Drawer Pedestal
on glides

OVERVIEW:

ShuttleZone Pedestal Desks are the choice of educational professionals who need a quality, technology-friendly workspace at a reasonable price.

Three desk sizes are available with your choice of pedestal styles, all featuring handy slide-out worksurface trays that instantly expand your desk space. Customize your desk with storage and technology options to suit your specific needs.

STANDARD FEATURES:

- Rugged construction:
 - Premium hardware throughout
 - 14-gauge steel legs
 - Metal-to-metal bolted connections throughout
 - PVC edging
- Supporting Pedestals:
 - Six styles, casters or glides
 - Constructed of fully-laminated high-density particleboard anchored throughout with metal-to-metal connections
 - Integral metal drawer slides
 - Locking drawers and doors
 - Side and rear wire passage
 - Includes sturdy, sliding worksurface tray to extend desk space

OPTIONS:

- Choice of desk sizes
- Choice of five pedestal styles
- Choice of leg styles for Single Pedestal Desk
- Glides or heavy-duty casters
- Modesty panel
- Wire tray
- Worksurface grommets
- Power/data miniport
- CPU holders
- Sliding keyboard trays
- Pencil drawers
- Many color choices

800.411.1979
www.shuttlefurniture.com

SINGLE PEDESTAL DESK



Your choice of leg styles on Glides or Casters:
One Pedestal:

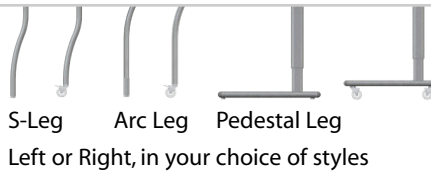

DOUBLE PEDESTAL DESK



Mix or match any two pedestals
Glides or Casters

Worksurface Sizes:



30D x 72W



30D x 60W



30D x 54W

Worksurface Sizes:

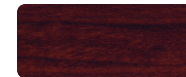

30D x 72W

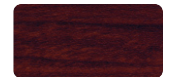

30D x 60W

PEDESTAL STYLES

All styles available on your choice of glides or casters

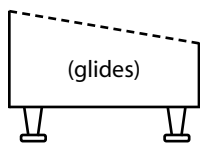

2 File Drawers

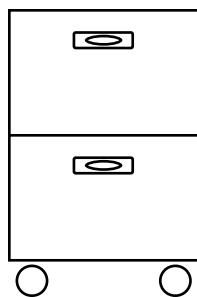

1 File Drawer
1 or 2 Small Drawers

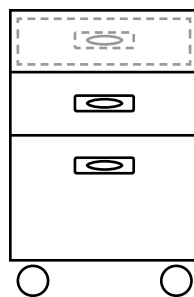

1 File Drawer
Shelves

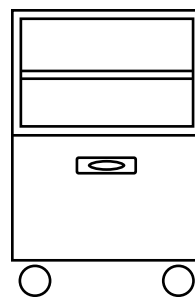

Open Shelves
(no door)



Shelves
with Door

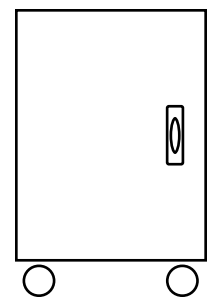

SHUTTLE'S COMMITMENT TO THE ENVIRONMENT





Shuttle's complete line of furniture has been certified under the rigorous GREENGUARD Children and SchoolsSM standards. Shuttle is committed to designing and crafting innovative learning environments, while always using materials and processes that respect and protect the environment.

The materials used to construct rugged Shuttle furniture include wood products made from 100% recycled and recovered wood fiber, structural components and hardware of recyclable steel, stainless steel, and aluminum, and recyclable injection-molded plastic components. We take extra steps during our design and manufacturing processes to minimize waste of each material. Computer-optimized manufacturing provides significant reductions in waste from panel parts by combining diverse part shapes from multiple products into single panels. Additionally, all wood product material meets the demanding specifications of the California Air Resources Board. Metal parts are robotically-cut, formed, and welded to reduce waste of these materials. Durable powdercoat metal finishes vastly reduce harmful emissions compared to conventional painting or electroplating processes. We work hand-in-hand with suppliers to minimize packaging materials used for subcomponents, and we recycle these materials. Our internal packaging process uses recyclable paper honeycomb material instead of polystyrene foam wherever possible. Excess cardboard remaining after forming boxes is cut and formed to provide protective filler strips. Our Ohio and Washington state facilities use energy-efficient lighting and HVAC systems, and our manufacturing and distribution facility was designed around an ultra-efficient low intensity radiant heater system, warming the occupants rather than the air, and replaced existing metal halide lighting with energy-efficient fluorescent fixtures. And at Shuttle, we never stop trying to improve our processes and materials.



Shuttle Furniture is certified under the rigorous GREENGUARD Children and SchoolSM standards

WE STAND BEHIND OUR PRODUCTS



OUR 15-YEAR WARRANTY

At Shuttle, we know how demanding schools are on furniture. We design for that, and more, backing our promise with a fifteen-year warranty:



All products are guaranteed against defective material and workmanship for a period of fifteen (15) years from date of actual receipt by the user.



This warranty does not apply to any product which has been altered or modified from the original design or specification, or to any product damage resulting from accidents, negligence or shipping.



www.shuttlefurniture.com

1.800.411.1979

CUSTOM REQUESTS WELCOME

Although our standard products, with a wide selection of sizes, shapes, and configurations, meet the needs of most users, if you are interested in a custom design, please contact us. We look forward to your ideas.



Shuttle furniture is certified under the rigorous GREENGUARD Children and School standards

Features and specifications subject to change without notice.

Some products and features are covered by US Patents 5,878,673, D418042, D405991, D405979. Other patents may be pending. Shuttlesystem, ShuttleLatch, and ShuttleZone are registered trademarks. Shuttle, ShuttleMate, Tandem, Techera, Wave Profile, Forum Profile, Flux Desk and Open Space are trademarks of ShuttleSystem LLC. All contents Copyright 2010, ShuttleSystem LLC.

SHUTTLESYSTEM LLC
11340 Montgomery Road Suite 205
Cincinnati, Ohio 45249
Toll Free 800.411.1979
Phone 513.489.3727
Fax 513.489.7539
www.shuttlefurniture.com



ShuttleZone Mobile Cabinets



Choice of 96 formats, twelve sizes, many options



Optional file drawers and project drawers



Integral wire-management for classroom electronics



Corners are metal-reinforced and finished with tough PVC



Premium hardware holds up to years of daily use



Professional-grade locking casters are triple welded

MOBILE CABINET FORMATS:

SIZES

all 24" deep

with your choice of storage options

3 WIDTHS:

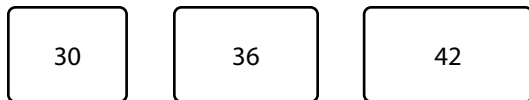

4 HEIGHTS:

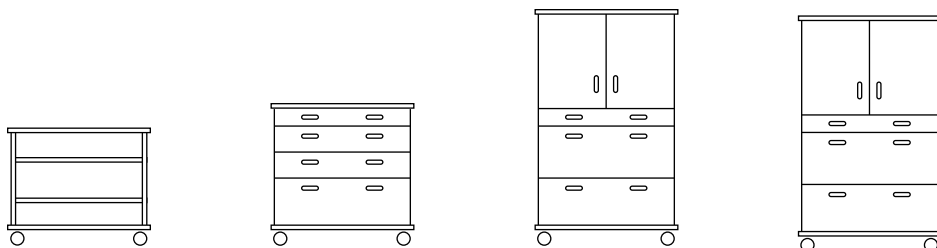

29" high

36" high

60" high

72" high

STORAGE OPTIONS

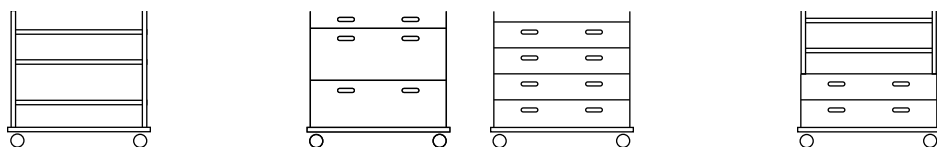

All Shelves

File Drawers and/or Project Drawers

Shelves + Drawers

DOOR OPTIONS

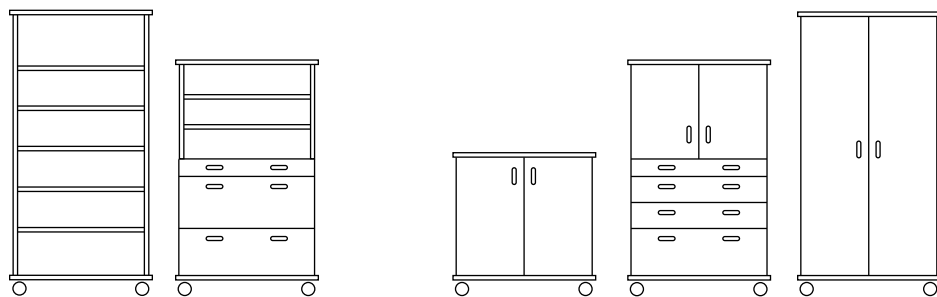

Open

With Doors

OVERVIEW:

Super-tough and transportable, ShuttleZone Mobile Cabinets offer a smarter, more flexible solution for managing supplies and classroom equipment – allowing storage to move easily within a room or to relocate from room to room as your needs change. Wire-management is built in to accommodate classroom technology seamlessly.

STANDARD FEATURES:

- Choice of 96 formats
- Rugged construction:
 - Steel reinforcement
 - Vertical and horizontal bumper protection
 - Rugged PVC edging
 - Premium hardware throughout
 - Heavy-duty casters
- Integral wire-management for classroom electronics

OPTIONS:

- Four heights; 29, 36, 60, 72
- Three widths; 30, 36, 42
- Optional file drawers and project drawers
- Optional locking doors
- Storage Totes
- Choice of base colors and worksurface colors

800.411.1979
www.shuttlefurniture.com

ShuttleZone Mobile Wardrobes



Add one or two locking file drawers to any wardrobe



96 formats, all with sturdy adjustable shelves



Integral wire-management for classroom electronics



Corners are metal-reinforced and finished with tough PVC



Premium hardware holds up to years of daily use



Professional-grade locking casters are triple welded

WARDROBE FORMATS:

SIZES

All 24" deep

3 WIDTHS:

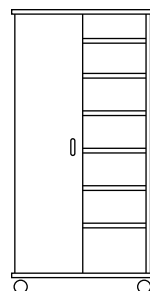
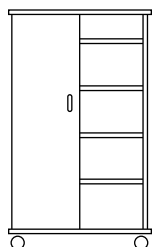
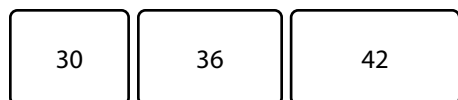

2 HEIGHTS:

60" high

72" high

FILE DRAWER OPTIONS

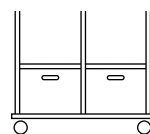
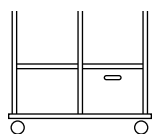
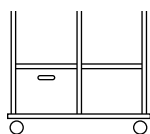
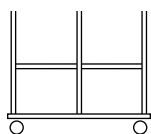

None

One - Left

One - Right

Two

DOOR OPTIONS

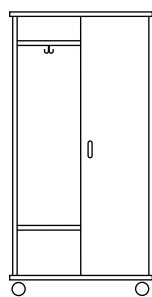
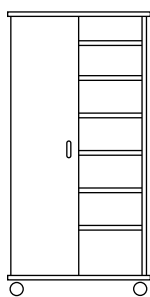
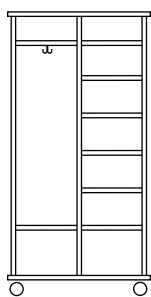

Open

Left

Right

Double

OVERVIEW:

Super-tough and transportable, ShuttleZone Mobile Wardrobes provide a smarter, more flexible solution for managing supplies, classroom equipment and teachers' personal belongings – allowing storage to easily move within a room or to relocate from room to room as your needs change.

STANDARD FEATURES:

- Choice of 96 formats
- Rugged construction:
 - Steel reinforcement
 - Vertical and horizontal bumper protection
 - Rugged PVC edging
 - Premium hardware throughout
 - Heavy-duty casters
- 24" deep
- Integral wire-management for classroom electronics

OPTIONS:

- Four heights; 29, 36, 60, 72
- Three widths; 30, 36, 42
- Optional file drawers
- Three styles
 - Open
 - Single Door
 - Double Door
- Storage totes

800.411.1979
www.shuttlefurniture.com

ShuttleZone Mobile Cubbies



SHUTTLEZONE MOBILE CUBBIE
in Open 29H x 48W format



Built ruggedly for constant,
daily movement



Roomy sections
for student
belongings or
class materials



Two widths and two heights,
with or without locking doors

MOBILE CUBBIES FORMATS:

SIZES

2 WIDTHS, all 20" deep:

48" Wide:

Open

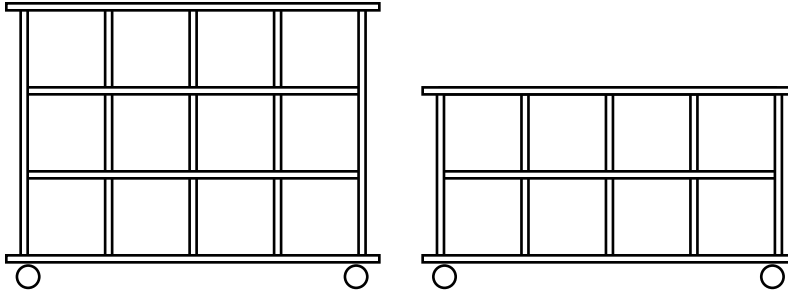

With Doors

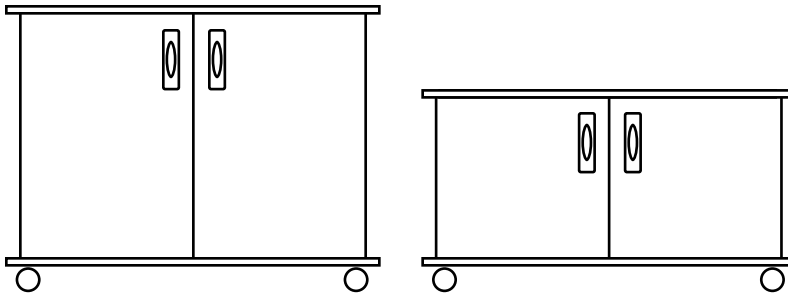

36" Wide:

Open

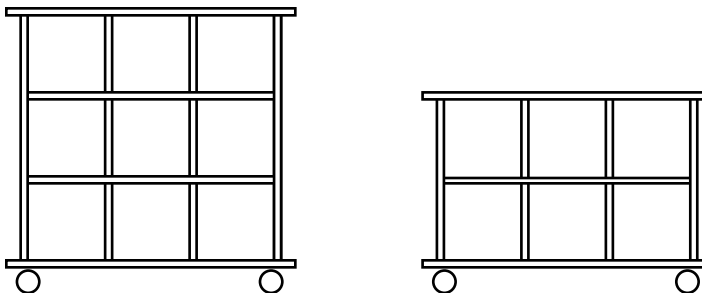

With Doors

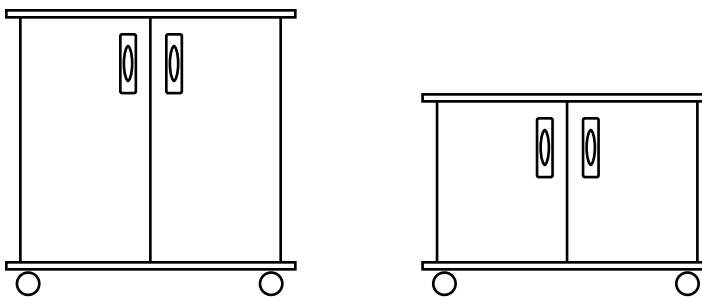

OVERVIEW:

Super-tough and transportable, ShuttleZone Mobile Cabinets offer a smarter, more flexible solution for managing supplies and classroom equipment – allowing storage to move easily within a room or to relocate from room to room as your needs change.

STANDARD FEATURES:

- Choice of 8 formats
- Rugged construction:
 - Steel reinforcement
 - Vertical and horizontal bumper protection
 - Rugged PVC edging
 - Premium hardware throughout
 - Heavy-duty casters

OPTIONS:

- Two heights; 29, 42
- Two widths; 30, 48
- Locking doors
- Color choices

800.411.1979
www.shuttlefurniture.com

ShuttleZone Satellite Support Module



SHUTTLEZONE SATELLITE SUPPORT MODULE
in 42" height with 4-drawers and vertical paper trays



Customize with drawers,
paper trays and upper shelf



Use alone or together with a
ShuttleZone Flux Desk

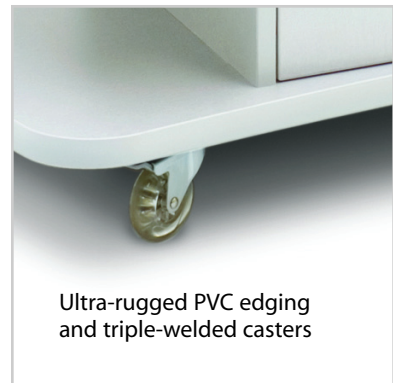

Ultra-rugged PVC edging
and triple-welded casters

STORAGE MODULES

54W x 24D

2 HEIGHTS:

29" Desk Height

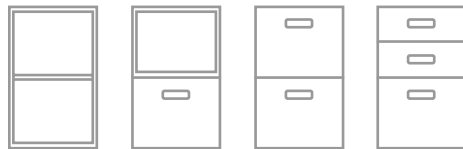
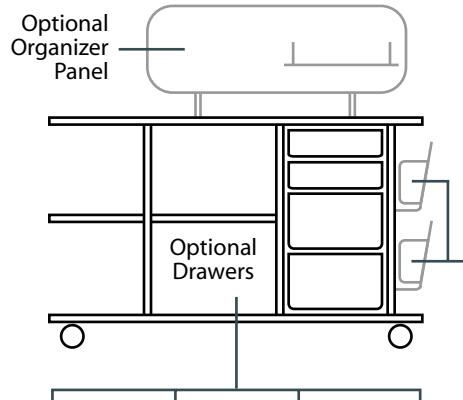

42" Standing Height

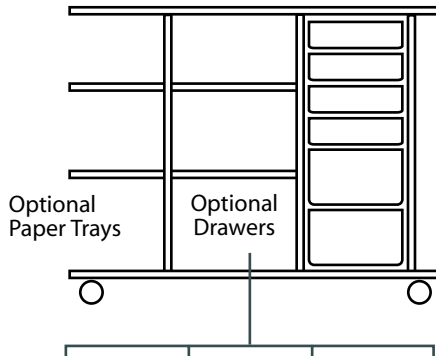

OVERVIEW:

ShuttleZone Satellite Support Modules transport supplies and materials wherever you need them. Choose from two heights; the desk height works great with our ShuttleZone Desks while the standing height doubles as a lectern. Customize your Satellite Support module with your choice of drawer configurations and great options like vertical paper trays and upper shelf panels.

STANDARD FEATURES:

- Steel-reinforced construction
- Vertical and horizontal bumper protection
- Rugged PVC edging
- Premium, heavy-duty hardware throughout
- Sliding tote trays
- Contemporary design

OPTIONS:

- Locking drawers
- Upper organizer panel
- Hanging paper trays
- Many color choices

800.411.1979
www.shuttlefurniture.com

ShuttleZone Stationary Cabinets



SHUTTLEZONE STATIONARY CABINET
30x72 with optional locking doors



Integral wire-management
for classroom electronics



Optional locking doors keep
equipment secure



Premium hardware holds up
to years of daily use



Choice of four heights and
three widths

STATIONARY CABINET FORMATS:

SIZES

all 16" deep

3 WIDTHS:

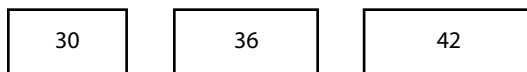

4 HEIGHTS:

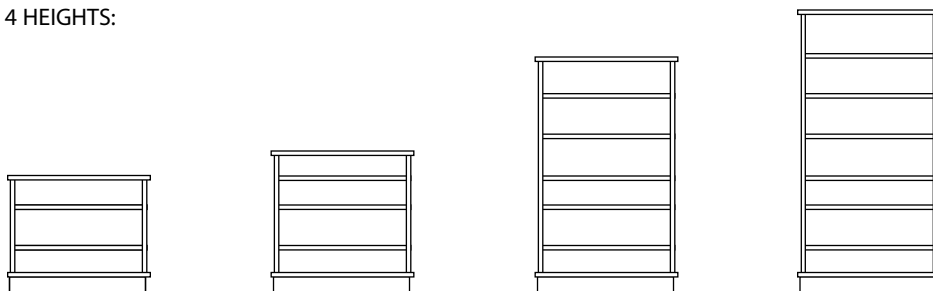

29" high

36" high

60" high

72" high

DOOR OPTIONS

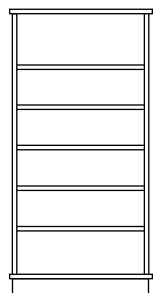

Open

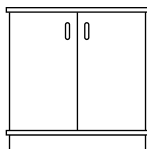

With Doors

STANDARD FEATURES:

- Choice of 24 formats
- Rugged construction:
 - Steel reinforcement
 - Rugged PVC edging
 - Premium hardware throughout
- Integral wire-management for classroom electronics

OPTIONS:

- Four heights; 29, 36, 60, 72
- Three widths; 30, 36, 42
- Optional locking doors
- Choice of base colors and worksurface colors

800.411.1979
www.shuttlefurniture.com

SHUTTLE'S COMMITMENT TO THE ENVIRONMENT





Shuttle's complete line of furniture has been certified under the rigorous GREENGUARD Children and SchoolsSM standards. Shuttle is committed to designing and crafting innovative learning environments, while always using materials and processes that respect and protect the environment.

The materials used to construct rugged Shuttle furniture include wood products made from 100% recycled and recovered wood fiber, structural components and hardware of recyclable steel, stainless steel, and aluminum, and recyclable injection-molded plastic components. We take extra steps during our design and manufacturing processes to minimize waste of each material. Computer-optimized manufacturing provides significant reductions in waste from panel parts by combining diverse part shapes from multiple products into single panels. Additionally, all wood product material meets the demanding specifications of the California Air Resources Board. Metal parts are robotically-cut, formed, and welded to reduce waste of these materials. Durable powdercoat metal finishes vastly reduce harmful emissions compared to conventional painting or electroplating processes. We work hand-in-hand with suppliers to minimize packaging materials used for subcomponents, and we recycle these materials. Our internal packaging process uses recyclable paper honeycomb material instead of polystyrene foam wherever possible. Excess cardboard remaining after forming boxes is cut and formed to provide protective filler strips. Our Ohio and Washington state facilities use energy-efficient lighting and HVAC systems, and our manufacturing and distribution facility was designed around an ultra-efficient low intensity radiant heater system, warming the occupants rather than the air, and replaced existing metal halide lighting with energy-efficient fluorescent fixtures. And at Shuttle, we never stop trying to improve our processes and materials.



Shuttle Furniture is certified under the rigorous GREENGUARD Children and SchoolSM standards

**WE STAND BEHIND
OUR PRODUCTS**



OUR 15-YEAR WARRANTY

At Shuttle, we know how demanding schools are on furniture. We design for that, and more, backing our promise with a fifteen-year warranty:



All products are guaranteed against defective material and workmanship for a period of fifteen (15) years from date of actual receipt by the user.



This warranty does not apply to any product which has been altered or modified from the original design or specification, or to any product damage resulting from accidents, negligence or shipping.



www.shuttlefurniture.com

1.800.411.1979

CUSTOM REQUESTS WELCOME

Although our standard products, with a wide selection of sizes, shapes, and configurations, meet the needs of most users, if you are interested in a custom design, please contact us. We look forward to your ideas.

SHUTTLESYSTEM LLC
11340 Montgomery Road Suite 205
Cincinnati, Ohio 45249
Toll Free 800.411.1979
Phone 513.489.3727
Fax 513.489.7539
www.shuttlefurniture.com

Features and specifications subject to change without notice.

Some products and features are covered by US Patents 5,878,673, D418042, D405991, D405979. Other patents may be pending. ShuttleSystem, ShuttleLatch, and ShuttleZone are registered trademarks. Shuttle, ShuttleMate, Tandem, Techera, Wave Profile, Forum Profile, Flux Desk and Open Space are trademarks of ShuttleSystem LLC. All contents Copyright 2010, ShuttleSystem LLC.



Shuttle furniture is certified under the rigorous GREENGUARD Children and School standards

CERTIFICATE

for

SHUTTLESYSTEM, LLC

4824 Socialville-Foster Rd, Suite 200
Mason, Ohio 45040 United States

CERTIFICATE SCOPE

Certificate Type: *Single Chain of Custody*
Standard(s): *FSC-STD-40-004 V2-1*

Product Group(s): *Parts of Furniture, Casework*
Valid from *February 28, 2017 to February 27, 2022*

Certificate Registration Code: *RA-COC-005816*

FSC® License Code: *FSC-C109523*

Certificate Issue Number: *IN-2017-1*

Additional details regarding the scope, including a full list of products and species are available at info.fsc.org.



Laura Terrall, Director, Certification

Rainforest Alliance
233 Broadway, 28th Floor
New York, NY 10279 USA

Rainforest Alliance is an FSC accredited certifier FSC® A000520

The validity of this certificate shall be verified on info.fsc.org. This certificate does not constitute evidence that a particular product supplied by the certificate holder is FSC certified and/or FSC Controlled Wood. Products offered, shipped or sold by the certificate holder can only be considered covered by the scope of this certificate when the required FSC claim is clearly stated on invoices and shipping documents.

This certificate is the property of Rainforest Alliance. This certificate and all copies or reproductions of this certificate shall be returned or destroyed if requested by Rainforest Alliance.



The mark of
responsible forestry

