

Agreements

Agreements for purchase will normally be put into effect by means of a contract, agreement, or purchase order(s) executed by authorized agents of the TIPS Member participating government entities, but other means of placing an order may be used at the Member's discretion. Vendor accepts and understands that when a purchase order or similar purchase document is sent from a customer through TIPS to the Vendor, TIPS is recording the purchase and verifying whether the purchase is within the parameters of the TIPS Contract only. Vendor agrees that TIPS is not a legal party to the purchase order or similar purchase document and TIPS is not responsible for identifying fraud, mistakes, or misrepresentations for the specific order. Vendor agrees that any purchase order or similar purchase document issued from a customer to Vendor, even when processed through TIPS, constitutes a legal contract between the customer and Vendor only. A Vendor that accepts a purchase order or similar purchase document and fulfills an order, even when processed through TIPS, is representing that the vendor has carefully reviewed the purchase order or similar purchase document for legality, authenticity, and accuracy.

Tax exempt status

Most TIPS Members are tax exempt and the related laws and/or regulations of the controlling jurisdiction(s) of the TIPS Member shall apply.

Assignments of Agreements

No assignment of this Agreement may be made without the prior notification of TIPS. Written approval of TIPS shall not be unreasonably withheld. Payment for delivered goods and services can only be made to the awarded Vendor, Vendor designated reseller or vendor assigned company.

Disclosures

- Vendor and TIPS affirm that he/she, or any authorized employees or agents, has not given, offered to give, nor intends to give at any time hereafter any economic opportunity, future employment, gift, loan, gratuity, special discount, trip, favor or service to a public servant in connection with this Agreement.
- Vendor shall attach, in writing, a complete description of any and all relationships that might be considered a conflict of interest in doing business with the TIPS program.
- The Vendor affirms that, to the best of his/her knowledge, the offer has been arrived at independently, and is submitted without collusion with anyone to obtain information or gain any favoritism that would in any way limit competition or give an unfair advantage over other vendors in the award of this Agreement.

Term of Agreement and Renewals

The Agreement with TIPS is for approximately **three (3)** years with an option for renewal for an additional **one (1)** consecutive **year**. If TIPS offers the renewal extension year, the Vendor will be notified by email to the primary contact of the awarded Vendor and shall be deemed accepted by the Vendor unless the awarded Vendor notifies TIPS of its objection to the additional term. TIPS may or may not exercise the available extension(s) provided in the original solicitation beyond the base **three-year** term. Whether or not to offer the extension is at the sole discretion of TIPS.

“Start Date” for Term Calculation Purposes Only: Regardless of actual award/effective date of Contract, for Agreement “term” calculation purposes only, the Agreement “start date” is the last day of the month that Award Notifications are anticipated as published in the Solicitation

Example: *If the anticipated award date published in the Solicitation is May 22, 2020 but extended negotiations delay award until June 27, 2020 The end date of the resulting initial “three-year” term Agreement, (which is subject to an extension(s)) will still be May 31, 2023.*

“Termination Date”: The scheduled Agreement “termination date” shall be the last day of the month of the month of the Original Solicitation’s Anticipated Award Date plus **three years**.

Example: *If the original term is approximately three years, and the solicitation provides an anticipated award date of May 22, 2020, the expiration date of the original three-year term shall be May 31, 2023.*

Extensions: Any extensions of the original term shall begin on the next day after the day the original term expires.

Example Following the Previous Example: *If TIPS offers a one-year extension, the expiration of the extended term shall be May 31, 2024.*

TIPS may offer to extend Vendor Agreements to the fullest extent the original Solicitation permits.

Automatic Renewal Clauses Incorporated in Awarded Vendor Agreements with TIPS Members Resulting from the Solicitation and with the Vendor Named in this Agreement.

No Agreement for goods or services with a TIPS Member by the awarded vendor named in this Agreement that results from the solicitation award named in this Agreement, may incorporate an automatic renewal clause that exceeds month to month terms with which the TIPS Member must comply. All renewal terms incorporated in an Agreement by the vendor with the TIPS Member shall only be valid and enforceable when the vendor receives written confirmation by purchase order, executed Agreement or other written instruction issued by the TIPS Member for any renewal period. The purpose of this clause is to avoid a TIPS Member inadvertently renewing an Agreement during a period in which the governing body of the TIPS Member has not properly appropriated and budgeted the funds to satisfy the Agreement renewal. This term is not negotiable and any Agreement between a TIPS Member and a TIPS awarded vendor with an automatic renewal clause that conflicts with these terms is rendered void and unenforceable.

Shipments

The Vendor shall ship, deliver or provide ordered products or services within a commercially reasonable time after the receipt of the order from the TIPS Member. If a delay in said delivery is anticipated, the Vendor shall notify TIPS Member as to why delivery is delayed and shall provide an estimated time for completion of the order. TIPS or the requesting entity may cancel the order if estimated delivery time is not acceptable or not as agreed by the parties.

Invoices

Each invoice or pay request shall include the TIPS Member’s purchase order number or other identifying designation as provided in the order by the TIPS Member. If applicable, the shipment tracking number or pertinent information for verification of TIPS Member receipt shall be made available upon request.

Payments

The TIPS Member will make payments directly to the Vendor, the Vendor Assigned Dealer or as agreed by the Vendor and the TIPS Member after receiving invoice and in compliance with applicable payment statute(s), whichever is the greater time or as otherwise provided by an agreement of the parties.

Pricing

Price increases will be honored according to the terms of the solicitation. All pricing submitted to TIPS shall include the participation fee, as provided in the solicitation, to be remitted to TIPS by the Vendor. Vendor will not show adding the fee to the invoice presented to TIPS Member customer.

Participation Fees and Reporting of Sales to TIPS by Vendor

The Participation Fee that was published as part of the Solicitation and the fee published is the legally effective fee, along with any fee conditions stated in the Solicitation. Collection of the fees by TIPS is required under Texas Government Code §791.011 Et seq. Fees are due on all TIPS purchases reported by either Vendor or Member. Fees are due to TIPS upon payment by the Member to the Vendor, Reseller or Vendor Assigned Dealer. Vendor, Reseller or Vendor Assigned Dealer agrees that the participation fee is due to TIPS for all Agreement sales immediately upon receipt of payment including partial payment, from the Member Entity and must be paid to TIPS at least on a monthly basis, specifically within 31 calendar days of receipt of payment, if not more frequently, or as otherwise agreed by TIPS in writing and signed by an authorized signatory of TIPS. Thus, when an awarded Vendor, Reseller or Vendor Assigned Dealer receives any amount of payment, even partial payment, for a TIPS sale, the legally effective fee for that amount is immediately due to TIPS from the Vendor and fees due to TIPS should be paid at least on a monthly basis, specifically within 31 calendar days of receipt of payment, if not more frequently.

Reporting of Sales to TIPS by Vendor

Vendor is required to report all sales under the TIPS contract to TIPS. When a public entity initiates a purchase with a TIPS Awarded Vendor, if the Member inquires verbally or in writing whether the Vendor holds a TIPS Contract, it is the duty of the Vendor to verify whether or not the Member is seeking a TIPS purchase. Once verified, the Vendor must include the TIPS Contract number on any communications and related sales documents exchanged with the TIPS Member entity. To report sales, the Vendor must login to the TIPS Vendor Portal online at https://www.tips-usa.com/vendors_form.cfm and click on the PO's and Payments tab. Pages 3-7 of the [Vendor Portal User Guide](#) will walk you through the process of reporting sales to TIPS. Please refer to the TIPS [Accounting FAQ's](#) for more information about reporting sales and if you have further questions, contact the Accounting Team at accounting@tips-usa.com. The Vendor or vendor assigned dealers are responsible for keeping record of all sales that go through the TIPS Agreement and submitting same to TIPS. Failure to render the participation fee to TIPS shall constitute a breach of this agreement with our parent governmental entity, Texas Education Service Center Region 8, as established by the Texas legislature and shall be grounds for termination of this agreement and any other agreement held with TIPS and possible legal action. Any overpayment of participation fees to TIPS by a Vendor will be refunded to the Vendor within ninety (90) days of receipt of notification if TIPS receives written notification of the overpayment not later than the expiration of six (6) months from the date of overpayment and TIPS determines that the amount was not legally due to TIPS pursuant to this agreement and applicable law. It is the Vendor's responsibility to identify which sales are TIPS Agreement sales and pay the correct participation fee due for TIPS Agreement sales. Any notification of overpayment received by TIPS after the expiration of six (6) months from the date of overpayment will be non-refundable. Region 8 ESC and TIPS reserve the right to extend the six (6) month deadline to notify if approved by the Region 8 ESC Board of Directors. TIPS reserves all rights under the law to collect the fees due. Please contact TIPS at tips@tips-usa.com or call (866) 839-8477 if you have questions about paying fees.

Indemnity

The Vendor agrees to indemnify and hold harmless and defend TIPS, TIPS Member(s), officers and employees from and against all claims and suits by third parties for damages, injuries to persons (including death),

property damages, losses, and expenses including court costs and reasonable attorney's fees, arising out of, or resulting from, Vendor's performance under this Agreement, including all such causes of action based upon common, constitutional, or statutory law, or based in whole or in part, upon allegations of negligent or intentional acts on the part of the Vendor, its officers, employees, agents, subcontractors, licensees, or invitees. Parties found liable shall pay their proportionate share of damages as agreed by the parties or as ordered by a court of competent jurisdiction over the case. **NO LIMITATION OF LIABILITY FOR DAMAGES FOR PERSONAL INJURY OR PROPERTY DAMAGE ARE PERMITTED OR AGREED BY TIPS/ESC REGION 8.** Per Texas Education Code §44.032(f), and pursuant to its requirements only, reasonable Attorney's fees are recoverable by the prevailing party in any dispute resulting in litigation.

State of Texas Franchise Tax

By signature hereon, the Vendor hereby certifies that he/she is not currently delinquent in the payment of any franchise taxes owed the State of Texas under Chapter 171, Tax Code.

Miscellaneous

The Vendor acknowledges and agrees that continued participation in TIPS is subject to TIPS sole discretion and that any Vendor may be removed from the participation in the Program at any time with or without cause. Nothing in the Agreement or in any other communication between TIPS and the Vendor may be construed as a guarantee that TIPS or TIPS Members will submit any orders at any time. TIPS reserves the right to request additional proposals for items or services already on Agreement at any time.

Purchase Order Pricing/Product Deviation

If a deviation of pricing/product on a Purchase Order or contract modification occurs between the Vendor and the TIPS Member, TIPS must be notified within five (5) business days of receipt of change order.

Termination for Convenience of TIPS Agreement Only

TIPS reserves the right to terminate this agreement for cause or no cause for convenience with a thirty (30) days prior written notice. Termination for convenience is conditionally required under Federal Regulations 2 CFR part 200 if the customer is using federal funds for the procurement. All purchase orders presented to the Vendor, but not fulfilled by the Vendor, by a TIPS Member prior to the actual termination of this agreement shall be honored at the option of the TIPS Member. The awarded Vendor may terminate the agreement with ninety (90) days prior written notice to TIPS 4845 US Hwy North, Pittsburg, Texas 75686. The vendor will be paid for goods and services delivered prior to the termination provided that the goods and services were delivered in accordance with the terms and conditions of the terminated agreement. This termination clause does not affect the sales agreements executed by the Vendor and the TIPS Member customer pursuant to this agreement. TIPS Members may negotiate a termination for convenience clause that meets the needs of the transaction based on applicable factors, such as funding sources or other needs.

TIPS Member Purchasing Procedures

Usually, purchase orders or their equal are issued by participating TIPS Member to the awarded vendor and should indicate on the order that the purchase is per the applicable TIPS Agreement Number. Orders are typically emailed to TIPS at tipspo@tips-usa.com.

- Awarded Vendor delivers goods/services directly to the participating member.
- Awarded Vendor invoices the participating TIPS Member directly.
- Awarded Vendor receives payment directly from the participating member.
- Fees are due to TIPS upon payment by the Member to the Vendor. Vendor agrees to pay the participation fee to TIPS for all Agreement sales upon receipt of payment including partial payment, from

the Member Entity or as otherwise agreed by TIPS in writing and signed by an authorized signatory of TIPS.

Licenses

Awarded Vendor shall maintain, in current status, all federal, state and local licenses, bonds and permits required for the operation of the business conducted by awarded Vendor. Awarded Vendor shall remain reasonably fully informed of and in compliance with all ordinances and regulations pertaining to the lawful provision of goods or services under the Agreement. TIPS and TIPS Members reserves the right to stop work and/or cancel an order or terminate this or any other sales Agreement of any awarded Vendor whose license(s) required for performance under this Agreement have expired, lapsed, are suspended or terminated subject to a 30-day cure period unless prohibited by applicable statute or regulation.

Novation

If awarded Vendor sells or transfers all assets, rights or the entire portion of the assets or rights required to perform this Agreement, a successor in interest must guarantee to perform all obligations under this Agreement. A simple change of name agreement will not change the Agreement obligations of awarded vendor. TIPS will consider Contract Assignments on a case by case basis. TIPS must be notified within five (5) business days of the transfer of assets or rights.

Site Requirements (*only when applicable to service or job*)

Cleanup: When performing work on site at a TIPS Member’s property, awarded Vendor shall clean up and remove all debris and rubbish resulting from their work as required or directed by TIPS Member or as agreed by the parties. Upon completion of work, the premises shall be left in good repair and an orderly, neat, clean and unobstructed condition.

Preparation: Awarded Vendor shall not begin a project for which TIPS Member has not prepared the site, unless awarded Vendor does the preparation work at no cost, or until TIPS Member includes the cost of site preparation in a purchase order. Site preparation includes, but is not limited to: moving furniture, installing wiring for networks or power, and similar pre-installation requirements.

Registered sex offender restrictions: For work to be performed at schools, awarded Vendor agrees that no employee of a subcontractor who has been adjudicated to be a registered sex offender will perform work at any time when students are, or reasonably expected to be, present unless otherwise agreed by the TIPS Member. Awarded Vendor agrees that a violation of this condition shall be considered a material breach and may result in the cancellation of the purchase order at the TIPS Member’s discretion. Awarded Vendor must identify any additional costs associated with compliance of this term. If no costs are specified, compliance with this term will be provided at no additional charge. **Safety measures:** Awarded Vendor shall take all reasonable precautions for the safety of employees on the worksite, and shall erect and properly maintain all necessary safeguards for protection of workers and the public. Awarded Vendor shall post warning signs against all hazards created by the operation and work in progress. Proper precautions shall be taken pursuant to state law and standard practices to protect workers, general public and existing structures from injury or damage.

Safety Measures

Awarded Vendor shall take all reasonable precautions for the safety of employees on the worksite, and shall erect and properly maintain all necessary safeguards for protection of workers and the public. Awarded vendor shall post warning signs against all hazards created by the operation and work in progress. Proper precautions shall be taken pursuant to state law and standard practices to protect workers, general public and existing structures from injury or damage.

Smoking

Persons working under Agreement shall adhere to the TIPS Member's or local smoking statutes, codes or policies.

Marketing

Awarded Vendor agrees to allow TIPS to use their name and logo within TIPS website, marketing materials and advertisement subject to any reasonable restrictions provided to TIPS in the Proposal to the Solicitation. The Vendor may submit an acceptable use directive for Vendor's names and logos with which TIPS agrees to comply. Any use of TIPS name and logo or any form of publicity, inclusive of press release, regarding this Agreement by awarded vendor must have prior approval from TIPS which will not be unreasonably withheld. Request may be made by email to TIPS@TIPS-USA.COM.

Supplemental Agreements

The TIPS Member entity participating in the TIPS Agreement and awarded Vendor may enter into a separate Supplemental Agreement or contract to further define the level of service requirements over and above the minimum defined in this Agreement such as but not limited to, invoice requirements, ordering requirements, specialized delivery, etc. Any Supplemental Agreement or contract developed as a result of this Agreement is exclusively between the TIPS Member entity customer and the Vendor. TIPS, its agents, TIPS Members and employees not a party to the Supplemental Agreement with the TIPS Member customer, shall not be made party to any claim for breach of such agreement unless named and agreed by the Party in question in writing in the agreement. If a Vendor submitting a Proposal requires TIPS and/or TIPS Member to sign an additional agreement, those agreements shall comply with the award made by TIPS to the Vendor. Supplemental Vendor's Agreement documents may not become part of TIPS' Agreement with Vendor unless and until an authorized representative of TIPS reviews and approves it. TIPS review and approval may be at any time during the life of this Vendor Agreement. TIPS permits TIPS Members to negotiate additional terms and conditions with the Vendor for the provision of goods or services under the Vendor's TIPS Agreement so long as they do not materially conflict with this Agreement.

Survival Clause

All applicable sales, leases, Supplemental Agreements, contracts, software license agreements, warranties or service agreements that were entered into between Vendor and TIPS or the TIPS Member Customer under the terms and conditions of this Agreement shall survive the expiration or termination of this Agreement. All Orders, Purchase Orders issued or contracts executed by TIPS or a TIPS Member and accepted by the Vendor prior to the expiration or termination of this agreement, shall survive expiration or termination of the Agreement, subject to previously agreed terms and conditions agreed by the parties or as otherwise specified herein relating to termination of this agreement.

Legal obligations

It is the responding Vendor's responsibility to be aware of and comply with all local, state and federal laws governing the sale of products/services identified in the applicable Solicitation that resulted in this Vendor Agreement and any awarded Agreement thereof. Applicable laws and regulations must be followed even if not specifically identified herein.

Audit rights

Due to transparency statutes and public accountability requirements of TIPS and TIPS Members', the awarded Vendor shall, at their sole expense, maintain appropriate due diligence of all purchases made by TIPS Member that utilizes this Agreement. TIPS and Region 8 ESC each reserve the right to audit the accounting of TIPS related purchases for a period of three (3) years from the time such purchases are made. This audit right shall survive termination of this Agreement for a period of one (1) year from the effective

date of termination. In order to ensure and confirm compliance with this agreement, TIPS shall have authority to conduct audits of Awarded Vendor's pricing or TIPS transaction documentation with TIPS Members with 30 days' notice unless the audit is ordered by a Court Order or by a Government Agency with authority to do so without notice. Notwithstanding the foregoing, in the event that TIPS is made aware of any pricing being offered to eligible entities that is materially inconsistent with the pricing under this agreement, TIPS shall have the ability to conduct the audit internally or may engage a third- party auditing firm to investigate any possible non- compliant conduct or may terminate the Agreement according to the terms of this Agreement. In the event of an audit, the requested materials shall be reasonably provided in the time, format and at the location acceptable to Region 8 ESC or TIPS. TIPS agrees not to perform a random audit the TIPS transaction documentation more than once per calendar year, but reserves the right to audit for just cause or as required by any governmental agency or court with regulatory authority over TIPS or the TIPS Member.

Force Majeure

If by reason of Force Majeure, either party hereto shall be rendered unable wholly or in part to carry out its obligations under this Agreement then such party shall give notice and full particulars of Force Majeure in writing to the other party within a reasonable time after occurrence of the event or cause relied upon, and the obligation of the party giving such notice, so far as it is affected by such Force Majeure, shall be suspended during the continuance of the inability then claimed, except as hereinafter provided, but for no longer period, and such party shall endeavor to remove or overcome such inability with all reasonable dispatch.

Choice of Law

The Agreement between the Vendor and TIPS/ESC Region 8 and any addenda or other additions resulting from this procurement process, however described, shall be governed by, construed and enforced in accordance with the laws of the State of Texas, regardless of any conflict of laws principles.

Venue, Jurisdiction and Service of Process

Any Proceeding arising out of or relating to this procurement process or any contract issued by TIPS resulting from or any contemplated transaction shall be brought in a court of competent jurisdiction in Camp County, Texas and each of the parties irrevocably submits to the exclusive jurisdiction of said court in any such proceeding, waives any objection it may now or hereafter have to venue or to convenience of forum, agrees that all claims in respect of the Proceeding shall be heard and determined only in any such court, and agrees not to bring any proceeding arising out of or relating to this procurement process or any contract resulting from or any contemplated transaction in any other court. The parties agree that either or both of them may file a copy of this paragraph with any court as written evidence of the knowing, voluntary and freely bargained for agreement between the parties irrevocably to waive any objections to venue or to convenience of forum. Process in any Proceeding referred to in the first sentence of this Section may be served on any party anywhere in the world. Venue for any dispute resolution process, other than litigation, between TIPS and the Vendor shall be located in Camp or Titus County, Texas.

Project Delivery Order Procedures

The TIPS Member having approved and signed an interlocal agreement, or other TIPS Membership document, may make a request of the awarded Vendor under this Agreement when the TIPS Member desires goods or services awarded to the Vendor. Notification may occur via phone, the web, courier, email, fax, or in person. Upon notification of a pending request, the awarded Vendor shall acknowledge the TIPS Member's request as soon as possible, but must make contact with the TIPS Member within two working days.

Status of TIPS Members as Related to This Agreement

TIPS Members stand in the place of TIPS as related to this agreement and have the same access to the proposal information and all related documents. TIPS Members have all the same rights under the awarded Agreement as TIPS.

Vendor’s Resellers as Related to This Agreement

Vendor’s Named Resellers (“Resellers”) under this Agreement shall comply with all terms and conditions of this agreement and all addenda or incorporated documents. All actions related to sales by Authorized Vendor’s Resellers under this Agreement are the responsibility of the awarded Vendor. If Resellers fail to report sales to TIPS under your Agreement, the awarded Vendor is responsible for their contractual failures and shall be billed for the fees. The awarded Vendor may then recover the fees from their named reseller.

Support Requirements

If there is a dispute between the awarded Vendor and TIPS Member, TIPS or its representatives may, at TIPS sole discretion, assist in conflict resolution if requested by either party. TIPS, or its representatives, reserves the right to inspect any project and audit the awarded Vendor’s TIPS project files, documentation and correspondence related to the requesting TIPS Member’s order. If there are confidentiality requirements by either party, TIPS shall comply to the extent permitted by law.

Incorporation of Solicitation

The TIPS Solicitation which resulted in this Vendor Agreement, whether a Request for Proposals, the Request for Competitive Sealed Proposals or Request for Qualifications solicitation, or other, the Vendor’s response to same and all associated documents and forms made part of the solicitation process, including any addenda, are hereby incorporated by reference into this Agreement as if copied verbatim.

SECTION HEADERS OR TITLES

THE SECTON HEADERS OR TITLES WITHIN THIS DOCUMENT ARE MERELY GUIDES FOR CONVENIENCE AND ARE NOT FOR CLASSIFICATION OR LIMITING OF THE RESPONSIBILITES OF THE PARTIES TO THIS DOCUMENT.

STATUTORY REQUIREMENTS

Texas governmental entities are prohibited from doing business with companies that fail to certify to this condition as required by Texas Government Code Sec. 2270.

By executing this agreement, you certify that you are authorized to bind the undersigned Vendor and that your company (1) does not boycott Israel; and (2) will not boycott Israel during the term of the Agreement.

You certify that your company is not listed on and does not and will not do business with companies that are on the Texas Comptroller of Public Accounts list of Designated Foreign Terrorists Organizations per Texas Gov’t Code 2270.0153 found at <https://comptroller.texas.gov/purchasing/docs/foreign-terrorist.pdf>

You certify that if the certified statements above become untrue at any time during the life of this Agreement that the Vendor will notify TIPS within three (3) business day of the change by a letter on Vendor’s letterhead from and signed by an authorized representative of the Vendor stating the non-compliance decision and the TIPS Agreement number and description at:

Attention: General Counsel

ESC Region 8/The Interlocal Purchasing System (TIPS)
4845 Highway 271 North
Pittsburg, TX,75686
And by an email sent to bids@tips-usa.com

Insurance Requirements

The undersigned Vendor agrees to maintain the below minimum insurance requirements for TIPS Contract Holders:

General Liability	\$1,000,000 each Occurrence/ Aggregate
Automobile Liability	\$300,000 Includes owned, hired & non-owned
Workers' Compensation	Statutory limits for the jurisdiction in which the Vendor performs under this Agreement.
Umbrella Liability	\$1,000,000

When the Vendor or its subcontractors are liable for any damages or claims, the Vendor's policy, when the Vendor is responsible for the claim, must be primary over any other valid and collectible insurance carried by the Member. Any immunity available to TIPS or TIPS Members shall not be used as a defense by the contractor's insurance policy. The coverages and limits are to be considered minimum requirements and in no way limit the liability of the Vendor(s). Insurance shall be written by a carrier with an A-; VII or better rating in accordance with current A.M. Best Key Rating Guide. Only deductibles applicable to property damage are acceptable, unless proof of retention funds to cover said deductibles is provided. "Claims made" policies will not be accepted. Vendor's required minimum coverage shall not be suspended, voided, cancelled, non-renewed or reduced in coverage or in limits unless replaced by a policy that provides the minimum required coverage except after thirty (30) days prior written notice by certified mail, return receipt requested has been given to TIPS or the TIPS Member if a project or pending delivery of an order is ongoing. Upon request, certified copies of all insurance policies shall be furnished to the TIPS or the TIPS Member.

Special Terms and Conditions

- **Orders:** All Vendor orders received from TIPS Members must be emailed to TIPS at tipspo@tips-usa.com. Should a TIPS Member send an order directly to the Vendor, it is the Vendor's responsibility to forward a copy of the order to TIPS at the email above within 3 business days and confirm its receipt with TIPS.
- **Vendor Encouraging Members to bypass TIPS agreement:** Encouraging TIPS Members to purchase directly from the Vendor or through another agreement, when the Member has requested using the TIPS cooperative Agreement or price, and thereby bypassing the TIPS Agreement is a violation of the terms and conditions of this Agreement and will result in removal of the Vendor from the TIPS Program.
- **Order Confirmation:** All TIPS Member Agreement orders are approved daily by TIPS and sent to the Vendor. The Vendor should confirm receipt of orders to the TIPS Member (customer) within 3 business days.
- **Vendor custom website for TIPS:** If Vendor is hosting a custom TIPS website, updated pricing when effective. TIPS shall be notified when prices change in accordance with the award.
- **Back Ordered Products:** If product is not expected to ship within the time provided to the TIPS

Member by the Vendor, the Member is to be notified within 3 business days and appropriate action taken based on customer request.

The TIPS Vendor Agreement Signature Page is inserted here.

TIPS Vendor Agreement Signature Form

RFP 210905 Gym Floors, Repairs, Replacements and Services PART 1 ONLY

Company Name Zoche LLC

Address 130 N Wilson St.

City Burleson State TX Zip 76028

Phone 817.246.2223 Fax _____

Email of Authorized Representative michael@zochellc.net

Name of Authorized Representative Michael Hunter

Title President

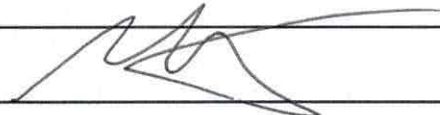
Signature of Authorized Representative 

Date 10.18.21

TIPS Authorized Representative Name David Fitts

Title Executive Director

TIPS Authorized Representative Signature David Wayne Fitts

Approved by ESC Region 8 David Wayne Fitts

Date 11/18/2021

NOTICE TO MEMBERS REGARDING ATTRIBUTE RESPONSES

TIPS VENDORS RESPOND TO ATTRIBUTE QUESTIONS AS PART OF TIPS COMPETITIVE SOLICITATION PROCESS. THE VENDOR'S RESPONSES TO ATTRIBUTE QUESTIONS ARE INCLUDED HEREIN AS "SUPPLIER RESPONSE." PLEASE BE ADVISED THAT DEVIATIONS, IF ANY, IN VENDOR'S RESPONSE TO ATTRIBUTE QUESTIONS MAY NOT REFLECT VENDOR'S FINAL ATTRIBUTE RESPONSE, WHICH IS SUBJECT TO NEGOTIATIONS PRIOR TO AWARD. PLEASE CONTACT THE TIPS OFFICE AT 866-839-8477 WITH QUESTIONS OR CONCERNS REGARDING VENDOR ATTRIBUTE RESPONSE DEVIATIONS. PLEASE KEEP IN MIND THAT TIPS DOES NOT PROVIDE LEGAL COUNSEL TO MEMBERS. TIPS RECOMMENDS THAT YOU CONSULT YOUR LEGAL COUNSEL WHEN EXECUTING CONTRACTS WITH OR MAKING PURCHASES FROM TIPS VENDORS.



210905 Addendum 2

Zoche, LLC

Supplier Response

Event Information

Number: 210905 Addendum 2
Title: Gym Floors, Repairs, Replacements and Services (2 Part with JOC)
Type: Request for Proposal
Issue Date: 9/2/2021
Deadline: 10/19/2021 03:00 PM (CT)
Notes: This is a 2 PART solicitation. PART 1 is for projects that are not considered construction or a public work. It includes, but is not limited to, parts, supplies, maintenance services and repairs. PART 2 Job Order Contract (JOC) is for projects considered construction or public work projects. The determination of whether or not a project requires a PART 2 JOC is the responsibility of the TIPS member entity. Vendors are encouraged to respond to BOTH PARTS 1 and 2 to meet the needs of our members, but responses to both parts is not required.

Type

Contact Information

Address: Region 8 Education Service Center
4845 US Highway 271 North
Pittsburg, TX 75686
Phone: +1 (866) 839-8477
Email: bids@tips-usa.com

Zoche, LLC Information

Contact: Michael Hunter
Address: 130 N Wilson St.
Burleson, TX 76028
Phone: (817) 246-2223
Toll Free: (855) 727-0900
Email: michael@zochellc.net
Web Address: zochellc.net

By submitting your response, you certify that you are authorized to represent and bind your company.

Michael Hunter

Signature

Submitted at 10/19/2021 12:25:56 PM

michael@zochellc.net

Email

Requested Attachments

Agreement Signature Form PART 1 ONLY

Signature Form Part 1 Signed.pdf

If you have not taken exception or deviation to the agreement language in the solicitation attributes, download the AGREEMENT SIGNATURE FORM from the "ATTACHMENTS" tab. This PDF document is a fillable form. Download the document to your computer, fill in the requested company information, print the file, SIGN the form, SCAN the completed and signed AGREEMENT SIGNATURE FORM, and upload here.

If you have taken exception to any of the agreement language and noted the exception in the deviations section of the attributes for the agreement, complete the AGREEMENT SIGNATURE FORM, but DO NOT SIGN until those deviations have been negotiated and resolved with TIPS management. Upload the unsigned form here, because this is a required document.

Vendor Agreement PART 1 ONLY

210905 Vendor Agreement - PART 1 C.pdf

The vendor must download the Vendor Agreement from the attachment tab, fill in the requested information and upload the completed agreement.

DO NOT UPLOAD encrypted or password protected files.

Vendor Agreement PART 2 ONLY

210905 Vendor Agreement JOC_PART 2 ONLY C.pdf

If proposing on Part 2, the vendor must download the Vendor Agreement from the attachment tab, fill in the requested information and upload the completed agreement.

DO NOT UPLOAD encrypted or password protected files.

Agreement Signature Form PART 2 ONLY

Signature Form Part 2 Signed.pdf

If proposing on Part 2, the vendor must download the Vendor Agreement from the attachment tab, fill in the requested information and upload the completed agreement.

DO NOT UPLOAD encrypted or password protected files.

Pricing Form 1 PART 1 ONLY

210905 Pricing Form 1 - PART 1 C.xlsx

The vendor must download the PRICING SPREADSHEET SHEET from the attachment tab, fill in the requested information and upload the completed spreadsheet.

DO NOT UPLOAD encrypted or password protected files.

Pricing Form 2 PART 1 ONLY

No response

The vendor must download the PRICING SPREADSHEET SHEET from the attachment tab, fill in the requested information and upload the completed spreadsheet.

DO NOT UPLOAD encrypted or password protected files.

Non-Prepriced Items

The Vendor may download the optional Pricing of Itemized List of RS Means Non-Prepriced Items form from the attachment tab, fill in the requested information, and upload the completed spreadsheet. DO NOT UPLOAD encrypted or password protected files.

Reference Form (PARTS 1 & 2)

210905 Reference_Form PARTS 1&2 C.xls

Valid Reference Email addresses are REQUIRED on the spreadsheet. The vendor must download the References spreadsheet from the attachment tab, fill in the requested information and upload the completed spreadsheet. DO NOT UPLOAD encrypted or password protected files.

Proposed Goods and Services

TIPS Zoche Catalog File.pdf

Please upload one or more documents or sheets describing your offerings, line cards, catalogs, links to offerings OR list links to your offerings that illustrate the catalog of proposed lines of goods and or services you carry and offer under this proposal. It does not have to be exhaustive but should, at a minimum tell us what you are offering. It could be as simple as a sheet with your link to your online catalog of goods and services.

D/M/WBE Certification OPTIONAL*No response*

D/M/WBE Certification documentation may be scanned and uploaded if you desire to claim your status as one of the identified enterprises. (Disadvantaged Business Enterprise, Minority Business Enterprise and/or Woman Business Enterprise) If vendor has more than one certification scan into one document. (PDF Format ONLY)
DO NOT UPLOAD encrypted or password protected files.

Warranty*No response*

Warranty information (if applicable) must be scanned and uploaded. (PDF Format ONLY)
DO NOT UPLOAD encrypted or password protected files.

Supplementary*No response*

Supplementary information can be scanned and uploaded. (Company information, brochures, catalogs, etc.) (PDF Format ONLY)
DO NOT UPLOAD encrypted or password protected files.

All Other Certificates*No response*

All Other Certificates (if applicable) must be scanned and uploaded. If vendor has more than one other certification scan into one document. (PDF Format ONLY)
DO NOT UPLOAD encrypted or password protected files.

Logo and Other Company Marks

Logo 1.jpg

Conflict of Interest Form CIQ- ONLY REQUIRED IF A CONFLICT EXISTS PER THE INSTRUCTIONS*No response*

ONLY REQUIRED IF A CONFLICT EXISTS PER THE INSTRUCTIONS

Conflict of Interest Form for Vendors that are required to submit the form. The Conflict of Interest Form is included in the Base documents or can be found at <https://www.tips-usa.com/assets/documents/docs/CIQ.pdf>.

Certificate of Corporate Offerer - COMPLETE ONLY IF OFFERER IS A CORPORATION*No response*

COMPLETE AND UPLOAD FORM IN ATTACHMENTS SECTION ONLY IF OFFERER IS A CORPORATION

Lobbying Report Standard Form-LLL, "disclosure Form to Report Lobbying,"*No response*

If you answered "I HAVE Lobbied per above" to attribute #66, please download and complete and upload the Standard Form-LLL, "disclosure Form to Report Lobbying," in the Response attachments section.

Confidentiality Form

Confidential Information Status Form Signed.pdf

REQUIRED CONFIDENTIALITY FORM. Complete the form according to your company requirements, make any desired attachments and upload to the appropriate section under "Response Attachments" THIS FORM DETERMINES HOW ESC8/TIPS RESPONDS TO LEGAL PUBLIC INFORMATION REQUESTS.

Bonding Capacity Letter from Surety/Insurance Company

REQUIRED IF YOU ARE PROPOSING ON PART 2 -Attach the Bonding Capacity Letter from Surety/Insurance Company. if you do not have one available at time of proposal, attached a letter stating it will be submitted when received to prove bonding capacity. No award can be made until official bonding capacity letter is received by TIPS.

Current W-9 Tax Form

2021 w9.pdf

You are required by TIPS to upload a current W-9 Internal Revenue Service (IRS) Tax Form for your entity. This form will be utilized by TIPS to properly identify your entity.

Bid Attributes

1	Yes - No Disadvantaged/Minority/Women Business Enterprise - D/M/WBE/Federal HUBZone (Required by some participating governmental entities). Vendor certifies that their firm is a D/M/WBE or HUBZone? Vendor must upload proof of certification to the "Response Attachments" D/M/WBE CERTIFICATES section. <input type="text" value="No"/>
2	Yes - No Historically Underutilized Business - HUB (Required by some participating governmental entities) Vendor certifies that their firm is a HUB as defined by the State of Texas at https://comptroller.texas.gov/purchasing/vendor/hub/ . Proof may be submitted. Vendor must upload proof of certification to the "Response Attachments" HUB CERTIFICATES section. <input type="text" value="No"/>
3	Yes - No The Vendor can provide services and/or products to all 50 US States? <input type="text" value="No"/>
4	States Served: If answer is NO to question #3, please list which states can be served. (Example: AR, OK, TX) <input type="text" value="TX, OK, AR, NM"/>
5	Company and/or Product Description: This information will appear on the TIPS website in the company profile section, if awarded a TIPS contract. (Limit 750 characters.) <input type="text" value="Distributor of indoor/outdoor sports flooring, including basketball and volleyball courts, multi use gyms, weight room, multipurpose rooms, running tracks, aerobic and yoga rooms, turf etc."/>
6	Primary Contact Name Primary Contact Name <input type="text" value="Michae Hunter"/>
7	Primary Contact Title Primary Contact Title <input type="text" value="President"/>

8	Primary Contact Email Primary Contact Email <input type="text" value="michae@zochellc.net"/>
9	Primary Contact Phone Enter 10 digit phone number. (No dashes or extensions) Example: 8668398477 <input type="text" value="8172462223"/>
10	Primary Contact Fax Enter 10 digit phone number. (No dashes or extensions) Example: 8668398477 <input type="text" value="No response"/>
11	Primary Contact Mobile Enter 10 digit phone number. (No dashes or extensions) Example: 8668398477 <input type="text" value="8178809231"/>
12	Secondary Contact Name Secondary Contact Name <input type="text" value="Dalana Middleton"/>
13	Secondary Contact Title Secondary Contact Title <input type="text" value="Office Manager"/>
14	Secondary Contact Email Secondary Contact Email <input type="text" value="dalana@zochellc.net"/>
15	Secondary Contact Phone Enter 10 digit phone number. (No dashes or extensions) Example: 8668398477 <input type="text" value="8172462223"/>
16	Secondary Contact Fax Enter 10 digit phone number. (No dashes or extensions) Example: 8668398477 <input type="text" value="No response"/>
17	Secondary Contact Mobile Enter 10 digit phone number. (No dashes or extensions) Example: 8668398477 <input type="text" value="No response"/>

1 8	Admin Fee Contact Name Admin Fee Contact Name. This person is responsible for paying the admin fee to TIPS. <input type="text" value="Elaine Wright"/>
1 9	Admin Fee Contact Email Admin Fee Contact Email <input type="text" value="elaine@zochellc.net"/>
2 0	Admin Fee Contact Phone Enter 10 digit phone number. (No dashes or extensions) Example: 8668398477 <input type="text" value="8172462223"/>
2 1	Purchase Order Contact Name Purchase Order Contact Name. This person is responsible for receiving Purchase Orders from TIPS. <input type="text" value="Dalana Middleton"/>
2 2	Purchase Order Contact Email Purchase Order Contact Email <input type="text" value="dalana@zochellc.net"/>
2 3	Purchase Order Contact Phone Enter 10 digit phone number. (No dashes or extensions) Example: 8668398477 <input type="text" value="8172462223"/>
2 4	Company Website Company Website (Format - www.company.com) <input type="text" value="www.zochellc.net"/>
2 5	Entity D/B/A's and Assumed Names Please identify all of your entity's assumed names and D/B/A's. Please note that you will be identified publicly by the legal name under which you responded to this solicitation unless you organize otherwise with TIPS after award. <input type="text" value="No response"/>
2 6	Primary Address Primary Address <input type="text" value="130 N Wilson St."/>
2 7	Primary Address City Primary Address City <input type="text" value="Burleson Texas"/>
2 8	Primary Address State Primary Address State (2 Digit Abbreviation) <input type="text" value="TX"/>

29	Primary Address Zip
	Primary Address Zip <input type="text" value="76028"/>

30	Search Words:
	Please list search words to be posted in the TIPS database about your company that TIPS website users might search. Words may be product names, manufacturers, or other words associated with the category of award. YOU MAY NOT LIST NON-CATEGORY ITEMS. (Limit 500 words) (Format: product, paper, construction, manufacturer name, etc.) <input type="text" value="Tarkett Sports, US Rubber, Dinoflex, Ergoadvantage, Safeflex, gyms, weight room, locker room, turf, wood flooring, rubber flooring, vinyl flooring, sports flooring, Gerflor, basketball, volleyball, pulastic, recycled rubber, vulcanized rubber"/>

31	Do you want TIPS Members to be able to spend Federal grant funds with you if awarded? Is it your intent to be able to sell to our members regardless of the fund source, whether it be local, state or federal?
	Most of our members receive Federal Government grants or other funding and they make up a significant portion of their budgets. The Members need to know if your company is willing to sell to them when they spend federal budget funds on their purchase. There are attributes that follow that include provisions from the federal regulations in 2 CFR part 200, etc. Your answers will determine if your award will be designated as eligible for TIPS Members to utilize federal funds with your company. Do you want TIPS Members to be able to spend Federal funds, at the Member's discretion, with you? <input type="text" value="Yes"/>

32	Yes - No
	Certification of Residency - The vendor's ultimate parent company or majority owner: (A) has its principal place of business in Texas; OR (B) employs at least 500 persons in Texas? This question is required as a data gathering function for information to our members making purchases with awarded vendors. Does not affect scoring with TIPS. <input type="text" value="Yes"/>

33	Company Residence (City)
	Vendor's principal place of business is in the city of? <input type="text" value="Burleson"/>

34	Company Residence (State)
	Vendor's principal place of business is in the state of? <input type="text" value="Texas"/>

35 Discount Offered - CAUTION READ CAREFULLY BECAUSE VENDORS FREQUENTLY MAKE MISTAKES ON THIS ATTRIBUTE QUESTION

Remember this is a MINIMUM discount percentage so, be sure the discount percentage inserted here can be applied to ANY OFFERING OF GOODS OR SERVICES THROUGH OUT THE LIFE OF THE CONTRACT

CAUTION: BE CERTAIN YOU CAN HONOR THIS MINIMUM DISCOUNT PERCENTAGE ON ANY OFFERED SERVICE OR GOOD NOW OR DURING THE LIFE OF THE CONTRACT.

What is the MINIMUM percentage discount off of any item or service you offer to TIPS Members that is in your regular catalog (as defined in the solicitation specifications document), website, store or shelf pricing or when adding new goods or services to your offerings during the life of the contract? The resulting price of any goods or services Catalog list prices after this discount is applied is a ceiling on your pricing and not a floor because, in order to be more competitive in the individual circumstance, you may offer a larger discount depending on the items or services purchased and the quantity at time of sale.
Must answer with a number between 0% and 100%.

36 MINIMUM Discount Term

Does the vendor agree to at least offer, for the life of the Agreement, the Minimum Discount Percentage off list or catalog proposed by Vendor in response to the Attribute entitled "Discount Offered - CAUTION READ CAREFULLY BECAUSE VENDORS FREQUENTLY MAKE MISTAKES ON THIS ATTRIBUTE QUESTION"? TIPS will utilize this response to satisfy the Long Term Cost scoring evaluation criteria. A "YES" answer will be awarded the maximum 10 points for this criterion out of the 100 total points and a "NO" answer is awarded 0 points.

37 Yes - No

If awarded on Part 1 of the TIPS Contract, for the duration of the Contract, Vendor agrees to provide catalog pricing, as defined in the solicitation and below, to TIPS upon request for any goods and services offered on PART 1 of the Vendor's TIPS Contract, if any.

"Catalog" means the available list of tangible personal property or services, in the most current listing, regardless of date, during the life of the contract, that takes the form of a catalog, price list, schedule, shelf price or other form that:

- A. is regularly maintained by the manufacturer or Vendor of an item; and
- B. is either published or otherwise available for inspection by a customer during the purchase process;
- C. to which the minimum discount proposed by the proposing Vendor may be applied.

38 TIPS administration fee

By submitting a proposal, I agree that all pricing submitted to TIPS shall include the participation fee, as designated in the solicitation or as otherwise agreed in writing and shall be remitted to TIPS by the Vendor or the vendor's named resellers and as agreed in the Vendor agreement. I agree that the fee shall not and will not be added by the vendor as a separate line item on a TIPS member invoice, quote, proposal or any other written communications with the TIPS member.

3 **REQUIRED FOR PART 2 JOC - PRICING OF Regular Hours Coefficient**

9 **What is your regular hours coefficient for the RS Means Price Book? (FAILURE TO RESPOND PROHIBITS PART 2 JOC EVALUATION)**

Remember that this is a ceiling price proposed. You can discount lower than your proposed contract coefficient, but not higher.

This is one of three pricing questions that are required for consideration for award on this solicitation. Please consider your answer carefully. An explanation of the TIPS scoring of pricing is included in the attachments for your information.

The below is an Example of how pricing model works (not intended to influence your proposed coefficient, you should propose a coefficient that you determine is right for your business):

To propose the exact pricing as the RS Means Unit Price Book, you would insert a 1.0 and to propose a 5% discount for the RS Means Price Book would be a .95 regular hours coefficient and so on.

4 **REQUIRED FOR PART 2 JOC - PRICING OF After Hours Coefficient**

0 **What is your after hours coefficient for the RS Means Price Book for work performed after normal working hours? (FAILURE TO RESPOND PROHIBITS PART 2 JOC EVALUATION)**

Remember that this is a ceiling price proposed. You can discount to any TIPS Member customer a lower coefficient than your proposed contract coefficient, but not higher.

This is one of three pricing questions that are required for consideration for award on this solicitation. Please consider your answer carefully. An explanation of the TIPS scoring of pricing titled "Pricing Coefficient Instruction" is included in the attachments for your information.

The below is an EXAMPLE of how the pricing model works (It is not intended to influence your proposed coefficient, you should propose a coefficient that you determine is reasonable for your business for the life of the contract): The most common after hours coefficient is time and a half of the RS Means Unit Price Book prices. To illustrate this coefficient, if your regular hours coefficient is .95, your after hours coefficient would be 1.45.

4 **REQUIRED FOR 2 PART JOC - PRICING for Markup of Non-Prepriced Items in RS Means Unit Price Book**

1 **What is your proposed Markup Percentage on materials not found in the RS Means Price Book? (FAILURE TO RESPOND PROHIBITS PART 2 JOC EVALUATION)**

If any materials being utilized for a project cannot be found in the RS Means Price Book, this question is what is the markup percentage on those materials?

When answering this question please insert the number that represents your percentage of proposed markup. Example: if you are proposing a 30 percent markup, please insert the number "30".

Remember that this is a ceiling markup. You may markup a lesser percentage to the TIPS Member customer when pricing the project, but not a greater percentage.

EXAMPLE: You need special materials that are not in the RS Means Unit Price Book for a project. You would buy the materials and mark them up to the TIPS Member customer by the percentage you propose in this question. If the materials cost you, the contractor, \$100 and you proposed a markup on this question for the material of 30 percent, then you would charge the TIPS Member customer \$130 for the materials.

4
2

Yes - No

Vendor agrees to remit to TIPS the required administration fee or, if resellers are named, guarantee the fee remittance by or for the reseller named by the vendor?

TIPS/ESC Region 8 is required by Texas Government Code § 791 to be compensated for its work and thus, failure to agree shall render your response void and it will not be considered.

4
3

Yes - No

Do you offer additional discounts to TIPS members for large order quantities or large scope of work?

4
4

Years in Business as Proposing Company

Years in business as proposing company?

4
5

Resellers:

Does the vendor have resellers that it will name under this contract?

Resellers are defined as other companies that sell your products under an agreement with you, as the awarded vendor of TIPS.

EXAMPLE: BIGmart is a reseller of ACME brand televisions. If ACME were a TIPS awarded vendor, then ACME would list BIGmart as a reseller.

(If applicable, Vendor should add all Authorized Resellers within the TIPS Vendor Portal upon award).

4
6

Right of Refusal

The proposing vendor has the right not to sell under the awarded agreement with a TIPS member at vendor's discretion unless required by law.

47 NON-COLLUSIVE BIDDING CERTIFICATE

By submission of this bid or proposal, the Bidder certifies that:

- 1) This bid or proposal has been independently arrived at without collusion with any other Bidder or with any Competitor;
- 2) This bid or proposal has not been knowingly disclosed and will not be knowingly disclosed, prior to the opening of bids, or proposals for this project, to any other Bidder, Competitor or potential competitor:
- 3) No attempt has been or will be made to induce any other person, partnership or corporation to submit or not to submit a bid or proposal;
- 4) The person signing this bid or proposal certifies that he has fully informed himself regarding the accuracy of the statements contained in this certification, and under the penalties being applicable to the Bidder as well as to the person signing in its behalf.

Not a negotiable term. Failure to agree will render your proposal non-responsive and it will not be considered.

48 CONFLICT OF INTEREST QUESTIONNAIRE - FORM CIQ -Do you have any CONFLICT OF INTEREST TO REPORT OR DISCLOSE under this statutory requirement?

Do you have any CONFLICT OF INTEREST TO REPORT OR DISCLOSE under this statutory requirement? YES or NO

If you have a conflict of interest as described in this form or the Local Government Code Chapter 176, cited therein- you are required to complete and file with TIPS. The Form CIQ is one of the attachments to this solicitation.

There is an optional upload for this form provided if you have a conflict and must file the form

49 Filing of Form CIQ

If yes (above), have you filed a form CIQ by uploading the form to this RFP as directed above?

50 Regulatory Standing

I certify to TIPS for the proposal attached that my company is in good standing with all governmental agencies Federal or state that regulate any part of our business operations. If not, please explain in the next attribute question.

51 Regulatory Standing

Regulatory Standing explanation of no answer on previous question.

Antitrust Certification Statements (Tex. Government Code § 2155.005)

By submission of this bid or proposal, the Bidder certifies that:

I affirm under penalty of perjury of the laws of the State of Texas that:

(1) I am duly authorized to execute this contract on my own behalf or on behalf of the company, corporation, firm, partnership or individual (Company) listed below;

(2) In connection with this bid, neither I nor any representative of the Company has violated any provision of the Texas Free Enterprise and Antitrust Act, Tex. Bus. & Comm. Code Chapter 15;

(3) In connection with this bid, neither I nor any representative of the Company has violated any federal antitrust law;

(4) Neither I nor any representative of the Company has directly or indirectly communicated any of the contents of this bid to a competitor of the Company or any other company, corporation, firm, partnership or individual engaged in the same line of business as the Company.

5
3

Suspension or Debarment Instructions

Instructions for Certification:

1. By answering yes to the next Attribute question below, the vendor and prospective lower tier participant is providing the certification set out herein in accordance with these instructions.
2. The certification in this clause is a material representation of fact upon which reliance was placed when this transaction was entered into. If it is later determined that the prospective lower tier participant knowingly rendered an erroneous certification in addition to other remedies available to the federal government, the department or agency with which this transaction originated may pursue available remedies, including suspension and / or debarment.
3. The prospective lower tier participant shall provide immediate written notice to the person to which this proposal is submitted if at any time the prospective lower tier participant learns that its certification was erroneous when submitted or has become erroneous by reason of changed circumstances.
4. The terms “covered transaction,” “debarred,” “suspended,” “ineligible,” “lower tier covered transaction,” “participants,” “person,” “primary covered transaction,” “principal,” “proposal” and “voluntarily excluded,” as used in this clause, have the meanings set out in the Definitions and Coverage sections of rules implementing Executive Order 12549. You may contact the person to which this proposal is submitted for assistance in obtaining a copy of those regulations.
5. The prospective lower tier participant agrees by submitting this form that, should the proposed covered transaction be entered into, it shall not knowingly enter into any lower tier covered transaction with a person who is debarred, suspended, declared ineligible or voluntarily excluded from participation in this covered transaction, unless authorized by the department or agency with which this transaction originated.
6. The prospective lower tier participant further agrees by submitting this form that it will include this clause titled “Certification Regarding Debarment, Suspension, Ineligibility and Voluntary Exclusion-Lower Tier Covered Transaction” without modification in all lower tier covered transactions and in all solicitations for lower tier covered transactions.
7. A participant in a covered transaction may rely upon a certification of a prospective participant in a lower tier covered transaction that it is not debarred, suspended, ineligible or voluntarily excluded from the covered transaction, unless it knows that the certification is erroneous. A participant may decide the method and frequency by which it determines the eligibility of its principals. Each participant may, but is not required to, check the Nonprocurement List.
8. Nothing contained in the foregoing shall be construed to require establishment of a system of records in order to render in good faith the certification required by this clause. The knowledge and information of a participant is not required to exceed that which is normally possessed by a prudent person in the ordinary course of business dealings.
9. Except for transactions authorized under paragraph 5 of these instructions, if a participant in a covered transaction knowingly enters into a lower tier covered transaction with a person who is suspended, debarred, ineligible or voluntarily excluded from participation in this transaction, in addition to other remedies available to the federal government, the department or agency with which this transaction originated may pursue available remedies, including suspension and / or debarment.

5
4

Suspension or Debarment Certification

By answering yes, you certify that no federal suspension or debarment is in place, which would preclude receiving a federally funded contract as described above.

Yes

5
5

Non-Discrimination Statement and Certification

In accordance with Federal civil rights law, all U.S. Departments, including the U.S. Department of Agriculture (USDA) civil rights regulations and policies, the USDA, its Agencies, offices, and employees, and institutions participating in or administering USDA programs are prohibited from discriminating based on race, color, national origin, religion, sex, gender identity (including gender expression), sexual orientation, disability, age, marital status, family/parental status, income derived from a public assistance program, political beliefs, or reprisal or retaliation for prior civil rights activity, in any program or activity conducted or funded by USDA (not all bases apply to all programs). Remedies and complaint filing deadlines vary by program or incident.

Persons with disabilities who require alternative means of communication for program information (e.g., Braille, large print, audiotope, American Sign Language, etc.) should contact the responsible Agency or USDA's TARGET Center at (202) 720-2600 (voice and TTY) or contact USDA through the Federal Relay Service at (800) 877-8339. Additionally, program information may be made available in languages other than English.

To file a program discrimination complaint, complete the USDA Program Discrimination Complaint Form, AD-3027, found online at How to File a Program Discrimination Complaint and at any USDA office or write a letter addressed to USDA and provide in the letter all of the information requested in the form. To request a copy of the complaint form, call (866) 632-9992. Submit your completed form or letter to USDA by: (1) mail: U.S. Department of Agriculture, Office of the Assistant Secretary for Civil Rights, 1400 Independence Avenue, SW, Washington, D.C. 20250-9410; (2) fax: (202) 690-7442; or (3) email: program.intake@usda.gov.

(Title VI of the Education Amendments of 1972; Section 504 of the Rehabilitation Act of 1973; the Age Discrimination Act of 1975; Title 7 CFR Parts 15, 15a, and 15b; the Americans with Disabilities Act; and FNS Instruction 113-1, Civil Rights Compliance and Enforcement – Nutrition Programs and Activities)

All U.S. Departments, including the USDA are equal opportunity provider, employer, and lender.

Not a negotiable term. Failure to agree will render your proposal non-responsive and it will not be considered. I certify that in the performance of a contract with TIPS or its members, that our company will conform to the foregoing anti-discrimination statement and comply with the cited and all other applicable laws and regulations.

Yes, I certify (Yes)

5
6

2 CFR PART 200 Contract Provisions Explanation

Required Federal contract provisions of Federal Regulations for Contracts for contracts with ESC Region 8 and TIPS Members:

The following provisions are required to be in place and agreed if the procurement is funded in any part with federal funds.

The ESC Region 8 and TIPS Members are the subgrantee or Subrecipient by definition. Most of the provisions are located in 2 CFR PART 200 - Appendix II to Part 200—Contract Provisions for Non-Federal Entity Contracts Under Federal Awards at 2 CFR PART 200. Others are included within 2 CFR part 200 et al.

In addition to other provisions required by the Federal agency or non-Federal entity, all contracts made by the non-Federal entity under the Federal award must contain provisions covering the following, as applicable.

5
7

2 CFR PART 200 Contracts

Contracts for more than the simplified acquisition threshold currently set at \$250,000, which is the inflation adjusted amount determined by the Civilian Agency Acquisition Council and the Defense Acquisition Regulations Council (Councils) as authorized by 41 U.S.C. 1908, must address administrative, contractual, or legal remedies in instances where contractors violate or breach contract terms, and provide for such sanctions and penalties as appropriate.

Notice: Pursuant to the above, when federal funds are expended by ESC Region 8 and TIPS Members, ESC Region 8 and TIPS Members reserves all rights and privileges under the applicable laws and regulations with respect to this procurement in the event of breach of contract by either party.

Does vendor agree?

5
8

2 CFR PART 200 Termination

Termination for cause and for convenience by the grantee or subgrantee including the manner by which it will be effected and the basis for settlement. (All contracts in excess of \$10,000)

Pursuant to the above, when federal funds are expended by ESC Region 8 and TIPS Members, ESC Region 8 and TIPS Members reserves the right to terminate any agreement in excess of \$10,000 resulting from this procurement process for cause after giving the vendor an appropriate opportunity and up to 30 days, to cure the causal breach of terms and conditions. ESC Region 8 and TIPS Members reserves the right to terminate any agreement in excess of \$10,000 resulting from this procurement process for convenience with 30 days notice in writing to the awarded vendor. The vendor would be compensated for work performed and goods procured as of the termination date if for convenience of the ESC Region 8 and TIPS Members. Any award under this procurement process is not exclusive and the ESC Region 8 and TIPS reserves the right to purchase goods and services from other vendors when it is in the best interest of the ESC Region 8 and TIPS.

Does vendor agree?

5
9

2 CFR PART 200 Clean Air Act

Clean Air Act (42 U.S.C. 7401-7671q.) and the Federal Water Pollution Control Act (33 U.S.C. 1251-1387), as amended—Contracts and subgrants of amounts in excess of \$250,000 must contain a provision that requires the non-Federal award to agree to comply with all applicable standards, orders or regulations issued pursuant to the Clean Air Act (42 U.S.C. 7401-7671q) and the Federal Water Pollution Control Act as amended (33 U.S.C. 1251-1387). Violations must be reported to the Federal awarding agency and the Regional Office of the Environmental Protection Agency (EPA).

Pursuant to the Clean Air Act, et al above, when federal funds are expended by ESC Region 8 and TIPS Members, ESC Region 8 and TIPS Members requires that the proposer certify that during the term of an award by the ESC Region 8 and TIPS Members resulting from this procurement process the vendor agrees to comply with all of the above regulations, including all of the terms listed and referenced therein.

Does vendor agree?

6
0 **2 CFR PART 200 Byrd Anti-Lobbying Amendment**

Byrd Anti-Lobbying Amendment (31 U.S.C. 1352)—Contractors that apply or bid for an award exceeding \$100,000 must file the required certification. Each tier certifies to the tier above that it will not and has not used Federal appropriated funds to pay any person or organization for influencing or attempting to influence an officer or employee of any agency, a member of Congress, officer or employee of Congress, or an employee of a member of Congress in connection with obtaining any Federal contract, grant or any other award covered by 31 U.S.C. 1352. Each tier must also disclose any lobbying with non-Federal funds that takes place in connection with obtaining any Federal award. Such disclosures are forwarded from tier to tier up to the non-Federal award.

Pursuant to the above, when federal funds are expended by ESC Region 8 and TIPS Members, ESC Region 8 and TIPS Members requires the proposer certify that during the term and during the life of any contract with ESC Region 8 and TIPS Members resulting from this procurement process the vendor certifies to the terms included or referenced herein.

Does vendor agree?

6
1 **2 CFR PART 200 Federal Rule**

Compliance with all applicable standards, orders, or requirements issued under section 306 of the Clean Air Act (42 U.S.C. 1857(h)), section 508 of the Clean Water Act (33 U.S.C. 1368), Executive Order 11738, and Environmental Protection Agency regulations (40 CFR part 15). (Contracts, subcontracts, and subgrants of amounts in excess of \$250,000)

Pursuant to the above, when federal funds are expended by ESC Region 8 and TIPS Members, ESC Region 8 and TIPS Members requires the proposer certify that in performance of the contracts, subcontracts, and subgrants of amounts in excess of \$250,000, the vendor will be in compliance with all applicable standards, orders, or requirements issued under section 306 of the Clean Air Act (42 U.S.C. 1857(h)), section 508 of the Clean Water Act (33 U.S.C. 1368), Executive Order 11738, and Environmental Protection Agency regulations (40 CFR part 15).

Does vendor certify that it is in compliance with the Clean Air Act?

6
2 **2 CFR PART 200 Procurement of Recovered Materials**

A non-Federal entity that is a state agency or agency of a political subdivision of a state and its contractors must comply with section 6002 of the Solid Waste Disposal Act, as amended by the Resource Conservation and Recovery Act. The requirements of Section 6002 include procuring only items designated in guidelines of the Environmental Protection Agency (EPA) at 40 CFR part 247 that contain the highest percentage of recovered materials practicable, consistent with maintaining a satisfactory level of competition, where the purchase price of the item exceeds \$10,000 or the value of the quantity acquired during the preceding fiscal year exceeded \$10,000; procuring solid waste management services in a manner that maximizes energy and resource recovery; and establishing an affirmative procurement program for procurement of recovered materials identified in the EPA guidelines.

Does vendor certify that it is in compliance with the Solid Waste Disposal Act as described above?

6 3 2 CFR PART 200 Rights to Inventions

If the Federal award meets the definition of “funding agreement” under 37 CFR §401.2 (a) and the recipient or subrecipient wishes to enter into a contract with a small business firm or nonprofit organization regarding the substitution of parties, assignment or performance of experimental, developmental, or research work under that “funding agreement,” the recipient or subrecipient must comply with the requirements of 37 CFR Part 401, “Rights to Inventions Made by Nonprofit Organizations and Small Business Firms Under Government Grants, Contracts and Cooperative Agreements,” and any implementing regulations issued by the awarding agency.

Pursuant to the above, when the foregoing applies to ESC Region 8 and TIPS Members, Vendor certifies that during the term of an award resulting from this procurement process, Vendor agrees to comply with all applicable requirements as referenced in the Federal rule above.

Does vendor agree?

6 4 2 CFR PART 200 Domestic Preferences for Procurements

As appropriate and to the extent consistent with law, the non-Federal entity should, to the greatest extent practicable under a Federal award, provide a preference for the purchase, acquisition, or use of goods, products, or materials produced in the United States (including but not limited to iron, aluminum, steel, cement, and other manufactured products). The requirements of this section must be included in all subawards including all contracts and purchase orders for work or products under this award. For purposes of 2 CFR Part 200.322, “Produced in the United States” means, for iron and steel products, that all manufacturing processes, from the initial melting stage through the application of coatings, occurred in the United States. Moreover, for purposes of 2 CFR Part 200.322, “Manufactured products” means items and construction materials composed in whole or in part of non-ferrous metals such as aluminum, plastics and polymer-based products such as polyvinyl chloride pipe, aggregates such as concrete, class, including optical fiber, and lumber.

Pursuant to the above, when federal funds are expended by ESC Region 8 and TIPS Members, Vendor certifies that to the greatest extent practicable Vendor will provide a preference for the purchase, acquisition, or use of goods, products, or materials produced in the United States (including but not limited to iron, aluminum, steel, cement, and other manufactured products).

Does vendor agree?

6 5 2 CFR PART 200 Ban on Foreign Telecommunications

Federal grant funds may not be used to purchase equipment, services, or systems that use “covered telecommunications” equipment or services as a substantial or essential component of any system, or as critical technology as part of any system. “Covered telecommunications” means purchases from Huawei Technologies Company or ZTE Corporation (or any subsidiary or affiliate of such entities), and video surveillance and telecommunications equipment produced by Hytera Communications Corporation, Hangzhou Hikvision Digital Technology Company, or Dahua Technology Company (or any subsidiary or affiliate of such entities).

Pursuant to the above, when federal funds are expended by ESC Region 8 and TIPS Members, Vendor certifies that Vendor will not purchase equipment, services, or systems that use “covered telecommunications”, as defined by 2 CFR §200.216 equipment or services as a substantial or essential component of any system, or as critical technology as part of any system.

Does vendor agree?

6 2 CFR PART 200 Equal Employment Opportunity

Except as otherwise provided under 41 CFR Part 60, all contracts that meet the definition of “federally assisted construction contract” in 41 CFR Part 60-1.3 must include the equal opportunity clause provided under 41 CFR 60-1.4(b), in accordance with Executive Order 11246, “Equal Employment Opportunity” (30 FR 12319, 12935, 3 CFR Part, 1964-1965 Comp., p. 339), as amended by Executive Order 11375, “Amending Executive Order 11246 Relating to Equal Employment Opportunity,” and implementing regulations at 41 CFR part 60, “Office of Federal Contract Compliance Programs, Equal Employment Opportunity, Department of Labor.”

Pursuant to the above, when federal funds are expended by ESC Region 8 and TIPS Members on any federally assisted construction contract, the equal opportunity clause is incorporated by reference herein.

Does vendor agree?

6 2 CFR PART 200 Contract Work Hours and Safety Standards Act (40 U.S.C. 3701-3708)

[Applicable ONLY to contracts in excess of \$100,000 involving mechanics or laborers.] Contract Work Hours and Safety Standards Act (40 U.S.C. 3701-3708). Where applicable, all contracts awarded by the non-Federal entity in excess of \$100,000 that involve the employment of mechanics or laborers must include a provision for compliance with 40 U.S.C. 3702 and 3704, as supplemented by Department of Labor regulations (29 CFR Part 5). Under 40 U.S.C. 3702 of the Act, each contractor must be required to compute the wages of every mechanic and laborer on the basis of a standard work week of 40 hours. Work in excess of the standard work week is permissible provided that the worker is compensated at a rate of not less than one and a half times the basic rate of pay for all hours worked in excess of 40 hours in the work week. The requirements of 40 U.S.C. 3704 are applicable to construction work and provide that no laborer or mechanic must be required to work in surroundings or under working conditions which are unsanitary, hazardous or dangerous. These requirements do not apply to the purchases of supplies or materials or articles ordinarily available on the open market, or contracts for transportation or transmission of intelligence.

Pursuant to the above, when federal funds are expended by ESC Region 8 and TIPS Members on qualifying contracts, Vendor certifies that Vendor will be in compliance with all applicable provisions of the Contract Work Hours and Safety Standards Act during the term of an award for all contracts by the District resulting from this procurement process.

Does vendor agree?

6
8

Certification Regarding Lobbying

Applicable to Grants, Subgrants, Cooperative Agreements, and Contracts Exceeding \$100,000 in Federal Funds

Submission of this certification is a prerequisite for making or entering into this transaction and is imposed by section 1352, Title 31, U.S. Code. This certification is a material representation of fact upon which reliance was placed when this transaction was made or entered into. Any person who fails to file the required certification shall be subject to a civil penalty of not less than \$10,000 and not more than \$100,000 for each such failure.

The undersigned certifies, to the best of his or her knowledge and belief, that:

(1) No Federal appropriated funds have been paid or will be paid by or on behalf of the undersigned, to any person for influencing or attempting to influence an officer or employee of any agency, a Member of Congress, an officer or employee of congress, or an employee of a Member of Congress in connection with the awarding of a Federal contract, the making of a Federal grant, the making of a Federal loan, the entering into a cooperative agreement, and the extension, continuation, renewal, amendment, or modification of a Federal contract, grant, loan, or cooperative agreement.

(2) If any funds other than Federal appropriated funds have been paid or will be paid to any person for influencing or attempting to influence an officer or employee of any agency, a Member of Congress, an officer or employee of congress, or an employee of a Member of Congress in connection with this Federal grant or cooperative agreement, the undersigned shall complete and submit Standard Form-LLL, "disclosure Form to Report Lobbying," in accordance with its instructions.

(3) The undersigned shall require that the language of this certification be included in the award documents for all covered subawards exceeding \$100,000 in Federal funds at all appropriate tiers and that all subrecipients shall certify and disclose accordingly.

6
9

Lobbying Report Standard Form-LLL, "disclosure Form to Report Lobbying,"

ONLY IF you answered "I HAVE Lobbied per above" to attribute above titled "[Certification Regarding Lobbying](#)", please download and complete and upload the Standard Form-LLL, "disclosure Form to Report Lobbying," in the Response attachments section.

7
0

Subcontracting with small and minority businesses, women's business enterprises, and labor surplus area firms.

Do you ever anticipate the possibility of subcontracting any of your work under this award if you are successful?

IF NO, DO NOT ANSWER THE NEXT ATTRIBUTE QUESTION. . IF YES, and ONLY IF YES, you must answer the next question YES if you want a TIPS Member to be authorized to spend Federal Grant Funds for Procurement.

7
1

ONLY IF YES TO THE PREVIOUS QUESTION OR if you ever do subcontract any part of your performance under the TIPS Agreement, do you agree to comply with the following federal requirements?

ONLY IF YES TO THE ABOVE QUESTIONS OR if you ever do subcontract any part of your performance under the TIPS Agreement,

do you agree to comply with the following federal requirements?

Federal Regulation 2 CFR §200.321 Contracting with small and minority businesses, women's business enterprises, and labor surplus area firms. (a)The non-Federal entity must take all necessary affirmative steps to assure that minority businesses, women's business enterprises, and labor surplus area firms are used when possible.

(b) Affirmative steps must include:(1) Placing qualified small and minority businesses and women's business enterprises on solicitation lists;

(2) Assuring that small and minority businesses, and women's business enterprises are solicited whenever they are potential sources;

(3) Dividing total requirements, when economically feasible, into smaller tasks or quantities to permit maximum participation by small and minority businesses, and women's business enterprises;

(4) Establishing delivery schedules, where the requirement permits, which encourage participation by small and minority businesses, and women's business enterprises;

(5) Using the services and assistance, as appropriate, of such organizations as the Small Business Administration and the Minority Business Development Agency of the Department of Commerce ; and

(6) Requiring the prime contractor, if subcontracts are to be let, to take the affirmative steps listed in paragraphs(1) through (5) of this section.

No response

7
2

If proposing on PART 2, Davis-Bacon Act compliance.

IF proposing on PART 2, Texas Statute requires compliance with Davis-Bacon Act, as amended (40 U.S.C. 3141-3148). When required by Federal program legislation, all prime construction contracts in excess of \$2,000 awarded by non-Federal entities must include a provision for compliance with the Davis-Bacon Act (40 U.S.C. 3141-3144, and 3146-3148) as supplemented by Department of Labor regulations (29 CFR Part S, "Labor Standards Provisions Applicable to Contracts Covering Federally Financed and Assisted Construction"). In accordance with the statute, contractors must be required to pay wages to laborers and mechanics at a rate not less than the prevailing wages specified in a wage determination made by the Secretary of Labor. In addition, contractors must be required to pay wages not less than once a week. The non-Federal entity must place a copy of the current prevailing wage determination issued by the Department of Labor in each solicitation. The decision to award a contract or subcontract must be conditioned upon the acceptance of the wage determination. The non-Federal entity must report all suspected or reported violations to the Federal awarding agency. The contracts must also include a provision for compliance with the Copeland "Anti-Kickback" Act {40 U.S.C. 314S), as supplemented by Department of Labor regulations (29 CFR Part 3, "Contractors and Subcontractors on Public Building or Public Work Financed in Whole or in Part by Loans or Grants from the United States"). The Act provides that each contractor or subrecipient must be prohibited from inducing, by any means, any person employed in the construction, completion, or repair of public work, to give up any part of the compensation to which he or she is otherwise entitled. The non-Federal entity must report all suspected or reported violations to the Federal awarding agency.

BY SUBMITTING A PROPOSAL FOR PART 2 OF THIS SOLICITATION, the Vendor agrees, AS REQUIRED BY LAW, to comply with the Davis Bacon Act, IF APPLICABLE and if proposing on PART 2 of this solicitation.

**7
3** **Contract Work Hours and Safety Standards Act (40 U.S.C. 3701-3708)**

Where applicable, all contracts awarded by the non-Federal entity in excess of \$100,000 that involve the employment of mechanics or laborers must include a provision for compliance with 40 U.S.C. 3702 and 3704, as supplemented by Department of Labor regulations (29 CFR Part 5). Under 40 U.S.C. 3702 of the Act, each contractor must be required to compute the wages of every mechanic and laborer on the basis of a standard work week of 40 hours. Work in excess of the standard work week is permissible provided that the worker is compensated at a rate of not less than one and a half times the basic rate of pay for all hours worked in excess of 40 hours in the work week. The requirements of 40 U.S.C. 3704 are applicable to construction work and provide that no laborer or mechanic must be required to work in surroundings or under working conditions which are unsanitary, hazardous or dangerous. These requirements do not apply to the purchases of supplies or materials or articles ordinarily available on the open market, or contracts for transportation or transmission of intelligence.

By submitting a proposal to PART 2 of this solicitation and IF the customer is utilizing federal funds as described above, the Vendor agrees to comply with the Contract Work Hours and Safety Standards Act (40 U.S.C. 3701-3708).

**7
4** **Indemnification**

The ESC Region 8 and TIPS is a Texas Political Subdivision and a local governmental entity; therefore, is prohibited from indemnifying third parties pursuant to the Texas Constitution (Article 3, Section 52) except as specifically provided by law or as ordered by a court of competent jurisdiction. A provision in a contract to indemnify or hold a party harmless is a promise to pay for any expenses the indemnified party incurs, if a specified event occurs, such as breaching the terms of the contract or negligently performing duties under the contract. Article III, Section 49 of the Texas Constitution states that "no debt shall be created by or on behalf of the State ... " The Attorney General has counseled that a contractually imposed obligation of indemnity creates a "debt" in the constitutional sense. Tex. Att'y Gen. Op. No. MW-475 (1982). Contract clauses which require the System or institutions to indemnify must be deleted or qualified with "to the extent permitted by the Constitution and Laws of the State of Texas." Liquidated damages, attorney's fees, waiver of vendor's liability, and waiver of statutes of limitations clauses should also be deleted or qualified with "to the extent permitted by the Constitution and laws of State of Texas."

Do you agree to these terms?

Yes, I Agree (Yes)

**7
5** **Remedies**

The parties shall be entitled to exercise any right or remedy available to it either at law or in equity, subject to the choice of law, venue and service of process clauses limitations agreed herein. Nothing in this agreement shall commit the TIPS to an arbitration resolution of any disagreement under any circumstances. Any Claim arising out of or related to the Contract, except for those specifically waived under the terms of the Contract, may, after denial of the Board of Directors, be subject to mediation at the request of either party. Any issues not resolved hereunder MAY be referred to non-binding mediation to be conducted by a mutually agreed upon mediator as a prerequisite to the filing of any lawsuit over such issue(s). The parties shall share the mediator's fee and any associated filing fee equally. Mediation shall be held in Camp or Titus County, Texas. Agreements reached in mediation shall be reduced to writing, and will be subject to the approval by the District's Board of Directors, signed by the Parties if approved by the Board of Directors, and, if signed, shall thereafter be enforceable as provided by the laws of the State of Texas.

Do you agree to these terms?

**7
6** **Remedies Explanation of No Answer**

7
7 **Choice of Law**

The agreement between the Vendor and TIPS/ESC Region 8 and any addenda or other additions resulting from this procurement process, however described, shall be governed by, construed and enforced in accordance with the laws of the State of Texas, regardless of any conflict of laws principles.
THIS DOES NOT APPLY to a vendor's agreement entered into with a TIPS Member, as the Member may be located outside Texas.

Do you agree to these terms?

7
8 **Venue, Jurisdiction and Service of Process**

Any proceeding, involving Region 8 ESC or TIPS, arising out of or relating to this procurement process or any contract issued by TIPS resulting from or any contemplated transaction shall be brought in a court of competent jurisdiction in Camp County, Texas and each of the parties irrevocably submits to the exclusive jurisdiction of said court in any such proceeding, waives any objection it may now or hereafter have to venue or to convenience of forum, agrees that all claims in respect of the Proceeding shall be heard and determined only in any such court, and agrees not to bring any proceeding arising out of or relating to this procurement process or any contract resulting from or any contemplated transaction in any other court. The parties agree that either or both of them may file a copy of this paragraph with any court as written evidence of the knowing, voluntary and freely bargained for agreement between the parties irrevocably to waive any objections to venue or to convenience of forum. Process in any Proceeding referred to in the first sentence of this Section may be served on any party anywhere in the world. Any dispute resolution process other than litigation shall have venue in Camp County or Titus County Texas.

Do you agree to these terms?

7
9 **Alternative Dispute Resolution Explanation of No Answer**

8
0 **Infringement(s)**

The successful vendor will be expected to indemnify and hold harmless the TIPS and its employees, officers, agents, representatives, contractors, assignees and designees from any and all third party claims and judgments involving infringement of patent, copyright, trade secrets, trade or service marks, and any other intellectual or intangible property rights attributed to or claims based on the Vendor's proposal or Vendor's performance of contracts awarded and approved.

Do you agree to these terms?

8
1 **Infringement(s) Explanation of No Answer**

8
2 **Acts or Omissions**

The successful vendor will be expected to indemnify and hold harmless the TIPS, its officers, employees, agents, representatives, contractors, assignees and designees from and against any and all liability, actions, claims, demands or suits, and all related costs, attorney's fees and expenses arising out of, or resulting from any acts or omissions of the vendor or its agents, employees, subcontractors, or suppliers in the execution or performance of any agreements ultimately made by TIPS and the vendor.

Do you agree to these terms?

8
3 **Acts or Omissions Explanation of No Answer**

No response

8
4 **Contract Governance**

Any contract made or entered into by the TIPS is subject to and is to be governed by Section 271.151 et seq, Tex Loc Gov't Code. Otherwise, TIPS does not waive its governmental immunities from suit or liability except to the extent expressly waived by other applicable laws in clear and unambiguous language.

Yes, I Agree (Yes)

8
5 **Payment Terms and Funding Out Clause**

Payment Terms:

TIPS or TIPS members shall not be liable for interest or late payment fees on past due balances at a rate higher than permitted by the laws or regulations of the jurisdiction of the TIPS Member.

Funding Out Clause:

Vendor agrees to abide by the laws and regulations, including Texas Local Government Code § 271.903, or any statutory or regulatory limitations of the jurisdiction of any TIPS Member which governs contracts entered into by the Vendor and TIPS or a TIPS Member that requires all contracts approved by TIPS or a TIPS Member are subject to the budgeting and appropriation of currently available funds by the entity or its governing body.

See statute(s) for specifics or consult your legal counsel.

Not a negotiable term. Failure to agree will render your proposal non-responsive and it will not be considered.

Do you agree to these terms?

Yes, I Agree (Yes)

8 Insurance and Fingerprint Requirements Information

6 Insurance

If applicable and your staff will be on TIPS member premises for delivery, training or installation etc. and/or with an automobile, you must carry automobile insurance as required by law. You may be asked to provide proof of insurance.

Fingerprint

It is possible that a vendor may be subject to Chapter 22 of the Texas Education Code. The Texas Education Code, Chapter 22, Section 22.0834 & 22.08341. Statutory language may be found at: <http://www.statutes.legis.state.tx.us/>

If the vendor has staff that meet both of these criterion:

- (1) will have continuing duties related to the contracted services; and
- (2) has or will have direct contact with students

Then you have "covered" employees for purposes of completing the attached form.

TIPS recommends all vendors consult their legal counsel for guidance in compliance with this law. If you have questions on how to comply, see below. If you have questions on compliance with this code section, contact the Texas Department of Public Safety Non-Criminal Justice Unit, Access and Dissemination Bureau, FAST-FACT at NCJU@txdps.state.tx.us and you should send an email identifying you as a contractor to a Texas Independent School District or ESC Region 8 and TIPS. Texas DPS phone number is (512) 424-2474.

See form in the next attribute to complete entitled:
Texas Education Code Chapter 22 Contractor Certification for Contractor Employees

Texas Education Code Chapter 22 Contractor Certification for Contractor Employees

Introduction: Texas Education Code Chapter 22 requires entities that contract with school districts to provide services to obtain criminal history record information regarding covered employees. Contractors must certify to the district that they have complied. Covered employees with disqualifying criminal histories are prohibited from serving at a school district.

Definitions: Covered employees: Employees of a contractor or subcontractor who have or will have continuing duties related to the service to be performed at the District and have or will have direct contact with students. The District will be the final arbiter of what constitutes direct contact with students. Disqualifying criminal history: Any conviction or other criminal history information designated by the District, or one of the following offenses, if at the time of the offense, the victim was under 18 or enrolled in a public school:

(a) a felony offense under Title 5, Texas Penal Code; (b) an offense for which a defendant is required to register as a sex offender under Chapter 62, Texas Code of Criminal Procedure; or (c) an equivalent offense under federal law or the laws of another state.

I certify that:

NONE (Section A) of the employees of Contractor and any subcontractors are covered employees, as defined above. If this box is checked, I further certify that Contractor has taken precautions or imposed conditions to ensure that the employees of Contractor and any subcontractor will not become covered employees. Contractor will maintain these precautions or conditions throughout the time the contracted services are provided.

OR

SOME (Section B) or all of the employees of Contractor and any subcontractor are covered employees. If this box is checked, I further certify that:

(1) Contractor has obtained all required criminal history record information regarding its covered employees. None of the covered employees has a disqualifying criminal history.

(2) If Contractor receives information that a covered employee subsequently has a reported criminal history, Contractor will immediately remove the covered employee from contract duties and notify the District in writing within 3 business days.

(3) Upon request, Contractor will provide the District with the name and any other requested information of covered employees so that the District may obtain criminal history record information on the covered employees.

(4) If the District objects to the assignment of a covered employee on the basis of the covered employee's criminal history record information, Contractor agrees to discontinue using that covered employee to provide services at the District.

Noncompliance or misrepresentation regarding this certification may be grounds for contract termination.

None

8 Texas Business and Commerce Code § 272 Requirements as of 9-1-2017

SB 807 prohibits construction contracts to have provisions requiring the contract to be subject to the laws of another state, to be required to litigate the contract in another state, or to require arbitration in another state. A contract with such provisions is voidable. Under this new statute, a "construction contract" includes contracts, subcontracts, or agreements with (among others) architects, engineers, contractors, construction managers, equipment lessors, or materials suppliers. "Construction contracts" are for the design, construction, alteration, renovation, remodeling, or repair of any building or improvement to real property, or for furnishing materials or equipment for the project. The term also includes moving, demolition, or excavation. BY RESPONDING TO THIS SOLICITATION, AND WHEN APPLICABLE, THE PROPOSER AGREES TO COMPLY WITH THE TEXAS BUSINESS AND COMMERCE CODE § 272 WHEN EXECUTING CONTRACTS WITH TIPS MEMBERS THAT ARE TEXAS GOVERNMENT ENTITIES.

8 Texas Government Code 2270 & 2270 Verification Form

Texas Government Code 2270 & 2271 Verification Form
If (a) Vendor is not a sole proprietorship; (b) Vendor has ten (10) or more full-time employees; and (c) this Agreement has a value of \$100,000 or more, the following certification shall apply; otherwise, this certification is not required. Pursuant to Chapter 2271 of the Texas Government Code, the Vendor hereby certifies and verifies that neither the Vendor, nor any affiliate, subsidiary, or parent company of the Vendor, if any (the "Vendor Companies"), boycotts Israel, and the Vendor agrees that the Vendor and Vendor Companies will not boycott Israel during the term of this Agreement. For purposes of this Agreement, the term "boycott" shall mean and include refusing to deal with, terminating business activities with, or otherwise taking any action that is intended to penalize, inflict economic harm on, or limit commercial relations with Israel, or with a person or entity doing business in Israel or in an Israeli-controlled territory, but does not include an action made for ordinary business purposes.
Our entity further certifies that it is is not listed on and we do not do business with companies prohibited by Texas Government Code 2270 or that are on the Texas Comptroller of Public Accounts list of Designated Foreign Terrorists Organizations per Texas Gov't Code 2270.0153 found at <https://comptroller.texas.gov/purchasing/docs/foreign-terrorist.pdf>
I swear and affirm that the above is true and correct.

YES

9 Logos and other company marks

Please upload your company logo to be added to your individual profile page on the TIPS website. If any particular specifications are required for use of your company logo, please upload that information under the "Logo and Other Company Marks" section under the "Response Attachment" tab. Preferred Logo Format: 300 x 225 px - .png, .eps, .jpeg preferred

Potential uses of company logo:

- * Your Vendor Profile Page of TIPS website
- * Potentially on TIPS website scroll bar for Top Performing Vendors
- * TIPS Quarterly eNewsletter sent to TIPS Members
- * Co-branding Flyers and or email blasts to our TIPS Members (Permission and approval will be obtained before publishing)

9 1	Solicitation Deviation/Compliance Does the vendor agree with the General Conditions Standard Terms and Conditions or Item Specifications listed in this proposal invitation? <input type="text" value="Yes"/>
----------------------	--

9 2	Solicitation Exceptions/Deviations Explanation If the bidder intends to deviate from the General Conditions Standard Terms and Conditions or Item Specifications listed in this proposal invitation, all such deviations must be listed on this attribute, with complete and detailed conditions and information included or attached. TIPS will consider any deviations in its proposal award decisions, and TIPS reserves the right to accept or reject any bid based upon any deviations indicated below or in any attachments or inclusions. In the absence of any deviation entry on this attribute, the proposer assures TIPS of their full compliance with the Standard Terms and Conditions, Item Specifications, and all other information contained in this Solicitation. <input type="text" value="No response"/>
----------------------	---

9 3	Agreement Deviation/Compliance Does the vendor agree with the language in the Vendor Agreement? <input type="text" value="Yes"/>
----------------------	---

9 4	Agreement Exceptions/Deviations Explanation If the proposing Vendor desires to deviate from the Vendor Agreement language, all such deviations must be listed on this attribute, with complete and detailed conditions and information included. TIPS will consider any deviations in its proposal award decisions, and TIPS reserves the right to accept or reject any proposal based upon any deviations indicated below. In the absence of any deviation entry on this attribute, the proposer assures TIPS of their full compliance with the Vendor Agreement. <input type="text" value="No response"/>
----------------------	--

9 5	Felony Conviction Notice Texas Education Code, Section 44.034, Notification of Criminal History, Subsection (a), states "a person or business entity that enters into a contract with a school district must give advance notice to the district if the person or an owner or operator of the business entity has been convicted of a felony. The notice must include a general description of the conduct resulting in the conviction of a felony." Subsection (b) states "a school district may terminate a contract with a person or business entity if the district determines that the person or business entity failed to give notice as required by Subsection (a) or misrepresented the conduct resulting in the conviction. The district must compensate the person or business entity for services performed before the termination of the contract." (c) This section does not apply to a publicly held corporation. The person completing this proposal certifies that they are authorized to provide the answer to this question. Select A., B. or C. A. My firm is a publicly held corporation; therefore, this reporting requirement is not applicable. OR B. My firm is not owned nor operated by anyone who has been convicted of a felony, OR C. My firm is owned or operated by the following individual(s) who has/have been convicted of a felony. (if you answer C below, you are required to provide information in the next attribute. <input type="text" value="B. Firm not owned nor operated by felon; per above"/>
----------------------	---

96 **If you answered C. My Firm is owned or operated by a felon to the previous question, you are REQUIRED TO ANSWER THE FOLLOWING QUESTIONS.**

If you answered C. My Firm is owned or operated by a felon to the previous question, you must provide the following information.

1. Name of Felon(s)
2. The named person's role in the firm, and
3. Details of Conviction(s).

97 **Required Confidentiality Claim Form**

Required Confidentiality Claim Form

This completed form is required by TIPS. By submitting a response to this solicitation you agree to download from the "Attachments" section, complete according to the instructions on the form, then upload the completed form, with any confidential attachments, if applicable, to the "Response Attachments" section titled "Confidentiality Form" in order to provide to TIPS the completed form titled, "CONFIDENTIALITY CLAIM FORM". **THIS REQUIRED PROCESS IS THE ONLY WAY TO DEEM PROPOSAL DOCUMENTATION CONFIDENTIAL ANY OTHER CONFIDENTIAL DESIGNATION WILL BE DISREGARDED UNLESS THE DOCUMENT IS IDENTIFIED BY AND ATTACHED TO THE REQUIRED FORM.** By completing this process, you provide us with the information we require to comply with the open record laws of the State of Texas as they may apply to your proposal submission. If you do not provide the form with your proposal, an award will not be made if your proposal is qualified for an award, until TIPS has an accurate, completed form from you.

Read the form carefully before completing and if you have any questions, email bids@tips-usa.com.

98 **Choice of Law clauses for TIPS Members**

If the vendor is awarded a contract with TIPS under this solicitation, the vendor agrees to make any Choice of Law clauses in any contract or agreement entered into between the awarded vendor and with a TIPS member entity to read as follows: "Choice of law shall be the laws of the state where the customer resides" or words to that effect.

99 **Venue of dispute resolution with a TIPS Member**

In the event of litigation or use of any dispute resolution model when resolving disputes with a TIPS member entity as a result of a transaction between the vendor and TIPS or the TIPS member entity, the Venue for any litigation or other agreed upon model shall be in the state and county where the customer resides unless otherwise agreed by the parties at the time the dispute resolution model is decided by the parties.

100 **Indemnity Limitation with TIPS Members**

Texas and other states restrict by law or state Constitution the ability of a governmental entity to indemnify others. TIPS requires that any contract entered into between a vendor and TIPS or a TIPS Member as a result of an award under this Solicitation limit the requirement that the Customer indemnify the Vendor by either eliminating any such indemnity requirement clauses in any agreements, contracts or other binding documents **OR** by prefacing all indemnity clauses required of TIPS or the TIPS Member entity with the following: "To the extent permitted by the laws or the Constitution of the state where the customer resides, ".

Agreement is a required condition to award of a contract resulting from this Solicitation.

1
0
1

Arbitration Clauses

Except for certain circumstances, TIPS forbids a mandatory arbitration clause in any contract or agreement entered into between the awarded vendor with TIPS or a TIPS member entity. Does the vendor agree to exclude any arbitration requirement in any contracts or agreement entered into between TIPS or a TIPS member entity through an awarded contract with TIPS?

Agreement is a required condition to award of a contract resulting from this Solicitation.

1
0
2

Upload of Current W-9 Required

Please note that you are required by TIPS to upload a current W-9 Internal Revenue Service (IRS) Tax Form for your entity. This form will be utilized by TIPS to properly identify your entity.

1
0
3

CERTIFICATION REGARDING BOYCOTTING CERTAIN ENERGY COMPANIES (Texas law as of September 1, 2021)

By submitting a proposal to this Solicitation, you certify that you agree, when it is applicable, to the following required by Texas law as of September 1, 2021:

If (a) company is not a sole proprietorship; (b) company has ten (10) or more full-time employees; and (c) this contract has a value of \$100,000 or more that is to be paid wholly or partly from public funds, the following certification shall apply; otherwise, this certification is not required. Pursuant to Tex. Gov't Code Ch. 2274 of SB 13 (87th session), the company hereby certifies and verifies that the company, or any wholly owned subsidiary, majority-owned subsidiary, parent company, or affiliate of these entities or business associations, if any, does not boycott energy companies and will not boycott energy companies during the term of the contract. For purposes of this contract, the term "company" shall mean an organization, association, corporation, partnership, joint venture, limited partnership, limited liability partnership, or limited liability company, that exists to make a profit. The term "boycott energy company" shall mean "without an ordinary business purpose, refusing to deal with, terminating business activities with, or otherwise taking any action intended to penalize, inflict economic harm on, or limit commercial relations with a company because the company (a) engages in the exploration, production, utilization, transportation, sale, or manufacturing of fossil fuel-based energy and does not commit or pledge to meet environmental standards beyond applicable federal and state law, or (b) does business with a company described by paragraph (a)." See Tex. Gov't Code § 809.001(1).

1
0
4

CERTIFICATION PROHIBITING DISCRIMINATION AGAINST FIREARM AND AMMUNITION INDUSTRIES (Texas law as of September 1, 2021)

By submitting a proposal to this Solicitation, you certify that you agree, when it is applicable, to the following required by Texas law as of September 1, 2021:

If (a) company is not a sole proprietorship; (b) company has at least ten (10) full-time employees; (c) this contract has a value of at least \$100,000 that is paid wholly or partly from public funds; (d) the contract is not excepted under Tex. Gov't Code § 2274.003 of SB 19 (87th leg.); and (e) governmental entity has determined that company is not a sole-source provider or governmental entity has not received any bids from a company that is able to provide this written verification, the following certification shall apply; otherwise, this certification is not required.

Pursuant to Tex. Gov't Code Ch. 2274 of SB 19 (87th session), the company hereby certifies and verifies that the company, or association, corporation, partnership, joint venture, limited partnership, limited liability partnership, or limited liability company, including a wholly owned subsidiary, majority-owned subsidiary parent company, or affiliate of these entities or associations, that exists to make a profit, does not have a practice, policy, guidance, or directive that discriminates against a firearm entity or firearm trade association and will not discriminate during the term of this contract against a firearm entity or firearm trade association. For purposes of this contract, "discriminate against a firearm entity or firearm trade association" shall mean, with respect to the entity or association, to: "(1) refuse to engage in the trade of any goods or services with the entity or association based solely on its status as a firearm entity or firearm trade association; (2) refrain from continuing an existing business relationship with the entity or association based solely on its status as a firearm entity or firearm trade association; or (3) terminate an existing business relationship with the entity or association based solely on its status as a firearm entity or firearm trade association. See Tex. Gov't Code § 2274.001(3) of SB 19. "Discrimination against a firearm entity or firearm trade association" does not include: "(1) the established policies of a merchant, retail seller, or platform that restrict or prohibit the listing or selling of ammunition, firearms, or firearm accessories; and (2) a company's refusal to engage in the trade of any goods or services, decision to refrain from continuing an existing business relationship, or decision to terminate an existing business relationship to comply with federal, state, or local law, policy, or regulations or a directive by a regulatory agency, or for any traditional business reason that is specific to the customer or potential customer and not based solely on an entity's or association's status as a firearm entity or firearm trade association." See Tex. Gov't Code § 2274.001(3) of SB 19.

1
0
5

CERTIFICATION REGARDING CERTAIN FOREIGN-OWNED COMPANIES IN CONNECTION WITH CRITICAL INFRASTRUCTURE (Texas law as of September 1, 2021)

By submitting a proposal to this Solicitation, you certify that you agree, when it is applicable, to the following required by Texas law as of September 1, 2021:

If (a) company is not a sole proprietorship; (b) company has at least ten (10) full-time employees; (c) this contract has a value of at least \$100,000 that is paid wholly or partly from public funds; (d) the contract is not excepted under Tex. Gov't Code § 2274.003 of SB 19 (87th leg.); and (e) governmental entity has determined that company is not a sole-source provider or governmental entity has not received any bids from a company that is able to provide this written verification, the following certification shall apply; otherwise, this certification is not required.

Pursuant to Tex. Gov't Code Ch. 2274 of SB 19 (87th session), the company hereby certifies and verifies that the company, or association, corporation, partnership, joint venture, limited partnership, limited liability partnership, or limited liability company, including a wholly owned subsidiary, majority-owned subsidiary parent company, or affiliate of these entities or associations, that exists to make a profit, does not have a practice, policy, guidance, or directive that discriminates against a firearm entity or firearm trade association and will not discriminate during the term of this contract against a firearm entity or firearm trade association. For purposes of this contract, "discriminate against a firearm entity or firearm trade association" shall mean, with respect to the entity or association, to: "(1) refuse to engage in the trade of any goods or services with the entity or association based solely on its status as a firearm entity or firearm trade association; (2) refrain from continuing an existing business relationship with the entity or association based solely on its status as a firearm entity or firearm trade association; or (3) terminate an existing business relationship with the entity or association based solely on its status as a firearm entity or firearm trade association. See Tex. Gov't Code § 2274.001(3) of SB 19. "Discrimination against a firearm entity or firearm trade association" does not include: "(1) the established policies of a merchant, retail seller, or platform that restrict or prohibit the listing or selling of ammunition, firearms, or firearm accessories; and (2) a company's refusal to engage in the trade of any goods or services, decision to refrain from continuing an existing business relationship, or decision to terminate an existing business relationship to comply with federal, state, or local law, policy, or regulations or a directive by a regulatory agency, or for any traditional business reason that is specific to the customer or potential customer and not based solely on an entity's or association's status as a firearm entity or firearm trade association." See Tex. Gov't Code § 2274.001(3) of SB 19.

Required Confidential Information Status Form

Zoche LLC

Name of company

Michael Hunter - President

Printed Name and Title of authorized company officer declaring below the confidential status of material

130 N Wilson St.

Burleson

TX 76028

817.246.2223

Address

City

State ZIP

Phone

ALL VENDORS MUST COMPLETE THE ABOVE SECTION

CONFIDENTIAL INFORMATION SUBMITTED IN RESPONSE TO COMPETITIVE PROCUREMENT REQUESTS OF EDUCATION SERVICE CENTER REGION 8 AND TIPS (ESC8) IS GOVERNED BY TEXAS GOVERNMENT CODE, CHAPTER 552

If you consider any portion of your proposal to be confidential information and not subject to public disclosure pursuant to Chapter 552 Texas Gov't Code or other law(s), you **must attach a copy** of all claimed confidential materials within your proposal and put this **COMPLETED** form as a cover sheet to said materials then scan, name "CONFIDENTIAL" and upload with your proposal submission. (You must include all the confidential information in the submitted proposal. The copy uploaded is to indicate which material in your proposal, if any, you deem confidential in the event the receives a Public Information Request.) ESC8 and TIPS will follow procedures of controlling statute(s) regarding any claim of confidentiality and shall not be liable for any release of information required by law. Upon your claim and your defense to the Office of Texas Attorney General is required to make the final determination whether the information submitted by you and held by ESC8 and TIPS is confidential and exempt from public disclosure.

ALL VENDORS MUST COMPLETE ONE OF THE TWO OPTIONS BELOW.

OPTION 1:

I **DO CLAIM** parts of my proposal to be confidential and **DO NOT** desire to expressly waive a claim of confidentiality of all information contained within our response to the solicitation. The attached contains material from our proposal that I classify and deem confidential under Texas Gov't Code Sec. 552 or other law(s) and I invoke my statutory rights to confidential treatment of the enclosed materials.

IF CLAIMING PARTS OF YOUR PROPOSAL CONFIDENTIAL, YOU MUST ATTACH THE SHEETS TO THIS FORM AND LIST THE NUMBER OT TOTAL PAGES THAT ARE CONFIDENTIAL.

ATTACHED ARE COPIES OF _____ PAGES OF CLAIMED CONFIDENTIAL MATERIAL FROM OUR PROPOSAL THAT WE DEEM TO BE NOT PUBLIC INFORMATION AND WILL DEFEND THAT CLAIM TO THE TEXAS ATTORNEY GENERAL IF REQUESTED WHEN A PUBLIC INFORMATION REQUEST IS MADE FOR OUR PROPOSAL.

Signature _____ Date _____

OR

OPTION 2:

I **DO NOT CLAIM** any of my proposal to be confidential, complete the section below.

Express Waiver: I desire to expressly waive any claim of confidentiality as to any and all information contained within our response to the competitive procurement process (e.g. RFP, CSP, Bid, RFQ, etc.) by completing the following and submitting this sheet with our response to Education Service Center Region 8 and TIPS.

Signature  _____ Date 10.19.21 _____

Patios

Rooftops

Walkways

Landscapes



 **Exterior** Surfacing
by dinoflex





Dinoflex Exterior Surfacing

Performance proven in the harshest freeze/thaw climatic conditions, Dinoflex recycled rubber tiles and pavers provide durable, resilient, impact and sound absorbing surface ideal for new construction as well as renovation projects. Environmentally friendly and sustainable; our Exterior recycled rubber products are the right choice for high performance green landscaping and for rejuvenating old surfaces.

Commercial and Residential Applications:

- Green roofs
- Entryways
- Rooftops
- Porches
- Landscapes
- Stair treads
- Walkways
- Patios
- Gardens
- Decks



Colors:

Pigment*

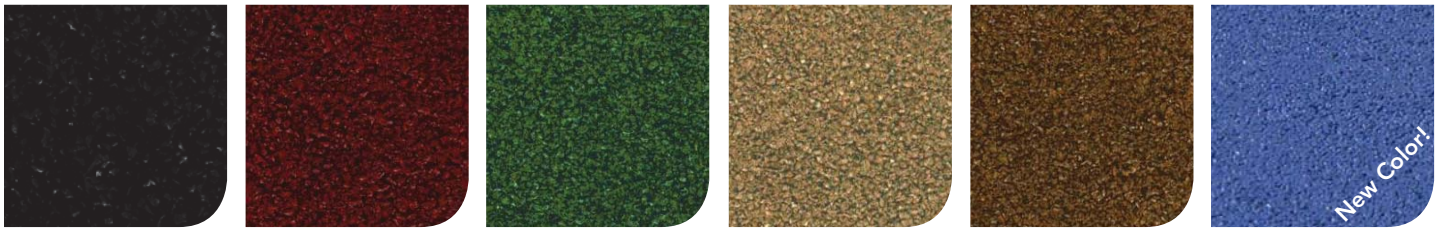

Black

Terra Cotta Red*

Forest Green*

Stone Beige*

Teak Brown*

Blue Ember*

*Variation in color occurs in all pigmented products. Pigmented tiles are not recommended for high traffic areas because of potential pigment loss.

EPDM Speckled

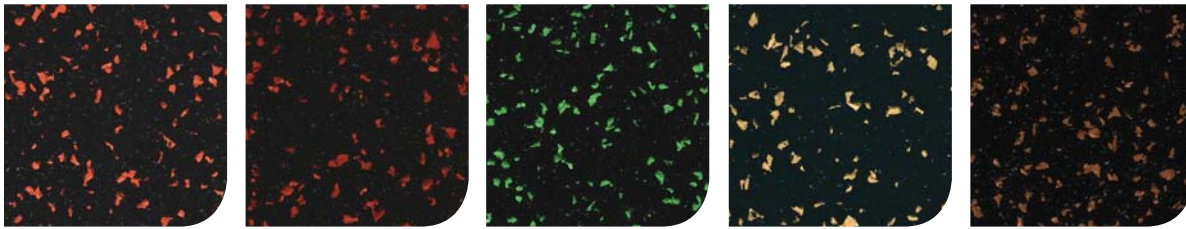

25% Orange

25% Red

25% Green

25% Beige

25% Brown

Note: Please select colors based on actual samples.

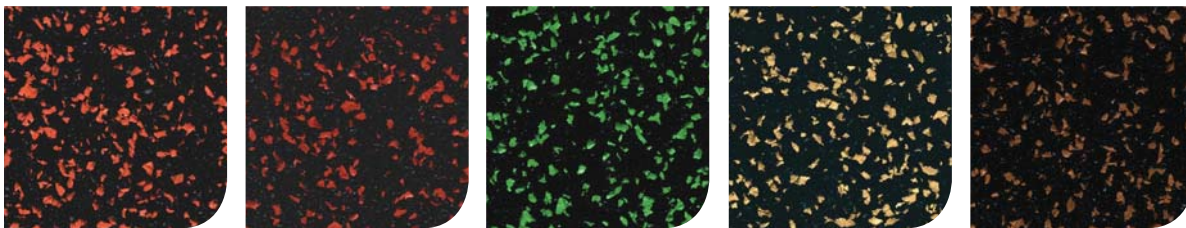

50% Orange

50% Red

50% Green

50% Beige

50% Brown

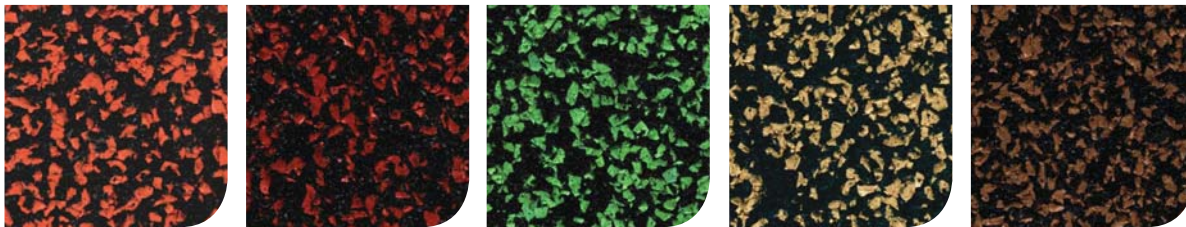

75% Orange

75% Red

75% Green

75% Beige

75% Brown

Customize your Color

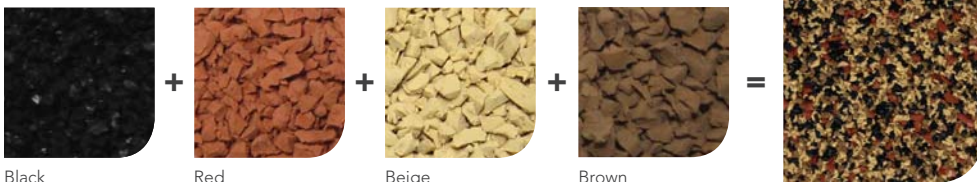

Black

Red

Beige

Brown

Note: Variation in UV stability can occur. The printed colors are reproduced as closely as possible to the actual product. Please contact your sales representative for more information.

Color blends available in concentrations up to 75% color

Accessories:



Cushionwalk
3/4" Reducer Strip



Adhesives
(tube, 2 gallon, and 5 gallon)



Finishing Kit



NuVISTA® Tiles



NuVista® Tiles provide superior noise reduction and high traction surfacing for rooftop patios, decks or walkways for apartment complexes, condominiums, office buildings, schools, restaurants and health care facilities. They can be installed over concrete, asphalt or a compacted granular base at grade, or over many types of roofing surfaces.

NuVista® Tiles also provide a non-vegetative border when used with green roof systems and can be used to create a high traction path to roof mounted mechanical systems. The recycled content combined with the regulation of water flow to roof drains, allow this product to contribute to LEED points.

Features:

- Noise reducing
- High traction
- Can be installed over concrete, asphalt and other types of roof surfaces
- Superior drainage for the regulation of water flow
- Heel resistant
- Interlocking tiles

Size:

- 1 3/4" 24" x 24" = 4 ft² (44 mm 61 cm x 61 cm = 0.37 m² 5.75 lbs/ft²)
- 2 1/2" 24" x 24" = 4 ft² (63 mm 61 cm x 61 cm = 0.37 m² 7.25 lbs/ft²)



The raised design of the NuVista tile backing provides improved water flow, ideal for landscaping applications.

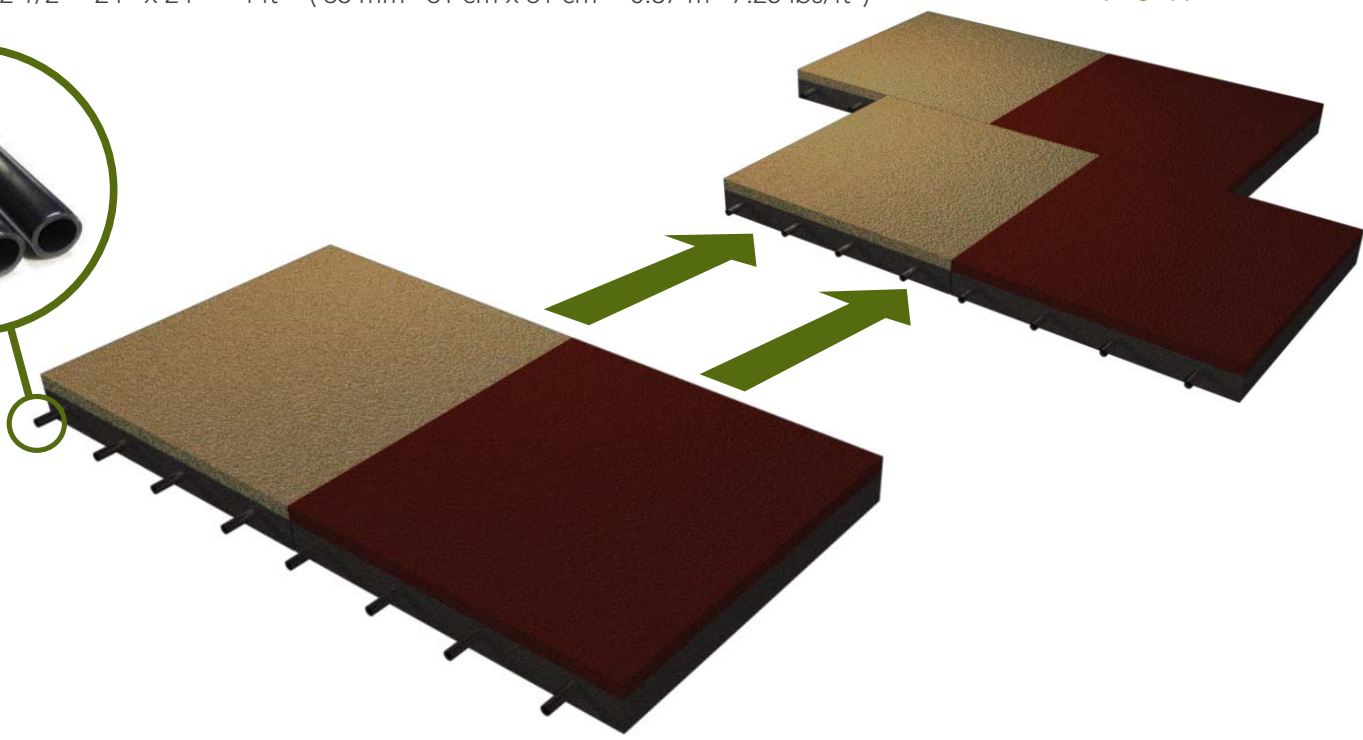
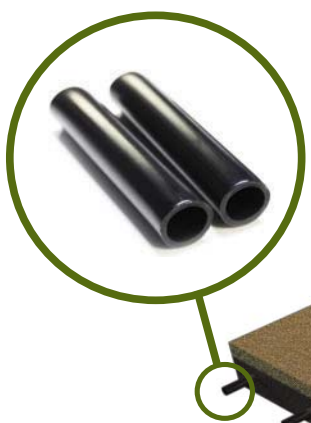



CushionWalk® Pavers



Cushionwalk® Pavers are resilient, long-lasting tiles which make them the perfect product for covering patios and walkways. Their impact absorbing and high traction qualities make for a safer and more comfortable walking surface. These tiles are often chosen for senior care facilities, exterior restaurant patios and many other commercial and residential applications. Available in both loose lay interlocking and glue down non-interlocking options.

Features:

- Impact absorbing
- Water permeable
- Noise reducing
- Stain resistant
- Lightweight
- Durable
- Low maintenance
- Heel resistant



Size:

- $3/4" \times 23 \frac{3}{4}" \times 23 \frac{3}{4}" = 3.92 \text{ ft}^2$ ($19 \text{ mm} \times 60 \text{ cm} \times 60 \text{ cm} = 0.36 \text{ m}^2$ 3.75 lbs/ft^2)
- Available in smooth and brick top design

Interlocking CushionWalk Pavers:

- $3/4" \times 24" \times 24" = 4 \text{ ft}^2$ ($19 \text{ mm} \times 61 \text{ cm} \times 61 \text{ cm} = 0.36 \text{ m}^2$ 4.00 lbs/ft^2)
- Available in smooth and brick top design

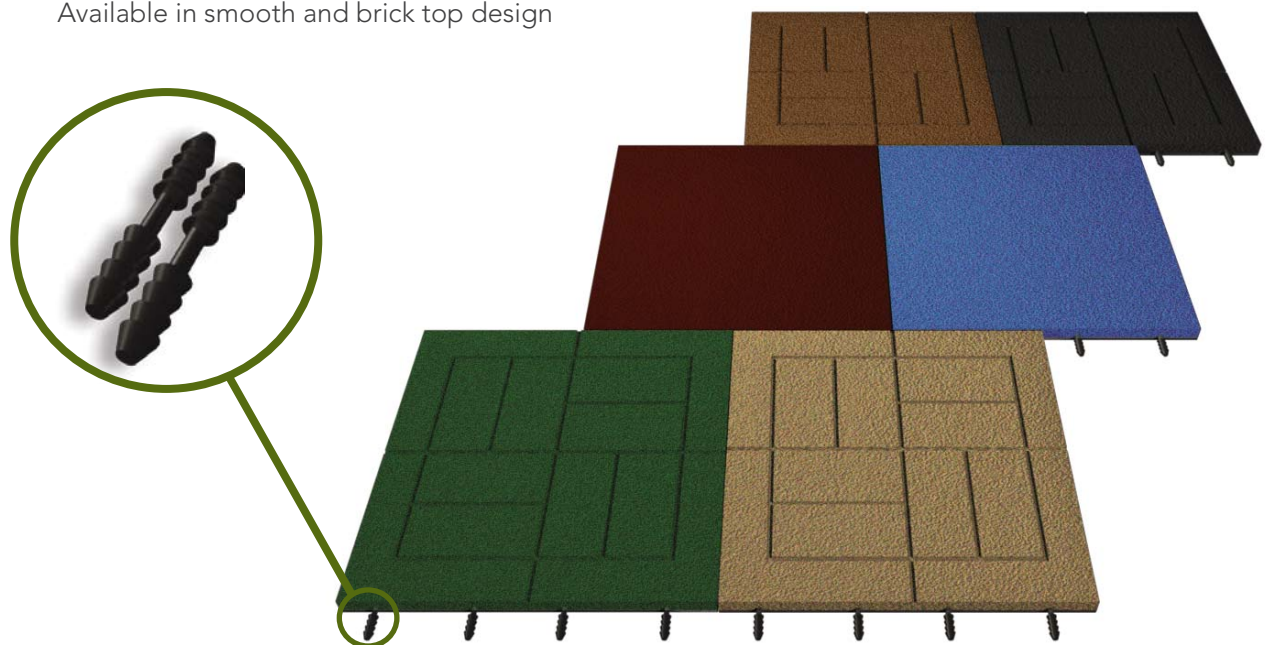

Please Note: All measurements are subject to nominal variation.

Let Us Introduce Ourselves

Dinoflex has been a leading innovator in the manufacturing of recycled rubber products for over 25 years. We specialize in producing premium quality rubber flooring, exterior tiles and custom products. Our merchandise provides solutions for architects, designers and builders that are cost effective and environmentally friendly.

LEED – Leadership in Energy and Environmental Design

Dinoflex recycled rubber products help qualify for LEED credits. Please refer to www.dinoflex.com for more information.

CushionWalk® Pavers Technical Data

TEST	DESCRIPTION	CUSHIONWALK® PAVERS
ASTM C518	Thermal Transmission Properties	R – Value 0.79t
ASTM C1028	Static Coefficient of Friction	Dry – 0.68; Wet – 0.75 (Pigment Color)
ASTM C1028	Static Coefficient of Friction	Dry – 0.74; Wet – 0.78 (50% color)
ASTM D395B	Compression Set Under Force	90.8% recovered
ASTM D412	Tensile Strength	298.9 lbs/in ²
CPSC FF 1-70	Burning Pill Test	Pass

NuVISTA® Tiles Technical Data

TEST	DESCRIPTION	NUVISTA® TILES
ASTM C1028	Static Coefficient of Friction	Dry – 0.73; Wet – 0.81 (Pigment Color)
ASTM C1028	Static Coefficient of Friction	Dry – 0.79; Wet – 0.81 (50% color)
ASTM D573	Aging Weathering	No effects

For complete specifications and technical data, please visit our website at www.dinoflex.com

5 YEAR WARRANTY



Dinoflex
P.O. Box 3309
5590 46 Ave S.E.
Salmon Arm, B.C., Canada
V1E 4S1

Toll Free: 1.877.713.1899
Direct: 250.832.7780
Email: info@dinoflex.com

www.dinoflex.com



Represented By:



Publication Date:
September 2014

Let Us Introduce Ourselves

Dinoflex has been a leading innovator in the manufacturing of recycled rubber products for over 25 years. We specialize in producing premium quality rubber flooring, exterior tiles and custom products. Our merchandise provides solutions for architects, designers and builders that are cost effective and environmentally friendly.

Interlock Tile (Loose Lay):

- Size**
 ☒ 37" x 37" = 9.5 ft² (94 cm x 94 cm = 0.88 m²)
- Standard Thickness**
 ☒ 9/32" (7mm) , 5/16" (8mm)
 ☒ Tolerance of +/- 0.5mm

Square Cut Tile (Glue Down):

- Size**
 ☒ 38" x 38" = 10.0 ft² (96.5 cm x 96.5 cm = 0.93 m²)
- Standard Thickness**
 ☒ 5/32" (4mm) , 3/16" (5mm) , 1/4" (6mm),
 9/32" (7mm) , 5/16" (8mm)
 ☒ Tolerance of +/- 0.5mm

Nature's Collection Technical Data

TEST	DESCRIPTION	RESULTS
ASTM C423-09A	Sound Absorption/Noise Reduction Coefficient	6mm 0.04
ASTM C501	Taber Abrasion (H-22)	1.39% wt. Loss
ASTM D2047	Static Coefficient of Friction (James Machine Method)	Dry 0.78
ASTM D2240	Hardness Shore A Durometer	65 Indentation
ASTM D395B	Compression Set Under Force at 25%	82.2% Recovered
ASTM D412	Break Load and Elongation	204.4 lbs/sq. in.
ASTM E648	Critical Radiant Flux (Fire Test)	0.39 Watts/sq cm
ASTM E492-09	Impact Sound Transmission	6mm - IIC 58
ASTM F137	Flexibility	6mm Mandrel PASS
ASTM F-150 (NFPA 99)	Electrical Resistance: • Surface to Surface • Surface to Ground	2.8 x 10 ¹¹ Ohms 4.0 x 10 ¹⁰ Ohms
ASTM F1914	Short Term Indentation and Residual Indentation	0.064 inch
ASTM F970	Static Load (250 lbs)	0.009 inch residual compression

Please Note: All measurements are subject to nominal variation.

For complete specifications and technical data, please visit our website at www.dinoflex.com

10 YEAR WARRANTY



Dinoflex
 P.O. Box 3309
 5590 46 Ave S.E.
 Salmon Arm, B.C., Canada
 V1E 4S1

Toll Free: 1.877.713.1899
 Direct: 250.832.7780
 Email: info@dinoflex.com

www.dinoflex.com



Represented By:



Publication Date:
 August 2016

Retail

Hospitality

Commercial

Education

NATURE'S Collection
 Cork infused flooring by dinoflex





Nature's Collection Flooring

The Nature's Collection seamlessly blends the utility and versatility of rubber with the style and sophistication of sustainably harvested cork. By infusing cork into our recycled rubber we have combined characteristics that are similar yet complimentary to one another giving you a product with superb performance and a visual dimension not typically found with rubber surfaces. With 20 colors to choose from, Nature's Collection offers you a wide palette to create a unique space with subtle natural tones. Applying a treatment of DinoCoat is recommended for the best finish.

Incorporating cork in our product provides these distinct advantages:

- Increased insulation properties
- Produced from a renewable resource
- Natural resistance to mold and mildew
- Unique color blends



Features:

- Long life expectancy
- Superior sound and impact absorption
- Easy maintenance
- Renewable content
- High traction
- Improved underfoot comfort
- Floorscore® certified
- Contributes to LEED credits

Best Applications:

- Retail
- Hospitality
- Commercial spaces
- Education
- Multi use facilities

Colors:

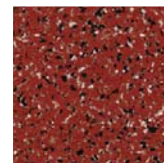

Monarch

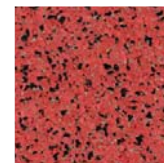

Cherry Blossom

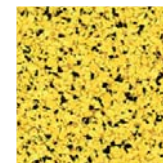

Daffodil

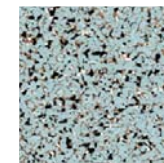

Waterfall

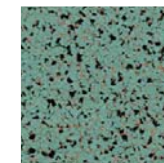

Caribbean

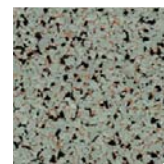

Meadow Grass

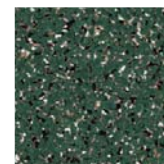

Pine Tree



Moss

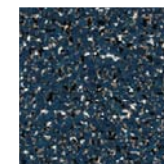

Ocean

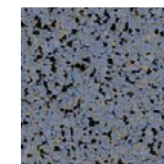

Blue Bells

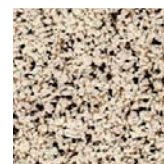

Orchid

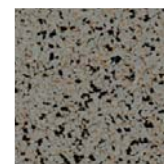

Stone



Fossil

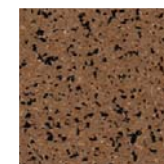

Canyon



Bark

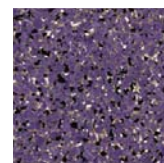

Iris

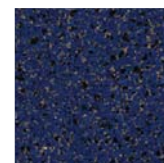

Sapphire

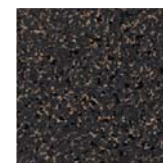

Ashes



Coffee Bean



Moon Shadow

Colors shown are reproduced as closely as possible to actual product. Contact Dinoflex for product samples.

Assisted Living

Education

Hospitality

Commercial

Retail

Multi-Family

 **NEXT STEP™**
by dinoflex

Walk Soft Luxury Vinyl Tile



*This product is currently not available in the USA.





Luxury Vinyl Tile Flooring

Dinoflex's newly minted Luxury Vinyl Tile Series has been designed to offer our clients an environmentally friendly flooring option, which authentically replicates the natural beauty and luxurious style of hardwood, concrete and marble. Backed with our WalkSoft recycled rubber material, our single step glue down tiles provide a quick and virtually seamless installation.

Luxury Vinyl Tiles provide a flooring option that is low maintenance and can be installed over existing hard surface flooring. Our unique recycled rubber backing provides the following distinct advantages:

- Sound reduction
- Ergonomic benefits for underfoot comfort. Testing shows an 85% improvement in ergonomic behaviour over LVT alone
- Thermal benefits to reduce heating costs
- Reduced total cost of ownership (TCO) due to substantial reduction of installation costs
- No Underlay or double step glue down process required
- WalkSoft backing provides reduced fall consequences



Applications:

- Assisted Living
- Multifamily
- Education
- Hospitality
- Commercial
- Retail
- Fitness/Cardio
- Residential

Features:

- Realistic patterns replicating the most popular styles on the market
- Single step installation process significantly reduces labor costs
- Nano ceramic coating for durability and reduced maintenance costs
- Low VOC Emissions
- Sound Absorbing
- Minimum 60% - 75% recycled content by weight depending on format
- Walk Soft Backing is FloorScore certified
- Warranty Protected

Formats:

LVT Top Layer	WalkSoft Backing	Total Thickness
6mil (.15mm), 2mm Recycled	3mm, 5mm	5mm, 7mm
8mil (.20mm), 2mm Recycled	3mm, 5mm	5mm, 7mm
12mil (.30mm), 2mm Recycled or Virgin	3mm, 5mm	5mm, 7mm
20mil (.51mm), 2.5mm Recycled or Virgin	3mm, 5mm	5.5mm, 7.5mm
20mil (.51mm), 3mm Recycled or Virgin	3mm, 5mm	6mm, 8mm

Standard Thickness Tolerance: +/- 0.5 mm

(Bolded = indicates special order)

Available Patterns:



Let Us Introduce Ourselves

Dinoflex has been a leading innovator in the manufacturing of recycled rubber products for over 25 years. We specialize in producing premium quality rubber flooring, exterior tiles and custom products. Our merchandise provides solutions for architects, designers and builders that are cost effective and environmentally friendly.

Sizes:

- 18.5" x 37" plank (47 cm x 94 cm)
- 37" x 37" tile (94 cm x 94 cm)

NEXT STEPTM Walk Soft Luxury Vinyl Tile Technical Data

TEST	DESCRIPTION	RESULTS
ASTM C518-10	Thermal Transmission Properties	Minimum 0.55-R-Value
ASTM D2240-05	Durometer - Shore Hardness	94 Shore A
ASTM D3574	Anti Fatigue Compression Deflection Comparison	2mm/5mm - 0.024" Deflection - 20lbs/sq. in. 2mm/5mm - 0.034" Deflection - 40lbs/sq. in.
ASTM D395(B)-14	Compression Set Under Force	≥ 95.1% Recovered
ASTM E2179-03	Impact Sound Transmission	IIC 50 - 51
ASTM E648-14a	Critical Radiant Flux (Fire Test)	Pass - 1.00 Watts/sq cm
ASTM F137-08	Flexibility of Resilient Flooring	6mm Mandrel PASSES
ASTM F1914-07	Short Term Indentation	≤ 0.014" (4.67%) Loss
ASTM F2199-09	Dimensional Stability after Heat Exposure	≤ 0.006" /12" L (-0.05%) and 0.007" /12" W (0.06%)
ASTM F511-11	Quality Of Cut	Average width of Space between tiles = 0.36mm Max opening where 4 corners meet = 0.89mm Edge Condition Comments = No burrs, nicks or chipped edges
ASTM F970-07	Static Load (250 lbs)	0.002 (0.2%) residual compression (5mm)

Please Note: All measurements are subject to nominal variation.

For complete specifications and technical data, please visit our website at www.dinoflex.com

Contact Dinoflex for specific warranty details.



Dinoflex
P.O. Box 3309
5590 46 Ave S.E.
Salmon Arm, B.C., Canada
V1E 4S1

Toll Free: 1.877.713.1899
Direct: 250.832.7780
Email: info@dinoflex.com

www.dinoflex.com



*This product is currently not available in the USA.

Represented By:



Publication Date:
December 2014

Schools

Parks

Day Cares

Play Areas

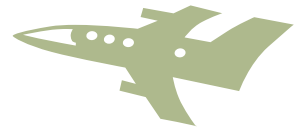
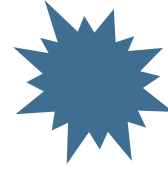
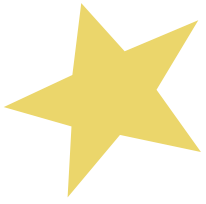

 **PlayTiles**®
by dinoflex

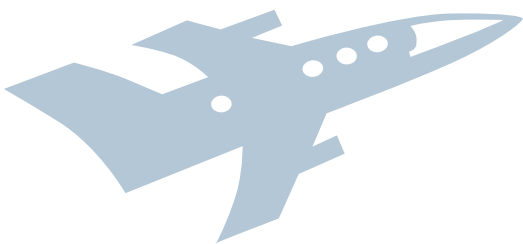



PlayTiles®

Dinoflex PlayTiles® are specifically designed to reduce injuries from falls under the guidelines set out under the ASTM F1292 standards. These tiles are ideal for schools, parks, daycares, multi-family playgrounds, backyard play areas and can even be used with indoor or outdoor climbing walls. The unique interlocking system can easily be installed over concrete, asphalt or compacted gravel. In addition, these tiles provide you the option of incorporating designs and symbols into the surface to make it even more appealing to children – imagine hopscotch or the alphabet built right into your playground surface. Use Dinoflex PlayTiles® to create a fully accessible playground surface that can be used in virtually any weather and is tough enough to stand up to the most active children.

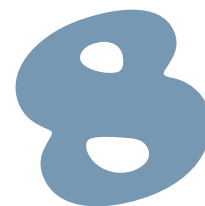

PlayTiles®

Fall Height

4 ft. / 1.2 m
6 ft. / 1.8 m
8 ft. / 3.0 m

Thickness

1 1/2" / 38 mm
2 1/4" / 57 mm
3 1/2" / 89 mm

Need a higher fall height?

Ask about our Dinofall system that creates a fall height of up to 11 ft.

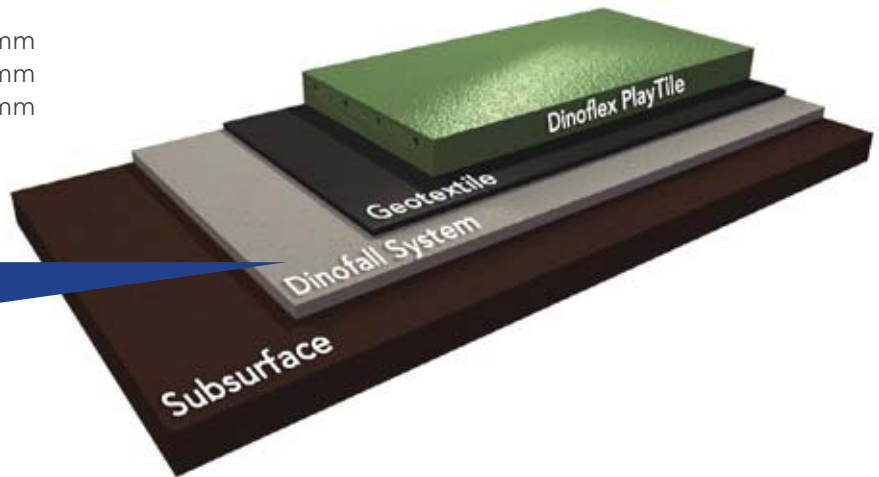

Interactive Tiles:

Turn your playground into a one-of-a-kind space that promotes learning, creativity and fun by adding one or more of our colorful Game sets to your surface.



Traffic Set



Alphabet Set



Hopscotch Set



Space Set



Colors:

Pigment*

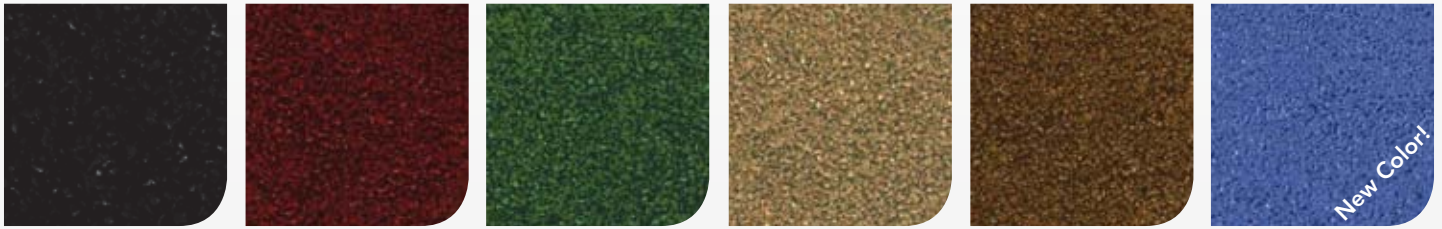

Black

Terra Cotta Red*

Forest Green*

Stone Beige*

Teak Brown*

Blue Ember*

*Variation in color occurs in all pigmented products. Pigmented tiles are not recommended for high traffic areas because of potential pigment loss.

EPDM Speckled

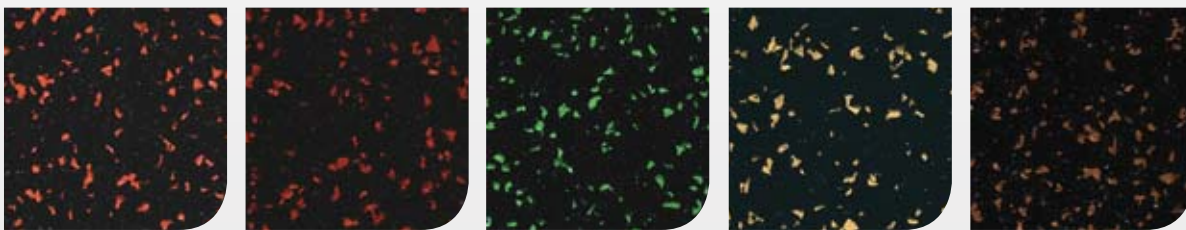

25% Orange

25% Red

25% Green

25% Beige

25% Brown

Note: Please select colors based on actual samples.

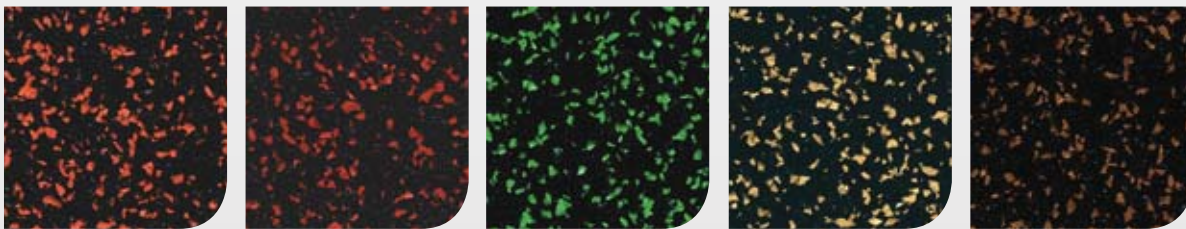

50% Orange

50% Red

50% Green

50% Beige

50% Brown

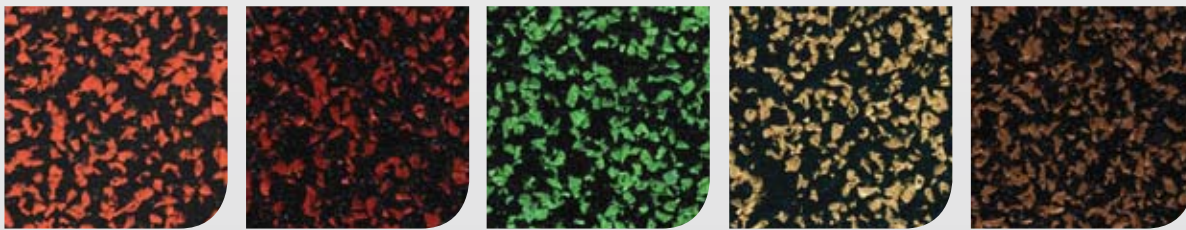

75% Orange

75% Red

75% Green

75% Beige

75% Brown

Interlocking System



Dinoflex self-aligning interlocking system provides for a fast and accurate installation.

Interlocking tubes at no charge with every order.



Accessories:

Ramps and Wedges



1.5" Outside Corner



Inside Corner



Outside Corner



1.5" Wedge



2.25" Wedge



3.5" Wedge



Wheelchair Ramp

Binders



Adhesives
(tube, 2 gallon, and 5 gallon)



Finishing Kit



PlayTiles® Technical Data

TEST	DESCRIPTION	PLAYTILES
ASTM F1292-09	Impact Attenuation	Results: Passed - Shock absorbing properties tested between 30 °F - 120 °F (0 °C - 50 °C). G-Max and HIC measured may not exceed 200 and 1000, respectively at a given fall height.
ASTM C1028	Slip Resistance	Results: Passed - Dry .73, Wet .81
ASTM D573	Aging Weathering	Results: No cracking, crazing, whitening or noticeable color change.
ASTM C67	Freeze / Thaw	Results: No cracking, crazing, whitening or noticeable color change.

Dimensions:

- 19 1/2" x 19 1/2" = 2.64 ft² (49.5 cm x 49.5 cm = 0.24 m²)
- 24" x 24" = 4 ft² (61 cm x 61 cm = 0.37 m²)

Features:

- Easily installs on compacted soft ground or solid surfaces
- Meets ASTM F1292-09
- Water permeable
- High traction
- Durable
- Low maintenance
- Meets ADA standards
- Qualifies for LEED credits
- Interlocking system - No glue required

Applications:

- Schools & Parks
- Day Cares
- Preschools
- Back Yards
- Play Areas
- Climbing Walls

10 YEAR LIMITED WARRANTY



Dinoflex
P.O. Box 3309
5590 46 Ave S.E.
Salmon Arm, B.C., Canada
V1E 4S1

Toll Free: 877.713.1899
Direct: 250.832.7780
Email: info@dinoflex.com

www.dinoflex.com



Represented By:



Publication Date:
June 2014

Fitness

Ice Arenas

Schools

Ski Resorts

SPORT MAT

by dinoflex



Made Flat **Stays Flat**™



Recycled
Rubber Flooring

Let Us Introduce Ourselves

Dinoflex has been a leading innovator in the manufacture of recycled rubber products for over two decades. We specialize in producing premium quality rubber flooring, exterior tiles and custom products. Our merchandise provides solutions for architects, designers and builders that are cost effective and environmentally friendly.

Sport Mat Flooring

Dinoflex has the perfect product for indoor fitness and sports facilities. Our incredible Sport Mat flooring is installed with ease and provides a durable, long-lasting solution for everything from weight rooms, and ice arenas, to multi-purpose recreation centers and ski resorts. It reduces noise levels, absorbs shock, prevents slipping and is environmentally friendly. This innovative flooring is available in our precision cut interlocking tiles and square cut tiles.



Testimonials

From Kyle Rhodus, Athletic Director
MWR Yokosuka, Japan

"The Dinoflex flooring has been an excellent upgrade to our fitness facility. It was easy to install, and immediately transformed the professional look of our gym. Since our first installation I have ordered this flooring for all my facilities."

Note: in total Kyle has ordered enough Sport Mat and Logo tiles to cover 34,210 sf of fitness flooring in Yokosuka.

From Diane Wilson, General Manager
Ann Arbor Ice Cube, United States

"After ordering the Dinoflex Sport mats for more than 8 years now, we have been "chipping away" at doing the entire lower level of our 155,000 sq ft facility. The first area we did has traffic of tens of thousands of people each year... and every place we have it still looks great. It is thick, with many colors and wears very well...even being constantly walked on with skates. I just placed an order for the USA Hockey National Team Development Program's weight room. It is easy to install and low maintenance!"

Custom Design:

By using our water cutter technology we are able to create a rubber floor that is both functional and visually appealing, achieving looks that are bold and daring, or subtle and refined. Utilize your valuable floor space by displaying company logos or brand elements throughout a facility. Write a message to customers in a strategic location or create play and learning areas for children. This technology also gives the ability to clearly mark exits or draw attention to merchandise. Bring your imagination to life – the possibilities are endless.



Custom Color Mixing



Custom Color Match Service:

- Available for square cut and interlocking tiles.
- Create your own custom floor colors. The following colors are available for custom design:



Contact your sales rep for more information.

Note: Please select colors based on actual samples.

Colors:

Standard Colors

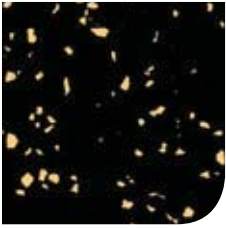

10% Beige - 5122

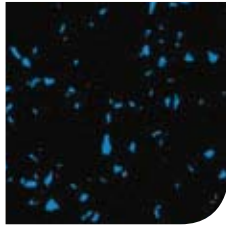

10% Blue - 5120

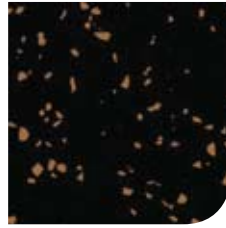

10% Brown - 5111

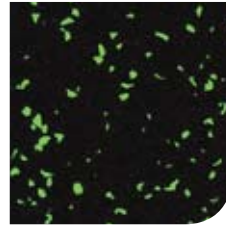

10% Green - 5119

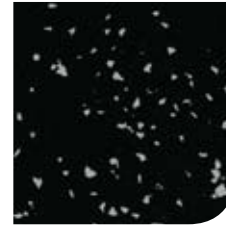

10% Grey - 5121

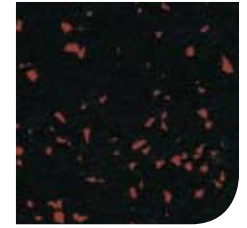

10% Red - 5118

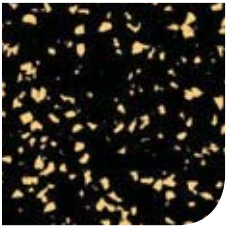

30% Beige - 5322

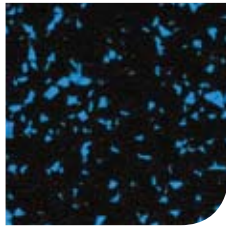

30% Blue - 5320

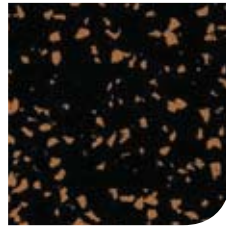

30% Brown - 5311

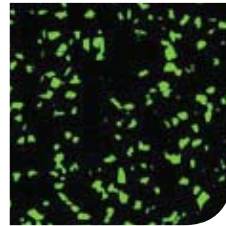

30% Green - 5319

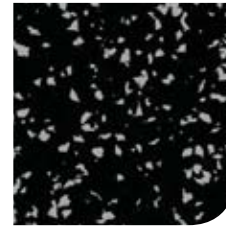

30% Grey - 5321

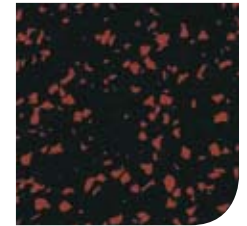

30% Red - 5318



50% Beige - 5522

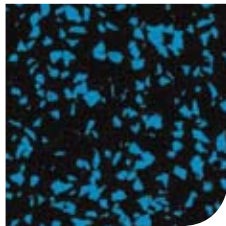

50% Blue - 5520

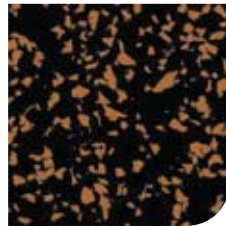

50% Brown - 5511

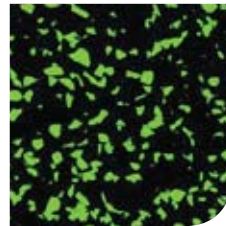

50% Green - 5519

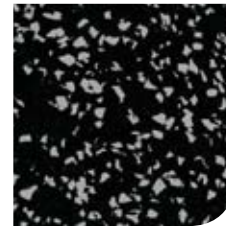

50% Grey - 5521



50% Red - 5518

Two-Color



10% Beige/Grey
5148

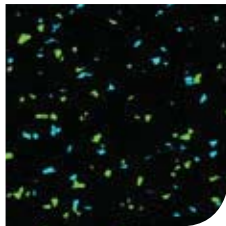

10% Blue/Green
5134

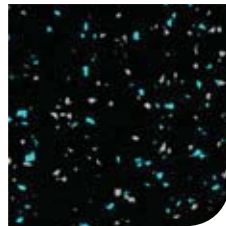

10% Blue/Grey
5145

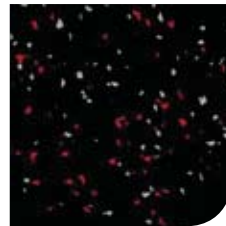

10% Red/Grey
5125

Note: Please select colors based on actual samples.

Metro

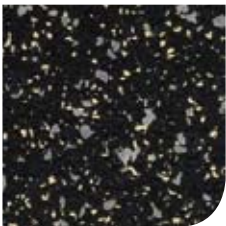

Metro Beige
214F06

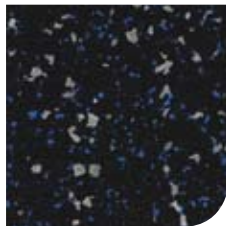

Metro Blue
214F5D

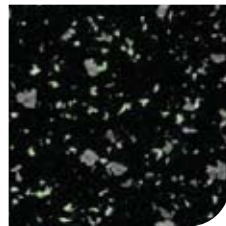

Metro Green
214FL3

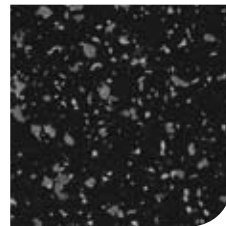

Metro Grey
214F05

Stone Line



Earthstone Beige
5004F6



Earthstone Orange
5004F9

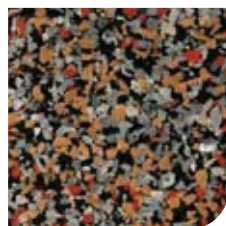

Earthstone Red
5004H3

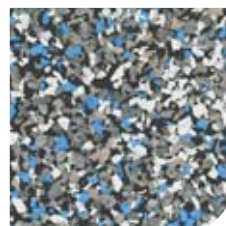

Seastone Blue
5004U7



Seastone Green
5004U2

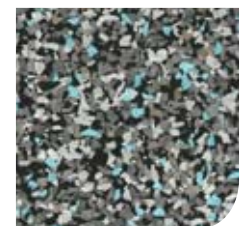

Seastone Turquoise
5004U8

Decor Collection

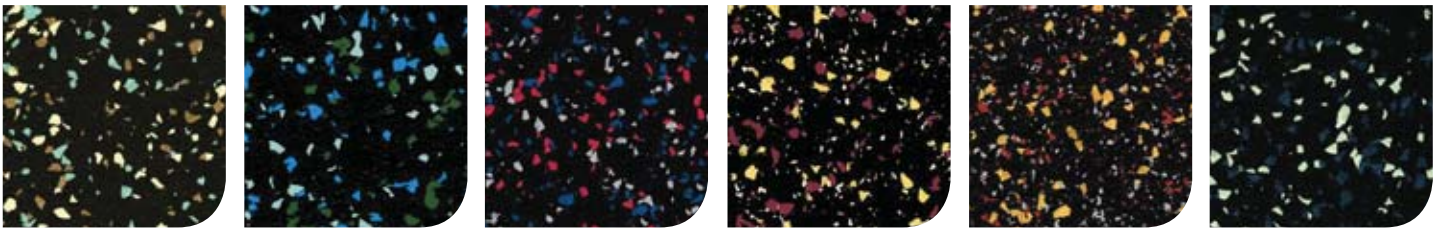

Aztek Empire
5304HE

Deep Sea
5304HB

Independance
5304HA

Lunar Showers
5314H9

Mayan Sands
5314H4

Night Sky
5304U3

Granite Flex

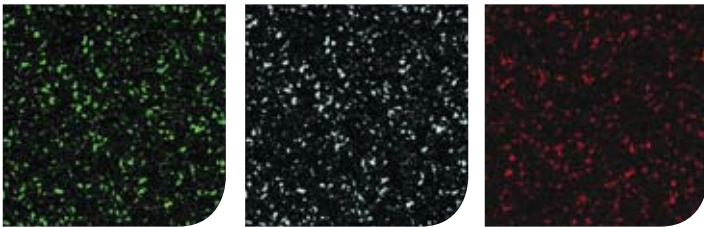

Green
53P119

Grey
53P121

Red
53P118

Granite Flex Plus

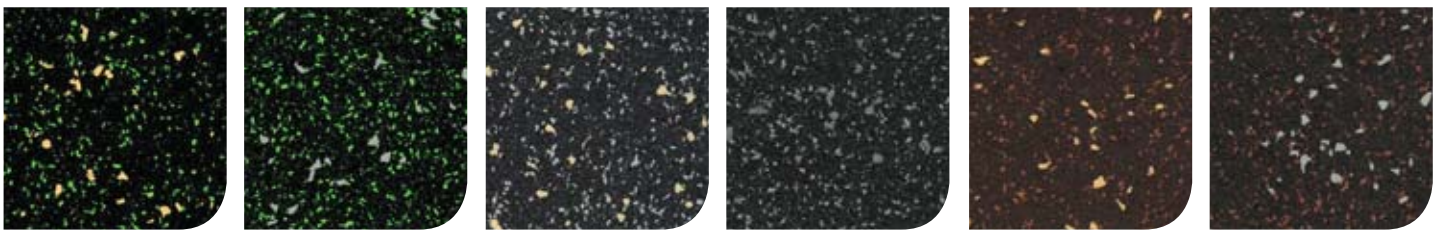

Green/Beige
54P436

Green/Grey
54P435

Grey/Beige
54P448

Grey/Grey
54P4Q9

Red/Beige
54P426

Red/Grey
54P425

Elite Line

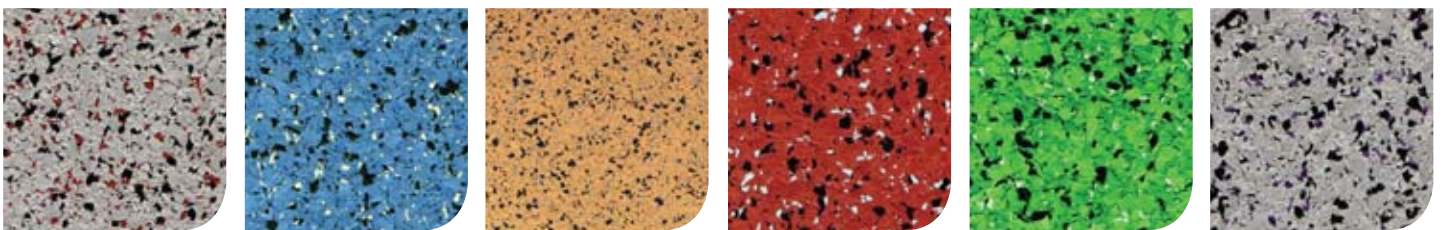

Gibraltar Grey
014C5

Mediterranean Blue
014C3

Sahara Beige
014C9

Sunset Red
014C4

Tropical Green
014C6

Tuscany Grey
014E7

Interlocking System - Loose Lay Flooring

Dinoflex CNC water jet equipment creates our tight fitting, precision cut interlocking tiles, resulting in a seamless, unified look for indoor spaces. These fully reversible tiles double the life of your floor and installation costs are reduced because adhesives are not required.

*Square cut tiles are also available for glue down applications where required

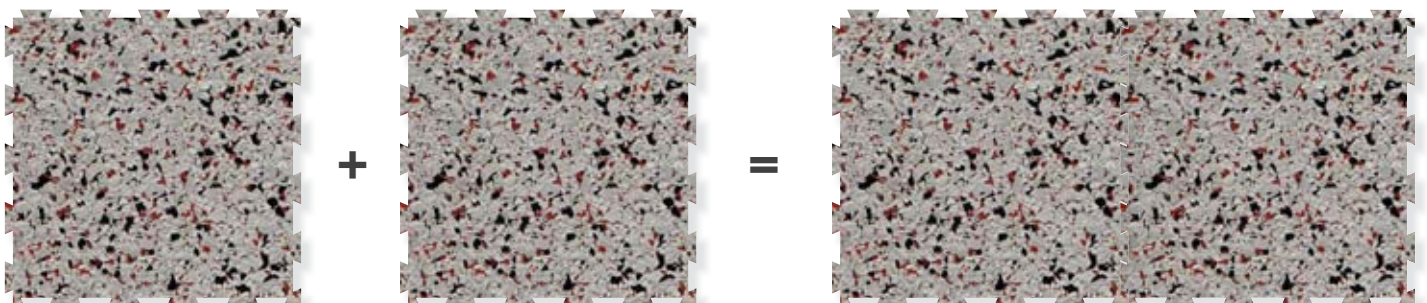



Hockey is His Expertise, Flooring is Ours.

"I recently decided to upgrade the flooring in my training facility – the room where I spend a great deal of my time. I wanted a high-quality product that was visually pleasing and easy to maintain. I also needed it to be durable enough to withstand rigorous everyday use... The finished floor is exactly what I envisioned. I am completely satisfied with Dinoflex's work and I would highly recommend them for any flooring needs."

- Endorsed by Ryan "Captain Canada" Smyth (18 Year NHL Veteran)

Features:

- Skate blade resistant
- Resistant to snow & ice
- Sound absorbing
- Shock absorbing
- Slip resistant
- Durable
- Low VOC

Applications:

- Fitness centres
- Recreation facilities
- Ski resorts
- Ice arenas

Interlock Tile (Loose Lay):

Size

- 37" x 37" = 9.5 ft² (94 cm x 94 cm = 0.88 m²)

Standard Thickness

- 5/16" (8mm) , 11/32" (9mm) , 3/8" (10mm) , 1/2" (12mm)
- Tolerance of +/- 0.5mm

Square Cut Tile (Glue Down):

Size

- 38" x 38" = 10.0 ft² (96.5 cm x 96.5 cm = 0.93 m²)

Standard Thickness

- 5/32" (4mm) , 3/16" (5mm) , 1/4" (6mm) , 9/32" (7mm) , 5/16" (8mm) , 11/32" (9mm) , 3/8" (10mm) , 1/2" (12mm)
- Tolerance of +/- 0.5mm

Please Note: All measurements are subject to nominal variation.

10 YEAR WARRANTY



Dinoflex
 P.O. Box 3309
 5590 46 Ave S.E.
 Salmon Arm, B.C., Canada
 V1E 4S1

Toll Free: 877.713.1899
 Direct: 250.832.7780
 Email: info@dinoflex.com

www.dinoflex.com



Made Flat **Stays Flat**™

Represented By:



Publication Date:
June 2014

Fitness Centres

Weight Rooms

Cardio Areas

Home Gyms



Stride Fitness Tiles

by dinoflex





Stride Fitness Tiles

Stride Fitness Tiles are the ideal flooring solution for workout areas located over occupied space. This non-laminated molded tile has superior vibration absorption and unparalleled noise reduction properties. The grid back design on the 1" tile has been engineered to provide increased stability for cardio and weight equipment. The 1 1/2" tiles provide additional sound reduction for free weight areas. Our self-aligning dowel interlocking system is installed without adhesives and can even be installed over existing rubber flooring. Stride Fitness Tiles are available in a full range of standard colors and custom colors are available upon request, with low minimum quantities required.



Features:

- Sound and Impact Absorbing
- Stain Resistant
- No Glue Interlock System
- High Traction
- Qualifies for LEED Credits
- Low VOC

Accessories



Wedge



Inside Corner



Outside Corner

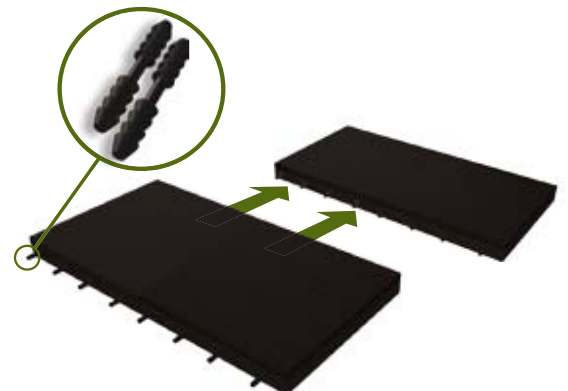

Interlocking System

Standard Colors

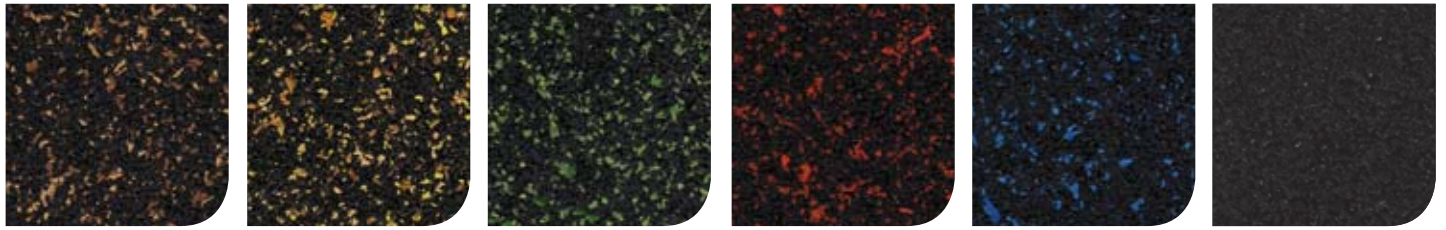

Amber

Citrine

Emerald

Ruby

Topaz

Black



Jasper

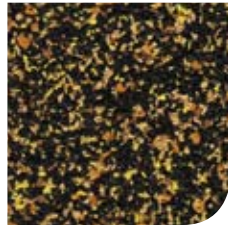

Quartz

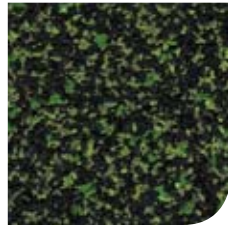

Jade

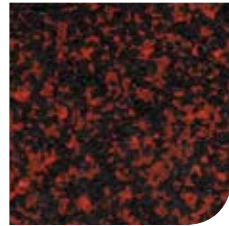

Garnet



Sapphire

Custom Colors:

- Choose from our extensive EPDM color inventory to create your own custom color blend with up to 75% concentration of color. Contact your sales rep for more information



60% Black

20% Purple

15% Turquoise

5% Royal Blue

Note: Please select colors based on actual samples. Variation in UV Stability can occur in custom color mixes.



Red



Blue

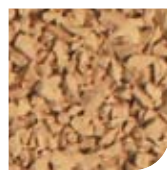

Beige



May Green



Purple



Orange



Grey



Brown



Hot Tamale



Royal Blue



Eggshell



Pastel Green



Blue Grey



Earth Yellow



Ash Grey



Sepia Brown



Rose



Ultra Marine Blue



Green Beige

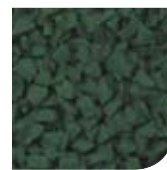

Signal Green



Pine Green



Yellow



Fawn



Charcoal



Heather Violet



Capri Blue



Aqua



Turquoise



Reed Green



Khaki



Pearl

Let Us Introduce Ourselves

Dinoflex has been a leading innovator in the manufacturing of recycled rubber products for over 25 years. We specialize in producing premium quality rubber flooring, exterior tiles and custom products. Our merchandise provides solutions for architects, designers and builders that are cost effective and environmentally friendly.

Sizes:

- Stride 1" (25mm) – 24" x 24" (4 ft2) / 61cm x 61cm (0.37 m2)
 - Stride 1 1/2" (38mm) – 24" x 24" (4 ft2) / 61cm x 61cm (0.37 m2)*
- *Stride 1 1/2" is NOT recommended for cardio areas.

Stride Fitness Tiles Technical Data

TEST	DESCRIPTION	LOW COLOR - Black, Amber, Citrine, Emerald, Ruby, Topaz	HIGH COLOR - Garnet, Jade, Jasper, Quartz, Sapphire
ASTM C423	Noise Reduction Coefficient	Sound Absorption 0.34 NRC 0.35	N/A
ASTM D2047-04	Static Coefficient of Friction (James Machine Method)	Dry 0.65, Wet 0.67	Dry 0.65, Wet 0.67
ASTM D2240	Hardness Shore A Durometer	65 indentation	68 indentation
ASTM D395	Compression Set Under Force (Method B)	97.8% Recovered	98.1% Recovered
ASTM D412	Tensile Strength	124.5 lbs/square inch	174.31 lbs/square inch
ASTM D4060	Taber Abrasion (H-19) 1000g Load	0.18% wt. loss	0.21% wt. loss
ASTM E492	Lab Measurement - Impact Sound Transmission	IIC = 58	N/A
ASTM E1007	Field Measurement - Impact Sound Transmission Stride 1.5" Tile	FIIC 61 - Pass Code Requirement: FIIC 45	N/A
ASTM E648-10	Critical Radiant Flux of Floor - Covering Systems Using a Radiant Heat Energy Source	Contact Dinoflex for results	Contact Dinoflex for results
ASTM F970	Static Load Limit (1000 lbs)	0.006 inch residual compression	0.008 inch residual compression
CA 01350	VOC Emissions - Section 01350	Pass	Pass

Please Note: All measurements are subject to nominal variation.

For complete specifications and technical data, please visit our website at www.dinoflex.com

5 YEAR WARRANTY



Dinoflex
P.O. Box 3309
5590 46 Ave S.E.
Salmon Arm, B.C., Canada
V1E 4S1

Toll Free: 1.877.713.1899
Direct: 250.832.7780
Email: info@dinoflex.com

www.dinoflex.com



Represented By:



Publication Date:
November 2014



A Surface Designed
for Dancers

DANCEFLOOR
Cushioned Vinyl



THE ULTIMATE
SURFACE EXPERIENCE

DANCEFLOOR
Cushioned Vinyl



THE STAGE IS SET

Dancefloor

Cushioned Vinyl



All dancers deserve a floor they can count on. Tarkett's Dancefloor has finely tuned properties for confident footing and cushion to reduce strain. It is specifically designed for the stage and studio needs of professionals, but with inclusive pricing for everyone.



Performance

Dance is a unique physical activity that has specific performance demands when it comes to flooring. Dancefloor meets those standards in a precise way. The floor does not have the polyurethane coating that is common to sports surfaces, which provides a surface with extra grip. It also generates a measure of shock absorption through a foam backing that reduces strain.

- 1 Dancer-Approved Surface Friction**
The textured surface of Dancefloor purposefully omits the polyurethane coating that is common to athletic flooring, giving the specific level of friction that most professional dancers prefer.
- 2 Wear Resistance**
Dancefloor contains a pigmented wear layer made from pure PVC, which carries an industry-leading 10-year product warranty.
- 3 Dimensional Stability**
A compact PVC layer with embedded non-woven fiberglass gives Dancefloor superior dimensional stability.
- 4 Structural Reinforcement**
With the layer above, this vinyl layer forms the strain-splitting core that contributes to Dancefloor's indentation recovery and dimensional stability.
- 5 Shock-Absorbing Acoustic Foam**
This foam layer has a dense cellular structure, providing shock absorption and impact sound insulation.

Health and the Environment

Dancefloor embodies Tarkett's four categories of sustainability, providing not only superior sports performance, but stewardship of the environment and care for individual health.



Good Materials

- Contains natural materials
- No REACH restricted chemicals
- No formaldehyde
- Free of heavy metals



Resource Stewardship

- ISO 14001 manufacturing
- 63% water reduction in six years
- 29% VOC reduction in six years
- 133% more recycling since 2003
- Tarkett's history of conservation



People-Friendly Spaces

- Low TVOC emissions: <math><10 \mu\text{g}/\text{m}^3</math>
- Requires no harsh chemicals
- Uses phthalate-free technology



Reuse and Recycle

- 100% recyclable*
- Contains recycled content

*Recycling facilities may not exist in your area. Transportation of the material may be required.



*except recycled content

Colors



Grey



Black

The colors presented here are representations only. An actual sample is recommended for exact color evaluation.

The Flooring Choice of the Australian Ballet

In every professional ballet performance, there is a lead role that the audience never sees, but each performer relies on—the floor. Tarkett's Dancefloor has been the preferred dance surface of the Australian Ballet for nearly 4 decades. The partnership began in 1974 when Production Director Bill Akers was tasked by the American Choreographer Glen Tetley to improve the Marley floor used by the Australian Ballet, which was strongly affected by humidity conditions. After collaborating with Tarkett, the worldwide leader in resilient vinyl surfaces, Dancefloor was created to meet performance needs as well as the practical requirements of the studio. The floor continues to be the preferred surface of the Australian Ballet and can be found in most major arts centers in Australia, including the Sydney Opera House. If you need a dance surface you can depend on, give Tarkett's Dancefloor a chance to audition. You won't regret it.

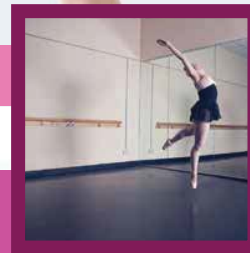
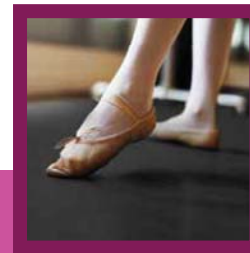

Dancefloor Inspiration

Dance can be physically demanding, but a true sprung floor can reduce strain and allow dancers to focus on creating art rather than battling fatigue. Tarkett's Inspiration provides high shock absorption, uniform response, and an optimized Dancefloor surface for grip.

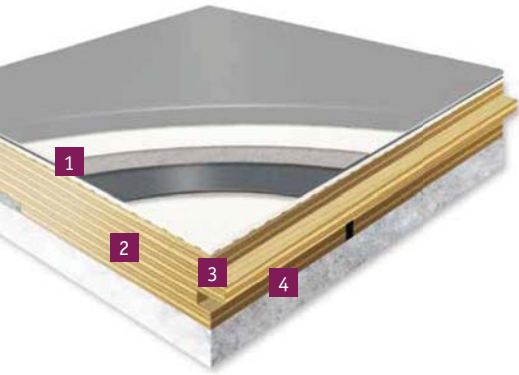

1 Dancefloor Point-Elastic Surface

With Tarkett's Dancefloor as the surface, Inspiration provides an optimized level of grip for dancers with a point-elastic response that deforms only at the area of immediate impact.

2 Uniform Structural Support

These 18 mm plywood planks provide stability and a uniform structure for resilient dance surfaces. They are made exclusively from birch, one of the most stable varieties of wood.

3 Reliable Bonding and Assembly

Each plywood plank incorporates an interlocking tongue-and-groove edge for fast and reliable installation.

4 Shock-Absorbing Foam Cushion

This shock-absorbing cushion is 1/2" thick. In addition to providing high levels of shock absorption, it is also GREENGUARD certified as a low-emitting interior building material.

Performance

Sprung floors are the pinnacle of dance surface performance and Tarkett's Inspiration is no exception. The floor provides a high level of shock absorption, averaging 52% per ASTM F2569. More importantly, Inspiration has superior uniformity in all key performance properties. That means dancers can rely on their expectations of the floor in every location.

Health and the Environment

Inspiration embodies Tarkett's four categories of sustainability, providing not only superior sports performance, but stewardship of the environment and care for individual health.



Good Materials

- Uses renewable resources
- Incorporates natural materials
- No formaldehyde



Resource Stewardship

- ISO 14001 manufacturing
- A history of conservation



People-Friendly Spaces

- GREENGUARD certified foam
- CRI Green Label certified foam



Reuse and Recycle

- Zero-landfill foam manufacturing
- Contains recycled content

Floors are Fundamental to Creating Art

Every musician knows that "the room" is a big part of musical quality. An instrument may sound beautiful in an outdoor venue, but only the resonance of a good concert hall can summon its full musicality. Think of dance in the same way. A talented dancer needs a good floor to elevate dance to the level of art—a floor that allows them to focus on performance rather than fatigue or potential stress injuries—that liberates them to create beauty through motion without second guessing each step.

Tarkett's Inspiration is a unique sprung floor system that supports dance performance like nothing else. The floor provides shock absorption to increase comfort without excessive bounce. It has uniform properties so dancers know what to expect in every corner of the stage or studio and the surface is Tarkett's Dancefloor resilient vinyl, which is designed for the friction dancers prefer.

Aside from its superior performance, *Inspiration* supports dancers in another very important way. It's attainable. Tarkett believes that cost should not be a barrier to any studio or company that wants a high performance sprung floor. The talent and dedication of every dancer calls for a surface with equal commitment to greatness.

So how do you boost a performer's routine to artistic brilliance? The first step is to give them *Inspiration*.

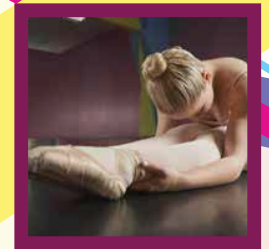
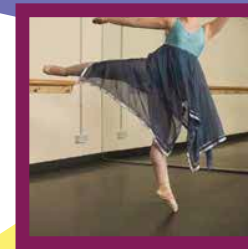
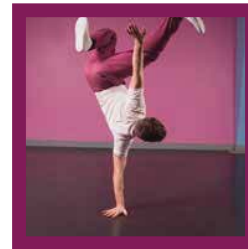
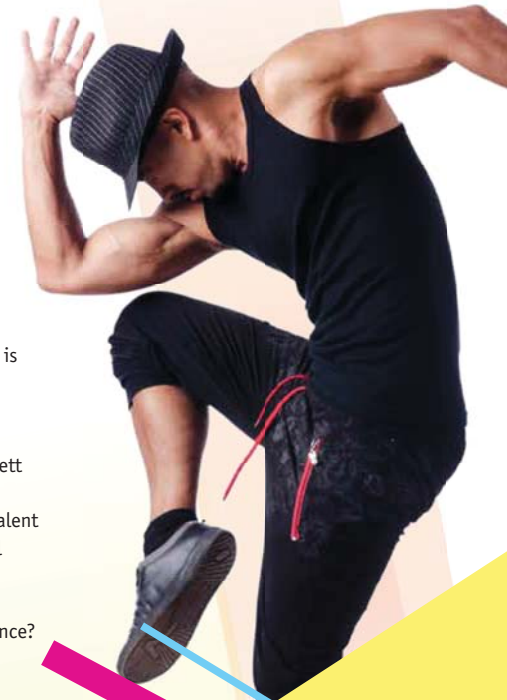

Tarkett Sports is a division of the Tarkett Group, which was established in 1886. The Tarkett Group has now reached over \$2.5 billion in annual sales and is a global leader in commercial, residential, and sports flooring.

For more information on Dancefloor, including technical data and specifications, call 888-364-6541.

The USGBC Membership logo is a trademark owned by the U.S. Green Building Council and is used with permission.



12/1/2017



 **Tarkett** SPORTS

DROPTURF

.....
BUILT FOR INTENSE, MULTISPORT TRAINING

**ATHLETES
COMMIT TO
THE GAME...
CHOOSE A
FLOOR THAT'S
COMMITTED
TO THE ATHLETE**



AN INDUSTRY LEADER

Tarkett Sports is a division of the Tarkett Group, which was established in 1886. The knowledge and expertise accrued by Tarkett over 130 years has made it one of the largest flooring manufacturers in the world.

With over \$3 Billion in annual sales and an average of 13 million square feet of flooring produced per day, Tarkett is a global leader in commercial, residential, and sports solutions.



BUILT STRONGER, TOGETHER

Tarkett Sports does it all. We offer a full range of surfacing products. From our line of commercial, residential and athletic artificial turf, sports tracks, and indoor flooring, we have the right solution to fit your needs. Tarkett Sports is built stronger, together.



WHY TARKETT SPORTS



TARKETT SPORTS BRAND

Tarkett Sports is a world leader in athletic surfacing, offering a comprehensive portfolio of sports flooring solutions through its brands: FieldTurf, Beynon Sports, Renner Sports, EasyTurf, Desso, GrassMaster, PlayMaster and Tarkett Sports Indoor.



DESIGN & CONSTRUCTION EXPERTS

Tarkett Sports and our partners are some of the most experienced and knowledgeable teams in the industry. When it comes to the design and construction of your sports surface, we are the experts.



FINANCIALLY STABLE

The Tarkett Group is a worldwide leader of innovative flooring and sports surface solutions. Tarkett Sports Indoor is backed by unprecedented financial support and stability. You can rest easy.



LEADING DURABILITY

Manufactured and installed with the highest attention to detail, Tarkett Sports Indoor's systems showcase proven durability.



EXPERIENCE

With over 5,000 installations in North America in the last 10 years, Tarkett Sports Indoor has the knowledge and expertise to make your sports facility a success.



TRUSTED

For indoor facilities, Tarkett Sports Indoor offers the most trusted sports flooring for various style facilities in North America.



ENDLESS PURSUIT OF INNOVATION

From the Dropzone rubber, PolyTurf Pad and Pour system, Omnisports vinyl sports flooring, ClutchCourt wood, and LinoSport linoleum, our innovation and versatility extend beyond just sports. We're there to support your team.



SERVICE

We are as committed to your program as you are, and we're with you for the long term. When you buy from Tarkett Sports, you're buying from a company that knows how to take care of you.

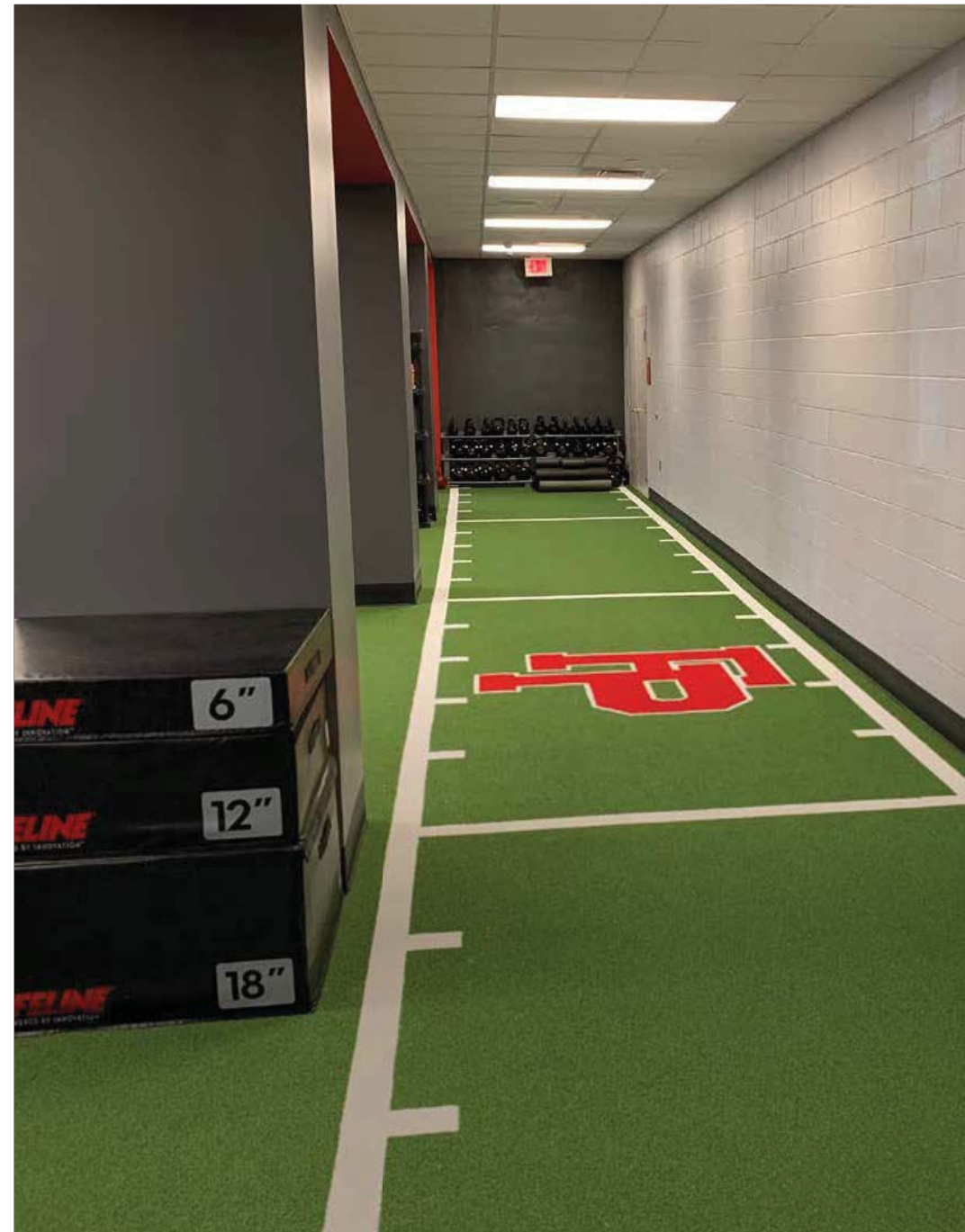

A TURKEY SOLUTION

WITH TARKETT SPORTS INDOOR



OMNISPORTS

The Game-Changing versatility of Omnisports

Applications: Gymnasium • Daycare • Multi-Purpose Rooms • Cafetorium • Yoga • Martial Arts



DROPZONE

The surface strength of Dropzone rubber flooring

Applications: Weight Rooms • Strength & Cardio Equipment • Spinning • Training Turf • Functional & Extreme Training • Ice Rinks



CLUTCHCOURT

Inspiring tradition of ClutchCourt Northern Maple

Applications: Gymnasium (Basketball & Volleyball) • Aerobics • Racquetball



POLYTURF PLUS PAD & POUR

The durable playing surface of PolyTurf Plus Pad & Pour

Applications: Multi-Purpose Rooms • Cafetorium • Gymnasium • Inline Skating



LUMAFLEX

The pinnacle of sports performance with LumaFlex

Applications: Gymnasium • Multi-Purpose Rooms • Inline Skating • Aerobic and Fitness



DANCEFLOOR

Perform at your best with Dancefloor

Applications: Dance Studio • Dance Stage



LINOSPORT

The natural sustainability of LinoSport Linoleum

Applications: Multi-Purpose Rooms • Gymnasium • Daycare



PORTABLE SPORTS FLOORING

The Ultimate Portable Sports System

Applications: Arenas • Temporary Basketball and Volleyball Court • Agility Area • Any Home Application

DROPTURF & EASYFIELD

BUILT THE RIGHT WAY

FIELDTURF MANUFACTURING

CERTIFIED TO MEET THE TOUGHEST STANDARDS

ISO 9001, ISO 14001 and ISO 45001 certified for leadership in quality, environment and safety management systems, our Calhoun facility represents one of the only artificial turf manufacturing operations in North America to have received these ISO certifications.



VERTICALLY INTEGRATED FOR COMPLETE CONTROL

FieldTurf controls all aspects of the manufacturing value chain. From start to finish, we're in control of your project.

► FIBER QUALITY

All fibers used in FieldTurf fields undergo stringent testing and quality control to ensure the yarn properties (tensile strength, uniformity & color verification) meet our high standards.

► TUFTING AND COATING

Once the fiber is produced, it is ready for tufting and coating which takes place at our 500,000 square-foot facility in Calhoun, Georgia. The Calhoun facility employs over 40 employees, with hundreds of years of experience combined in the artificial turf industry.





DROPTURF: BUILT FOR INTENSE, MULTISPORT TRAINING



.....

DropTurf features a strong textured polyethylene slit-film fiber designed specifically for intense indoor training areas. The system offers excellent durability with less abrasiveness than typical nylon or polypropylene carpets.

Combined with a 5mm foam backing, DropTurf doesn't sacrifice on comfort or performance.

With a multitude of available colors, you can truly make your facility unique. Backed by FieldTurf's leading reputation and quality, you can trust that DropTurf is the optimal solution for your training or indoor multisport area.

DROPTURF

18"

FELINE
ERED BY INNOVATION™



5 YEAR
PRODUCT WARRANTY

DROPTURF is a durable product that is manufactured by FieldTurf for indoor use. DropTurf features tough fibers for agility uses. DropTurf provides a much less abrasive surface than nylon or polypropylene and superior wear resistance to withstand the harshest treatment. DropTurf is approximately 25 mm thick, combining a 20 mm polyethylene turf with a 5 mm foam backing, providing superior safety & performance.

FORMAT OPTIONS



ROLLS
15' wide, custom length

APPLICATIONS



TURF/FIELDS



FUNCTIONAL TRAINING



EXTREME FUNCTIONAL TRAINING

SPECIFICATIONS

- ▶ FIBER HEIGHT: 0.75"
- ▶ FIBER TYPE: SLIT-FILM & THATCH
- ▶ GAUGE: 3/16"
- ▶ BACKING: 5 MM

BENEFITS

IDEAL FOR VARIOUS APPLICATIONS

DropTurf is ideal for indoor specialty sports, training facilities, CrossFit centers, and more.

ACCOMMODATES A LARGER NUMBER OF SPORTS AND ACTIVITIES

It comes standard in a blend color, in 15 foot widths and a 5mm foam backing

CUSTOM DESIGN POSSIBILITIES

Our exclusive water jet cutting system smoothly cuts some of the world's most sophisticated and beautiful turf designs. The end result is unrivaled detail, large color palettes, and the capability to create complex projects.

TARKETT SPORTS WARRANTY PROTECTION

The quality and performance of DropTurf is protected by Tarkett Sports with a comprehensive 5-year warranty.

COLOR SELECTION

DropTurf comes with **7 color options**, which makes it easy to create unique indoor designs or match the colors of a school or team. Other colors are available via custom order.



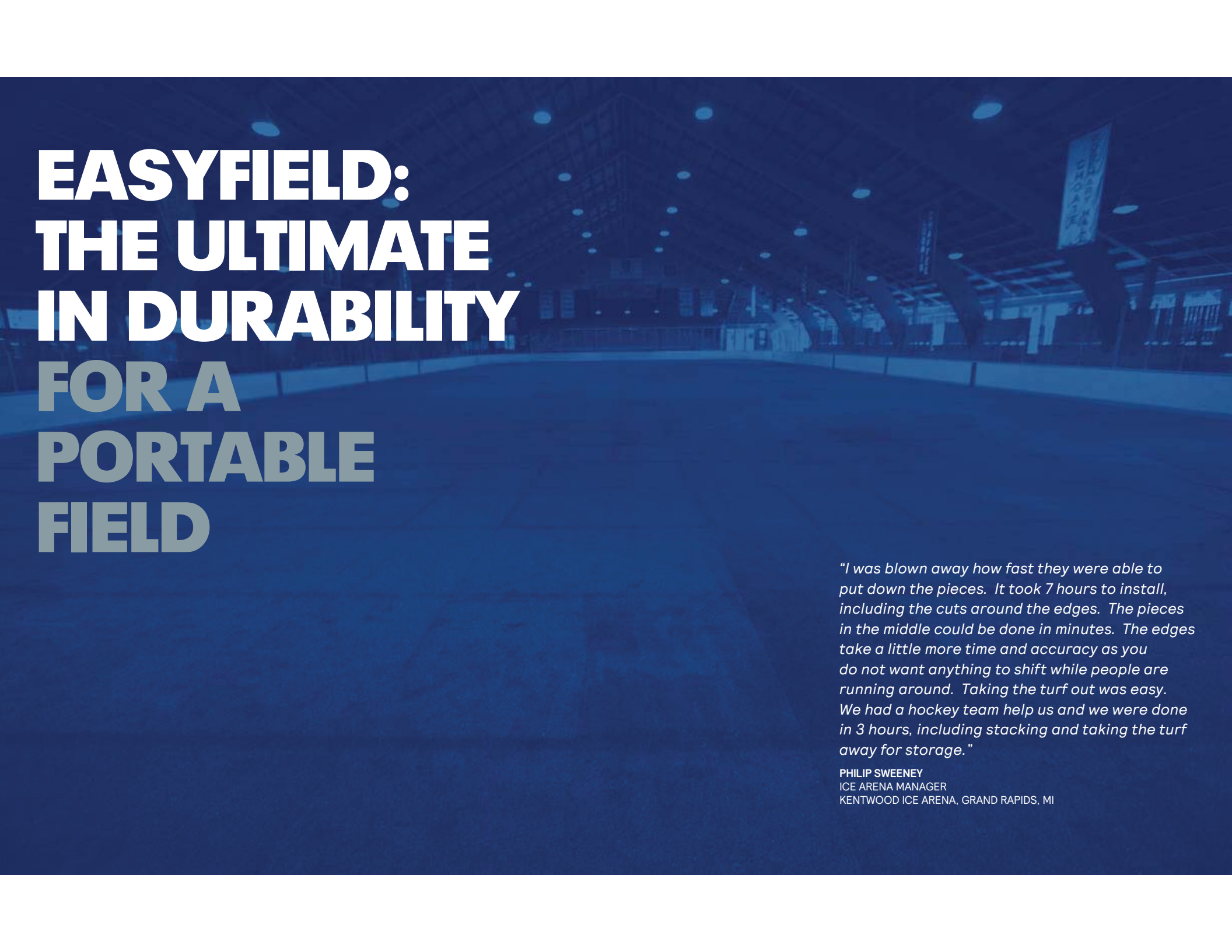

EASYFIELD: THE ULTIMATE IN DURABILITY FOR A PORTABLE FIELD

"I was blown away how fast they were able to put down the pieces. It took 7 hours to install, including the cuts around the edges. The pieces in the middle could be done in minutes. The edges take a little more time and accuracy as you do not want anything to shift while people are running around. Taking the turf out was easy. We had a hockey team help us and we were done in 3 hours, including stacking and taking the turf away for storage."

PHILIP SWEENEY
ICE ARENA MANAGER
KENTWOOD ICE ARENA, GRAND RAPIDS, MI

EASYFIELD BY FIELDTURF



1 YEAR
PRODUCT WARRANTY

EasyField by FieldTurf was designed with your facility in mind. It's a quick, convenient, portable, high performing indoor turf system. EasyField provides indoor facility owners with the ultimate in versatility - a durable, impact-absorbing turf system. FieldTurf engineered the easiest, fastest and most secure way of locking your portable field panels together.

FORMAT OPTIONS



EASY LOCKING TILE
5.17' (158 cm) x 3.44' (105 cm)
Thickness: 1.85" (47 mm)
Weight (Base & surface): 21 lbs. approx.

APPLICATIONS



SOCCER



LACROSSE



FIELD HOCKEY



GYM TURF /
AGILITY AREA



TRADE SHOWS /
TRADE
EXHIBITIONS /
EXPOS



FEATURES

DURABLE TURF

After 20,000 cycles on the Lisport Wear Machine, the turf still looks and plays great.

LIGHTWEIGHT CUSHIONED TILE

Excellent shock absorption for every athlete on your field.

EASY INSTALLATION

The EasyLock interlocking system is engineered to be the easiest, fastest and most secure way of locking your portable sports panels together.

A FULL FIELD IN LESS THAN A DAY

Our do-it-yourself system is so simple, a small crew of people can install a full size field (17,000 sq ft) in less than a day.

EASY-TO-HANDLE LIGHTWEIGHT TILES

Individual tiles weigh less than 25 lbs, which means EasyField can be installed by almost anyone.

DURABLE SAFETY

EasyField's 45mm compressed foam pad provides excellent Gmax and shock absorption.

TARKETT SPORTS WARRANTY PROTECTION

The quality and performance of EasyField is protected by Tarkett Sports with a comprehensive 1 year warranty.

EASYFIELD: HIGH PERFORMING PORTABLE SURFACES

PROPERTY	STANDARD	VALUE
Gmax (Shock Absorption)	ASTM F355	83G
Force Reduction	EN 14808	61%
Deformation	EN 14809	7.5 mm
Energy Restitution	IRB	37%
Ball Rebound	FIFA 08	0.64 m
Ball Roll	EN 12234	6.5 mm

EASYFIELD PORTABLE SPORTS PANELS

MADE FOR YOU

EASYLOCK INTERLOCKING SYSTEM

The EasyLock interlocking system is engineered to be the easiest, fastest and most secure way of locking your portable sports panels together. EasyLock is a simple male-female interlock system that fits your panels together perfectly for a seamless feel.

THE PERFECT PANEL SIZE

Each portable panel has a dimension of 5.17 ft x 3.44 ft. Weighing less than 25 pounds, each panel is extremely lightweight for easy carrying, maneuvering and installation.

FROM FLOOR TO FIELD IN NO TIME

Installing a good sports field has never been this easy. Our do-it-yourself system is so simple, a small crew of people can install a full sized field in less than a day. No special equipment. No heavy lifting.

DESIGN YOUR OWN FACILITY

Curved corners? Oddly shaped areas? No problem! We can design your custom field or court to fit your surface perfectly.

BE FLEXIBLE - GENERATE REVENUE

Convert your area from floor to field and court and back to floor to increase the use of your facility and generate revenue.

STACK 'EM UP

The EasyField panels can be easily stacked and stored to provide long-lasting portable performance. Recommendation: You can stack up to 25 EasyField panels.



EasyField panels securely connect with a simple interlocking knob system allowing for a seamless look. The innovative connectors have been tested through many removals, to give you a stable field with every installation. EasyField provides the Easylock technology.

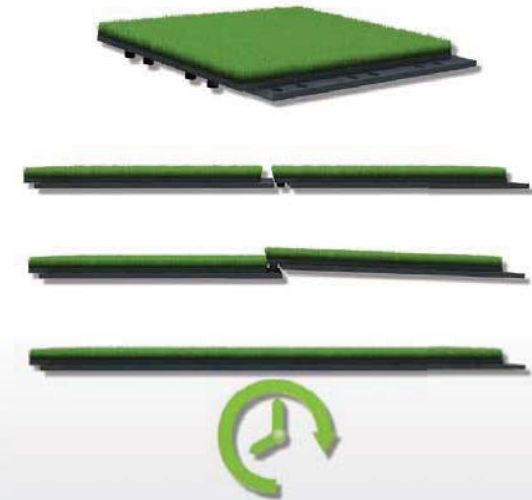

INSTALL A FIELD IN A MATTER OF HOURS



Need a safe way of walking off of EasyField? EasyEdging uses the EasyLock design to securely connect with an interlocking knob system allowing for a seamless look.





THE TARKETT SPORTS FAMILY - LEADERS IN SPORTS SURFACING



888-364-6541 | tarkettsportsindoor.com



TarkettSPORTS

DROPZONE

SUPERIOR SURFACE STRENGTH

**ATHLETES
COMMIT TO
THE GAME...
CHOOSE THE
FLOOR THAT
COMMITTS TO
THE ATHLETE**



AN INDUSTRY LEADER

Tarkett Sports is a division of the Tarkett Group, which was established in 1886. The knowledge and expertise accrued by Tarkett over 130 years has made it one of the largest flooring manufacturers in the world.

With over \$2.5 Billion in annual sales and an average of 13 million square feet of flooring produced per day, Tarkett is a global leader in commercial, residential, and sports solutions.



BUILT STRONGER, TOGETHER

Tarkett Sports does it all. We offer a full range of surfacing products. From our line of commercial, residential and athletic artificial turf, sports tracks, and indoor flooring, we have the right solution to fit your needs. Tarkett Sports is built stronger, together.



WHY TARKETT SPORTS



TARKETT SPORTS BRAND

Tarkett Sports is a world leader in athletic surfacing, offering a comprehensive portfolio of sports flooring solutions through its brands: FieldTurf, Beynon Sports, Renner Sports, EasyTurf, Desso, GrassMaster, PlayMaster and Tarkett Sports Indoor.



DESIGN & CONSTRUCTION EXPERTS

Tarkett Sports and our partners are some of the most experienced and knowledgeable teams in the industry. When it comes to the design and construction of your sports surface, we are the experts.



FINANCIALLY STABLE

The Tarkett Group is a worldwide leader of innovative flooring and sports surface solutions. Tarkett Sports Indoor is backed by unprecedented financial support and stability. You can rest easy.



LEADING DURABILITY

Manufactured and installed with the highest attention to detail, Tarkett Sports Indoor's systems showcase proven durability.



EXPERIENCE

With over 5,000 installations in North America in the last 10 years, Tarkett Sports Indoor has the knowledge and expertise to make your sports facility a success.



TRUSTED

For indoor facilities, Tarkett Sports Indoor offers the most trusted sports flooring for various style facilities in North America.



ENDLESS PURSUIT OF INNOVATION

From the Dropzone rubber, PolyTurf Pad and Pour system, Omnisports vinyl sports flooring, ClutchCourt wood, and EcoPure linoleum, our innovation and versatility extend beyond just sports. We're there to support your team.



SERVICE

We are as committed to your program as you are, and we're with you for the long term. When you buy from Tarkett Sports, you're buying from a company that knows how to take care of you.



"We went with the Droptile because the environment we're in, the abuse it takes with weights being dropped on the floor either accidentally or through some of the Olympic lifts, we wanted something that was going to hold up over time and look as good ten years from now as it did the day we installed it."

MIKE LAWRENCE
STRENGTH AND CONDITIONING COACH
JOPLIN HIGH SCHOOL, JOPLIN, MO

A TURNKEY SOLUTION

WITH TARKETT SPORTS INDOOR

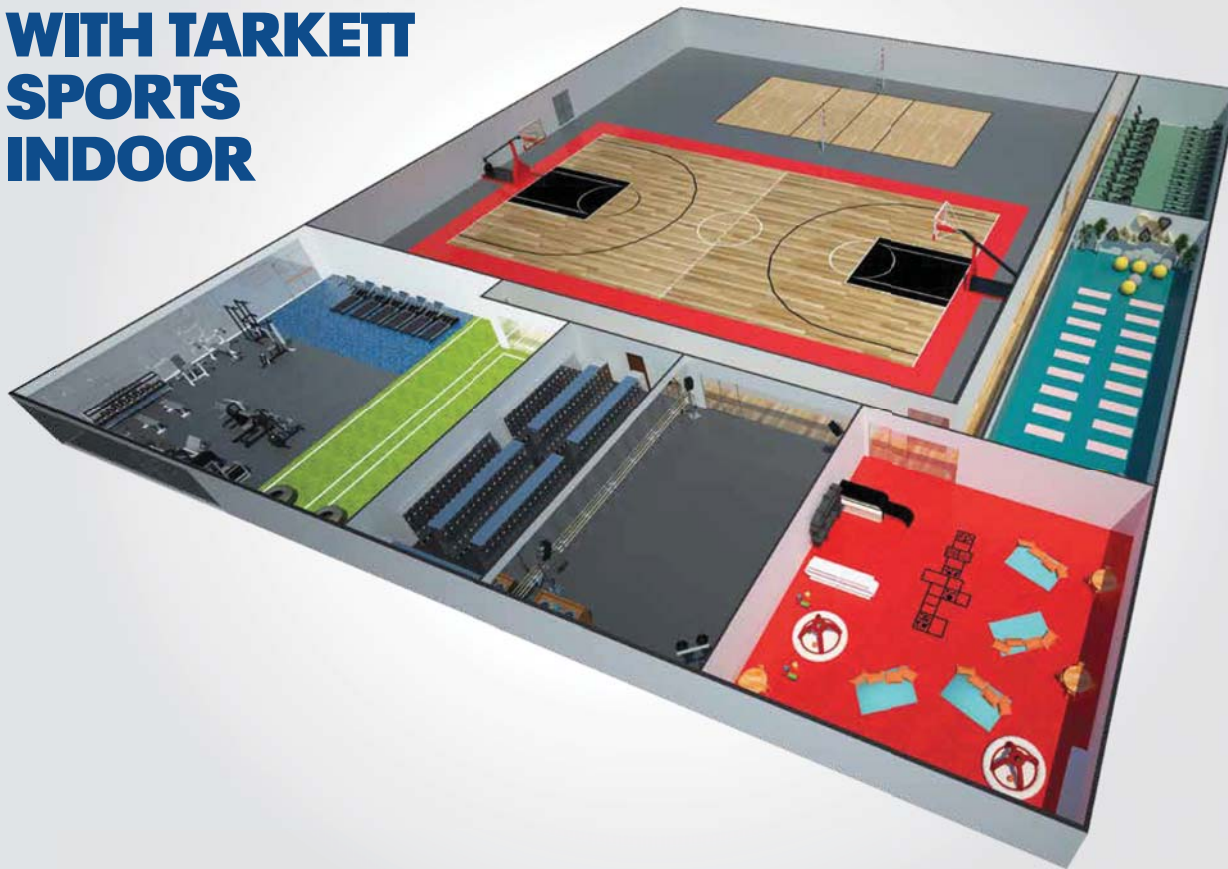

OMNISPORTS

The Game-Changing versatility of Omnisports

Applications: Gymnasium • Daycare • Multi-Purpose Rooms • Cafetorium • Yoga • Martial Arts



DROPZONE

The surface strength of Dropzone rubber flooring

Applications: Weight Rooms • Strength & Cardio Equipment • Spinning • Training Turf • Functional & Extreme Training • Ice Rinks



CLUTHCOURT

Inspiring tradition of ClutchCourt Northern Maple

Applications: Gymnasium (Basketball & Volleyball) • Aerobics • Racquetball

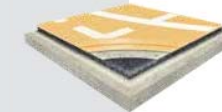

POLYTURF PLUS PAD & POUR

The durable playing surface of PolyTurf Plus Pad & Pour

Applications: Multi-Purpose Rooms • Cafetorium • Gymnasium • Inline Skating

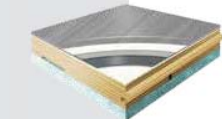

LUMAFLEX

The pinnacle of sports performance with LumaFlex

Applications: Gymnasium • Multi-Purpose Rooms • Inline Skating • Aerobic and Fitness



DANCEFLOOR

Perform at your best with Dancefloor

Applications: Dance Studio • Dance Stage

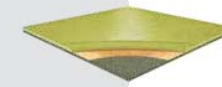

ECOPURE

The natural sustainability of EcoPure Linoleum

Applications: Multi-Purpose Rooms • Gymnasium • Daycare

RECYCLING FROM START TO FINISH

Environmental responsibility in fitness flooring is about understanding a product's complete life cycle – where it came from and where it will end up. That is why recycling is such a key concern. Dropzone Speckle is one of those unique floors that begins and ends its life with recycling. It incorporates from 70% to 90% total recycled content depending on color, most of which is post-consumer material such as old automobile tires.

Dropzone and Dropzone Comfort contain, on average, approximately 62% of post-consumer recycled content. Most importantly, Tarkett's Dropzone flooring can be recycled at the end of its life, diverting waste from landfills and creating new material for the manufacture of other products. (Post-Consumer recycled content will vary depending upon the construction of the product).



HEALTH AND THE ENVIRONMENT

Dropzone embodies four categories of Tarkett's sustainability, providing not only superior performance, but stewardship of the environment and care for individual health.



FLOORSCORE CERTIFIED

With FloorScore® certification for indoor air quality and low VOC emissions, Dropzone also helps create a healthier workout environment.

LOW VOCs AND BETTER INDOOR AIR QUALITY

A healthy indoor environment begins with low levels of volatile organic compounds (VOCs).

▶ VOC EMISSIONS LESS THAN 10 MICROGRAMS PER CUBIC METER*

A lower VOC emission rate than most other resilient sports floors

*VOCs after 28 days (ISO 16000)

▶ COMPLIES WITH CALIFORNIA SECTION 01350, THE MOST STRINGENT AIR QUALITY REGULATION IN THE U.S.



The **mindful MATERIALS** Library is a searchable database where users can find architectural building products that have various transparency and sustainability attributes. You can now find numerous Tarkett Sports' products in the **mindful MATERIALS** Library.



MANUFACTURED IN AMERICA

.....

All aspects of the manufacturing chain are performed in America. This allows us to create the right product with the highest quality for your facility. We proudly stand behind our products and take special care throughout the entire manufacturing process.



DESIGN

We design products that are built strong and to last long. The variety and design of the Dropzone products are created to facilitate the needs of our customers.



FORMULATION

Our philosophy on materials selection is simple: use only the best environmentally friendly, bio-based raw materials because we understand that the material choices we make today will affect your athletes for years to come.



MANUFACTURING

Dropzone is manufactured in the United States. We ensure the highest level of quality and consistency in production.



INSTALLATION

Dropzone products are offered in various format options and can be installed and ready to use in a relatively short time frame.

DROPZONE

FOR GAME DAY
OR ANY DAY

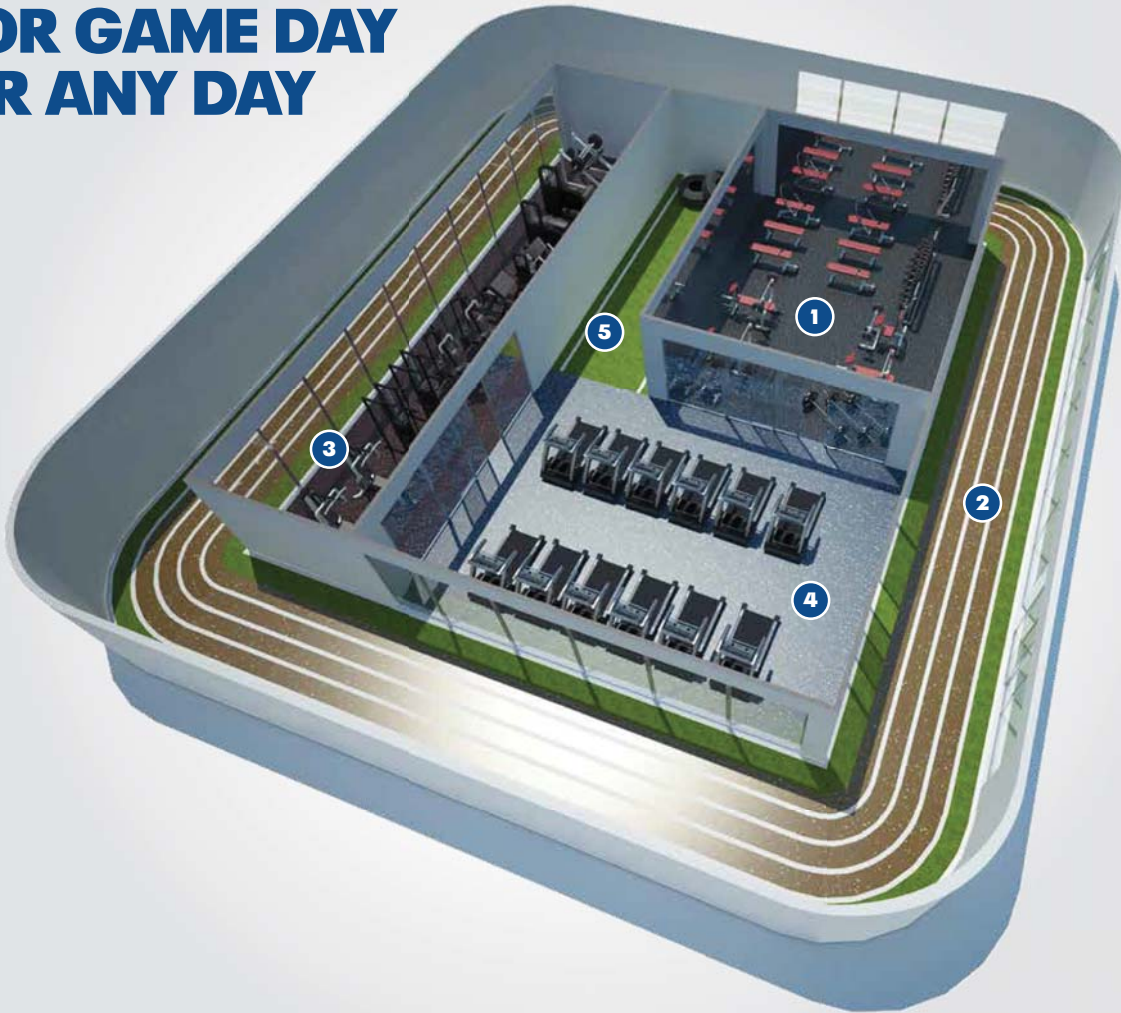

1

FREE WEIGHT ROOM

DROPTILE (PAGE 24-25)

Alternatives: Dropzone Flex, Dropzone Impact, Dropzone, Dropzone Speckle, Dropzone Comfort, Dropzone Elite, DropTile Max

2

WALKING OR JOGGING TRACK

DROPZONE COMFORT (PAGE 28-29)

Alternatives: Dropzone Elite

3

FUNCTIONAL & EXTREME TRAINING

DROPZONE ELITE (PAGE 30-31)

Alternatives: Dropzone Flex, Dropzone Impact, Dropzone Elite, Dropzone Comfort, DropTile Max, DropTurf

4

CARDIO EQUIPMENT

DROPZONE SPECKLE (PAGE 26-27)

Alternatives: Dropzone, Dropzone Comfort, Dropzone Elite, DropTile, DropTile Max

5

TRAINING TURF APPLICATIONS

DROPTURF (PAGE 36-37)

VULCANIZED CALENDERED RUBBER

DROPZONE IMPACT

(PAGE 18-19)

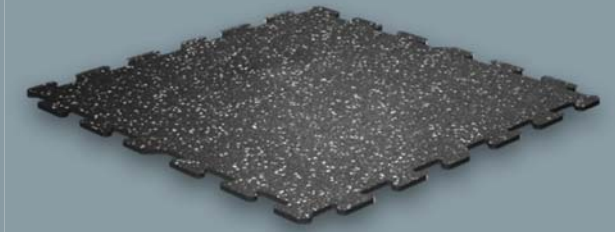

DROPZONE FLEX

(PAGE 20-21)



.....

Whatever you're looking to accomplish in a floor, rubber has a solution. Safe, comfortable, sustainable—and full of possibility—Tarkett Sports Indoor's Vulcanized Calendered Rubber offers an unmatched variety of colors, patterns and textures, and no need for dye lots. With natural slip resistance, shock absorption, and comfortable acoustics, rubber just seems to check all the boxes.

DROPZONE IMPACT



8 YEAR
PRODUCT WARRANTY

DROPZONE IMPACT is constructed of vulcanized rubber with a speckled surface design, which is built tough, flexible and performance-ready. This floor is engineered to hold up under constant traffic, sports activities and heavy sporting equipment. Made of 10 mm thick rubber, Dropzone Impact absorbs noise and resists impact, shock, spikes and skates.

FORMAT OPTIONS



STRAIGHT EDGE TILES
24" (61cm) x 24" (61cm)



INTERLOCKING RUBBER
23" (58cm) x 23" (58cm)

APPLICATIONS



CARDIO



LIGHT
WEIGHTS



MODERATE
WEIGHTS



EXTREME
FUNCTIONAL
TRAINING



STRENGTH
EQUIPMENT



ICE RINKS

BENEFITS

ENHANCED DURABILITY AND FLEXIBILITY

Dropzone Impact rubber flooring brings enhanced durability, flexibility, safety and performance to the forefront in gyms, ice rinks and more.

ENGINEERED TO PERFORM

Dropzone Impact is engineered to perform under the most brutal conditions. This spike- and skate-resistant rubber tile can withstand extreme sporting activities, constant foot traffic and heavy rolling and static loads.

CONSISTENT COLOR

Dropzone Impact comes with a high tolerance for color consistency and has no dye lots.

COLOR SELECTION

Dropzone Impact comes with **12 color options**, which makes it easy to create unique gym floors or match the colors of a school or team.



DROPZONE FLEX



8 YEAR
PRODUCT WARRANTY

DROPZONE FLEX is constructed of vulcanized rubber with a marbled surface design, which is built tough, flexible and performance-ready. This floor is engineered to hold up under constant traffic, sports activities and heavy sporting equipment. Made of 10 mm thick rubber, Dropzone Flex absorbs noise and resists impact, shock, spikes and skates.

FORMAT OPTIONS



STRAIGHT EDGE TILES
24" (61cm) x 24" (61cm)



INTERLOCKING RUBBER
23" (58cm) x 23" (58cm)

APPLICATIONS



CARDIO



LIGHT WEIGHTS



MODERATE WEIGHTS



EXTREME FUNCTIONAL TRAINING



STRENGTH EQUIPMENT



ICE RINKS

BENEFITS

ENHANCED DURABILITY AND FLEXIBILITY

Dropzone Flex rubber flooring brings enhanced durability, flexibility, safety and performance to the forefront in gyms, ice rinks and more.

ENGINEERED TO PERFORM

Dropzone Flex is engineered to perform under the most brutal conditions. This spike- and skate-resistant rubber tile can withstand extreme sporting activities, constant foot traffic and heavy rolling and static loads.

CONSISTENT COLOR

Dropzone Flex comes with a high tolerance for color consistency and has no dye lots.

COLOR SELECTION

Dropzone Flex comes with **8 color options**, which makes it easy to create unique gym floors or match the colors of a school or team.



VULCANIZED COMPOSITION RUBBER

DROPTILE

(PAGE 24-25)

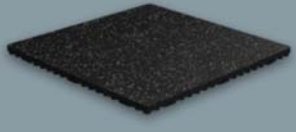

DROPZONE SPECKLE

(PAGE 26-27)



DROPZONE COMFORT

(PAGE 28-29)

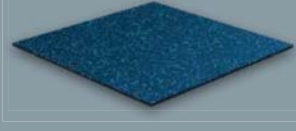

DROPZONE ELITE

(PAGE 30-31)

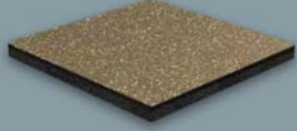

DROPTILE MAX

(PAGE 32-33)



.....

We pride ourselves on transforming reclaimed materials into unique performance surfacing. Tarkett Sports knows how to make recycled rubber perform better and adapt it for new uses. With the Vulcanized Composition Rubber, Tarkett Sports Indoor creates a whole new flooring category of truly sustainable products.

DROPTILE



15 YEAR
PRODUCT WARRANTY

DROPTILE is a one-inch thick tile that provides supreme durability and maximum vibration absorption. It provides the perfect level of support for weights and equipment without showing signs of wear. The elevated profile of Droptile's subsurface allows wires and cables to be fully integrated beneath the surface, preventing cable clutter. These 24" x 24" x 1" rubber floor tiles lock together using our Quad Blok system.

FORMAT OPTIONS



STRAIGHT EDGE TILES
1" x 24" (61cm) x 24" (61cm)

APPLICATIONS



STRENGTH
EQUIPMENT



LIGHT
WEIGHTS



MODERATE
WEIGHTS



EXTREME
WEIGHTS

COLOR SELECTION

Droptile comes with **16 color options**, which makes it easy to create unique gym flooring or match the colors of a school or team.

BENEFITS

HEALTHIER INDOOR AIR QUALITY

Droptile is FloorScore® certified by SCS Global Services. This certification indicates exceptionally low VOC emissions.

NO "CABLE CLUTTER"

The elevated subsurface of Droptile rubber floor tiles allows cables and wires to be incorporated underneath the surface, reducing tripping hazards and "cable clutter."

ADDED COMFORT AND REDUCED VIBRATION

Droptile's one-inch thick surface reduces vibrations caused by the impact of weights while improving comfort under foot.

QUAD BLOK CONNECTOR SYSTEM

Each Droptile is connected using a Quad Blok connector system, fastening each tile together. Since Droptile has a 1" thickness, reducers are used on the edges of the installation to transition to lower profile areas. Glue is used to provide adhesion from the Blok to the tile.

TARKETT SPORTS WARRANTY PROTECTION

The quality and performance of Droptile is protected by Tarkett Sports with a comprehensive 15-year warranty.

DROPZONE SPECKLE



3 YEAR
PRODUCT WARRANTY

DROPZONE SPECKLE offers the same weight room flooring protection as Tarkett Sports' Dropzone with the addition of color. Blending recycled rubber with colored EPDM rubber chips, Dropzone Speckle offers a wide variety of color options. No matter the format you choose, the surface appearance of Dropzone Speckle hides seams, creating the look of continuous rubber flooring.

FORMAT OPTIONS

Roll goods are available in 6mm and 8 mm thicknesses. Straight edge tiles and interlocking tiles are available in an 8 mm thickness.



ROLLS

6mm x 48" (1.2m)
8mm x 48" (1.2m)



STRAIGHT EDGE TILES

8mm x 24" (61cm) x 24" (61cm)

**Must be purchased in full cylinder increments.*



INTERLOCKING TILES

8mm x 23" (58cm) x 23" (58cm)

APPLICATIONS



CARDIO



LIGHT WEIGHTS



ICE RINKS



STRENGTH
EQUIPMENT

BENEFITS

SPORTS PERFORMANCE

Dropzone embodies the characteristics that make quality weight room flooring:

- Excellent tensile strength (200 psi – ASTM D412)
- Static load tolerance (400 psi – ASTM F970) impact insulation (54 – ASTM E492)
- Sound transmission (54 – ASTM E413).

HEALTHIER INDOOR AIR QUALITY

Dropzone Speckle is FloorScore® certified by SCS Global Services. This certification indicate exceptionally low VOC emissions.

TARKETT SPORTS WARRANTY PROTECTION

Tarkett Sports guarantees the quality and performance of Dropzone Speckle with a comprehensive 3-year warranty.

COLOR SELECTION

Dropzone Speckle comes with **23 color options**, which makes it easy to create unique gym flooring or match the colors of a school or team.

DROPZONE COMFORT

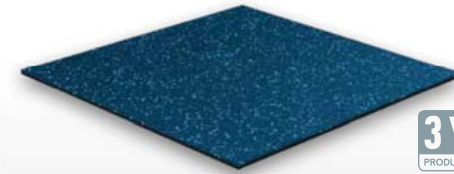
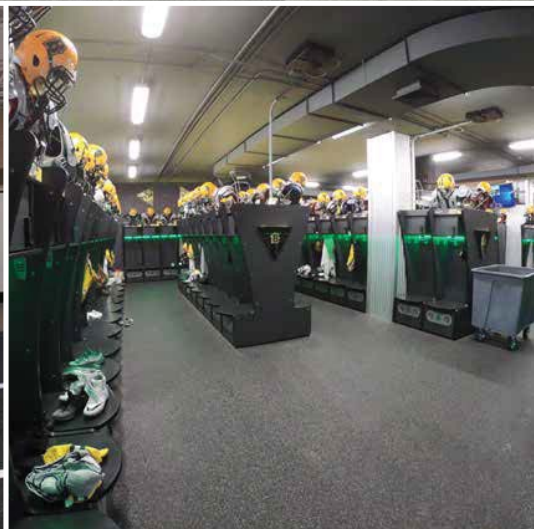

3 YEAR
PRODUCT WARRANTY

DROPZONE COMFORT is a premium fitness flooring option with performance characteristics that are ideal for exercise areas, noncompetitive walking/jogging tracks, and weight rooms. It has shock absorption properties that are uncommon among flooring designed for fitness and weight room applications. This helps reduce strain on lower extremities and increases the level of comfort for the user. Dropzone Comfort also has excellent resistance to color fading and wear, making it a durable surface that can withstand heavy traffic.

FORMAT OPTIONS



ROLLS
14.5mm (2.5mm+12mm) x 48" (1.2m)
10.5mm (2.5mm+8mm) x 48" (1.2m)

APPLICATIONS 14.5mm



CARDIO



LIGHT WEIGHTS



MODERATE WEIGHTS



EXTREME FUNCTIONAL TRAINING



TRACK



STRENGTH EQUIPMENT



FUNCTIONAL TRAINING

APPLICATIONS 10.5mm



CARDIO



LIGHT WEIGHTS



MODERATE WEIGHTS



EXTREME WEIGHTS

BENEFITS

SPORTS PERFORMANCE

Dropzone Comfort has some unique performance properties compared to other recycled rubber floors. It has shock absorption values that provides excellent comfort and reduces strain on lower extremities.

RECYCLED CONTENT

Dropzone Comfort contains between 67% and 90% recycled content depending on color, most of which is post-consumer materials such as used automobile tires.

TARKETT SPORTS WARRANTY PROTECTION

Tarkett Sports guarantees the quality and performance of Dropzone Comfort with a comprehensive 3-year warranty.

COLOR SELECTION

Dropzone Comfort comes with **13 color options**, which makes it easy to create unique gym flooring or match the colors of a school or team.

DROPZONE ELITE

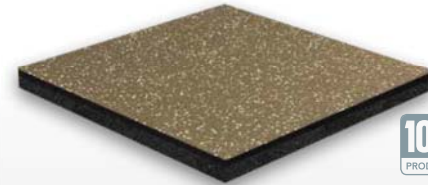

10 YEAR
PRODUCT WARRANTY

DROPZONE ELITE is an optimal weight room flooring option that provides extreme comfort and safety. This system features a 10.5mm Dropzone Comfort field united to a 12 mm cushion. The resulting double durometer system combines the durability and firm footing desired in strength training with the ergonomic demands of aggressive functional training in one surface.

FORMAT OPTIONS



ROLLS
22.5mm x 48" (1.2m)

APPLICATIONS



CARDIO



LIGHT
WEIGHTS



MODERATE
WEIGHTS



EXTREME
WEIGHTS



STRENGTH
EQUIPMENT



FUNCTIONAL
TRAINING



EXTREME
FUNCTIONAL
TRAINING

BENEFITS

SPORTS PERFORMANCE

Dropzone Elite has some unique performance properties compared to other recycled rubber floors. It has shock absorption values that provides excellent comfort and reduces strain on lower extremities but also combines the durability and firm footing desired in strength training with the ergonomic demands of aggressive functional training in one surface.

RECYCLED CONTENT

Dropzone Comfort contains between 82% and 90% recycled content depending on color, most of which is post-consumer materials such as used automobile tires.

TARKETT SPORTS WARRANTY PROTECTION

Tarkett Sports guarantees the quality and performance of Dropzone Elite with a comprehensive 3-year warranty.

COLOR SELECTION

Dropzone Comfort comes with **13 color options**, which makes it easy to create unique gym flooring or match the colors of a school or team.

DROPTILE MAX



5 YEAR
PRODUCT WARRANTY

DROPTILE MAX is a unique rubber floor that is perfect for accommodating heavy exercise equipment and weights. These 2-foot by 2-foot by 2.5-inch molded tiles lock together using our Quad Blok system. Droptile Max's unique elevated subsurface also provides space for wiring and cables, which helps prevent a cluttered exercise environment.

FORMAT OPTIONS



STRAIGHT EDGE TILES
2.5" x 24" (61cm) x 24" (61cm)

APPLICATIONS



STRENGTH
EQUIPMENT



LIGHT
WEIGHTS



MODERATE
WEIGHTS



EXTREME
WEIGHTS

COLOR SELECTION

Droptile Max comes with **17 color options**, which makes it easy to create unique gym flooring or match the colors of a school or team.

BENEFITS

HEALTHIER INDOOR AIR QUALITY

Droptile Max is FloorScore® certified by SCS Global Services. This certification indicates exceptionally low VOC emissions.

NO "CABLE CLUTTER"

The elevated subsurface of Droptile Max rubber floor tiles allows cables and wires to be incorporated underneath the surface, reducing tripping hazards and "cable clutter."

ADDED COMFORT AND REDUCED VIBRATION

Droptile Max's 2.5 inch thick surface mitigates the shock and sound resulting from weights being released onto its surface by absorbing impact.

QUAD BLOK CONNECTOR SYSTEM

Each Droptile Max is connected using a Quad Blok connector system, fastening each tile together. Since Droptile Max has a 2.5" thickness, reducers are used on the edges of the installation to transition to lower profile areas. Glue is used to provide adhesion from the Blok to the tile.

TARKETT SPORTS WARRANTY PROTECTION

The quality and performance of Droptile Max is protected by Tarkett Sports with a comprehensive 15-year warranty.



TURF DROPZONE PRODUCT

DROPTURF

(PAGE 36-37)



DropTurf is a durable product that has been designed and engineered in the USA for indoor use. Applications include: CrossFit, functional training and extreme functional training and much more.

DROPTURF



DROPTURF features a 40 oz. textured polyethylene that offers excellent ball roll. DropTurf provides a much less abrasive surface than nylon or polypropylene and provides superior wear resistance. DropTurf is 19 mm thick, combining the 14 mm polyethylene turf with a 5 mm foam backing, providing superior safety and performance. Thicker backing options are available via custom order.

FORMAT OPTIONS



ROLLS
15' wide, custom length

APPLICATIONS



TURF/FIELDS



FUNCTIONAL TRAINING



EXTREME FUNCTIONAL TRAINING



BENEFITS

IDEAL FOR VARIOUS APPLICATIONS

DropTurf is ideal for indoor soccer, specialty sports training facilities, CrossFit centers, and more.

ACCOMMODATES A LARGER NUMBER OF SPORTS AND ACTIVITIES

It comes standard in a blend color, in 15 foot widths and a 5mm foam backing

CUSTOM DESIGN POSSIBILITIES

Our exclusive water jet cutting system smoothly cuts some of the world's most sophisticated and beautiful turf designs. The end result is unrivaled detail, large color palettes, and the capability to create complex projects.

TARKETT SPORTS WARRANTY PROTECTION

The quality and performance of DropTurf is protected by Tarkett Sports with a comprehensive 8-year warranty.

COLOR SELECTION

DropTurf comes with **12 color options**, which makes it easy to create unique indoor designs or match the colors of a school or team. Other colors are available via custom order.



**TEAM UP WITH
DROPZONE
TO BRING
YOUR GAME
TO ANOTHER
LEVEL**



THE TARKETT SPORTS FAMILY - LEADERS IN SPORTS SURFACING



888-364-6541 | tarkettsportsindoor.com



TarkettSPORTS

LUMAFLEX

CREATING A NEW TRADITION

**TAKE YOUR
GAME TO
ANOTHER
LEVEL...
LITERALLY**



AN INDUSTRY LEADER

Tarkett Sports is a division of the Tarkett Group, which was established in 1886. The knowledge and expertise accrued by Tarkett over 130 years has made it one of the largest flooring manufacturers in the world.

With over \$2.5 Billion in annual sales and an average of 13 million square feet of flooring produced per day, Tarkett is a global leader in commercial, residential, and sports solutions.



BUILT STRONGER, TOGETHER

Tarkett Sports does it all. We offer a full range of surfacing products. From our line of commercial, residential and athletic artificial turf, sports tracks, and indoor flooring, we have the right solution to fit your needs. Tarkett Sports is built stronger, together.



WHY TARKETT SPORTS



TARKETT SPORTS BRAND

Tarkett Sports is a world leader in athletic surfacing, offering a comprehensive portfolio of sports flooring solutions through its brands: FieldTurf, Beynon Sports, Renner Sports, EasyTurf, Desso, GrassMaster, PlayMaster and Tarkett Sports Indoor.



DESIGN & CONSTRUCTION EXPERTS

Tarkett Sports and our partners are some of the most experienced and knowledgeable teams in the industry. When it comes to the design and construction of your sports surface, we are the experts.



FINANCIALLY STABLE

The Tarkett Group is a worldwide leader of innovative flooring and sports surface solutions. Tarkett Sports Indoor is backed by unprecedented financial support and stability. You can rest easy.



LEADING DURABILITY

Manufactured and installed with the highest attention to detail, Tarkett Sports Indoor's systems showcase proven durability.



EXPERIENCE

With over 5,000 installations in North America in the last 10 years, Tarkett Sports Indoor has the knowledge and expertise to make your sports facility a success.



TRUSTED

For indoor facilities, Tarkett Sports Indoor offers the most trusted sports flooring for various style facilities in North America.



ENDLESS PURSUIT OF INNOVATION

From the Dropzone rubber, PolyTurf Pad and Pour system, Omnisports vinyl sports flooring, ClutchCourt wood, and EcoPure linoleum, our innovation and versatility extend beyond just sports. We're there to support your team.



SERVICE

We are as committed to your program as you are, and we're with you for the long term. When you buy from Tarkett Sports, you're buying from a company that knows how to take care of you.



A TURNKEY SOLUTION

WITH TARKETT SPORTS INDOOR

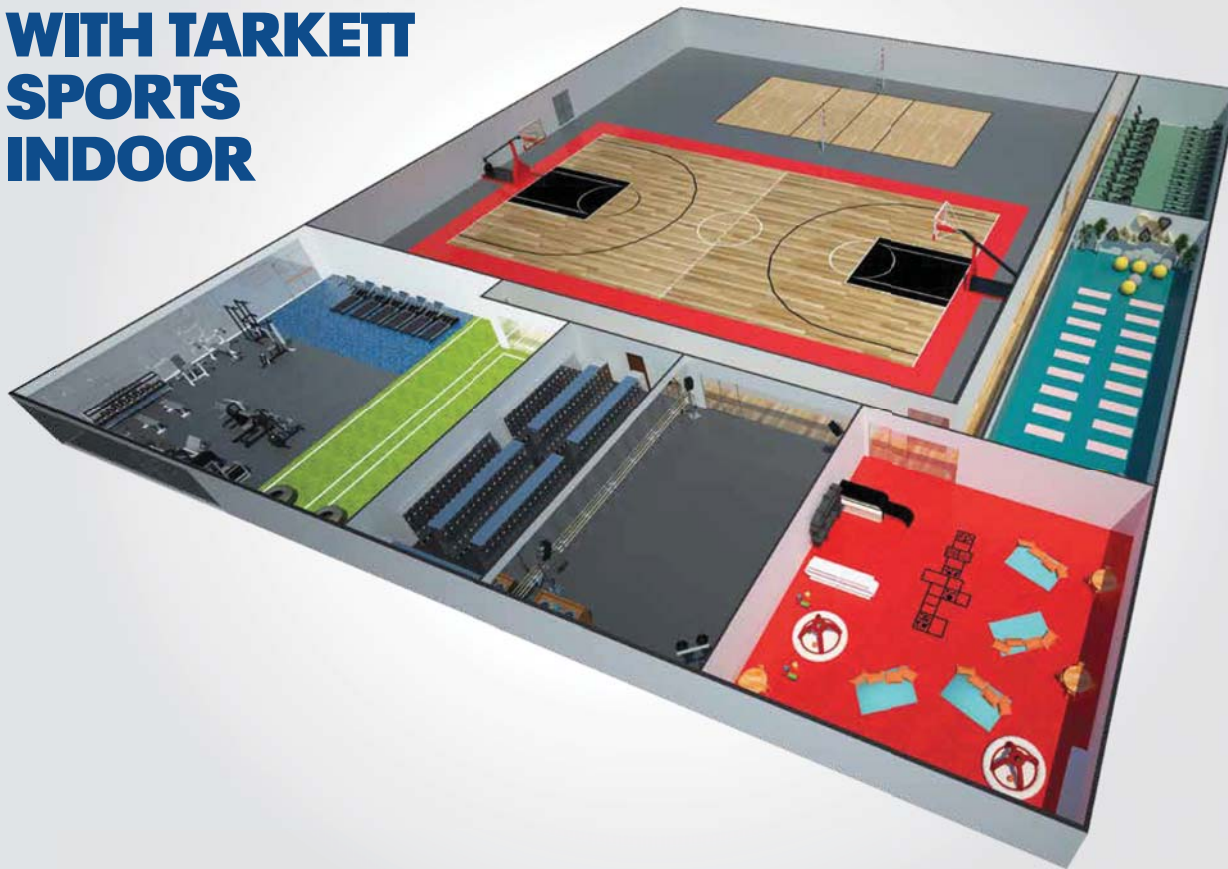

OMNISPORTS

The Game-Changing versatility of Omnisports

Applications: Gymnasium • Daycare • Multi-Purpose Rooms • Cafetorium • Yoga • Martial Arts



DROPZONE

The surface strength of Dropzone rubber flooring

Applications: Weight Rooms • Strength & Cardio Equipment • Spinning • Training Turf • Functional & Extreme Training • Ice Rinks



CLUTHCOURT

Inspiring tradition of ClutchCourt Northern Maple

Applications: Gymnasium (Basketball & Volleyball) • Aerobics • Racquetball

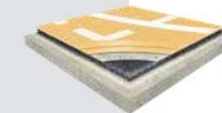

POLYTURF PLUS PAD & POUR

The durable playing surface of PolyTurf Plus Pad & Pour

Applications: Multi-Purpose Rooms • Cafetorium • Gymnasium • Inline Skating

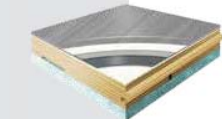

LUMAFLEX

The pinnacle of sports performance with Lumaflex

Applications: Gymnasium • Multi-Purpose Rooms • Inline Skating • Aerobic and Fitness



DANCEFLOOR

Perform at your best with Dancefloor

Applications: Dance Studio • Dance Stage

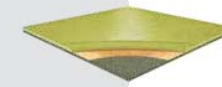

ECOPURE

The natural sustainability of EcoPure Linoleum

Applications: Multi-Purpose Rooms • Gymnasium • Daycare

A HEALTHY ATHLETE IS A BETTER ATHLETE

A HEALTHY SPORTS SURFACE IS A BETTER SPORTS SURFACE

Omnisports with Lumaflex comes with a Material Health Statement (MHS) from the Environmental Protection Encouragement Agency (EPEA), a science-based, third-party verified product ingredient disclosure. An MHS provides full ingredient disclosure to 100 parts per million, and assesses ingredient impacts on extraction, production, use and recycling. Tarkett Sports is the only sports floor manufacturer to receive a Material Health Statement (MHS).

"We've also hosted the Harlem Wizards, which is a farm team of the Harlem Globetrotters and we had an event here where they played a faculty and parent team to open our new gym. Judging by the way they dunked the ball, the flooring system works magnificent. We've also been able to host our graduation in here. So in other words, we were able to insure that the flooring can provide sports, but also any other events that a school might want to use in a gymnasium..."

BRYAN NIXON
HEAD OF SCHOOL, WHITBY SCHOOL
GREENWICH, CONNECTICUT



HEALTH AND THE ENVIRONMENT

Lumaflex embodies four categories of Tarkett's sustainability, providing not only superior performance, but stewardship of the environment and care for individual health.



FLOORSCORE CERTIFIED

With FloorScore® certification for indoor air quality and low VOC emissions, Lumaflex also helps create a healthier workout environment.

LOW VOCs AND BETTER INDOOR AIR QUALITY

A healthy indoor environment begins with low levels of volatile organic compounds (VOCs).

▶ VOC EMISSIONS LESS THAN 10 MICROGRAMS PER CUBIC METER*

A lower VOC emission rate than most other resilient sports floors

*VOCs after 28 days (ISO 16000)

▶ COMPLIES WITH CALIFORNIA SECTION 01350, THE MOST STRINGENT AIR QUALITY REGULATION IN THE U.S.



The **mindful MATERIALS** Library is a searchable database where users can find architectural building products that have various transparency and sustainability attributes. You can now find numerous Tarkett Sports' products in the **mindful MATERIALS** Library.

CREATE A NEW TRADITION

HAVE YOU EVER DREAMED OF A SPORTS FLOOR THAT PERFORMS LIKE HARDWOOD MAPLE BUT HAS A MULTIPURPOSE ADVANTAGE?



WITH LUMAFLEX, YOU CAN TURN YOUR DREAM INTO A REALITY!

A Lumaflex system meets or exceeds the sports performance of many MFMA PUR Compliant traditional maple sports flooring systems.

IS IT THE TRADITIONAL WOOD DESIGN THAT INTRIGUES YOU?

When you pair a Lumaflex system with Tarkett Sports' Omnisports flooring, you have numerous woodgrain design and color options.





CHOOSE LUMAFLEX

FOR A LONG-TERM INVESTMENT WITH LONG-TERM GAINS

Your combination system is more than a high performance surface; it is also a multipurpose floor with unlimited possibilities and benefits. There's no need for a floor cover because a Lumaflex system – combined with an Omnisports, EcoPure, or PolyTurf Plus surface – is extremely durable.

The versatility of Lumaflex extends beyond just sports. It can accommodate tables and chairs, or portable stages for events like conferences and assemblies. This makes Lumaflex the perfect gym floor for non-sports applications, such as graduation ceremonies, dances, banquets, trade shows, and much more.

With the ability to hold events, the multipurpose advantage of Lumaflex is an investment that will lead to long-term gains.

LOWER LIFE CYCLE COSTS WITH LUMAFLEX

The factory engineered 18-ply birch wood subfloor is up to 75% more stable than solid maple. With the Lumaflex system's vapor barrier, the system can withstand concrete moisture. Because this is a very highly plied engineered system, expansion requirements typical for wood flooring systems are reduced.

A Lumaflex system can correct the profile difference of a recessed slab with shock absorbing foam, giving you a top-tier system with the low maintenance and versatility of a resilient sports surface.

Overall, a Lumaflex system's life cycle costs can be lower than standard hardwood floors due to the elimination of annual maintenance requirements, such as screening and recoating the top coat and full sanding and refinish every 10 to 20 years.

SIMPLIFIED MAINTENANCE

BECAUSE HARDWOOD MAPLE IS POROUS AND NATURALLY ABSORBS AND RELEASES MOISTURE, IT DEMANDS AN ADDITIONAL MEASURE OF CARE. WHEN CHOOSING OMNISPORTS, POLYTURF PLUS PAD AND POUR OR ECOPURE WITH YOUR LUMAFLEX SYSTEM, IT'S QUITE THE OPPOSITE.

OMNISPORTS

Omnisports' TopClean xp™ surface treatment protects against scratches and aids the removal of sole marks. It also allows the floor to transition between sports and non-sporting events without the need for a protective covering. This provides easier maintenance, with much less effort. No need to wax. Just sweep, wash and rinse.

POLYTURF PLUS PAD & POUR

The primary characteristic of PolyTurf Plus Pad and Pour is its seamless playing surface. It also comes with a water-based aliphatic coating. This spray or roller-applied coating provides optimal game performance, stain resistance and easier maintenance.

ECOPURE

The second-generation xf2™ surface allows Tarkett's linoleum to withstand heavy traffic with minimal maintenance requirements. It NEVER requires waxing or refinishing.



A MULTI- PURPOSE FLOOR WITH EXTREME SPORTS PERFORMANCE



COMFORT & SAFETY

AREA-ELASTIC



Area-elastic floors disperse downward force over a wide surface area, engaging more of the surface area in returning energy to the athlete. They are mostly synonymous with wood flooring.

POINT-ELASTIC



The area of deformation on point-elastic flooring is much smaller than area-elastic systems; the surrounding areas of the floor remain relatively unchanged by activity in a particular area.

COMBI-ELASTIC SYSTEM

By engaging both types of elasticity, all Lumaflex systems respond to impact both locally and across the wider surface area. As a result of this dual response, they are widely regarded as one of the best sports floors for comfort, safety, and sports performance.



THE PERFECT COMBINATION

All Lumaflex systems combine point-elastic surface properties with an area-elastic substructure. This gives athletes significantly more comfort, thanks to great vertical deformation and cushioning, that they wouldn't experience with a basic area-elastic hardwood floor.



ASTM F2772

THE SPORTS FLOORING STANDARD

In areas designated for sports, flooring should be optimized for physical activity. ASTM F2772 measures four key factors regarding safety and suitability for sports activities:

- Force Reduction
- Ball Rebound
- Surface Finish Effect
- Vertical Deformation

FORCE REDUCTION (SHOCK ABSORPTION)

ASTM F2772 separates degrees of force reduction into five classes to assist in determining the appropriate level for specific sports or other activities. ASTM F2772 also establishes a minimum value of 10% force reduction for any floor space designed for indoor athletics or physical recreation.

A COMBINATION OF SAFETY, COMFORT & SPORTS PERFORMANCE

Lumaflex is the definitive sports floor for comfort, safety, and sports performance. This combined response generates remarkably high levels of shock absorption and natural stability underfoot. On a Lumaflex floor, you can train, practice, and play for longer periods of time with less fatigue and more comfort. Combination systems, like Lumaflex, interact with athletes at the local area of impact and across the wider surface, allowing higher levels of shock absorption.



Force reduction is tested according to ASTM F2569 and indicates the degree of attenuation provided by the surface in response to certain movements. Since there is little perceivable difference between each percentage point, force reduction is expressed in 5 classes, defining a relevant range of values.

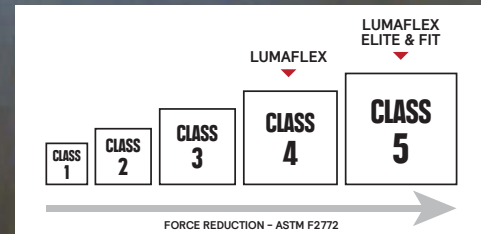

ASTM F2772

**LUMAFLEX
ANSWERS
ALL THESE
CONCERNS**

FORCE REDUCTION
REDUCES STRAIN
ON LOWER EXTREMITIES

UNIFORM
BALL REBOUND
CREATES
CONSISTENT
GAME PLAY

PROPER SURFACE
FINISH EFFECT
AND VERTICAL
DEFORMATION
MINIMIZES
SLIPPING AND
STUMBLING

LUMAFLEX SPORTS

BENEFITS

- ▶ Certified per the ASTM F2772 indoor sports flooring standard
- ▶ Very good for Point Load Stress Impact
- ▶ Outstanding playability and performance for multiple sport activities
- ▶ Competition-Level Volleyball and Basketball (Lumaflex and Lumaflex Elite)
- ▶ High-end fitness and aerobic floor (Lumaflex Fit)
- ▶ Consistent ball bounce across the entire surface
- ▶ Comfort and high sports performance thanks to the combination of a point elastic surface with an area-elastic subfloor
- ▶ A Lumaflex system does not need to be anchored
- ▶ With a Lumaflex system you can apply blocking to manage bleacher loads and portable equipment

SUPERIOR SHOCK ABSORPTION

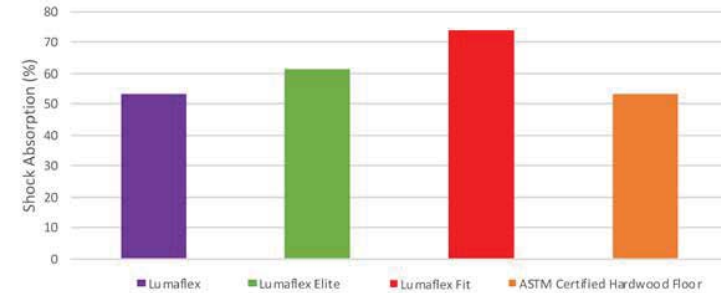

LUMAFLEX

53%

OF SHOCK ABSORPTION
ACROSS ENTIRE FACILITY

LUMAFLEX ELITE

61%

OF SHOCK ABSORPTION
ACROSS ENTIRE FACILITY

LUMAFLEX FIT

74%

OF SHOCK ABSORPTION
ACROSS ENTIRE FACILITY



COMFORT & SAFETY

LUMAFLEX GIVES ATHLETES SIGNIFICANTLY MORE COMFORT THANKS TO GREATER VERTICAL DEFORMATION AND CUSHIONING

INTRODUCING THE LUMAFLEX SYSTEMS

LUMAFLEX

Lumaflex is a Class 4, high performing competitive gym flooring solution that provides an unparalleled combination of deformation, performance, safety and comfort. By adding an area-elastic birch plywood sub-system to a point-elastic surface, Lumaflex provides the athlete with the best of both worlds.

Resilient Point-Elastic Surface:

Lumaflex can be used with a variety of Tarkett Sports' gym flooring options, including Omnisports, EcoPure and PolyTurf Plus Pad and Pour.

Lumaflex Shock-Absorbing Foam:

The Lumaflex shock-absorbing foam can be modified to accommodate different slab depressions. In addition to providing high levels of shock absorption, it is also GREENGUARD Gold certified as a low-emitting interior building material.

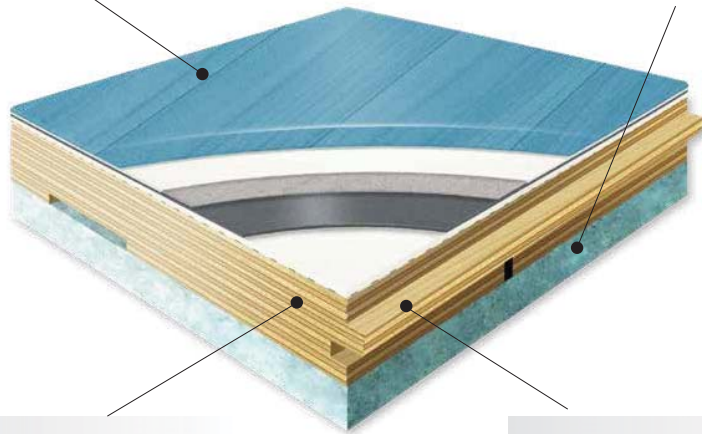

Uniform Structural Support:

These 18 mm birch plywood planks provide stability and a uniform structure for resilient sports surfaces. They are made exclusively from birch, one of the most stable species of wood.

Reliable Bonding and Assembly:

Each birch plywood plank incorporates an off-set, interlocking tongue-and-groove edge that is glued using Tarkett's specifically designed application nozzle. This allows fast and reliable installation.

TARKETT SPORTS LUMAFLEX PRODUCTS

ECOPURE LUMAFLEX



APPLICATIONS

- School Gymnasiums
- High Schools
- Colleges and Universities
- Wood Floor renovation
- Fitness/Aerobic

SURFACE LAYER OPTIONS

- EcoPure 3.2 mm

COLOR OPTIONS

- 8 color options

WARRANTY

- EcoPure is backed by an 8-year warranty

OMNISPORTS LUMAFLEX

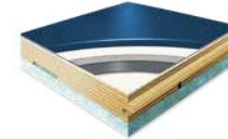

APPLICATIONS

- High-level Sports/Fitness Facilities
- Competitive Courts
- Dedicated Basketball or Volleyball Courts
- Wood floor renovation
- Aerobics Areas

SURFACE LAYER OPTIONS

- Omnisports Compact, 3.5 mm, 5.5 mm, 7.1 mm and 9.4 mm

COLOR OPTIONS

- Color options depend on Omnisports surface layer chosen

WARRANTY

- Omnisports is backed by a 15-year warranty

POLYTURF PLUS PAD & POUR LUMAFLEX

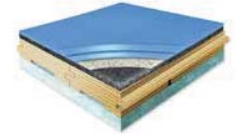

APPLICATIONS

- School Gymnasiums
- High Schools
- Colleges and Universities
- Wood Floor renovation
- Fitness/Aerobic

SURFACE LAYER OPTIONS

- PolyTurf Plus 4+2, PolyTurf Plus 7+2, PolyTurf Plus 9+2

COLOR OPTIONS

- 10 color options

WARRANTY

- PolyTurf Plus Pad & Pour is backed by a 30-year warranty

BENEFITS

- ▶ Engages two types of elasticity
- ▶ Very high levels of shock absorption and more uniformity
- ▶ One of the best solutions for reducing fatigue and increasing comfort
- ▶ Healthier Choice® foam underlayment is GREENGUARD Gold certified
- ▶ The 18 mm plywood planks are made exclusively from birch, an extremely stable species of wood that provides a uniform structure for resilient sports surfaces
- ▶ ASTM F2772 Class 4
- ▶ Floorscore Certified
- ▶ Competition-level volleyball & basketball



INTRODUCING THE LUMAFLEX SYSTEMS

LUMAFLEX ELITE

Lumaflex Elite is a Class 5, high performing gym flooring solution that provides an unparalleled combination of deformation, performance, safety and comfort. By adding an area-elastic birch plywood sub-system to a point-elastic surface, Lumaflex Elite brings your game to another level.

Resilient Point-Elastic Surface:

Lumaflex Elite can be used with a variety of Tarkett Sports' gym flooring options, including Omnisports, EcoPure and PolyTurf Plus Pad and Pour.

Lumaflex Elite Cushion Strips:

Lumaflex Elite uses Tarkett Sports' Elite Continuous Cushion 1/2" x 3" strips of foam, which act as a sleeper system. The system will achieve Class 5 shock absorption with any of the surfacing options.



Uniform Structural Support:

These 18 mm birch plywood planks provide stability and a uniform structure for resilient sports surfaces. They are made exclusively from birch, one of the most stable species of wood.

Reliable Bonding and Assembly:

Each birch plywood plank incorporates an off-set, interlocking tongue-and-groove edge that is glued using Tarkett's specifically designed application nozzle. This allows fast and reliable installation.

TARKETT SPORTS LUMAFLEX PRODUCTS

ECOPURE LUMAFLEX



APPLICATIONS

- School Gymnasiums
- High Schools
- Colleges and Universities
- Wood Floor renovation
- Fitness/Aerobic

SURFACE LAYER OPTIONS

- EcoPure 3.2 mm

COLOR OPTIONS

- 8 color options

WARRANTY

- EcoPure is backed by an 8-year warranty

OMNISPORTS LUMAFLEX



APPLICATIONS

- High-level Sports/Fitness Facilities
- Competitive Courts
- Dedicated Basketball or Volleyball Courts
- Wood floor renovation
- Aerobics Areas

SURFACE LAYER OPTIONS

- Omnisports Compact, 3.5 mm, 5.5 mm, 7.1 mm and 9.4 mm

COLOR OPTIONS

- Color options depend on Omnisports surface layer chosen

WARRANTY

- Omnisports is backed by a 15-year warranty

POLYTURF PLUS PAD & POUR LUMAFLEX

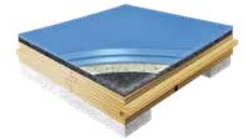

APPLICATIONS

- School Gymnasiums
- High Schools
- Colleges and Universities
- Wood Floor renovation
- Fitness/Aerobic

SURFACE LAYER OPTIONS

- PolyTurf Plus 4+2, PolyTurf Plus 7+2, PolyTurf Plus 9+2

COLOR OPTIONS

- 10 color options

WARRANTY

- PolyTurf Plus Pad & Pour is backed by a 30-year warranty

BENEFITS

- ▶ Engages two types of elasticity
- ▶ Elite levels of shock absorption and more uniformity
- ▶ One of the best solutions for reducing fatigue and increasing comfort
- ▶ Lumaflex Elite can be modified to meet height requirements, especially when replacing a wood floor within an existing recessed slab
- ▶ The 18 mm plywood planks are made exclusively from birch, an extremely stable species of wood that provides a uniform structure for resilient sports surfaces
- ▶ ASTM F2772 Class 5
- ▶ Floorscore Certified
- ▶ Competition-level volleyball & basketball



INTRODUCING THE LUMAFLEX SYSTEMS

LUMAFLEX FIT

Lumaflex Fit is a Class 5 competition-level fitness and aerobics flooring solution that provides an unparalleled combination of deformation, performance, safety and comfort. By adding an area-elastic birch plywood sub-system to a point-elastic surface, Lumaflex Fit brings fitness to another level.

Resilient Point-Elastic Surface:

Lumaflex Fit can be used with Tarkett Sports' Omnisports.

Lumaflex Pro 1 Pads:

Lumaflex Fit uses Tarkett Sports' Pro 1 Pads that are round, 1" thick cushion pads. The force Reduction reaches >70%.

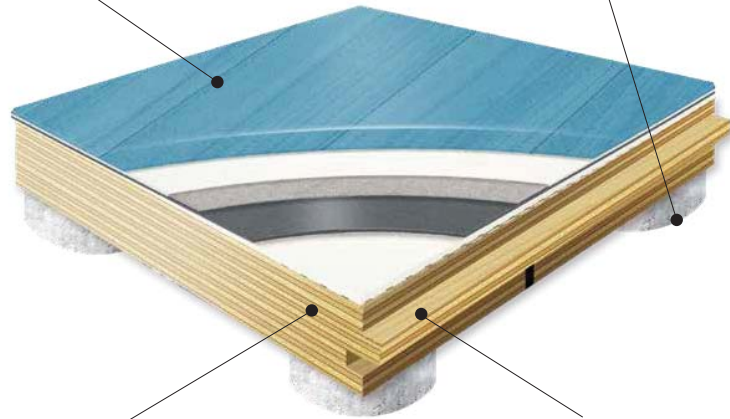

Uniform Structural Support:

These 18 mm birch plywood planks provide stability and a uniform structure for resilient sports surfaces. They are made exclusively from birch, one of the most stable species of wood.

Reliable Bonding and Assembly:

Each birch plywood plank incorporates an off-set, interlocking tongue-and-groove edge that is glued using Tarkett's specifically designed application nozzle. This allows fast and reliable installation.

TARKETT SPORTS LUMAFLEX PRODUCTS

OMNISPORTS LUMAFLEX

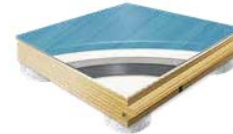

APPLICATIONS

- Fitness Areas
- Wood floor renovation
- Aerobics Areas

SURFACE LAYER OPTIONS

- Omnisports Compact, 3.5 mm, 5.5 mm, 7.1 mm and 9.4 mm

COLOR OPTIONS

- Color options depend on Omnisports surface layer chosen

WARRANTY

- Omnisports is backed by a 15-year warranty



BENEFITS

- ▶ Engages two types of elasticity
- ▶ Very high levels of shock absorption and more uniformity
- ▶ One of the best solutions for reducing fatigue and increasing comfort
- ▶ Lumaflex Fit can be modified to meet height requirements, especially when replacing a wood floor within an existing recessed slab.
- ▶ The 18 mm plywood planks are made exclusively from birch, an extremely stable species of wood that provides a uniform structure for resilient sports surfaces
- ▶ ASTM F2772 Class 5
- ▶ Floorscore Certified
- ▶ Competition-level fitness, dance & aerobics



BOSTON UNIVERSITY

TARKETT SPORTS COMPLETES LUMAFLEX INSTALLATION AT BU

LUMAFLEX: A MULTIPURPOSE FLOOR WITH TOP END SPORTS PERFORMANCE

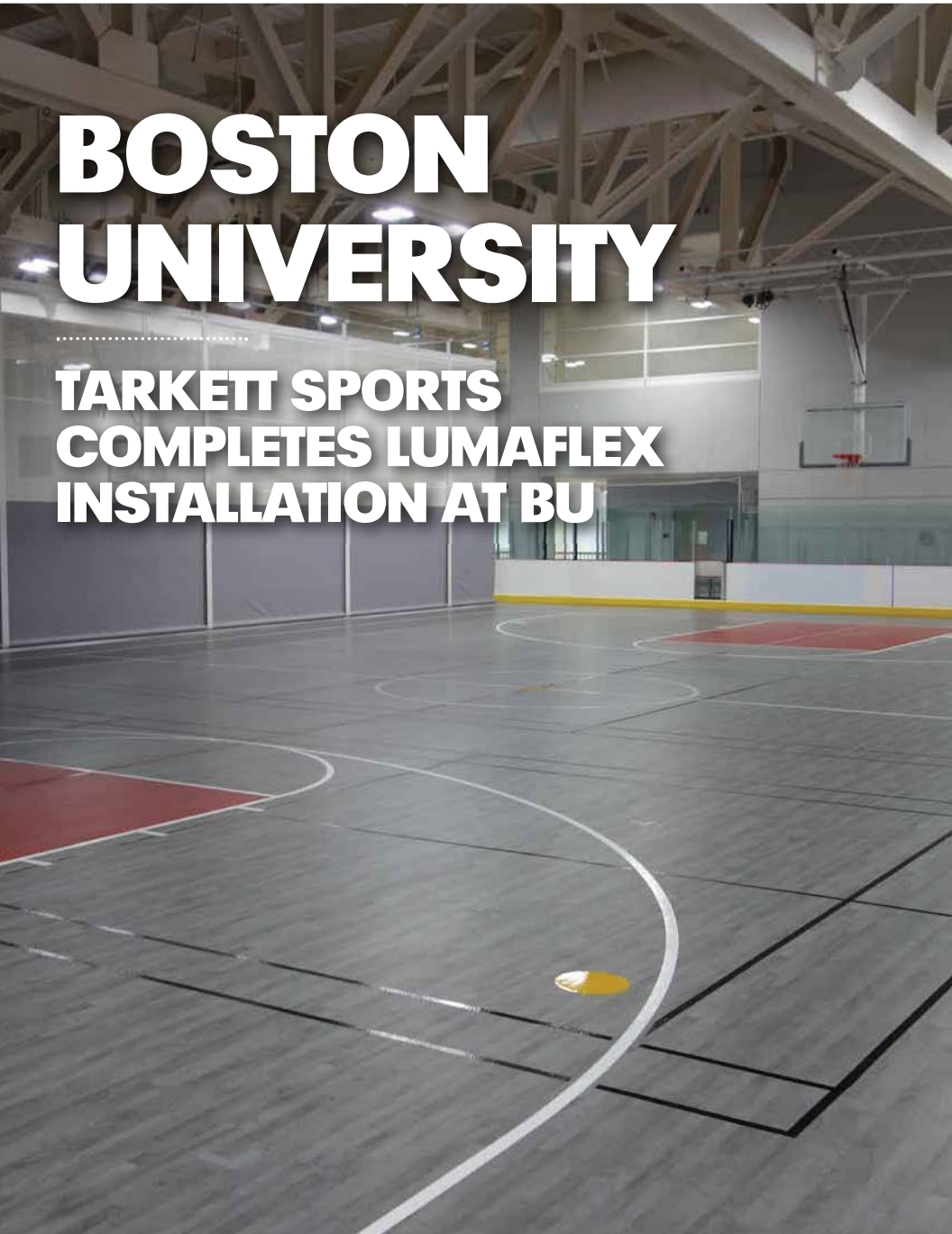

Boston University was in need of a new floor for their Fitness and Recreation Center that could accommodate all aspects of their facility's daily operation, while not sacrificing performance. Boston University selected the Tarkett Sports Lumaflex system. A Lumaflex system works hard to meet and exceed the customer's needs.

Lumaflex is more than a high performance combination athletic system; it is a multipurpose floor with many capabilities and benefits. Boston University chose Lumaflex with Omnisports Compact, grey and red maple design, for a truly unique and versatile floor.

The use of Lumaflex with Omnisports extends beyond just sports. It can host non-sport activities with tables, chairs, and staging. This makes Lumaflex the perfect system for non-sports applications, such as graduation ceremonies, dances, banquets, trade shows, and much more. These are just a few of the benefits for Boston University.

With the durability to hold a multitude of events in the same space, the advantages of Lumaflex will help create a long-term investment for the owner with the lowest life-cycle cost on the market.



HARDEST PLYWOOD

ON THE MARKET

LUMAFLEX IS A TECHNICAL SUB-CONSTRUCTION DESIGNED TO MEET DIFFERENT FLEXIBILITY AND TENSION REQUIREMENTS

- ▶ Lumaflex is a technical sub-construction designed to meet different flexibility and tension requirements.
- ▶ The unique off-set, 18 mm, double tongue-and-groove plywood planks provide unparalleled stability and a uniform structure.
- ▶ This revolutionary system in conjunction with a Tarkett Sports resilient point-elastic surface, enables the floor to withstand the heaviest point loads typically found in sports facilities.
- ▶ Cross-hatched grooves provide more controlled board flexibility.
- ▶ High density foam on the whole surface for homogeneous/continuous absorption and better acoustic insulation.

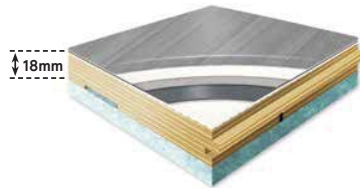

LUMAFLEX SYSTEM

UPGRADING TO LUMAFLEX

IF YOU ARE REPLACING A HARDWOOD SPORTS FLOOR, YOUR CHALLENGE IS A RECESSED CONCRETE SLAB THAT IS LOWER THAN THE REST OF YOUR FACILITY. BELOW ARE THREE REPLACEMENT POSSIBILITIES

OPTION 1

REPLACE WITH HARDWOODS

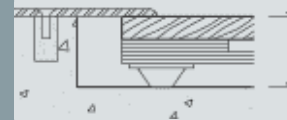

This option offers the high shock absorption of area-elastic flooring, but it perpetuates costly upkeep, and may provide less versatility.

OPTION 2

FILL THE GAP

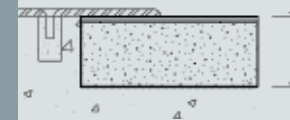

This option adjusts the profile, but it adds no additional sports performance properties like shock absorption and can be very costly to install.

OPTION 3

UPGRADE TO A LUMAFLEX SYSTEM

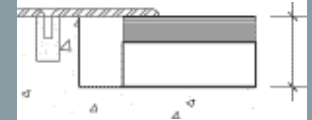

The Lumaflex system corrects profile difference while adding class 4 or 5 shock absorption, plus the low maintenance and versatility of Tarkett's resilient sports flooring.

WITH A LUMAFLEX SYSTEM, THIS COMMON RENOVATION PROBLEM ISN'T A PROBLEM AT ALL. IT'S POTENTIAL.

ELEVATE YOUR GAME

WITH LUMAFLEX



AVALON SCHOOL
Avalon, CA
Installed in 2017



SOUTH KINGSTOWN HIGH SCHOOL
South Kingstown, RI
Installed in 2017

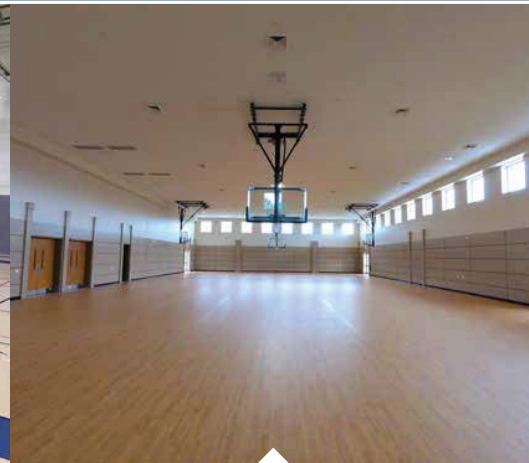

BAIS TOVA GIRLS ELEMENTARY SCHOOL
Lakewood, NJ
Installed in 2018



JOHN F. HUGHES ELEMENTARY SCHOOL
Utica, NY
Installed in 2018



WHITBY HIGH SCHOOL
Greenwich, CT
Installed in 2015



BOSTON UNIVERSITY
Boston, MA
Installed in 2019



PALAIS DES SPORTS
Loudeac, France
Installed in 2014



YORKSHIRE SUBURBAN HIGH SCHOOL
York, PA
Installed in 2016



THE TARKETT SPORTS FAMILY - LEADERS IN SPORTS SURFACING



888-364-6541 | tarkettsportsindoor.com



OMNISPORTS

Play to win



 **Tarkett**SPORTS
INDOOR

INDEX

WHY TARKETT SPORTS IS THE RIGHT CHOICE	4
WHY OMNISPORTS	6
DESIGNED FOR EASY MAINTENANCE	8
DESIGNED FOR DURABILITY	10
THE OPTIMAL SURFACE FOR ATHLETES	12
DESIGNED TO BE SAFE	14
TRUSTED AT ALL LEVELS	16
STANDARDS & CLASSES	18
OMNISPORTS RANGE	20
THE OMNISPORTS COLLECTION	
CLASS 1 SYSTEMS	22
CLASS 2 SYSTEMS	24
CLASS 3 SYSTEMS	26
CLASS 4 SYSTEMS	28
UNLIMITED DESIGN POSSIBILITIES	30
INSTALLATION METHODS	32
SOLUTION GUIDE	34
TECHNICAL DATA	35

OMNISPORTS

Everything we do, and the way we do it, is aimed to make the process easier for you. We focus on ensuring your experience is memorable and hassle-free.

We understood long ago that a successful sports surface relies on a quality product that's installed by a quality team. We've built our Omnisports Series by combining the best systems with the best people and the best partners. You can trust the renowned quality of Omnisports and the reputed experience of our team.

**We're ready to partner on your next project.
Let's get started!**

TARKETT SPORTS IS A WORLD LEADER IN ATHLETIC SURFACING, OFFERING A COMPREHENSIVE PORTFOLIO OF INDOOR AND OUTDOOR SPORTS SURFACES. OUR MISSION: TO OFFER SUSTAINABLE SPORTS SURFACES THAT MAKE THE DIFFERENCE FOR ATHLETES.



TARKETT SPORTS BRAND

Tarkett Sports is a world leader in athletic surfacing, offering a comprehensive portfolio of sports flooring solutions through its brands: FieldTurf, Beynon Sports, Renner Sports, EasyTurf, Desso, GrassMaster, PlayMaster and Tarkett Sports Indoor.



DESIGN & CONSTRUCTION EXPERTS

Tarkett Sports and our partners are some of the most experienced and knowledgeable teams in the industry. When it comes to the design and construction of your sports surface, we are the experts.



FINANCIALLY STABLE

The Tarkett Group is a worldwide leader of innovative flooring and sports surface solutions. Tarkett Sports Indoor is backed by unprecedented financial support and stability. You can rest easy.



LEADING DURABILITY

Manufactured and installed with the highest attention to detail, Tarkett Sports Indoor's systems showcase proven durability.



EXPERIENCE

With over 5,000 installations in North America in the last 10 years, Tarkett Sports Indoor has the knowledge and expertise to make your sports facility a success.



TRUSTED

For indoor facilities, Tarkett Sports Indoor offers the most trusted sports flooring for various style facilities in North America.



ENDLESS PURSUIT OF INNOVATION

From the Dropzone rubber, PolyTurf Plus Pad & Pour system, Omnisports vinyl sports flooring, ClutchCourt wood, and LinoSport linoleum, our innovation and versatility extend beyond just sports. We're there to support your team.



SERVICE

We are as committed to your program as you are, and we're with you for the long term. When you buy from Tarkett Sports, you're buying from a company that knows how to take care of you.

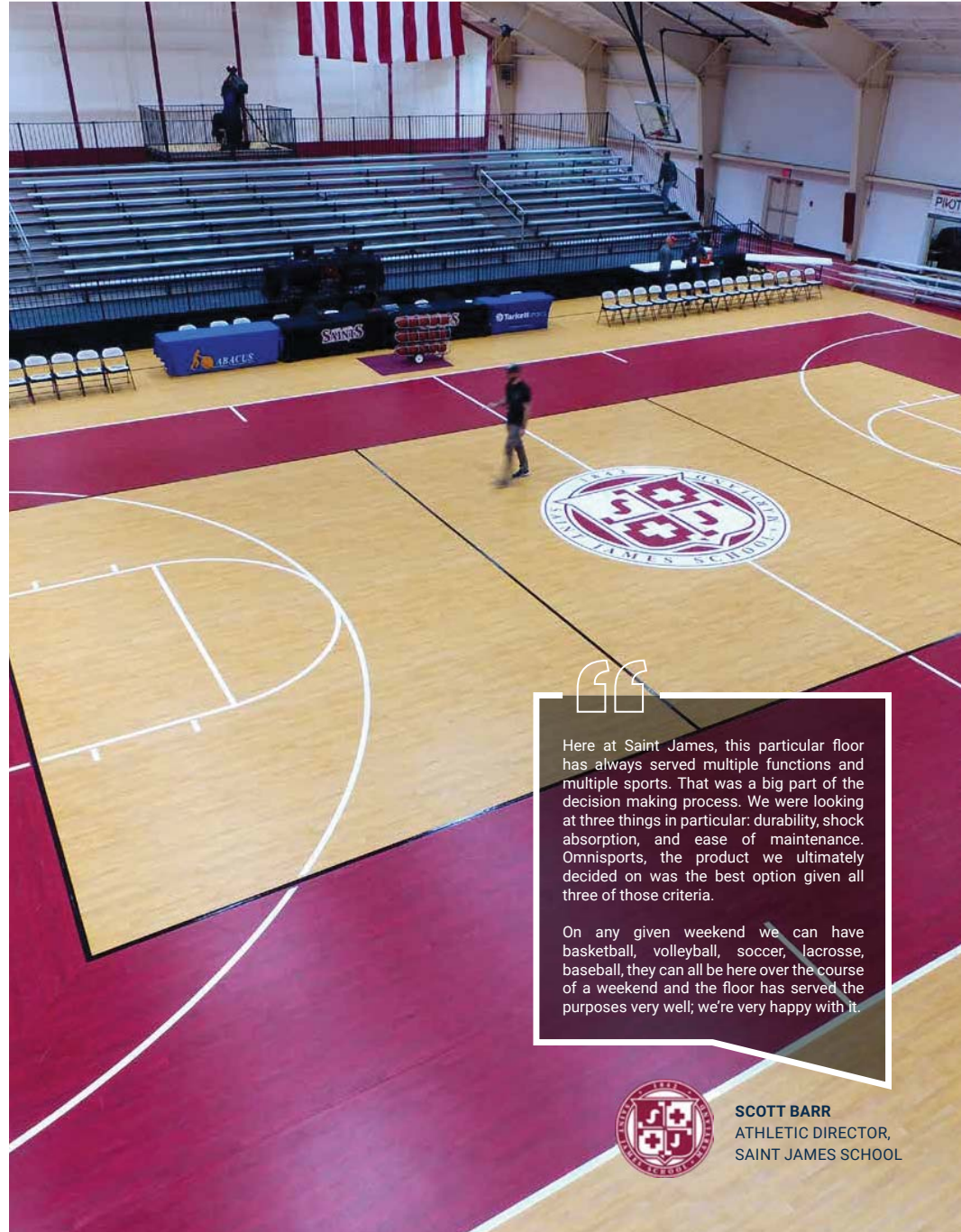

Here at Saint James, this particular floor has always served multiple functions and multiple sports. That was a big part of the decision making process. We were looking at three things in particular: durability, shock absorption, and ease of maintenance. Omnisports, the product we ultimately decided on was the best option given all three of those criteria. On any given weekend we can have basketball, volleyball, soccer, lacrosse, baseball, they can all be here over the course of a weekend and the floor has served the purposes very well; we're very happy with it.



SCOTT BARR ATHLETIC DIRECTOR, SAINT JAMES SCHOOL

ENGINEERED TO DOMINATE

DESIGNED TO IMPRESS

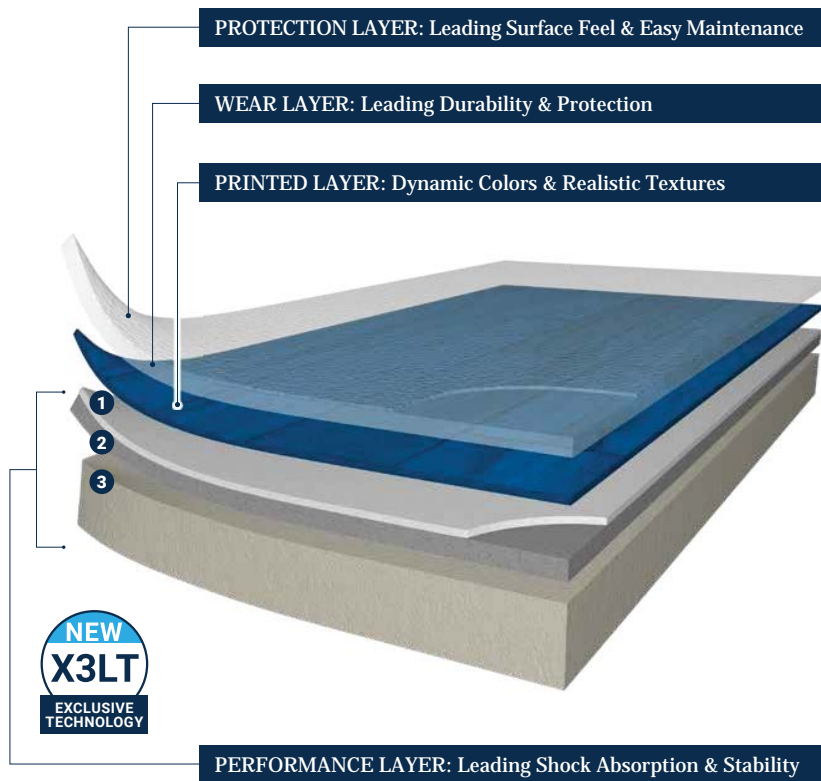

PROVEN HISTORY & REFERENCES



BUILT TO BE THE MUSCLE ON YOUR TEAM



MADE TO STAND OUT VARIETY OF DESIGN OPTIONS

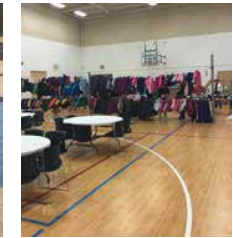

MULTIFUNCTIONAL SPORTS, RECREATION, ACTIVITIES & MORE

YOU CAN FEEL THE DIFFERENCE

OMNISPORTS X³LT - XTREME 3 LAYER TECHNOLOGY

<p>1</p> <p>FIBERGLASS MESH Less is more! Extremely tough single fiberglass mesh reinforcement</p> <p>2X</p> <p>BETTER INDENTATION RECOVERY THAN SIMILAR PRODUCTS</p>	+	<p>2</p> <p>CALENDARED SHEET High performance & durability, made from recycled material</p> <p>Up to 60%</p> <p>RECYCLED CONTENT</p>	+	<p>3</p> <p>XCS CUSHION High expansion rate and recovery, less fillers for maximized performances</p> <p>+12%</p> <p>IMPROVED SHOCK ABSORPTION</p>
---	---	--	---	--

UNRIVALED SPORTS EXPERIENCE

Our XCS aerated, high cell density cushion, offers improved comfort while providing leading indentation recovery. Delivering excellent fatigue reduction, the Performance Layer allows athletes to play longer and recover faster.

A WINNING COMBINATION

The magic happens by combining our best features. Together, the XCS high-quality expanded cellular cushion combined with our durable resilient calendar layer and extremely tough fiberglass mesh provides improved sports performance and a higher resistance to rolling and static loads than competitor systems.

WASH, RINSE & PLAY

Maintenance is that easy with Omnisports. Our systems are finished with our factory applied polyurethane surface treatment, TopClean XP. The application delivers leading resistance to scratches, scuffs, stains and abrasion. As the TopClean XP surface treatment does not promote organism microbial growth, the system reduces the possibility of bacteria and micro-organisms build up on the surface.

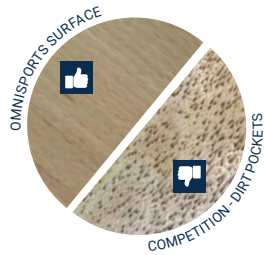

FREE OF DIRT POCKETS

The Tarkett Difference – Omnisports’ unique single-surface embossing repels dirt, unlike some systems that trap dirt in surface pockets.



TABLES & CHAIRS, BRING IT ON

Omnisports systems offer exceptional resistance to indentation marks and rolling loads. The surface can safely be used for events and recreational activities that require temporary equipment and furniture to be placed on the surface.



HIGHLY RESISTANT TO STAINS

Omnisports systems are engineered to deliver leading resistance to staining and footwear marks. Spills are easily cleaned and the surface requires less maintenance.



LESS TIME CLEANING

Omnisports systems are easy to maintain as they require mechanical cleaning no more than once a week. You could save up to 25% on your maintenance budget.



OVER
30%*
THICKER WEAR LAYER
 VS LEADING COMPETITOR SYSTEMS

* Based on ISO 24340 standard

Our Omnisports vinyl wear layer delivers long lasting protection for unmatched value.

30% thicker than the leading competitor systems and made of pure polyvinyl chloride (PVC), Omnisports' wear layer provides excellent floor protection and is backed by a leading 25-year warranty.

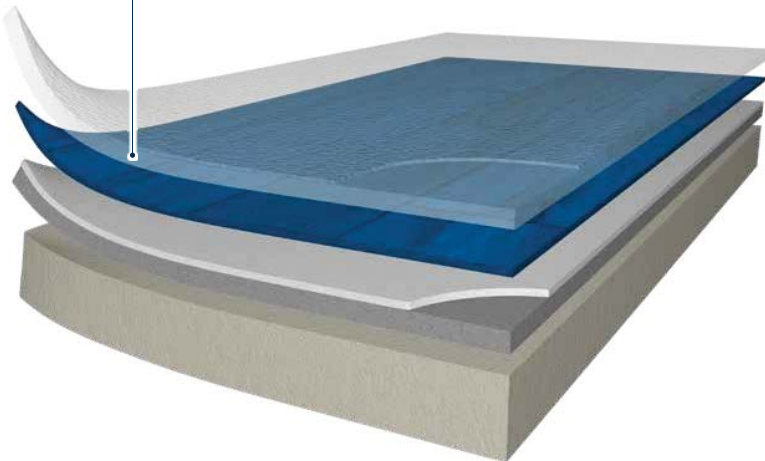

MEASURE YOUR WEAR LAYER CORRECTLY

The wear layer is the portion of a resilient floor covering that contains or protects the pattern effect. With a thin wear layer, your surface could quickly show signs of wear and damage. Tarkett Sports relies on ASTM F1303, a leading industry standard, to define its wear layer thickness. Some manufacturers include additional layers as a part of their wear layer calculation. When comparing systems, be sure to compare using identical methods.

HOW TO MEASURE WEAR LAYER THICKNESS AND WHAT DEPTH IS ENOUGH?

- Rely on independent testing standards – We recommend ASTM F1303 testing
- Select the proper type and grade for your facility
- Be cautious of manufacturers advertising thicknesses based on "internal" testing
- Ask for and read the full details of the warranty of your wear layer
- An inadequate wear layer could lead to premature damage to your surface

WEAR LAYER DEFINITION ASTM F1303 VS OTHER METHODS

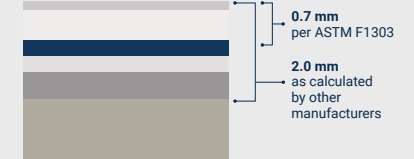

MAKE SURE YOU'RE COMPARING THE IDENTICAL METHODS

	OMNISPORTS ACTIVE+	COMPETITOR SYSTEM	DIFFERENCE
Wear layer per ASTM F1303	0.7 mm	0.5 mm	+40%
Wear layer as calculated by other manufacturers	2.0 mm	2.1 mm	-5%

ASK IF YOUR SYSTEM IS DESIGNED FOR COMMERCIAL USE

Rely on the Standard for Sheet Vinyl Flooring - ASTM F1303 testing

TYPE	GRADE	WEAR LAYER THICKNESS (MM)	INTENDED USE	RECOMMENDED FOR SPORT APPLICATIONS
Type 1 (Min. 90% PVC binder content)	Grade 1: >0.51mm	0.51	Residential / Commercial / Light Commercial	✓
Type 1 (Min. 90% PVC binder content)	Grade 2: 0.51mm><0.36mm	0.36	Residential / Light Commercial	✗
Type 1 (Min. 90% PVC binder content)	Grade 3 0.36mm><0.25mm	0.25	Residential	✗

COMFORT & PERFORMANCE



WORLD-CLASS FEELING UNDERFOOT Leading Shock Absorption

Our XCS aerated, high cell density cushion, delivers leading shock absorption, comfort and indentation recovery. The engineered cushioning technology also assists with excellent fatigue reduction allowing for longer and safer play at both recreational and competitive levels.

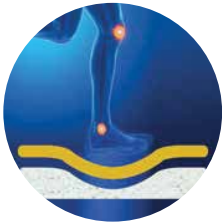

LESS IMPACT ON THE BODY Leading Energy Return

XCS high-quality expanded cellular cushion combined with our durable resilient calendared layer and extremely tough reinforcing fiberglass mesh provides superior fatigue reduction, better sports performance, and higher resistance to rolling and static loads compared to competitor systems.



BETTER GRIP CONTROL Consistent surface friction

Omnisports' homogeneous top embossing and surface treatment provide the proper balance of friction and grip control. It reduces friction burn risks and provides safer protection with anti-slip grip on all patterns and colors.

TARKETT SPORTS DIFFERENCE

No change in grip and feeling underfoot when moving from solid color to pattern

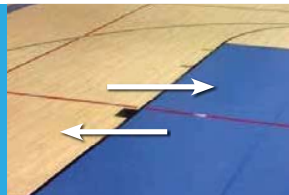

FOR THE ATHLETE & FOR THE PLANET

Because sustainable sport is integral to the well-being of our communities, preserving our ecosystems is a part of what drives all of our product innovation. After all, if there's no planet, there's no play. Our commitment to sustainability is focused and unwavering.

- OMNISPORTS PRODUCTS ARE 100% RECYCLABLE
- CONTRIBUTES TO FACILITY LEED CERTIFICATION
- TARKETT IS RECOGNIZED AS A WORLD LEADER IN SUSTAINABILITY



CUTS OUT THE NOISE TO FOCUS ON THE GAME

The Omnisports series is designed with a cushion vinyl backing that reduces noise levels and provides optimal acoustic comfort. 

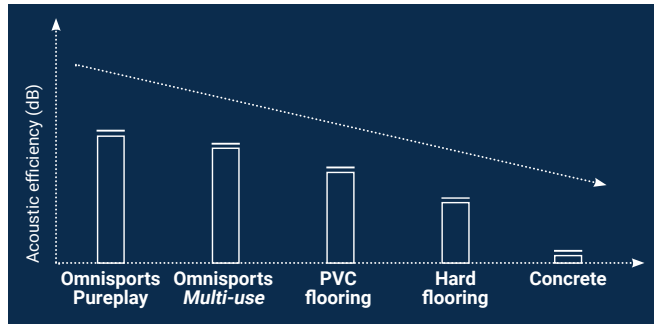

NOTHING IS MORE IMPORTANT THAN THE SAFETY OF YOUR ATHLETES

Indoor air quality is essential for athletes' health and especially children who are exposed to higher risk of indoor pollution due to immature lungs. The materials in the Omnisports range were carefully selected to deliver a surface that provides optimal indoor air quality.



PHthalate-FREE MANUFACTURING

As part of Tarkett's initiative for sustainability and eco-innovation, Omnisports is one of the only phthalate-free resilient sports floors available in North America.

- Improves the indoor environment and air quality
- Same components used in food containers and children's toys



ASTHMA & ALLERGY FRIENDLY

Omnisports was the first sports surface to be certified asthma & allergy friendly, providing a healthier sports flooring solution. When combined with Multi-Poxy Adhesive from Tarkett Sports, Omnisports Active+ and Pureplay with popular GreenLay™ installation exceed all of the asthma & allergy friendly certification standards

- Low voc emissions
- Low allergen retention



LOW VOCs AND BETTER INDOOR AIR QUALITY

A healthy indoor environment begins with low levels of volatile organic compounds (VOCs).

- VOC emissions less than 10 micrograms per cubic meter*
A lower VOC emission rate than most other resilient sports floors
*VOCs after 28 days (ISO 16000)
- Complies with California Section 01350, the most stringent air quality regulation in the U.S.

TRUSTED AT ALL LEVELS

OVER 10,000 INSTALLATIONS WORLDWIDE



Blue Springs
Fieldhouse
Blue Springs, MO



City of
Valle Vista
Valle Vista, CA

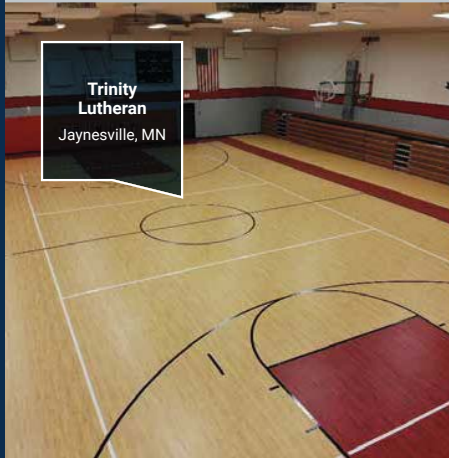

Trinity
Lutheran
Jaynesville, MN



Algiers
Charter
School
New Orleans, LA



San Angelo
Sports
Complex
Odessa, TX



Saint-James
School
St. James, MD



Plainfield
High School
Plainfield, IL



The Albany
Academy
Albany, NY



Gilliland
Middle
School
Tempe, AZ



Total Turf
Experience
Pitman, NJ

UNDERSTANDING SPORTS FLOORING

To help guide you to the right system for your facility, we rely on the independent flooring standard, ASTM F2772. This way, you can better evaluate and compare similar systems. Let's focus on the facts and cut out the noise.

HOW DOES THE SPORTS FLOORING STANDARD WORK?
It focuses on four critical areas:

1 FORCE REDUCTION (SHOCK ABSORPTION)

Force reduction (also called "shock absorption") evaluates a surface's ability to reduce impact force. The standard has set a minimum value of 10% force reduction and categorizes the remain range into five Classes, of which Class 5 has the highest force reduction.

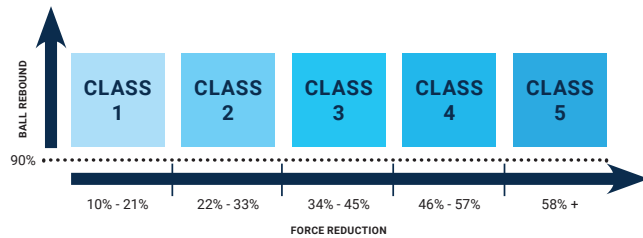

2 BALL REBOUND

Ball rebound (also called ball bounce) is a mechanical property that determines a surface's suitability for basketball. It is tested according to ASTM F2117 and accounts for two parameters: performance level (average performance of test points must reach a minimum of 90%) and uniformity level (test point deviation cannot exceed 3% of the average of all tests). Ball rebound is based on the responsiveness of a ball and its interaction with the surface. It is calculated by comparing the ball's rebound height on the sports surface to the rebound height of the same ball on concrete.

This area is concluded as a pass or fail, no classes.



3 VERTICAL DEFORMATION

Vertical deformation values indicate the ability of the surface to deform under load. High deformation can affect the safety of the athlete, causing instability of the foot, while low deformation may cause injuries as a result of immediate impact force.

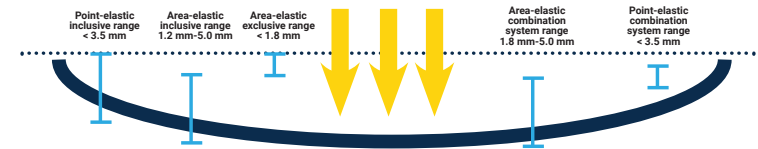

4 SURFACE FINISH EFFECT (FRICTION)

Surface finish effect describes a surface's response to a sliding foot, typically under dry conditions. It is tested according to ASTM E303 and accounts for two parameters: performance level (testing must achieve a value between 80-110) and uniformity level (individual tests cannot vary more than 4 points from the average value)

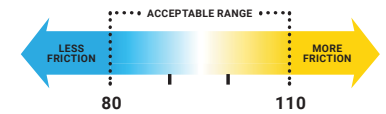

OMNISPORTS RANGE

CLASS
1

SPEED



HPL 7

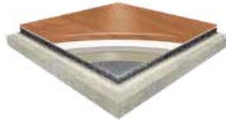

CLASS
2

MULTI-USE



HPL 9



CLASS
3

ACTIVE+



PUREPLAY



CLASS
4

EXTREME

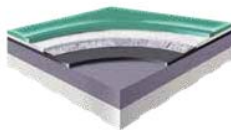

CLASS
5

LOOKING FOR A **CLASS 5** OPTION?
ASK US ABOUT OUR **LUMAFLEX** SYSTEMS

Carolina
Courts
Indian Trail, NC

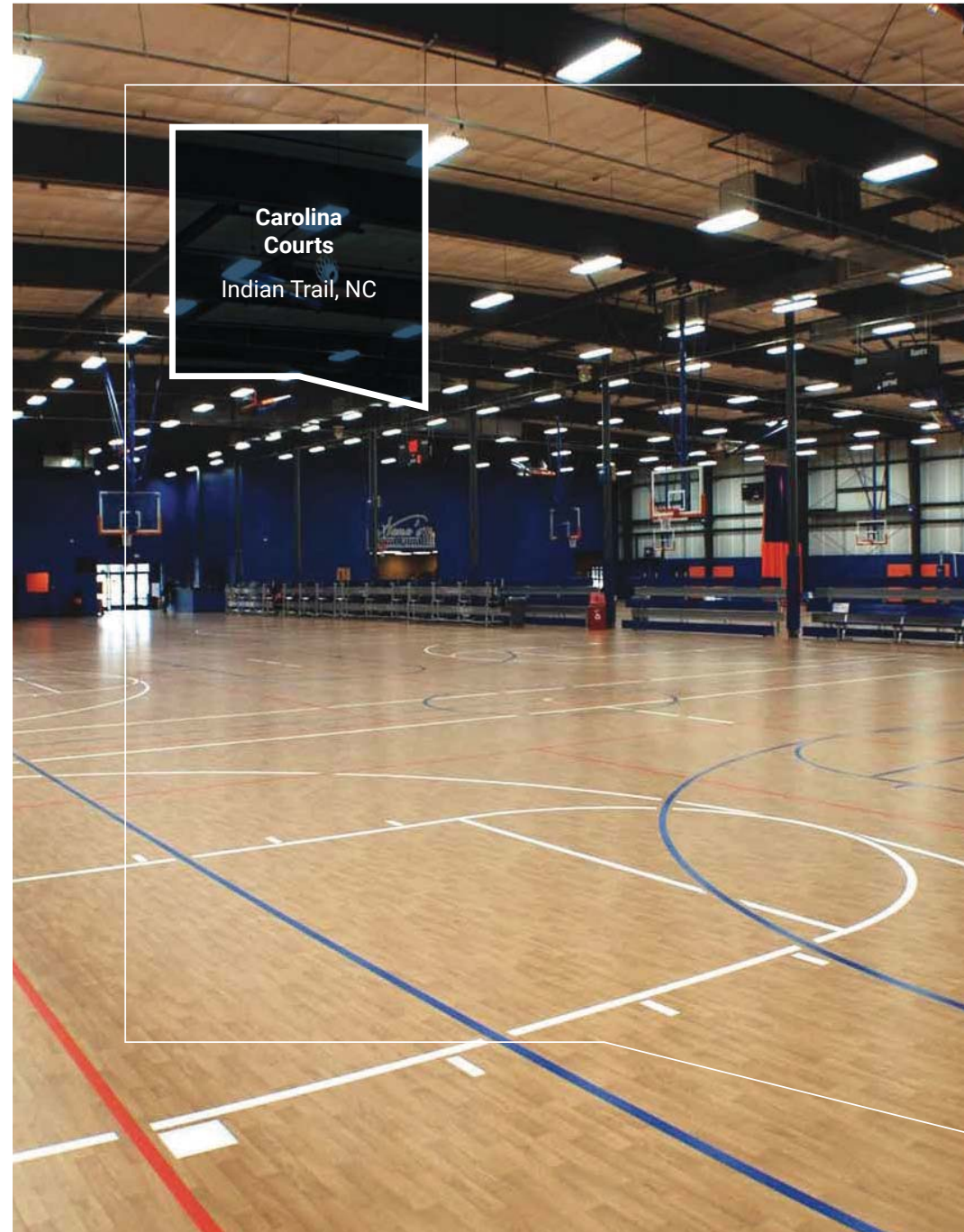

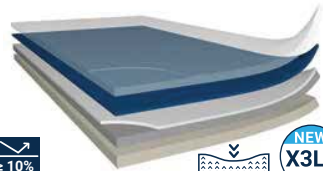

NEW! **SPEED**

Ideal for walking and acoustic comfort in fitness, leisure and wellness areas

KEY FEATURES

- Ideal noise reduction
- High resistance to indentation marks: **0.18mm**
- High resistance to rolling loads
- Easy Maintenance



APPLICATIONS

Table tennis, badminton



FORMAT



Roll
75.5' x 6.5'

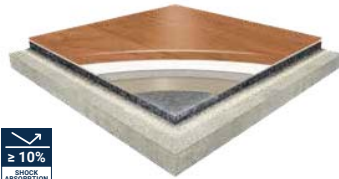

HPL 7

Ideal for heavy bleachers and equipment as well as sports

KEY FEATURES

- Class 1 shock absorption
- Tolerates static and rolling loads as well as any vulcanized rubber surface, up to **500 psi**
- Easy Maintenance
- Phthalate-Free Manufacturing
- Consistent playability and a uniform texture of all material selected, regardless of color



APPLICATIONS

Multi-use, pickleball, fitness-cardio, wellness centers, roller sports, yoga, traffic areas



FORMAT



Roll
85.3' x 6.5'

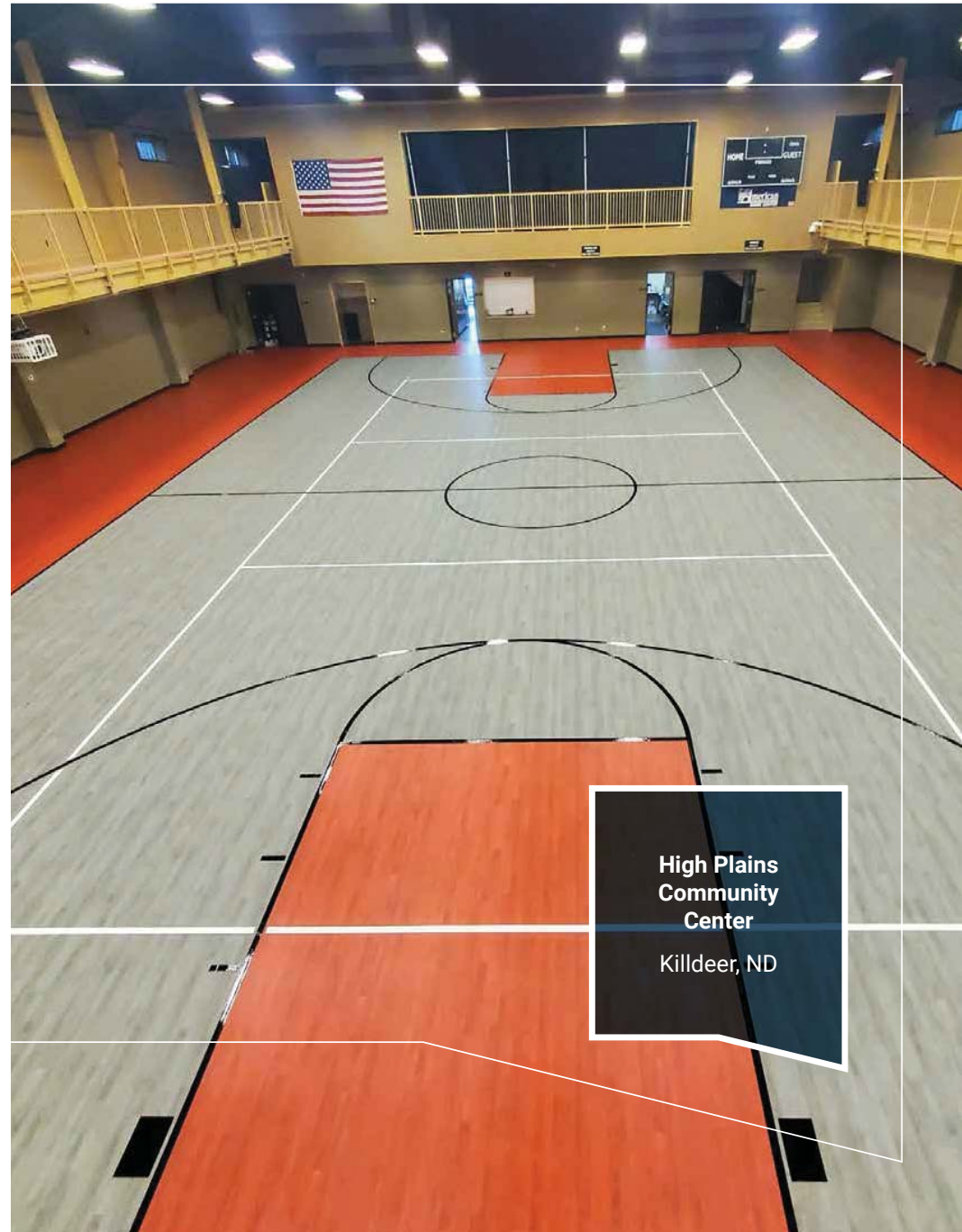

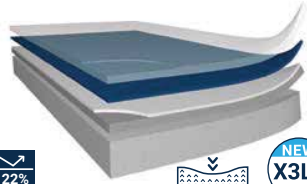

NEW! MULTI-USE

Ideal flooring for multi-sports practice and non-sporting events

KEY FEATURES

- Class 2 shock absorption: **≥25%**
- Exceptional resistance to static loads (chairs, tables, bleachers,...): **≤0.10mm***
- Superior resistance to heavy rolling loads (trolleys...)
- Resistance to stains and scratches: **0.70mm PU reinforced wear layer**
- Available with **GreenLay™** exclusive installation method: **98% adhesive-free****



APPLICATIONS

Multi-sports: basketball, volleyball, handball, badminton, futsal, table tennis, pickleball... and non-sporting events: exams, elections, balls, public meetings, association meetings...



FORMAT



Roll 85.3' x 6.5'

*Chair with 176 lb. person during 5h.
**See page 33

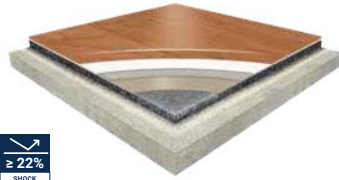

HPL 9

Ideal for heavy bleachers and equipment as well as sports.

KEY FEATURES

- Class 2 shock absorption
- Tolerates static and rolling loads as well as any vulcanized rubber surface, up to **500 psi**
- Easy Maintenance
- Phthalate-Free Manufacturing
- Consistent playability and a uniform texture of all material selected, regardless of color.



APPLICATIONS

Multi-use, pickleball, fitness-cardio, wellness centers, roller sports, yoga, traffic areas



FORMAT



Roll 85.3' x 6.5'



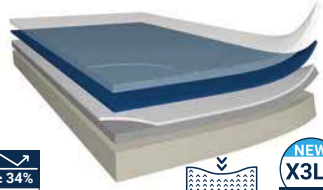

NEW! ACTIVE +

Ideal balance of performance & comfort for multi-sports

KEY FEATURES

- Class 3 shock absorption: **≥35%**
- High noise reduction
- Excellent underfoot comfort for enhanced game experience and protection for athletes
- Easy Maintenance



APPLICATIONS

Multi-sports: basketball, volleyball, handball, badminton, futsal... and non-sporting events: exams, elections, balls, public meetings, association meetings...



FORMAT



* See page 33

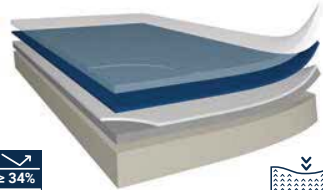

PUREPLAY

Extreme protection, comfort and sports performances

KEY FEATURES

- Class 3 shock absorption: optimized cushion-vinyl construction, our thickest foam for excellent performance
- Excellent underfoot comfort for enhanced game experience and protection for athletes
- Resistance to stains and scratches: **0.80mm PU reinforced wear layer**
- Available with **GreenLay™** exclusive installation method: **98% adhesive-free***
- Easy Maintenance



APPLICATIONS

Multi-sports: basketball, volleyball, handball, futsal, table tennis, pickleball, yoga...



FORMAT



Perkins
Elementary
School
Perkins, OK

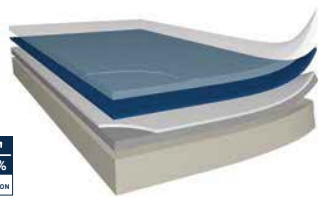

OMNISPORTS EXTREME

The ultimate competitive basketball, volleyball, fitness and aerobics gym flooring

KEY FEATURES

- Class 4 shock level absorption
- Maximum noise reduction
- Easy Maintenance
- Phthalate Free Manufacturing
- Consistent playability and a uniform texture of all material selected, regardless of color.
- Superior Dimensional Stability



APPLICATIONS

Multi-sports: basketball, volleyball, handball, futsal, table tennis, badminton, pickleball, fitness-aerobics, yoga...



FORMAT



Roll
49.2' x 6.5'



Cegep
Gerald-Godin
Quebec, Canada

UNLIMITED DESIGN POSSIBILITIES

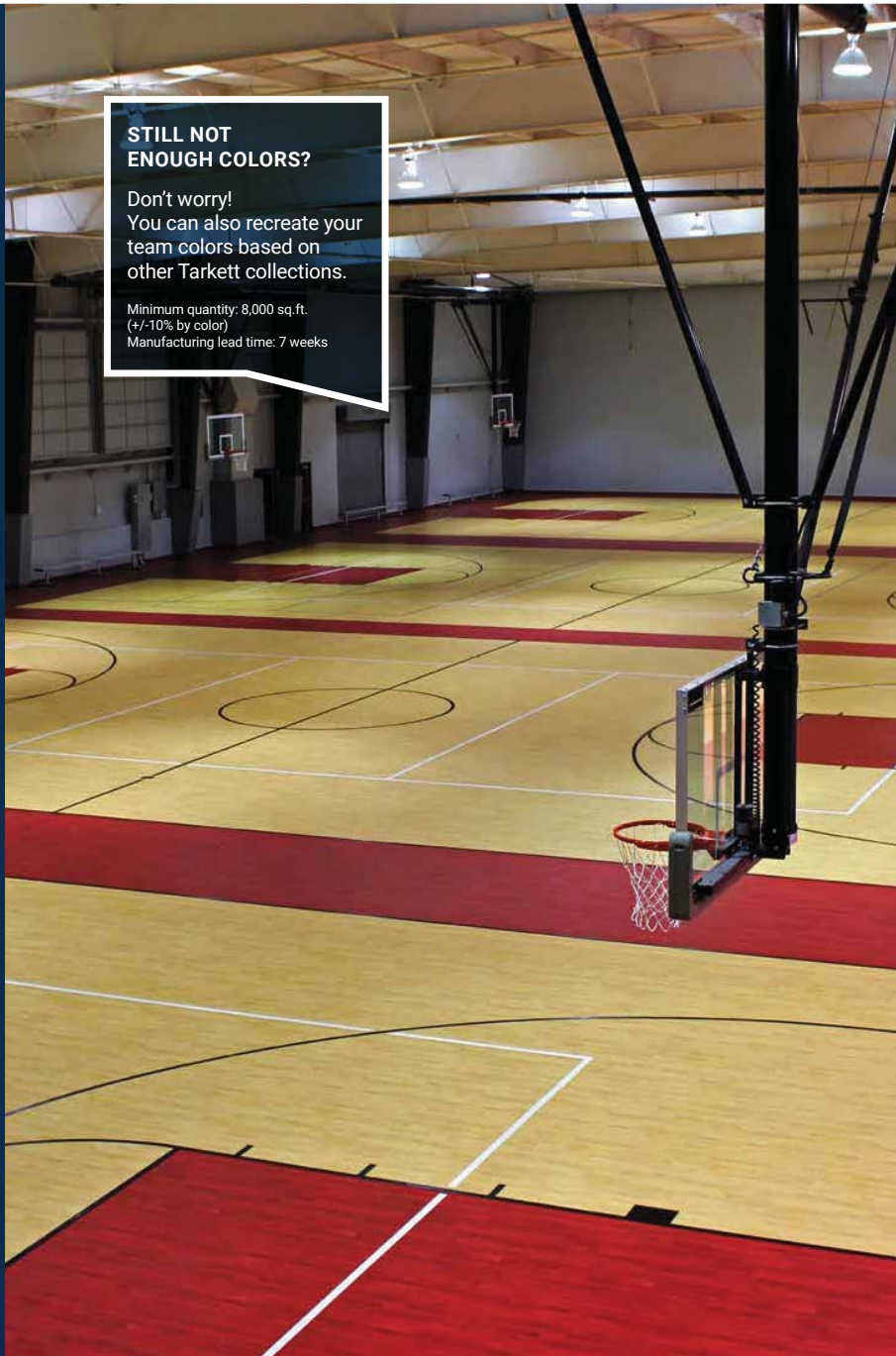

STILL NOT ENOUGH COLORS?

Don't worry!
You can also recreate your team colors based on other Tarkett collections.

Minimum quantity: 8,000 sq. ft.
(+/-10% by color)
Manufacturing lead time: 7 weeks

OMNISPORTS SPEED

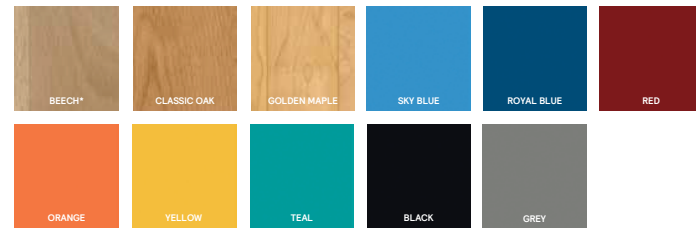

OMNISPORTS MULTI-USE / ACTIVE+ / PUREPLAY

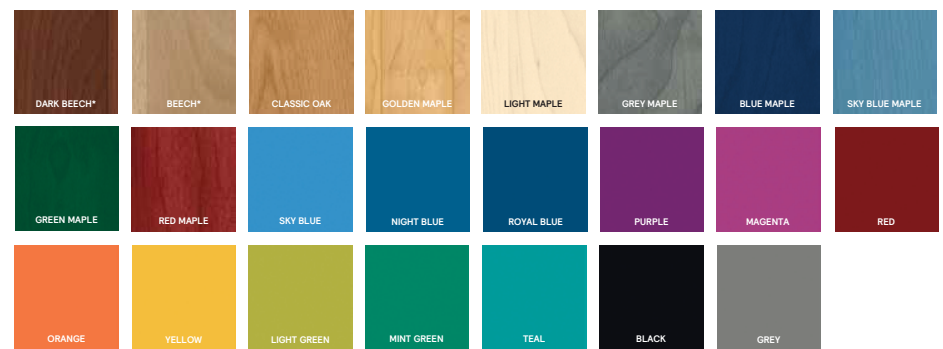

OMNISPORTS EXTREME



OMNISPORTS HPL

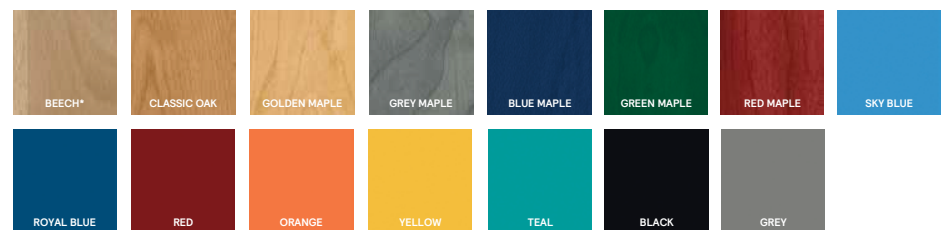

OMNISPORTS IS A VERSATILE SPORTS SURFACE THAT GOES BEYOND THE NUMBER OF SPORTS AND EVENTS IT CAN HOST



UNIQUE 2M ROLL WIDTH
30% less welding required, decreasing the areas at risk of soiling.

Omnisports needs to be installed according to the conditions on site to ensure maximum performance and durability. A variety of installation methods are available to accommodate each facility's particular circumstances.

SUBFLOOR INSTALLATION

INSTALLATION TYPE	MULTI-SET	HS SPORT SPRAY	GREENLAY	MULTI-POXY	TARKOLAY WITH MULTI-POXY
Concrete Substrate Maximum Tolerances	83% RH 4% MC	90% RH 4.5% MC	92% RH 5% MC	98% RH 6% MC	Moisture Testing Not Required*
Omnisports Speed	✓	✓	✗	✓	✓
Omnisports Multi-Use	✓	✓	✓	✓	✓
Omnisports Active+	✓	✓	✓	✓	✓
Omnisports Pureplay	✓	✓	✓	✓	✓
Omnisports Extreme	✓	✓	✗	✓	✓
Omnisports Compact & HPL	✗	✗	✗	✓	✓

* For all systems, please review current installation recommendations for additional information regarding substrates, conditions, and methods. Some substrates may require additional or alternative treatments prior to the application of floor covering. Compatible substrates include: properly constructed and prepared concrete, wood, asphalt, and cementitious underlayments. Refer to current installation guidelines, ASTM F710, ACI 302.2R, and other industry publications including accessories for more information. Hot Yoga and Radiant Heated Slabs should use either Multi-Poxy or Tarkolay systems as conditions require. *RH is measured per ASTM F2170. *MC is measured per ASTM F2659 for Surface and Impedance Probe.

TARKOLAY

Every flooring installation is different. In some cases, high moisture, cracks, joints or other factors present challenges that require an underlayment. Tarkolay is a FloorScore-certified underlayment that isolates the flooring system away from the substrate, removing the potential for vapor pressure to form. Tarkolay also assists with installations over moving joints, minor cracks in concrete substrates, and existing surfaces that are adverse to standard installation methods. Only Multi-Poxy adhesive may be used with Tarkolay.

1. ISOLATION OF THE SPORTS SURFACE

Tarkolay mitigates adverse conditions by separating the sports surface from the subfloor. Through isolation, an imperfect subfloor is less likely to affect the integrity of the surface installation.

2. DIMENSIONALLY STABLE UNDERLAYMENT

Tarkolay is a dimensionally stable underlayment with a smooth top surface for excellent adhesion to the sports floor.

3. RAISED TEXTURE FOR DISPERSING WATER VAPOR

The embossed texture on the bottom of Tarkolay allows water vapor from the subfloor to dissipate without building pressure that would harm the integrity of the installation.

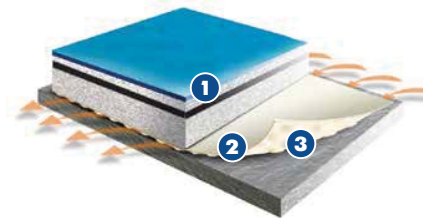

GREENLAY

GreenLay has revolutionized sports flooring installations as the new standard of performance and environmental responsibility. In an 8,000-square-foot gymnasium, less than one gallon of adhesive is used compared to nearly 64 gallons for a full-spread installation.



HOW IT WORKS

GreenLay uses small amounts of adhesive along the parallel walls of the court, in doorways and around volleyball sleeves, while Tarkotape from Tarkett secures each seam for welding. The Omnisports material does the rest with its excellent dimensional stability and virtually tension-free manufacturing process to make it the only resilient sports flooring that can be installed this way. In short, the superior quality of Omnisports makes GreenLay possible.



TARKETT MULTI-POXY

Tarkett Multi-Poxy is a specially formulated 2 component adhesive system for the installation of Tarkett Indoor Sports Flooring over porous and non-porous substrates. When part A and B are thoroughly mixed together and used as recommended, they form a reactive adhesive that cures to a tough, flexible film with excellent surface moisture resistance and adhesion to many difficult-to-bond-to substrates. Multi-Poxy is packaged in 4 gallon kits. Part A is packaged in a 5 gallon container allowing for ease of mixing. Part B is packaged in a 2 gallon container and can be poured directly into the Part A container, or partial mixing can be easily accomplished in separate containers with a mix ratio of 1:1.

- Highly recommended
- Highly recommended with Lumaflex sub-construction
- Suitable

	OMNISPORTS						
	COMPACT	SPEED	HPL	MULTI-USE	ACTIVE+	PUREPLAY	EXTREME
		p. 22	p. 22, 24	p. 24	p. 26	p. 26	p. 28
Multi-sports	○	●	●	●	●	●	●
Multi-use	○	●	●	●	●	●	●
Basketball	○	●	●	●	●	●	●
Volleyball	○	●	●	●	●	●	●
Handball	○	●	●	●	●	●	●
Futsal	○	●	●	●	●	●	●
Table tennis		●	●	●	●	●	●
Badminton		●	●	●	●	●	●
Pickleball	○	●	●	●	●	●	●
Fitness - aerobics	○		●	●	●	●	●
Fitness - cardio (bikes, treadmills, rowing machines,...)		●	●				
Wellness centers		●	●				
Roller sports and handisports	○		●				
Yoga			●		●	●	●
Traffic areas (corridors, entrance halls, meeting rooms,...)	●		●				

TECHNICAL DATA

CERTIFICATION & CLASSIFICATION	STANDARD	COMPACT	SPEED	HPL 7	HPL 9	MULTI-USE	ACTIVE+	PUREPLAY	EXTREME
Ball Rebound	ASTM F2772-11	See HPL Data	Passed	Passed	Passed	Passed	Passed	Passed	Passed
Force Reduction	ASTM F2772-11	See HPL Data	Class 1	Class 1	Class 2	Class 2	Class 3	Class 3	Class 4
Surface Finish Effect	ASTM F2772-11	See HPL Data	Passed	Passed	Passed	Passed	Passed	Passed	Passed
Vertical Deformation	ASTM F2772-11	See HPL Data	Passed	Passed	Passed	Passed	Passed	Passed	Passed
Below-Room Sound Insulation	ISO 717/02	N/A	20 dB	N/A	N/A	21 dB	21 dB	21 dB	21 dB
In-Room Sound Insulation	(NF S31-074	N/A	Class A <65dB	N/A	N/A	Class A <65dB	Class A <65dB	Class A <65dB	Class A <65dB
Microbial Resistance	ASTM G21	No Growth	No Growth	No Growth	No Growth	No Growth	No Growth	No Growth	No Growth
Reaction to Fire	ASTM E648	Class 1 (Radiant Panel)	Class 1 (Radiant Panel)	Class 1 (Radiant Panel)	Class 1 (Radiant Panel)	Class 1 (Radiant Panel)	Class 1 (Radiant Panel)	Class 1 (Radiant Panel)	Class 1 (Radiant Panel)
Resistance to Impact	EN 1517	No Degradation	No Degradation	No Degradation	No Degradation	No Degradation	No Degradation	No Degradation	No Degradation
Rolling Load	EN 1569	See HPL Data	≤ 1.0 mm (No Degradation)	≤ 0.5 mm (No Degradation)	≤ 0.5 mm (No Degradation)	≤ 0.5 mm (No Degradation)	≤ 0.5 mm (No Degradation)	≤ 0.5 mm (No Degradation)	≤ 0.5 mm (No Degradation)
Roll Length	EN 426/EN 427	26 m (85.3')	23 m (75.5')	26 m (85.3')	26 m (85.3')	26 m (85.3')	26 m (85.3')	26 m (85.3')	15 m (49.2')
Roll Width	EN 426/EN 427	2 m (6.5')	2 m (6.5')	2 m (6.5')	2 m (6.5')	2 m (6.5')	2 m (6.5')	2 m (6.5')	2 m (6.5')
Stain Resistance	ASTM F925	Excellent	Excellent	Excellent	Excellent	Excellent	Excellent	Excellent	Excellent
Static Load Tolerance	ASTM F970	See HPL Data	175 psi	500 psi	500 psi	175 psi	175 psi	175 psi	N/A
Taber Abrasion	ASTM D3389	0.02 g (1,000 Cycles)	0.02 g (1,000 Cycles)	0.02 g (1,000 Cycles)	0.02 g (1,000 Cycles)	0.02 g (1,000 Cycles)	0.02 g (1,000 Cycles)	0.02 g (1,000 Cycles)	N/A
Thickness	EN 428/EN 429	2.0 mm (0.079")	3.5 mm (0.138")	7 mm (0.276")	9 mm (0.354")	6.2 mm (0.244")	8.1 mm (0.319")	9.4 mm (0.37")	12 mm (0.47")
Wear Layer Performance Grade	ASTM F1303	Type 1, Grade 1, Commercial	Type 1, Grade 1, Commercial	Type 1, Grade 1, Commercial	Type 1, Grade 1, Commercial	Type 1, Grade 1, Commercial	Type 1, Grade 1, Commercial	Type 1, Grade 1, Commercial	Type 1, Grade 1, Commercial
Wear Layer Structure		2.0 mm (0.079")	2.0 mm	2.0 mm	2.0 mm	2.0 mm	2.0 mm	2.0 mm	2.0 mm
Wear Layer Thickness	ASTM F410/F1303	0.7 mm	0.65 mm	0.7 mm	0.7 mm	0.7 mm	0.7 mm	0.7 mm	0.76 mm
Weight	EN 430	3.1 kg/m ² (0.64 lbs./sq.ft)	3.29 kg/m ² (0.67 lbs./sq.ft)	0.8 lbs./sq.ft. HPL	1.12 lbs./sq.ft. HPL	3.95 kg/m ² (81 lbs./sq.ft)	4.7 kg/m ² (0.96 lbs./sq. ft.)	5.7 kg/m ² (1.17 lbs./sq.ft.)	7.1 kg/m ² (1.45 lbs./sq.ft.)

The above information is subject to modification for the benefit of further improvement. (01/2021). Tarkett Sports' instructions regarding installation, cleaning and maintenance should be observed. Please contact Tarkett for these instructions.





THE TARKETT SPORTS FAMILY - LEADERS IN SPORTS SURFACING



SCAN ME

888-364-6541

tarkettsportsindoor.com





POLYTURF PLUS PAD & POUR

PROVEN DURABILITY



**IT'S ONE
THING TO BE
A PLAYER.
IT'S ANOTHER
TO CHANGE
HOW THE
GAME IS
PLAYED.**



AN INDUSTRY LEADER

Tarkett Sports is a division of the Tarkett Group, which was established in 1886. The knowledge and expertise accrued by Tarkett over 130 years has made it one of the largest flooring manufacturers in the world.

With over \$2.5 Billion in annual sales and an average of 13 million square feet of flooring produced per day, Tarkett is a global leader in commercial, residential, and sports solutions.



BUILT STRONGER, TOGETHER

Tarkett Sports does it all. We offer a full range of surfacing products. From our line of commercial, residential and athletic artificial turf, sports tracks, and indoor flooring, we have the right solution to fit your needs. Tarkett Sports is built stronger, together.



WHY TARKETT SPORTS



TARKETT SPORTS BRAND

Tarkett Sports is a world leader in athletic surfacing, offering a comprehensive portfolio of sports flooring solutions through its brands: FieldTurf, Beynon Sports, Renner Sports, EasyTurf, Desso, GrassMaster, PlayMaster and Tarkett Sports Indoor.



DESIGN & CONSTRUCTION EXPERTS

Tarkett Sports and our partners are some of the most experienced and knowledgeable teams in the industry. When it comes to the design and construction of your sports surface, we are the experts.



FINANCIALLY STABLE

The Tarkett Group is a worldwide leader of innovative flooring and sports surface solutions. Tarkett Sports Indoor is backed by unprecedented financial support and stability. You can rest easy.



LEADING DURABILITY

Manufactured and installed with the highest attention to detail, Tarkett Sports Indoor's systems showcase proven durability.



EXPERIENCE

With over 5,000 installations in North America in the last 10 years, Tarkett Sports Indoor has the knowledge and expertise to make your sports facility a success.



TRUSTED

For indoor facilities, Tarkett Sports Indoor offers the most trusted sports flooring for various style facilities in North America.



ENDLESS PURSUIT OF INNOVATION

From the Dropzone rubber, PolyTurf Plus Pad & Pour system, Omnisports vinyl sports flooring, ClutchCourt wood, and EcoPure linoleum, our innovation and versatility extend beyond just sports. We're there to support your team.



SERVICE

We are as committed to your program as you are, and we're with you for the long term. When you buy from Tarkett Sports, you're buying from a company that knows how to take care of you.

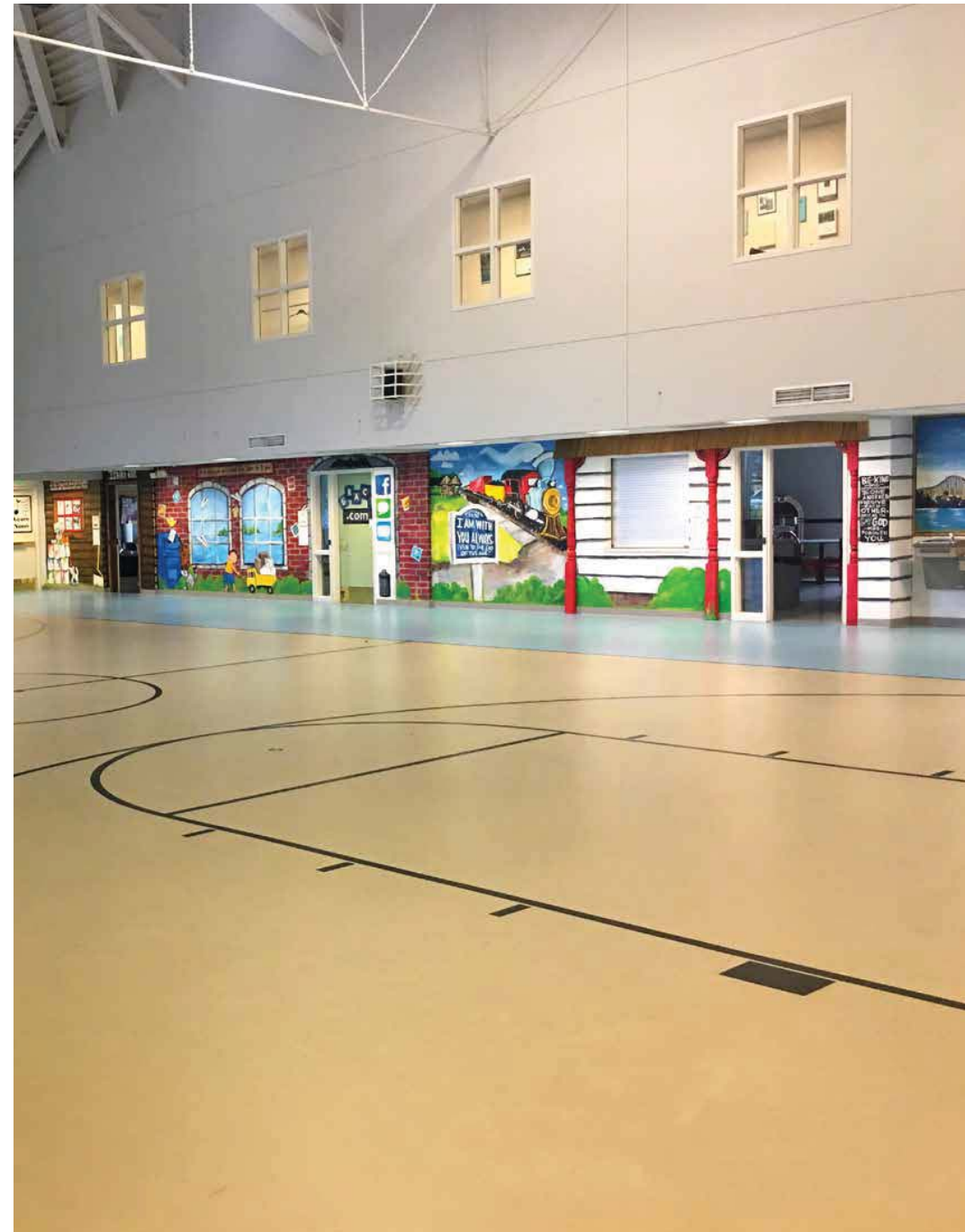

A TURNKEY SOLUTION

WITH TARKETT SPORTS INDOOR

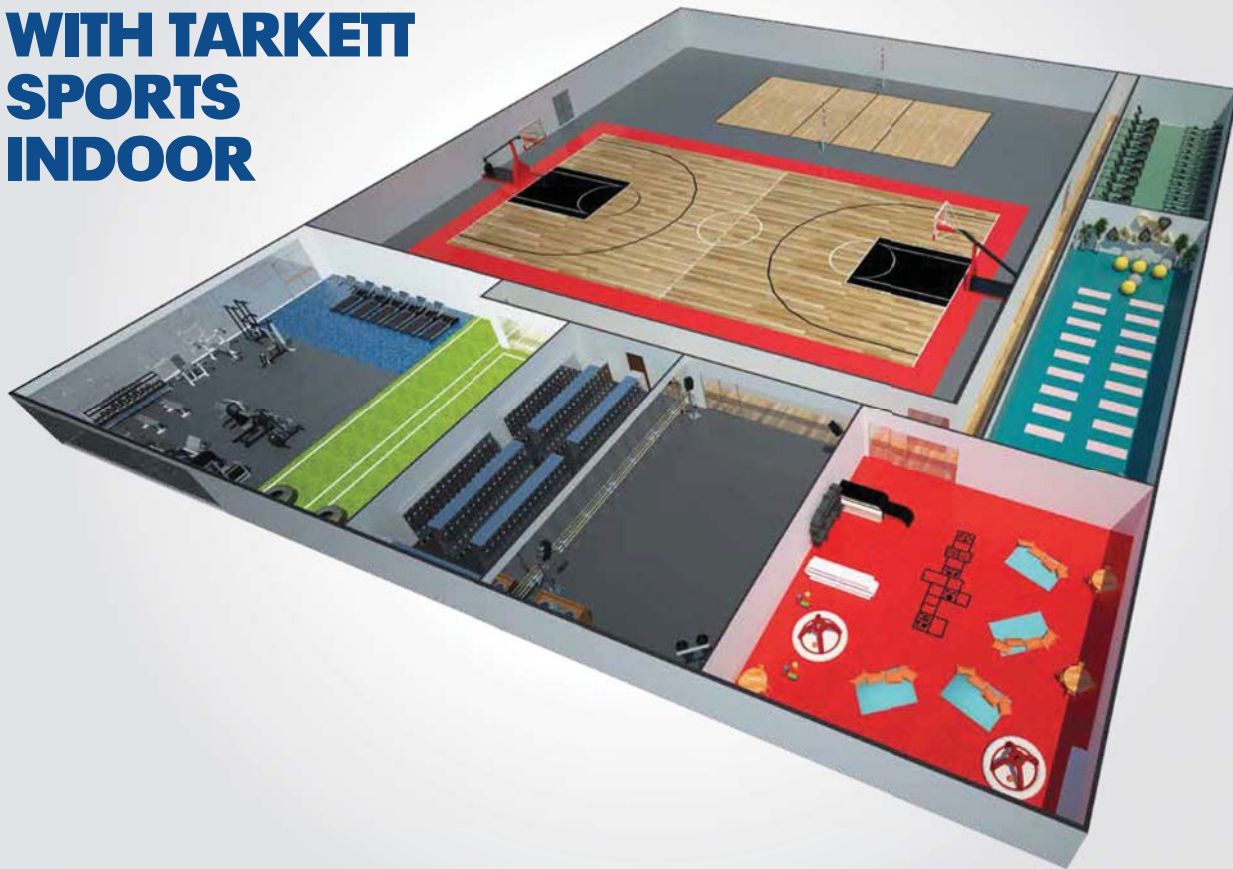

OMNISPORTS

The Game-Changing versatility of Omnisports

Applications: Gymnasium • Daycare • Multi-Purpose Rooms • Cafetorium • Yoga • Martial Arts



DROPZONE

The surface strength of Dropzone rubber flooring

Applications: Weight Rooms • Strength & Cardio Equipment • Spinning • Training Turf • Functional & Extreme Training • Ice Rinks



CLUTHCOURT

Inspiring tradition of ClutchCourt Northern Maple

Applications: Gymnasium (Basketball & Volleyball) • Aerobics • Racquetball

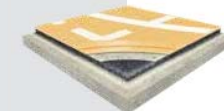

POLYTURF PLUS PAD & POUR

The seamless playing surface of PolyTurf Plus Pad & Pour

Applications: Multi-Purpose Rooms • Cafetorium • Gymnasium • Inline Skating

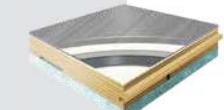

LUMAFLEX

The pinnacle of sports performance with Lumaflex

Applications: Gymnasium • Multi-Purpose Rooms • Inline Skating • Aerobic and Fitness



DANCEFLOOR

Perform at your best with Dancefloor

Applications: Dance Studio • Dance Stage



ECOPURE

The natural sustainability of EcoPure Linoleum

Applications: Multi-Purpose Rooms • Gymnasium • Daycare

MAKE THE GAME-WINNING CHOICE AND CHOOSE TARKETT SPORTS

The Tarkett Sports approach to indoor sports flooring is to be a knowledge resource for all sports facility stakeholders and provide the right flooring solutions for the needs and values of our customers. To accomplish this, we offer a wide range of gym flooring options, suitable for many different activities and level of competition.



HEALTH AND THE ENVIRONMENT

PolyTurf Plus Pad & Pour embodies Tarkett's four categories of sustainability.

- Contains natural materials
- No heavy metals or formaldehyde
- Uses rapidly renewable materials
- Low VOC emissions
- GREENGUARD Gold certified
- Requires no harsh chemicals to maintain
- Utilizes no solvents
- Contains recycled content
- Allows potential overlay
- 100% recyclable
- Recycled content helps divert material from landfills



A HIGHER STANDARD OF INDOOR AIR QUALITY

Children are more sensitive to poor indoor air quality than adults. For them, a higher standard of health and safety is needed. GREENGUARD Gold identifies flooring that goes above and beyond typical indoor air quality standards, exceeding the requirements of California Section 01350. It is recognized by the CHPS Best Practice Manual for K-12 Schools and the LEED building rating system. As a GREENGUARD Gold floor, PolyTurf Plus Pad and Pour offers recognized protection for those most sensitive to poor indoor air quality. Choose PolyTurf Plus Pad & Pour for more than just a sports floor. Choose it for peace of mind.



The **mindful MATERIALS** Library is a searchable database where users can find architectural building products that have various transparency and sustainability attributes. You can now find numerous Tarkett Sports' products in the **mindful MATERIALS** Library.



MANUFACTURED IN AMERICA

Tarkett's Beynon Sports Surfaces controls all aspects of the manufacturing chain, which allows us to create the right product, regardless of the facility. Because Beynon's founder's name stands behind their products, we take special care throughout the entire installation process.



DESIGN

PolyTurf Plus Pad & Pour is proudly American made. We provide a seamless polyurethane structural layer that is strong, and durable. Its design and appearance are simple; its performance is anything but.



FORMULATION

Our philosophy on materials selection is simple: use only the best environmentally friendly, bio-based raw materials because we understand that the material choices we make today will affect your athletes for years to come.



MANUFACTURING

PolyTurf Plus Pad & Pour is manufactured by Tarkett's Beynon Sports Surfaces, an ISO 14001 certified manufacturer in Hunt Valley, Maryland, USA. This ensures a level of quality and consistency in production.



INSTALLATION

With an exceptionally quick curing rate, PolyTurf Plus Pad & Pour can be installed and ready to use in a relatively short time frame.

NOT ALL WARRANTIES ARE CREATED EQUAL

REST EASY WITH TARKETT SPORTS 30 YEAR WARRANTY

Peace of mind is what we strive for. When you choose PolyTurf Plus Pad & Pour by Tarkett Sports for your facility or multi-purpose room, you get peace of mind for 30 years.



10 YEARS MOISTURE RESISTANCE

When you choose PolyTurf Plus Pad & Pour and install with our dimensionally stable underlayment, Tarkolay, you get an additional 10 Years Warranty for Moisture Resistance. Tarkolay comes with Moisture Resistance up to 100% RH. No other polyurethane on the market can compete.



PROVEN WINNING TRACK RECORD

Tarkett Sports is a division of the Tarkett Group, which has been in operation since 1886. Beynon Sports, a department within the Tarkett Sports Division has been manufacturing in the USA and installing polyurethane in North America for more than 40 years. Tarkett Sports has over 500 PolyTurf Plus Pad & Pour installations in North America.

WHAT'S COVERED IN THIS WARRANTY?

When we say "peace of mind", we mean it. We are offering a 30 year warranty on the following:

- Manufacturing defects
- Delamination of the layers
- Deterioration of the recycled rubber base mat
- Reversion or re-liquefying of any layer
- Separation of the seams within the base mat

CUT OUT THE MIDDLE MAN

When choosing Tarkett Sports' PolyTurf Plus Pad & Pour, you deal directly with the manufacturer. When not dealing directly with a manufacturer, it is difficult to know what can happen in 10-20 years. For this reason, when Tarkett Sports provides a 30-year warranty, we mean it.

Why?

The Tarkett Group has been in business for over 135 years, selling over 13 million Sq. Ft. of flooring per day. When you choose PolyTurf Plus Pad & Pour, it comes with a 30-year warranty from a manufacturer, eliminating the risks associated with the unknown.

POLYTURF PLUS PAD & POUR

APPLICATIONS

MULTI-USE GYMNASIUMS

- Elementary Schools
- Middle Schools
- High Schools
- Colleges and Universities
- Community Centers

OTHER APPLICATIONS

- Fieldhouses
- Military Training Facilities
- Recreational Facilities
- Multi-Use Areas
- Inline Skating

BENEFITS

Seamless Surface:

PolyTurf Plus Pad & Pour offers seamless gym flooring that is not only visually simplistic but also imparts the practical cleaning benefits of having no seams

Extreme Toughness:

PolyTurf Plus Pad & Pour is designed to withstand the harshest treatment, whether it be high point loads like folding cafeteria tables and portable stages, rolling loads like portable bleachers, or just heavy traffic and sports activity

Fast Installation Time:

With an exceptionally quick curing rate, PolyTurf Plus Pad & Pour can be installed and ready to use in a relatively short time frame

Permanent Performance:

Renewable wear layer can be recoated at any time, indefinitely

Superior Load Tolerances:

PolyTurf Plus Pad & Pour performs under the everyday use of tables, chairs and bleachers

ISO 14001 Manufacturing:

PolyTurf Plus Pad & Pour is manufactured in America by Tarkett's Beynon Sports Surfaces, an ISO 14001 certified manufacturer. This ensures a high level of quality and consistency in production

Tarkett Sports

Warranty Protection:

The quality and performance of PolyTurf Plus Pad & Pour is protected by Tarkett Sports with a comprehensive 30 year warranty

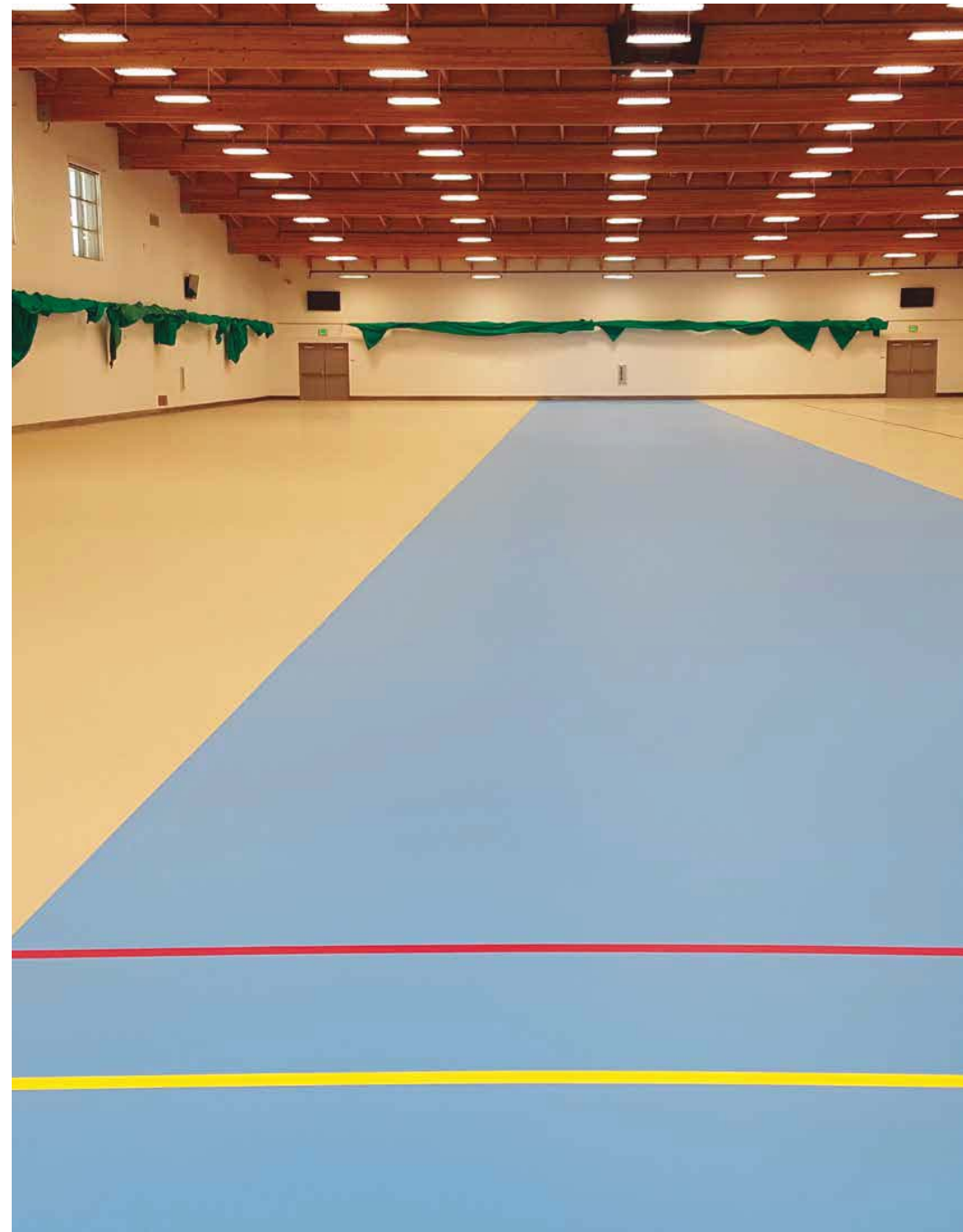



ASTM F2772

THE SPORTS FLOORING STANDARD

In areas designated for sports, flooring should be optimized for physical activity. ASTM F2772 measures four key factors regarding safety and suitability for sports activities:

- Force Reduction
- Ball Rebound
- Surface Finish Effect
- Vertical Deformation

FORCE REDUCTION (SHOCK ABSORPTION)

ASTM F2772 separates degrees of force reduction into five classes to assist in determining the appropriate level for specific sports or other activities. ASTM F2772 also establishes a minimum value of 10% force reduction for any floor space designed for indoor athletics or physical recreation.

POLYTURF PLUS PAD & POUR SPORTS PERFORMANCE

PolyTurf Plus Pad & Pour meets all the requirements of ASTM F2772, including force reduction, ball rebound, surface finish effect, and vertical deformation.

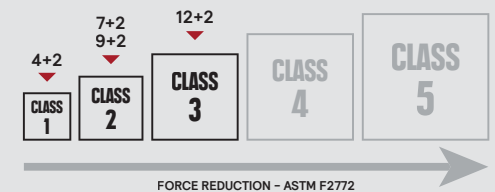

POLYTURF PLUS PAD & POUR

FEATURES

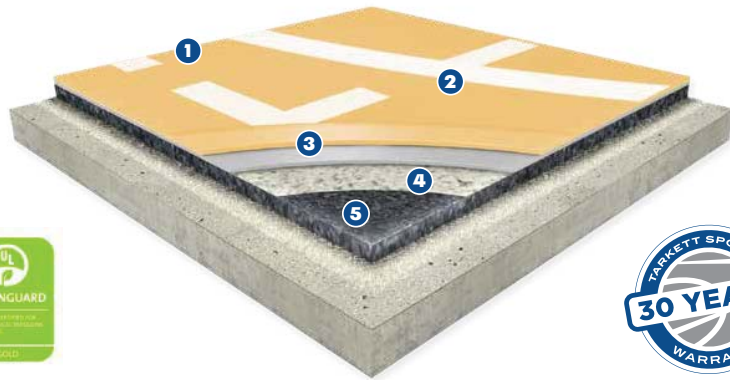

- 1 Water-Based Aliphatic Coating**
This spray or roller-applied coating provides optimal game performance and stain resistance.
- 2 Chemically Bonded Game Lines**
Meticulously applied polyurethane marking paint creates precise and permanent game lines.
- 3 Formulated Elastomeric Resin**
This resin layer provides exceptional ball rebound and extra durability.
- 4 Two-Component Seal Layer**
The primary characteristic of PolyTurf Plus Pad and Pour is its seamless playing surface. This coating layer seals shock pad pores for a smooth and seamless gym floor.
- 5 Recycled Rubber Shock Pad**
Made of 100% recycled rubber, this shock pad base layer provides cushioning and shock absorption and is available in multiple thicknesses.

STANDARD SURFACE COLOR SELECTION

Tarkett Sports offers more color options for PolyTurf Plus Pad & Pour than any other pad and pour system on the market, allowing more customization for your gym floor.

PolyTurf Plus Pad & Pour comes in 8 standard colors, with additional custom options available.

GAME LINE COLORS

PolyTurf Plus Pad & Pour comes with 8 game line colors with additional custom options available.

FORMAT OPTIONS

4 Shock Pad Options:
4 mm, 7 mm, 9 mm, 12 mm

SPORT APPLICATIONS

- BASKETBALL
- VOLLEYBALL
- TENNIS
- WEIGHT ROOM

POLYTURF PLUS PAD & POUR

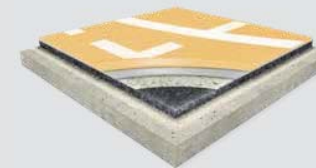

- SPIKE RESISTANT
- ★★★★★☆
- ★★★★★☆
- ★★★★★☆
- ★★★★★☆

POLYTURF PLUS PAD & POUR WITH A LUMAFLEX SYSTEM



- SPIKE RESISTANT
- ★★★★★★
- ★★★★★★
- ★★★★★★
- ★★★★★★

POLYTURF PLUS PAD & POUR

WITH LUMAFLEX

ELEVATE YOUR GAME TO ANOTHER LEVEL

The Lumaflex and Lumaflex Elite systems upgrade your PolyTurf Plus Pad & Pour floor by adding a layer of 18 mm plywood planks that are made exclusively from birch. The 18 mm plywood planks are placed above shock-absorbing foam or the premium elite cushion, which provide the pinnacle of performance, safety, comfort and uniform structural support.

Lumaflex combines point-elastic surface properties with an area-elastic substructure.

BENEFITS

Multi-Use functionality: Lumaflex adds multi-use functionality and comfort to the ultimate sports flooring system.

Reliable Bonding And Assembly: Each plywood plank incorporates an interlocking tongue-and-groove edge for fast and reliable installation.

Lumaflex Shock-Absorbing Foam Or Premium Elite Cushion: Regardless of the Lumaflex system, they can be modified to meet height requirements, especially when replacing a wood floor within an existing recessed slab.



LUMAFLEX
Class 4 per ASTM F2772

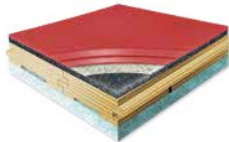

LUMAFLEX ELITE
Class 5 per ASTM F2772

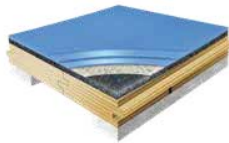

By engaging the athlete with these two types of elasticity, Lumaflex simultaneously responds in the immediate area of impact and across a wider surface area. This combined response generates remarkably high levels of shock absorption and natural stability underfoot.

With a Lumaflex system, you can train, practice and play for longer periods of time with less fatigue and more comfort.

THE RIGHT FLOOR FOR COMBINING HIGH-LEVEL SPORTS WITH SCHOOL EVENTS

"We chose the combination system really for two main reasons, the first being that we wanted a floor that performed like – if not better – than wood. Secondly, we wanted a system that required limited maintenance. So when you put those two things together, the combination system was the ideal solution for us. It's easy to maintain, and we get great use of a surface that performs as well as any surface I've used."

BRYAN NIXON
HEAD OF SCHOOL, WHITBY SCHOOL
GREENWICH, CONNECTICUT

POLYTURF PLUS PAD & POUR

WITH TARKOLAY

Every flooring installation is different. In some cases, high moisture, cracks, joints, or other factors present challenges that require an underlayment. Tarkolay separates the flooring system away from the slab, removing the ability for vapor pressure to form. Tarkolay can also assist with challenges over other concrete imperfections at the surface.

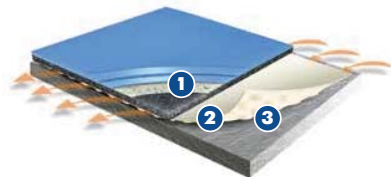

1. ISOLATION OF THE SPORTS SURFACE

Tarkolay mitigates adverse conditions by separating the sports surface from the subfloor. Through isolation, an imperfect subfloor is less likely to affect the integrity of the surface installation.

2. DIMENSIONALLY STABLE UNDERLAYMENT

Tarkolay is a dimensionally stable underlayment with a smooth surface for excellent adhesion to the sports floor.

3. RAISED TEXTURE FOR DISPERSING WATER VAPOR

The embossed texture of Tarkolay allows water vapor from the subfloor to dissipate without building pressure that would harm the integrity of the installation.

UP TO
10 YEARS
MOISTURE
RESISTANCE
WARRANTY
UP TO 100% RH



**NO
MOISTURE
TESTING
REQUIRED**

PERFORMANCE

Tarkolay can address concrete moisture conditions and does not require any initial moisture testing. It is also a FloorScore® certified underlayment that can resolve high moisture and other issues while still maintaining the highest standard of indoor air quality.

HEALTH & THE ENVIRONMENT

Tarkolay embodies four categories of sustainability, providing not only superior performance, but stewardship of the environment and care for individual health.



GOOD MATERIALS

- No REACH restricted chemicals
- No formaldehyde



RESOURCE STEWARDSHIP

- ISO 14001 manufacturing
- Tarkett's history of conservation



PEOPLE-FRIENDLY SPACES

- FloorScore® certified



REUSE AND RECYCLE

- Recyclable material*

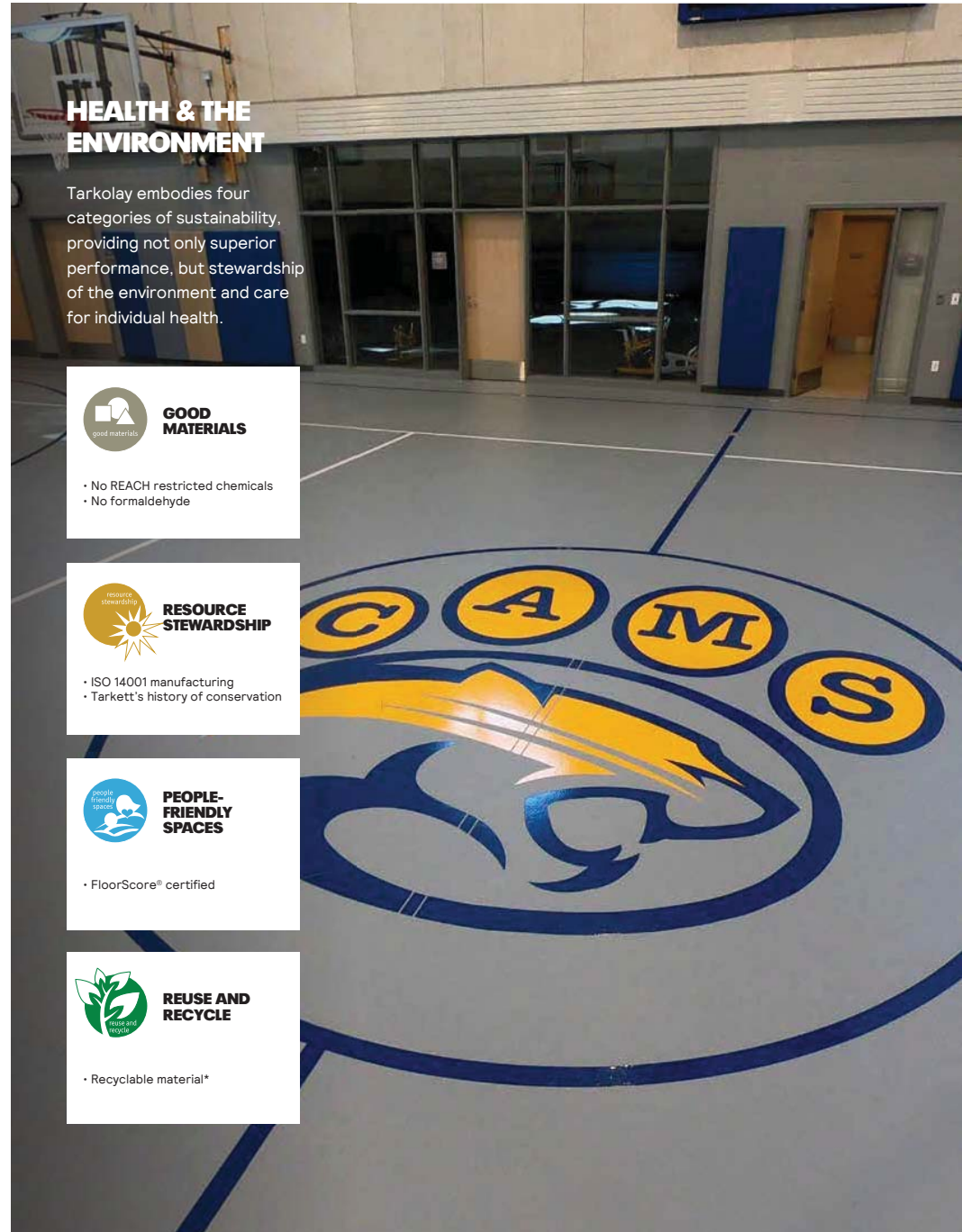

PUT YOUR DREAM INTO MOTION

INSTALLING YOUR NEW COURT MIGHT BE EASIER THAN YOU THINK

Through a partnership with PNC Sports Finance, a business unit of PNC Equipment Finance, LLC, Tarkett Sports now offers payment solutions customized to your specific budget requirements. Low fixed-rate financing is available for qualified customers in public, private and non-profit sectors. Financing is also available for purchases made through the SmartBuy program, which includes prominent cooperative purchasing agencies.

BENEFITS OF TARKETT SPORTS FINANCIAL SOLUTIONS

STAY WITHIN YOUR BUDGET:

Spread the costs over customized periodic payments that match your budget timeline.

START SEEING RESULTS NOW:

Generate savings and revenue while payments are made.

TAKE ADVANTAGE OF CUSTOMIZED SOLUTIONS:

Choose an option that fits, including municipal solutions that meet appropriation requirements.

GET GREAT RATES WITH FAST AND EASY APPROVAL PROCESS:

Finance your athletic surfaces quickly, easily and with highly competitive rates.

SAVE FUNDS FOR OTHER NEEDS:

Stretch total project budgets that incorporate design, construction and other costs.

PRESERVE BANK CREDIT LINES:

Financing will not affect your bank credit line, saving credit for needs such as working capital.

THERE'S A STREAMLINED, COST-EFFICIENT WAY TO BUY SPORTS SURFACES

The SmartBuy Cooperative Purchasing Program gives you access to several different cooperatives that are competitively bid and awarded based on a rigorous evaluation process. Tarkett can help you determine which one is best for you, and all costs and services are identified.

Through these cooperatives, customers can purchase Tarkett Sports indoor flooring across the US on previously bid contracts with preferential pricing. Turnkey solutions are available with these cooperatives through the alternative costing method, RSMMeans and the OC unit price book.

THE SMARTBUY COOPERATIVE PURCHASING PROGRAM PROVIDES A WINNING STRATEGY FOR PURCHASING A NEW SPORTS FLOOR.

- Simplified ordering process
- Prevents duplication of the bid process
- Provides access to the industry's best products
- Guaranteed "best value" through the cooperative system
- Satisfies bid laws and procurement processes in most states
- The fastest proposal-to-contract process
- Gives owners project control
- Turnkey product solutions



THE RIGHT OPTION

OVER 500 POLYTURF PLUS PAD & POUR INSTALLATIONS

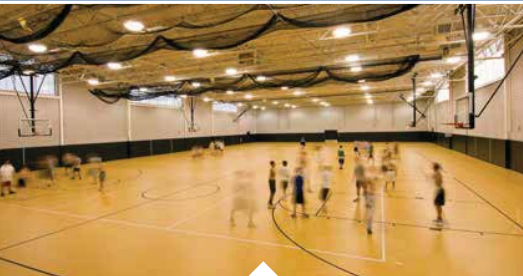

MCQUAID FIELDHOUSE
Rochester, NY
Installed in 2007

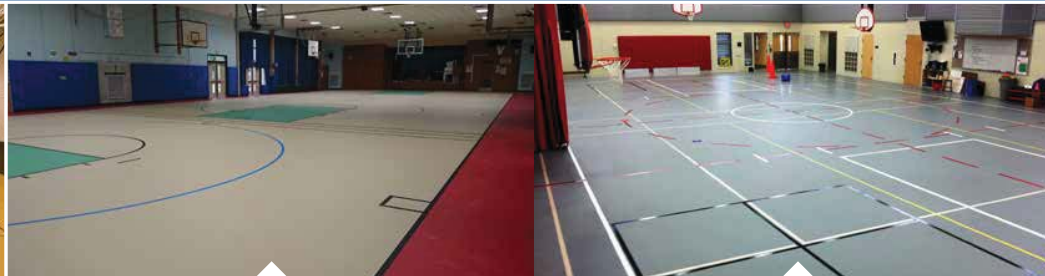

IDLE HOUR ELEMENTARY SCHOOL
Oakdale, NY
Installed in 2016



BRIDGEWOOD PUBLIC SCHOOL
Cornwall, ON
Installed in 2014

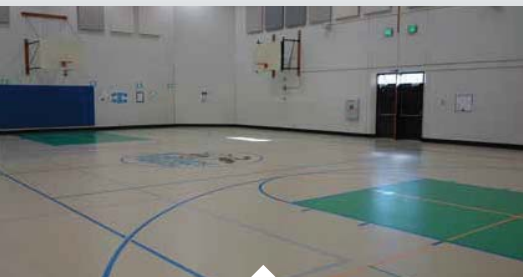

PARKWAY MONTESSORI AND COMMUNITY MIDDLE SCHOOL
St. Paul, MN
Installed in 2014



HILLSIDE ELEMENTARY SCHOOL
Hastings-on-Hudson, NY
Installed in 2016



KNICKREHM ELEMENTARY
Grand Island, NE
Installed in 2013



BLUM ISD
Blum, TX
Installed 2017

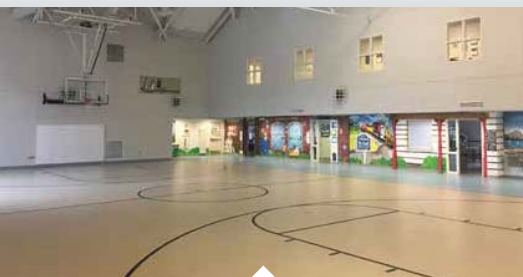

WAYZATA COMMUNITY CHURCH
Wayzata, MN
Installed in 2015



EASTON OLYMPIC TRAINING
Chula Vista, CA
Installed in 2017



AMHERST MIDDLE SCHOOL
Amherst, VA
Installed in 2016



LAKE HEALTH MENTOR HEALTH AND WELLNESS CENTER
St. Mentor, OH
Installed 2017



**TEAM UP WITH
POLYTURF PLUS
PAD & POUR
TO BRING
YOUR GAME
TO ANOTHER
LEVEL**





THE TARKETT SPORTS FAMILY - LEADERS IN SPORTS SURFACING



888-364-6541 | tarkettsportsindoor.com



CLUTHCOURT

A Tradition of
Competitive
Perfection



Embrace the traditions of the game.

Compete to win on **CLUTCHCOURT.**

Every game has traditions that span generations of players. Basketball at the highest levels of competition will always be played on maple hardwood courts with personalities as unique as the teams that play on them. ClutchCourt embodies the history of the game, while at the same time embracing Tarkett Sports' innovative design approach developed over 130 years of flooring manufacturing.

ClutchCourt is MFMA northern hard maple installed in a variety of systems to meet the needs of any level of competition. The Trainer Series provides the beauty of a maple surface without overwhelming your budget. The Performance Series takes the game up a notch, with higher shock absorption, more consistent game play, and the patented Flexlock Panel system. When the game is on the line, coaches always turn to a clutch player. When your court needs to be the best, choose ClutchCourt.



Trainer Series

Trainer 1, Trainer 2, and Trainer 3
Pages 6-7

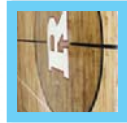

Fitness

Gymnasiums

Competitive Basketball and Volleyball

Aerobics

Performance Series

Performance, Performance Anchor,
Performance Anchor Channel, and Flexlock Panel
Pages 4-5

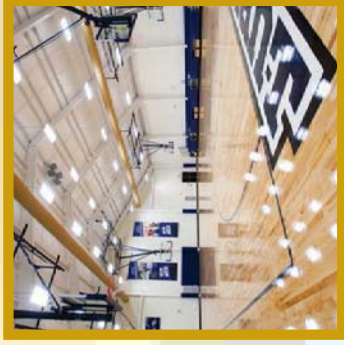

ClutchCourt Performance Series



The ClutchCourt Performance Series represents maple courts at their best. From the MFMA PUR Compliant Performance system to the more stable Anchor and Anchor Channel systems to the Flexlock Panel, these surfaces are built for the highest levels of competition.



Performance

The Performance system incorporates plywood and a 3/4" CoreCushion pad that gives it Class 5 shock absorption per ASTM F2772. This system is MFMA PUR Compliant and is designed for all levels of competition. Performance is the most widely used ClutchCourt flooring system for basketball, volleyball, and aerobics.



Performance Anchor

Performance Anchor is similar to the Performance system, with the added stability of a fully anchored subfloor. This system is ideal for facilities larger than 12,000 square feet. Performance Anchor is also available in a low-profile variation for circumstances where the height of flooring systems is restricted.



Performance Anchor Channel

The Performance Anchor Channel system is a patented fixed system with resilient channel inserts, made with recycled rubber and no floating components. It gives a solid feel underfoot without overly compromising shock absorption. This system is also available with steel reinforcement for added dimensional stability.



Flexlock Panel

The Flexlock Panel system incorporate a patented diagonal subfloor design for ventilation. Because they are constructed from lightweight 4' x 8' floating panels, installation is both fast and easy. They provide Class 4 shock absorption properties through either a 1/4" or 1/2" resilient foam pad underneath the entire system.

Your Dream Court is Closer than You Think

Whether it is attracting new spectators, securing sponsorships, or hosting tournaments, a new ClutchCourt surface has the potential to create revenue. Why wait to get the return on your investment? Through a partnership with PNC Sports Finance, a business unit of PNC Equipment Finance, LLC, Tarkett Sports now offers payment solutions customized to meet your specific budget requirements. Financing is available for qualified customers including public, private, and non-profit organizations. Financing is even available for purchases made through the Smart Buy program, which includes cooperative purchasing agencies such as AEPA, TCPN, Buy Board, NJPA, and KPN. Get the game started with this exclusive financing solution.



Sports Performance

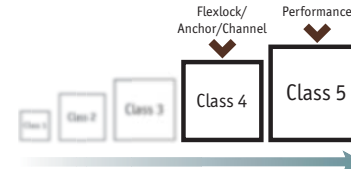

The Performance Series meets all the requirements of ASTM F2772, including force reduction, ball rebound, surface finish effect, and vertical deformation.



Health and the Environment

The ClutchCourt Performance Series embodies four categories of sustainability, providing not only superior sports performance, but stewardship of the environment and care for individual health.



• Made from natural materials



• FSC® Chain of Custody Certification
• Selective harvesting
• Timber replacement program



• Low VOC finishes and paints



• Maple can be repurposed

ClutchCourt Trainer Series



The ClutchCourt Trainer Series is your introduction into the world of premium maple sports flooring. All courts have an MFMA northern maple surface, which is available in three grade classifications. Each system is supported by sleepers, plywood, or a combination of the two.

Trainer 1



Trainer 1 is designed as a value-driven hardwood system that is easy to install. Its 3/8" shock pads provide the shock absorption needed for the comfort and safety of athletes. Trainer 1 is intended for facilities seeking moderate performance levels at a low cost.

Trainer 2



Trainer 2 adds a layer of 15/32" plywood on top of treated sleepers. This layer increases the dimensional stability of the system. For additional stability, Trainer 2 can be secured to the subfloor as a fixed system.

Trainer 3



Trainer 3 accommodates high levels of activity and traffic. With two layers of 15/32" plywood, the system is designed to be the most durable and stable of the Trainer systems. Trainer 3 utilizes 3/8" shock pads to provide shock absorption for comfort and safety.

Accountable Every Step of the Way

Transparency is a key part of sustainable manufacturing. Through certification with the Rainforest Alliance, all ClutchCourt systems can be purchased with FSC® Chain of Custody certification. This certification examines every step in the manufacturing process and verifies that it is performed according to specific standards outlined by the Forest Stewardship Council®. Every procedure from harvesting and milling to transportation is thoroughly analyzed to confirm that each stage reflects sustainable practices. When you choose ClutchCourt, you can have the peace of mind that your court was produced in an environmentally responsible way.

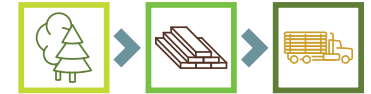

Sports Performance

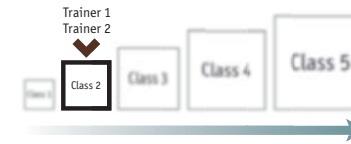

ClutchCourt Trainer 1 and 2 meet all the requirements of ASTM F2772, including force reduction, ball rebound, surface finish effect, and vertical deformation.



Health and the Environment

The ClutchCourt Trainer Series embodies four categories of sustainability, providing not only superior sports performance, but stewardship of the environment and care for individual health.



Good Materials

- Made from natural materials



Resource Stewardship

- FSC® Chain of Custody Certification
- Selective harvesting
- Timber replacement program



People-Friendly Spaces

- Low VOC finishes and paints



Reuse and Recycle

- Maple can be repurposed



Tarkett Sports is a division of the Tarkett Group, which was established in 1886. The Tarkett Group has now reached over \$2.5 billion in annual sales and is a global leader in commercial, residential, and sports flooring. Tarkett Sports surfacing solutions include hardwood and synthetic basketball courts, volleyball courts, multipurpose gymnasium floors, weight room flooring, running tracks, and its world-renowned FieldTurf artificial turf.

For more information on ClutchCourt, including technical data and specifications, visit www.tarkettsportsindoor.com or call 888-364-6541.

The USGBC Membership logo is a trademark owned by the U.S. Green Building Council and is used with permission.



02/05/16



SURVIVOR®
SPORTFLOOR

ROLLS • TILES



Specifications

Item	Standard	Rating
Density	ASTM E96	68.3lbs/cubic feet
Tensile Strength	ASTM D412	2665 psi
Tear Resistance	ASTM D413	Average elongation at break 1.52
Hardness	D2240	Shore A 65 +/- 5
Slip Resistance	D C1028	Coefficient of Friction .084-.090
Abrasion	D4060	2,000 cycles taber abraser 1kg, 0.329g - 0.35g loss
Flammability	ASTM E648	Critical Radiant Flux <0.10W/cm ²
Chemicals	N/A	Resistant to most acids and chlorine
Volatile Organic Compounds	CDPH v1.2	<.05mg/m ³

Survivor products contribute up to 5 POINTS in two LEED categories

- MR - Building Product Disclosure and Optimization: Environmental Product Declarations (Option 1)
- MR - Building Product Disclosure and Optimization: Environmental Production Declarations (Option 2)
- MR - Building Product Disclosure and Optimization: Sourcing of Raw Materials
- MR - Building Product Disclosure and Optimization: Material Ingredients
- EQ - Low Emitting Materials



Our mission is to empower our committed employees, many seeking a second chance in their life and career, so they can responsibly increase demand for products manufactured with raw materials diverted from a waste stream, creating a second life for such materials and reducing the need for virgin materials, and by doing so, will improve the economic vitality and environmental sustainability of our community.



www.usrubber.com
info@usrubber.com
(833) US RUBBER (877-8223)



Isometrics

- Standard with 10% color fleck
- 19 color choices available



Blue 109



Brown 89



Beige 93



Chrome 110



Cream 98



Charcoal 114



Gold 88



Green 91

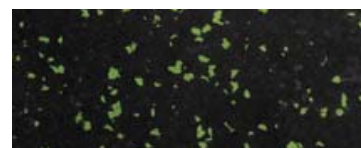

Forest 90

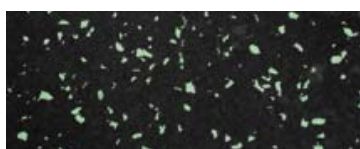

Light Green 108

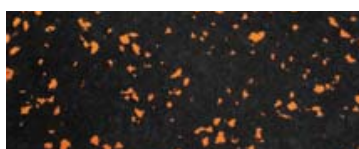

Orange 104



Grey 82

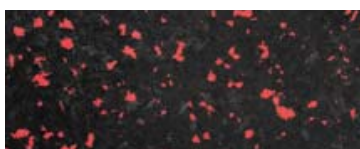

Red 96

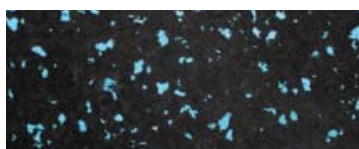

Spa 85



Purple 92

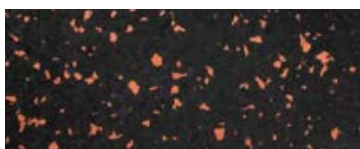

Terra 80



White 94

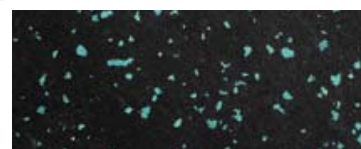

Teal 100

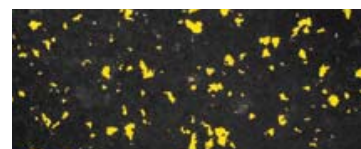

Yellow 83

Cross Training

- Standard with 20% color fleck
- 16 pre-designed color blends



Carnival
80, 88, 91, 93, 96, 109



Desert Storm
89, 93



Brick-n-Mortar
80, 94

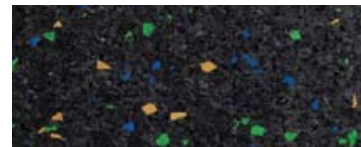

Electrolyte
88, 91, 109

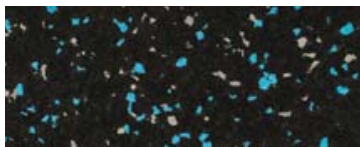

Extreme Serene
82, 85

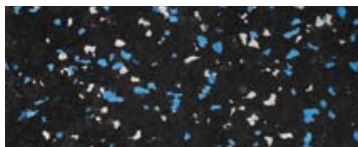

Glacier
82, 109



In the Zone
96, 110



Margarita
91, 94

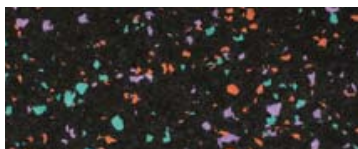

Miami Muscle
80, 92, 100



Nerves of Steel
82, 110



Patriot
96, 109, 110

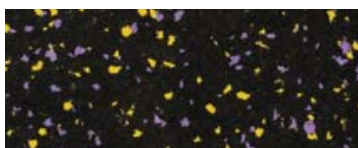

Planet Hollywood
83, 92



Sea-n-Sand
94, 109

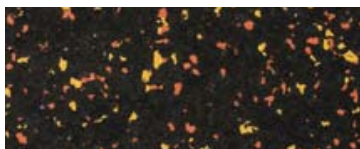

Trailblazer
80, 88



Trophy
93, 94



Vision Quest
80, 83



- Standard with 85% color fleck
- 2-4 color fleck blends



Bronco
82, 104, 109

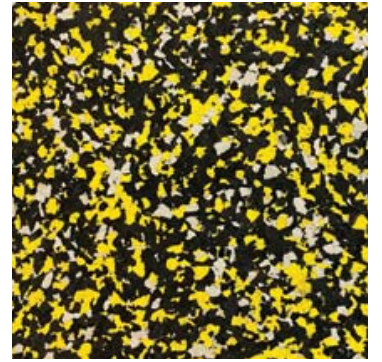

Bumblebee
82, 83



Celebration
82, 83, 96, 109

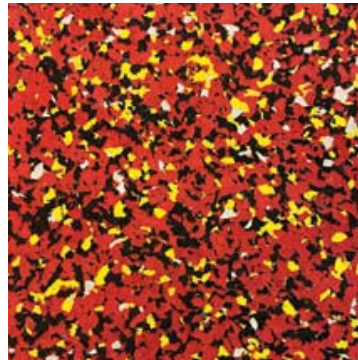

Del Sol
83, 96, 110

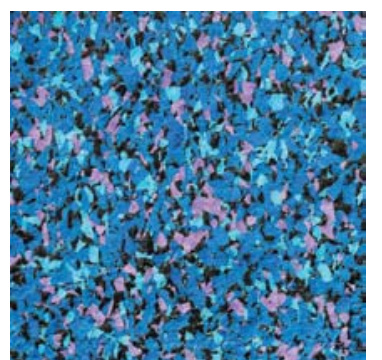

High Dive
85, 92, 109

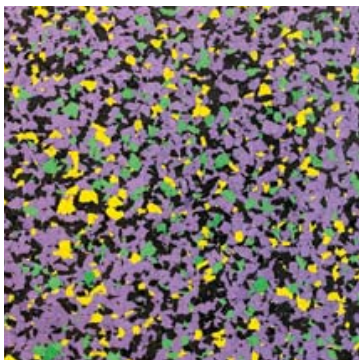

Mardi Gras
83, 91, 92



Smash
90, 91



Surf's Up
93, 94, 98, 109



- Standard with 20% color fleck
- Combines BigChip™ with regular fleck



Avalanche
82, 82-BC, 110, 110-BC

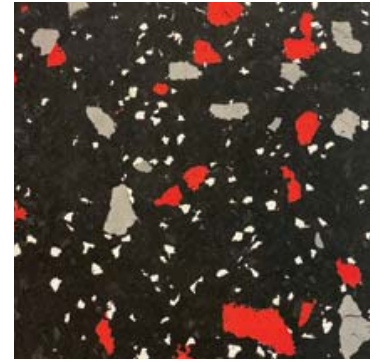

Buckeye
82-BC, 96-BC, 110

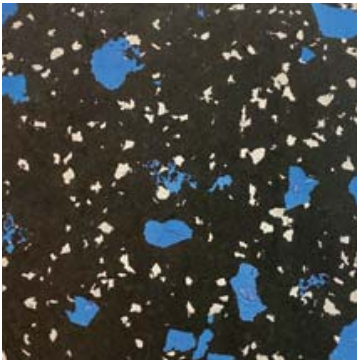

Iceberg
82, 109-BC

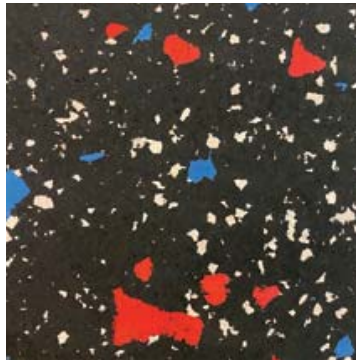

Merica
94, 96-BC, 109-BC

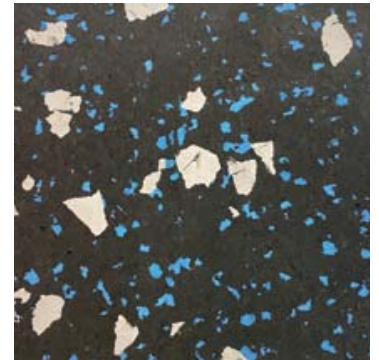

Polar
82-BC, 109

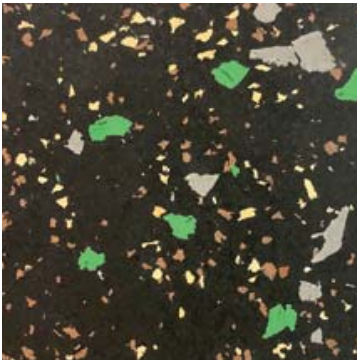

Rambo
82-BC, 88, 89, 91-BC

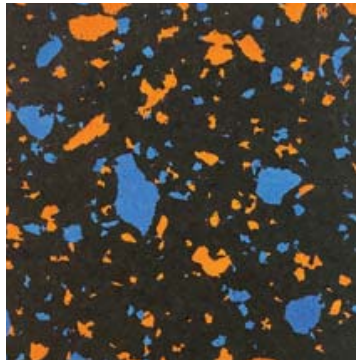

Stallion
104, 104-BC, 109, 109-BC

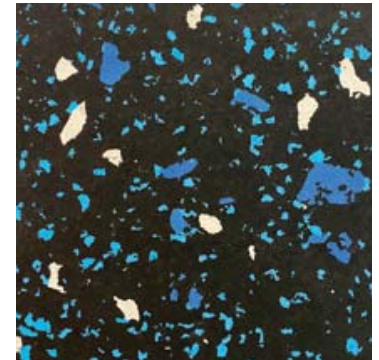

Tighten Up
85, 109-BC, 110-BC



- Standard with 20% color fleck
- 2-3 times larger than regular fleck

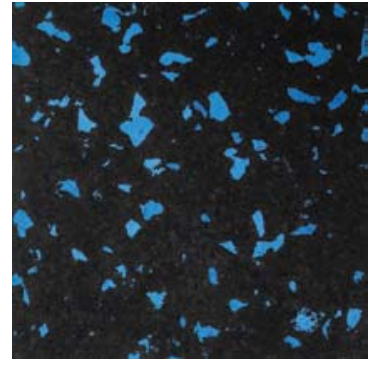

Blue 109-BC

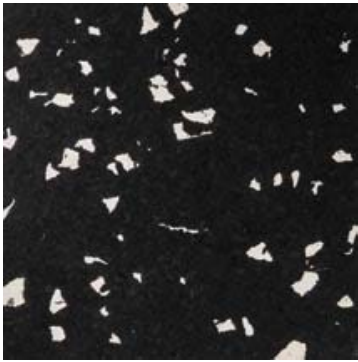

Chrome 110-BC

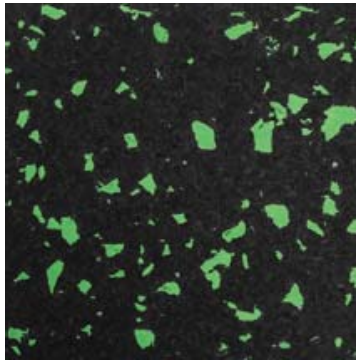

Green 91-BC



Grey 82-BC

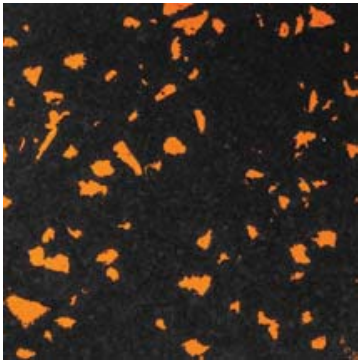

Orange 104-BC

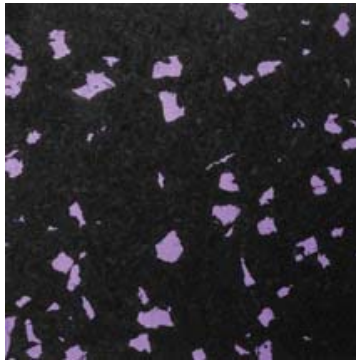

Purple 92-BC

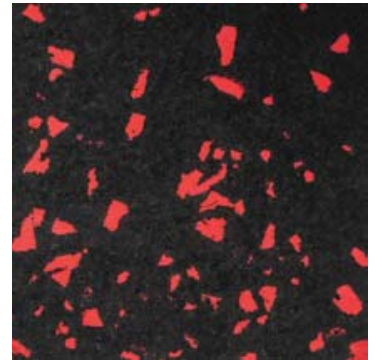

Red 96-BC

Color Options



Beige 93



Blue 109



Brown 89



Charcoal 114



Chrome 110



Cream 98



Forest 90



Gold 88



Green 91



Grey 82



Lt Green 108



Orange 104



Purple 92



Red 96



Spa 85

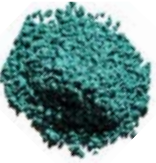

Teal 100



Terra 80



White 94



Yellow 83

Color Gradient

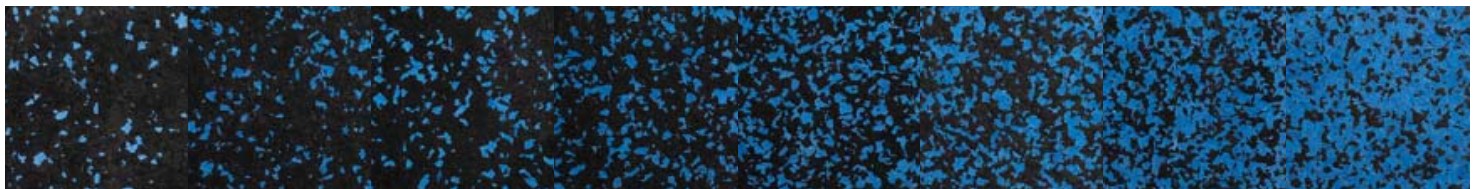

10%

20%

30%

40%

50%

60%

70%

85%

25 Year Limited Warranty

U.S. Rubber Recycling warrants to the first purchaser for use that its merchandise is free of defects in material and workmanship for a period of twenty five (25) years from the date of invoice, provided that such merchandise is listed in U.S. Rubber Recycling's current price list at the time of the claim and such defects are not the result of ordinary wear and tear or an Act of God. U.S. Rubber Recycling's obligation under this warranty is limited to repair or replacement, at its option, and such repair or replacement shall be the only remedy. U.S. Rubber Recycling is not responsible for damage due to transportation, improper handling, alteration, abuse or negligence. U.S. Rubber Recycling shall not be

liable for any incidental or consequential damages including, but not limited to, any expenses associated with the removal or installation of any defective merchandise covered by this warranty. With respect to flooring and underlayment, U.S. Rubber Recycling's warranty is null and void if product is (i) stored for more than forty five (45) days or (ii) stored or installed in an environment where temperature and humidity are not controlled 24|7|365. U.S. Rubber Recycling makes no implied warranty of merchantability or fitness for any particular purpose. ALL OTHER WARRANTIES, EXPRESS OR IMPLIED, ARE EXCLUDED.

Roll Dimensions

Thickness Chart

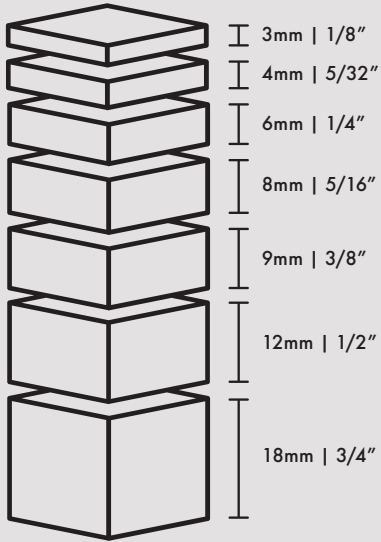

Thicknesses	Lengths*
3mm 1/8"	75'
4mm 5/32"	75'
6mm 1/4"	75'
8mm 5/16"	50'
9mm 3/8"	50'
12mm 1/2"	50'
18mm 3/4"	15'

*Custom Lengths are always available



Tile Dimensions

Thickness Chart

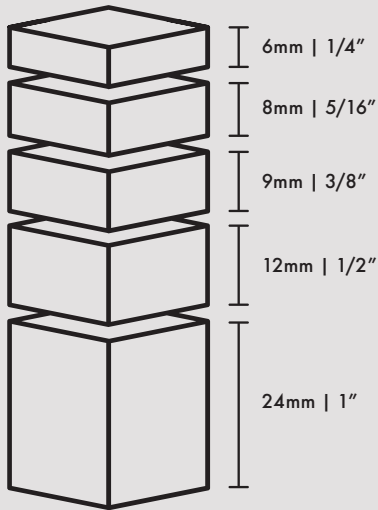

Thicknesses

Interlocking & Square Tile

- 6mm | 1/4"
- 8mm | 5/16"
- 9mm | 3/8"
- 12mm | 1/2"

Eco-Lock Tile

- 6mm | 1/4"
- 8mm | 5/16"

MEGA Tile

- 24mm | 1"

Sizes/Styles

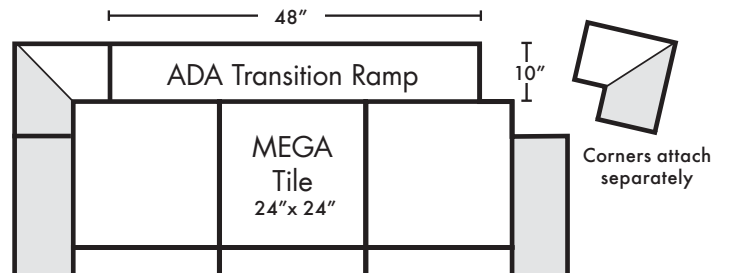
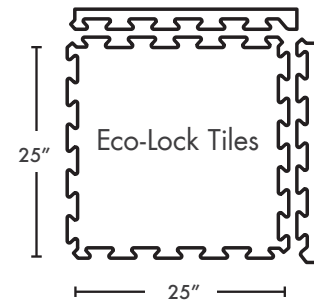
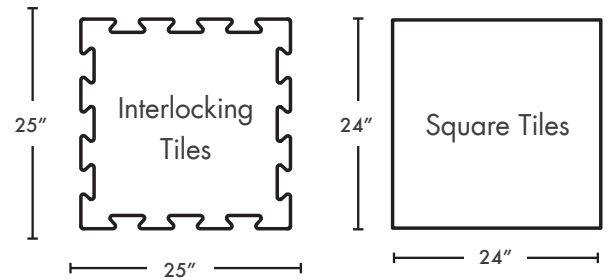

Interlocking Tile

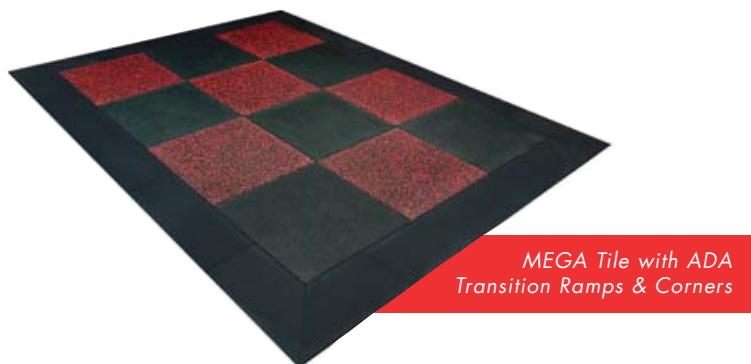

Eco-Lock Tile

Contact info@usrubber.com for assistance specifying MEGA Tile



U.S. Rubber
RECYCLING, INC.

SURVIVOR[®]
SPORT FLOOR

9
RESILIENT
FLOORING